



**VILLAGE OF VILLA PARK**

**CONTRACT DOCUMENTS**

**FOR THE**

**CHARLES AVENUE IMPROVEMENT PROJECT**

**JUNE 18, 2021**

**PREPARED BY**

**STRAND ASSOCIATES, INC.**



**ADVERTISEMENT FOR BIDS  
VILLAGE OF VILLA PARK  
FRIDAY, JUNE 18, 2021**

**PROJECT: CHARLES AVENUE IMPROVEMENT PROJECT**

This project consists of improvements on Charles Avenue from Saint Charles Road to Oak Street in Villa Park, DuPage County, Illinois. Charles Avenue will be reconstructed with hot-mix asphalt pavement and Portland cement concrete curb and gutter. Existing sidewalks will be removed and replaced where indicated in the field. The existing combined sewer will be converted to a sanitary sewer. Existing sanitary sewer service and taps will be replaced in select locations. The existing sanitary sewer and services will be cleaned, rehabilitated, and lined. A new 8" water main will be installed and all water services and curb stops in boxes will be replaced. The existing water system will be removed and/or abandoned. New storm sewer will be constructed with associated structures.

**BID DEADLINE: TUESDAY, JULY 6, 2021, 11:00 AM LOCAL TIME**

The Village reserves the right to extend the Bid Deadline from this date and time to accept Bids submitted after the Bid Deadline, as the Village, in its sole discretion, determines is in the best interest of the Village.

**NOTICE:** Proposals for the **CHARLES AVENUE IMPROVEMENT PROJECT** will be received electronically by the Village of Villa Park, Illinois, through QuestCDN at <https://www.questcdn.com> under **QuestCDN Project #7068504** until the Bid Deadline. Immediately thereafter, the proposals will be opened and read aloud via Zoom. Notwithstanding the foregoing, the Village reserves the right to defer, postpone, delay, or reschedule the Bid Opening for such time and to such date as the Village, in its sole discretion, determines is in the best interest of the Village. The Bid Opening Zoom meeting may be accessed as follows:

<https://us06web.zoom.us/j/87570515834?pwd=UXpkcG02RWt0ZTY3a1prYWwHeGdmdz09>

Meeting ID: 875 7051 5834  
Passcode: 102359

Proposals shall be submitted in accordance with the Bidding Documents prepared by Strand Associates, Inc., 1170 South Houbolt Road, Joliet, Illinois 60431.

**BIDDER QUALIFICATIONS:** Bidders, in submitting a Bid, shall comply with all applicable Federal, State and Local laws and requirements; shall provide documentation of that compliance in accordance with the requirements of the Contract Documents or as requested by the Village; and, in submitting a Bid, Bidders affirm that they are qualified under all applicable laws and requirements to do so, and agree to be bound by the determination of the Village as to Bidder's compliance and qualifications.

County DuPage  
Local Public Agency Village of Villa Park  
Project Charles Ave  
Route N Charles Ave (St Charles to Oak)

1. THIS AGREEMENT, made and concluded the 23<sup>rd</sup> day of July, 2021  
Month and Year

between the Village of Villa Park  
acting by and through its Board of Trustees known as the party of the first part, and  
A Lamp Concrete Contractors, Inc. his/their executors, administrators, successors or assigns,  
known as the party of the second part.

2. Witnesseth: That for and in consideration of the payments and agreements mentioned in the Proposal hereto attached, to be made and performed by the party of the first part, and according to the terms expressed in the Bond referring to these presents, the party of the second part agrees with said party of the first part at his/their own proper cost and expense to do all the work, furnish all materials and all labor necessary to complete the work in accordance with the plans and specifications hereinafter described, and in full compliance with all of the terms of this agreement and the requirements of the Engineer under it.

3. And it is also understood and agreed that the LPA Formal Contract Proposal, Special Provisions, Affidavit of Illinois Business Office, Apprenticeship or Training Program Certification, and Contract Bond hereto attached, and the Plans for the Charles Avenue Improvement Project (St Charles to Oak), in the Village of Villa Park, approved by the Village of Villa Park on July 12, 2021, are essential documents of this contract and are a part hereof.

4. IN WITNESS WHEREOF, The said parties have executed these presents on the date above mentioned.

Attest: [Signature]  
Village Clerk

The Village of Villa Park  
By [Signature]  
President Party of the First Part

(Seal)



(If a Corporation)

Corporate Name A Lamp Concrete Contractors, Inc.  
By [Signature]  
President Party of the Second Part

(If a Co-Partnership)

Attest:



Partners doing Business under the firm name of

Party of the Second Part

(If an individual)

Party of the Second Part







IN TESTIMONY WHEREOF, the said PRINCIPAL and the said SURETY have caused this instrument to be signed by their respective officers this 15th day of July A.D. 2021

**PRINCIPAL**

A. Lamp Concrete Contractors, Inc.  
(Company Name)

By: Adele Lampignano  
(Signature & Title)

Attest: [Signature]  
(Signature & Title)

\_\_\_\_\_  
(Company Name)

By: \_\_\_\_\_  
(Signature & Title)

Attest: \_\_\_\_\_  
(Signature & Title)

(If PRINCIPAL is a joint venture of two or more contractors, the company names and authorized signature of each contractor must be affixed.)

STATE OF ILLINOIS,

COUNTY OF Cook

I, Kelly L. Biello, a Notary Public in and for said county, do hereby certify that

Adele Lampignano  
Tracy Lampignano  
(Insert names of individuals signing on behalf of PRINCIPAL)

who are each personally known to me to be the same persons whose names are subscribed to the foregoing instrument on behalf of PRINCIPAL, appeared before me this day in person and acknowledged respectively, that they signed and delivered said instrument as their free and voluntary act for the uses and purposes therein set forth.

Given under my hand and notarial seal this 15th day of July

My commission expires 11/16/2024 Kelly L. Biello  
Notary Public

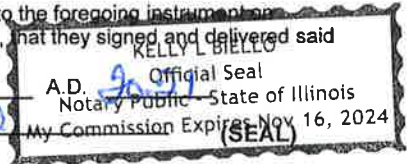

**SURETY**

The Hanover Insurance Company  
(Name of Surety)

By: [Signature]  
(Signature of Attorney-in-Fact)

**Todd Schaap (SEAL)**

STATE OF WISCONSIN,

COUNTY OF Kenosha

I, Megan Otto, a Notary Public in and for said county, do hereby certify that

**Todd Schaap**

(Insert names of individuals signing on behalf of SURETY)

who are each personally known to me to be the same persons whose names are subscribed to the foregoing instrument on behalf of SURETY, appeared before me this day in person and acknowledged respectively, that they signed and delivered said instrument as their free and voluntary act for the uses and purposes therein set forth.

Given under my hand and notarial seal this 15th day of July A.D. 2021

My commission expires 3/3/2024 Megan Otto  
Notary Public

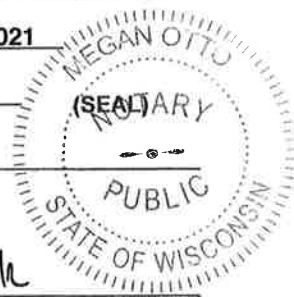

Approved this 23rd day of July, A.D. 2021

Attest: [Signature]  
Village Clerk

Village of Villa Park  
(Awarding Authority)  
[Signature]  
(Chairman/Mayor/President)



THE HANOVER INSURANCE COMPANY  
MASSACHUSETTS BAY INSURANCE COMPANY  
CITIZENS INSURANCE COMPANY OF AMERICA

POWER OF ATTORNEY

THIS Power of Attorney limits the acts of those named herein, and they have no authority to bind the Company except in the manner and to the extent herein stated.

KNOW ALL PERSONS BY THESE PRESENTS:

That THE HANOVER INSURANCE COMPANY and MASSACHUSETTS BAY INSURANCE COMPANY, both being corporations organized and existing under the laws of the State of New Hampshire, and CITIZENS INSURANCE COMPANY OF AMERICA, a corporation organized and existing under the laws of the State of Michigan, (hereinafter individually and collectively the "Company") does hereby constitute and appoint,

Thomas O. Chambers, Todd Schaap, Daniel Gibson, Eric Olson, Kimberly S. Rasch, Jackle Sheldon and/or Josie Benson

Of Shorewest Surety Services, Inc. of Racine, WI each individually, if there be more than one named, as its true and lawful attorney(s)-in-fact to sign, execute, seal, acknowledge and deliver for, and on its behalf, and as its act and deed any place within the United States, any and all surety bonds, recognizances, undertakings, or other surety obligations. The execution of such surety bonds, recognizances, undertakings or surety obligations, in pursuance of these presents, shall be as binding upon the Company as if they had been duly signed by the president and attested by the secretary of the Company, in their own proper persons. Provided however, that this power of attorney limits the acts of those named herein; and they have no authority to bind the Company except in the manner stated and to the extent of any limitation stated below:

Any such obligations in the United States, not to exceed Forty Million and No/100 (\$40,000,000) in any single instance

That this power is made and executed pursuant to the authority of the following Resolutions passed by the Board of Directors of said Company, and said Resolutions remain in full force and effect:

RESOLVED: That the President or any Vice President, in conjunction with any Vice President, be and they hereby are authorized and empowered to appoint Attorneys-in-fact of the Company, in its name and as it acts, to execute and acknowledge for and on its behalf as surety, any and all bonds, recognizances, contracts of indemnity, waivers of citation and all other writings obligatory in the nature thereof, with power to attach thereto the seal of the Company. Any such writings so executed by such Attorneys-in-fact shall be binding upon the Company as if they had been duly executed and acknowledged by the regularly elected officers of the Company in their own proper persons.

RESOLVED: That any and all Powers of Attorney and Certified Copies of such Powers of Attorney and certification in respect thereto, granted and executed by the President or Vice President in conjunction with any Vice President of the Company, shall be binding on the Company to the same extent as if all signatures therein were manually affixed, even though one or more of any such signatures thereon may be facsimile. (Adopted October 7, 1981 – The Hanover Insurance Company; Adopted April 14, 1982 – Massachusetts Bay Insurance Company; Adopted September 7, 2001 – Citizens Insurance Company of America)

IN WITNESS WHEREOF, THE HANOVER INSURANCE COMPANY, MASSACHUSETTS BAY INSURANCE COMPANY and CITIZENS INSURANCE COMPANY OF AMERICA have caused these presents to be sealed with their respective corporate seals, duly attested by two Vice Presidents, this 15th day of March, 2017.

The Hanover Insurance Company  
Massachusetts Bay Insurance Company  
Citizens Insurance Company of America

John C. Roche, EVP and President



The Hanover Insurance Company  
Massachusetts Bay Insurance Company  
Citizens Insurance Company of America

James H. Kawiecki, Vice President

THE COMMONWEALTH OF MASSACHUSETTS )  
COUNTY OF WORCESTER ) ss.

On this 15th day of March, 2017 before me came the above named Vice Presidents of The Hanover Insurance Company, Massachusetts Bay Insurance Company and Citizens Insurance Company of America, to me personally known to be the individuals and officers described herein, and acknowledged that the seals affixed to the preceding instrument are the corporate seals of The Hanover Insurance Company, Massachusetts Bay Insurance Company and Citizens Insurance Company of America, respectively, and that the said corporate seals and their signatures as officers were duly affixed and subscribed to said instrument by the authority and direction of said Corporations.

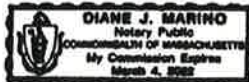

Diane J. Marino, Notary Public  
My Commission Expires March 4, 2022

I, the undersigned Vice President of The Hanover Insurance Company, Massachusetts Bay Insurance Company and Citizens Insurance Company of America, hereby certify that the above and foregoing is a full, true and correct copy of the Original Power of Attorney issued by said Companies, and do hereby further certify that the said Powers of Attorney are still in force and effect.

GIVEN under my hand and the seals of said Companies, at Worcester, Massachusetts, this 15th day of July 2021

CERTIFIED COPY

Theodore G. Martinez, Vice President





# CERTIFICATE OF LIABILITY INSURANCE

DATE (MM/DD/YYYY)  
7/16/2021

**THIS CERTIFICATE IS ISSUED AS A MATTER OF INFORMATION ONLY AND CONFERS NO RIGHTS UPON THE CERTIFICATE HOLDER. THIS CERTIFICATE DOES NOT AFFIRMATIVELY OR NEGATIVELY AMEND, EXTEND OR ALTER THE COVERAGE AFFORDED BY THE POLICIES BELOW. THIS CERTIFICATE OF INSURANCE DOES NOT CONSTITUTE A CONTRACT BETWEEN THE ISSUING INSURER(S), AUTHORIZED REPRESENTATIVE OR PRODUCER, AND THE CERTIFICATE HOLDER.**

**IMPORTANT: If the certificate holder is an ADDITIONAL INSURED, the policy(ies) must be endorsed. If SUBROGATION IS WAIVED, subject to the terms and conditions of the policy, certain policies may require an endorsement. A statement on this certificate does not confer rights to the certificate holder in lieu of such endorsement(s).**

<b>PRODUCER</b> ERIC MILLER (19911) 28369 DAVIS PKWY STE 405 WARRENVILLE, IL 60555-0000	<b>CONTACT NAME:</b> ERIC MILLER <b>PHONE (A/C, No, Ext):</b> 630-836-0845 <b>FAX (A/C, No):</b> 630-836-0995 <b>E-MAIL ADDRESS:</b> ERIC.MILLER@COUNTRYFINANCIAL.COM																					
<b>INSURED</b> 2971527 A LAMP CONCRETE CONTRACTORS INC 1900 WRIGHT BLVD SCHAUMBURG, IL 60193	<table border="1" style="width: 100%; border-collapse: collapse;"> <tr> <th colspan="2" style="text-align: center;">INSURER(S) AFFORDING COVERAGE</th> <th style="text-align: center;">NAIC #</th> </tr> <tr> <td style="width: 80%;">INSURER A : COUNTRY Mutual Insurance Company</td> <td></td> <td style="text-align: center;">20990</td> </tr> <tr> <td>INSURER B :</td> <td></td> <td></td> </tr> <tr> <td>INSURER C :</td> <td></td> <td></td> </tr> <tr> <td>INSURER D :</td> <td></td> <td></td> </tr> <tr> <td>INSURER E :</td> <td></td> <td></td> </tr> <tr> <td>INSURER F :</td> <td></td> <td></td> </tr> </table>	INSURER(S) AFFORDING COVERAGE		NAIC #	INSURER A : COUNTRY Mutual Insurance Company		20990	INSURER B :			INSURER C :			INSURER D :			INSURER E :			INSURER F :		
INSURER(S) AFFORDING COVERAGE		NAIC #																				
INSURER A : COUNTRY Mutual Insurance Company		20990																				
INSURER B :																						
INSURER C :																						
INSURER D :																						
INSURER E :																						
INSURER F :																						

**COVERAGES      CERTIFICATE NUMBER:      REVISION NUMBER:**

THIS IS TO CERTIFY THAT THE POLICIES OF INSURANCE LISTED BELOW HAVE BEEN ISSUED TO THE INSURED NAMED ABOVE FOR THE POLICY PERIOD INDICATED. NOTWITHSTANDING ANY REQUIREMENT, TERM OR CONDITION OF ANY CONTRACT OR OTHER DOCUMENT WITH RESPECT TO WHICH THIS CERTIFICATE MAY BE ISSUED OR MAY PERTAIN, THE INSURANCE AFFORDED BY THE POLICIES DESCRIBED HEREIN IS SUBJECT TO ALL THE TERMS, EXCLUSIONS AND CONDITIONS OF SUCH POLICIES. LIMITS SHOWN MAY HAVE BEEN REDUCED BY PAID CLAIMS.

INSR LTR	TYPE OF INSURANCE	ADDL INSR	SUBR WVD	POLICY NUMBER	POLICY EFF (MM/DD/YYYY)	POLICY EXP (MM/DD/YYYY)	LIMITS
A	GENERAL LIABILITY <input checked="" type="checkbox"/> COMMERCIAL GENERAL LIABILITY <input type="checkbox"/> CLAIMS-MADE <input checked="" type="checkbox"/> OCCUR <hr/> GEN'L AGGREGATE LIMIT APPLIES PER: <input type="checkbox"/> POLICY <input checked="" type="checkbox"/> PRO-JECT <input type="checkbox"/> LOC	✓	✓	AB9277522	2/20/2021	2/20/2022	EACH OCCURRENCE \$ 1,000,000 DAMAGE TO RENTED PREMISES (Ea occurrence) \$ 100,000 MED EXP (Any one person) \$ 5,000 PERSONAL & ADV INJURY \$ 1,000,000 GENERAL AGGREGATE \$ 2,000,000 PRODUCTS - COMP/OP AGG \$ 2,000,000 \$
A	AUTOMOBILE LIABILITY <input type="checkbox"/> ANY AUTO <input type="checkbox"/> ALL OWNED AUTOS <input checked="" type="checkbox"/> SCHEDULED AUTOS <input checked="" type="checkbox"/> HIRED AUTOS <input checked="" type="checkbox"/> NON-OWNED AUTOS	✓		AV9277517	2/20/2021	2/20/2022	COMBINED SINGLE LIMIT (Ea accident) \$ 1,000,000 BODILY INJURY (Per person) \$ BODILY INJURY (Per accident) \$ PROPERTY DAMAGE (Per accident) \$ \$
	UMBRELLA LIAB <input type="checkbox"/> OCCUR EXCESS LIAB <input type="checkbox"/> CLAIMS-MADE DED    RETENTION \$						EACH OCCURRENCE \$ AGGREGATE \$ \$
A	WORKERS COMPENSATION AND EMPLOYERS' LIABILITY ANY PROPRIETOR/PARTNER/EXECUTIVE OFFICER/MEMBER EXCLUDED? (Mandatory in NH) If yes, describe under DESCRIPTION OF OPERATIONS below	Y/N Y	N/A	AW9277515	2/20/2021	2/20/2022	<input checked="" type="checkbox"/> WC STATUTORY LIMITS <input type="checkbox"/> OTHER E.L. EACH ACCIDENT \$ 1,000,000 E.L. DISEASE - EA EMPLOYEE \$ 1,000,000 E.L. DISEASE - POLICY LIMIT \$ 1,000,000

**DESCRIPTION OF OPERATIONS / LOCATIONS / VEHICLES (Attach ACORD 101, Additional Remarks Schedule, if more space is required)**  
 JOB NAME:  
 IT JOB #21038 VILLA PARK - CHARLES AVE IMPROVEMENTS  
 (CONTINUED)

<b>CERTIFICATE HOLDER</b>  VILLAGE OF VILLA PARK 20 S ARDMORE VILLA PARK, IL 60181	<b>CANCELLATION</b>  SHOULD ANY OF THE ABOVE DESCRIBED POLICIES BE CANCELLED BEFORE THE EXPIRATION DATE THEREOF, NOTICE WILL BE DELIVERED IN ACCORDANCE WITH THE POLICY PROVISIONS.  AUTHORIZED REPRESENTATIVE 
--	--



AGENCY CUSTOMER ID: \_\_\_\_\_

LOC #: \_\_\_\_\_



## ADDITIONAL REMARKS SCHEDULE

Page 1 of 1

AGENCY		NAMED INSURED	
POLICY NUMBER AB9277522		A LAMP CONCRETE CONTRACTORS INC 1900 WRIGHT BLVD SCHAUMBURG, IL 60193	
CARRIER COUNTRY Mutual Insurance Company	NAIC CODE 20990	EFFECTIVE DATE: 7/16/2021	

### ADDITIONAL REMARKS

**THIS ADDITIONAL REMARKS FORM IS A SCHEDULE TO ACORD FORM,**  
**FORM NUMBER:** ACORD 25 **FORM TITLE:** CERTIFICATE OF LIABILITY INSURANCE

**REMARKS:**

THE COVERAGE AND LIMITS CONFORM TO THE MINIMUM REQUIRED BY ARTICLE 107.27 OF THE STANDARD SPECIFICATIONS FOR ROAD AND BRIDGE CONSTRUCTION

**WAIVERS:**

SUBROGATION RIGHTS DIRECTLY AGAINST THE CERTIFICATE HOLDER ARE WAIVED WITH REGARD TO WORKERS COMPENSATION. THE INSURING COMPANY WAIVES ITS RIGHTS OF SUBROGATION (RIGHTS TO RECOVER) AGAINST THE CERTIFICATE HOLDER NAMED BELOW WITH RESPECT TO ANY PAYMENTS MADE FOR LIABILITY COVERAGE(S) UNDER THE POLICY(IES) SHOWN IN THE GENERAL LIABILITY SECTION OF THIS CERTIFICATE. THE INSURANCE AFFORDED BY THIS POLICY FOR THE ADDITIONAL INSURED(S) IS PRIMARY INSURANCE AND ANY OTHER INSURANCE MAINTAINED BY OR AVAILABLE TO THE ADDITIONAL INSURED(S) IS NON-CONTRIBUTORY.

**ADDITIONAL INSURED(S):**

VILLAGE OF VILLA PARK, STRAND ASSOCIATES, INC., SANDRA HECHLER AND SARAD LAKHANI

**WORKERS COMPENSATION EXCLUSIONS:**

PROPRIETOR, PARTNER(S), EXECUTIVE OFFICER(S), MEMBERS(S) IS/ARE EXCLUDED ON WORKERS COMPENSATION BY ENDORSEMENT.



**THIS ENDORSEMENT CHANGES THE POLICY. PLEASE READ IT CAREFULLY.**

**NOTICE OF CANCELLATION TO CERTIFICATE HOLDER(S)**

This endorsement modifies insurance provided under the following:

**BUSINESSOWNERS COVERAGE PART  
COMMERCIAL AUTO COVERAGE PART  
COMMERCIAL GENERAL LIABILITY COVERAGE PART  
COMMERCIAL INLAND MARINE COVERAGE PART  
COMMERCIAL PROPERTY COVERAGE PART  
OWNERS AND CONTRACTORS PROTECTIVE LIABILITY COVERAGE PART  
PRODUCTS/COMPLETED OPERATIONS LIABILITY COVERAGE PART  
RAILROAD PROTECTIVE LIABILITY COVERAGE PART  
COMMERCIAL LIABILITY UMBRELLA COVERAGE PART  
WORKERS COMPENSATION AND EMPLOYERS LIABILITY INSURANCE POLICY**

With respect to coverage provided by this endorsement, the provisions of the Coverage Part (Policy) apply unless modified by the endorsement.

**Cancellation**

The following is added under the Cancellation Condition applicable to the Coverage Parts (Policy) listed above:

If we cancel this policy for any reason other than non payment of premium, we will mail written notice of cancellation to the certificate holder(s) on file with the Company. Notice will be provided prior to the effective date of cancellation. We will give the number of days notice as provided for in the Cancellation Condition of this policy. The notice will state the effective date of cancellation. The policy period will end on that date.

If you cancel this policy, or if we cancel for non payment of premium, we will mail written notice of such cancellation to the certificate holder(s) on file with the Company. The notice will state the date the policy was cancelled.

The notice will be mailed by first-class mail to the last known mailing address of the certificate holder(s) on file with the Company.

Any notice of cancellation provided by this endorsement applies only to the certificate holder(s) with a certificate of insurance applicable to this policy's period.

Our failure to send notice of cancellation to the certificate holder(s) will not amend, extend or alter the terms and conditions of this policy, including the cancellation of this policy.

If there is a conflict between any other policy cancellation provisions pertaining to the certificate holder(s) and this endorsement, the other policy provisions shall control.

Nothing contained here varies, alters, or extends any provisions of the policy except as provided in this endorsement.

**Includes copyrighted material of Insurance Services Office, Inc., with its permission.**

**Includes copyrighted material of American Association of Insurance Services, Inc., with its permission.**

**Contains copyrighted material of the National Council on Compensation Insurance, with its permission.**



THIS ENDORSEMENT CHANGES THE POLICY. PLEASE READ IT CAREFULLY.

## PRIMARY AND NONCONTRIBUTORY – OTHER INSURANCE CONDITION

This endorsement modifies insurance provided under the following:

COMMERCIAL GENERAL LIABILITY COVERAGE PART  
PRODUCTS/COMPLETED OPERATIONS LIABILITY COVERAGE PART

The following is added to the **Other Insurance** Condition and supersedes any provision to the contrary:

### **Primary And Noncontributory Insurance**

This insurance is primary to and will not seek contribution from any other insurance available to an additional insured under your policy provided that:

(1) The additional insured is a Named Insured under such other insurance; and

(2) You have agreed in writing in a contract or agreement that this insurance would be primary and would not seek contribution from any other insurance available to the additional insured.



**THIS ENDORSEMENT CHANGES THE POLICY. PLEASE READ IT CAREFULLY.**

**ADDITIONAL INSURED – OWNERS, LESSEES OR CONTRACTORS – SCHEDULED PERSON OR ORGANIZATION**

This endorsement modifies insurance provided under the following:

COMMERCIAL GENERAL LIABILITY COVERAGE PART

**SCHEDULE**

Name Of Additional Insured Person(s) Or Organization(s)	Location(s) Of Covered Operations
VILLAGE OF VILLA PARK, STRAND ASSOCIATES, INC., SANDRA HECHLER AND SARAD LAKHANI	IT JOB #21038 VILLA PARK - CHARLES AVE IMPROVEMENTS
Information required to complete this Schedule, if not shown above, will be shown in the Declarations.	

**A. Section II – Who Is An Insured** is amended to include as an additional insured the person(s) or organization(s) shown in the Schedule, but only with respect to liability for "bodily injury", "property damage" or "personal and advertising injury" caused, in whole or in part, by:

1. Your acts or omissions; or
2. The acts or omissions of those acting on your behalf;

in the performance of your ongoing operations for the additional insured(s) at the location(s) designated above.

However:

1. The insurance afforded to such additional insured only applies to the extent permitted by law; and
2. If coverage provided to the additional insured is required by a contract or agreement, the insurance afforded to such additional insured will not be broader than that which you are required by the contract or agreement to provide for such additional insured.

**B.** With respect to the insurance afforded to these additional insureds, the following additional exclusions apply:

This insurance does not apply to "bodily injury" or "property damage" occurring after:

1. All work, including materials, parts or equipment furnished in connection with such work, on the project (other than service, maintenance or repairs) to be performed by or on behalf of the additional insured(s) at the location of the covered operations has been completed; or
2. That portion of "your work" out of which the injury or damage arises has been put to its intended use by any person or organization other than another contractor or subcontractor engaged in performing operations for a principal as a part of the same project.



C. With respect to the insurance afforded to these additional insureds, the following is added to **Section III – Limits Of Insurance:**

If coverage provided to the additional insured is required by a contract or agreement, the most we will pay on behalf of the additional insured is the amount of insurance:

1. Required by the contract or agreement; or

2. Available under the applicable Limits of Insurance shown in the Declarations;  
whichever is less.

This endorsement shall not increase the applicable Limits of Insurance shown in the Declarations.



**THIS ENDORSEMENT CHANGES THE POLICY. PLEASE READ IT CAREFULLY.**

**ADDITIONAL INSURED – OWNERS, LESSEES OR CONTRACTORS – COMPLETED OPERATIONS**

This endorsement modifies insurance provided under the following:

COMMERCIAL GENERAL LIABILITY COVERAGE PART  
PRODUCTS/COMPLETED OPERATIONS LIABILITY COVERAGE PART

**SCHEDULE**

Name Of Additional Insured Person(s) Or Organization(s)	Location And Description Of Completed Operations
VILLAGE OF VILLA PARK, STRAND ASSOCIATES, INC., SANDRA HECHLER AND SARAD LAKHANI	IT JOB #21038 VILLA PARK - CHARLES AVE IMPROVEMENTS
Information required to complete this Schedule, if not shown above, will be shown in the Declarations.	

**A. Section II – Who Is An Insured** is amended to include as an additional insured the person(s) or organization(s) shown in the Schedule, but only with respect to liability for "bodily injury" or "property damage" caused, in whole or in part, by "your work" at the location designated and described in the Schedule of this endorsement performed for that additional insured and included in the "products-completed operations hazard".

However:

1. The insurance afforded to such additional insured only applies to the extent permitted by law; and
2. If coverage provided to the additional insured is required by a contract or agreement, the insurance afforded to such additional insured will not be broader than that which you are required by the contract or agreement to provide for such additional insured.

**B.** With respect to the insurance afforded to these additional insureds, the following is added to **Section III – Limits Of Insurance:**

If coverage provided to the additional insured is required by a contract or agreement, the most we will pay on behalf of the additional insured is the amount of insurance:

1. Required by the contract or agreement; or
  2. Available under the applicable Limits of Insurance shown in the Declarations;
- whichever is less.

This endorsement shall not increase the applicable Limits of Insurance shown in the Declarations.



## WAIVER OF TRANSFER OF RIGHTS OF RECOVERY AGAINST OTHERS TO US

This endorsement modifies insurance provided under the following:

COMMERCIAL GENERAL LIABILITY COVERAGE PART  
PRODUCTS/COMPLETED OPERATIONS LIABILITY COVERAGE PART

### SCHEDULE

**Name Of Person Or Organization:**

VILLAGE OF VILLA PARK, STRAND ASSOCIATES, INC., SANDRA HECHLER AND SARAD LAKHANI

Information required to complete this Schedule, if not shown above, will be shown in the Declarations.

The following is added to Paragraph 8. **Transfer Of Rights Of Recovery Against Others To Us of Section IV – Conditions:**

We waive any right of recovery we may have against the person or organization shown in the Schedule above because of payments we make for injury or damage arising out of your ongoing operations or "your work" done under a contract with that person or organization and included in the "products-completed operations hazard". This waiver applies only to the person or organization shown in the Schedule above.



**THIS ENDORSEMENT CHANGES THE POLICY. PLEASE READ IT CAREFULLY  
BLANKET WAIVER OF OUR RIGHT TO RECOVER FROM OTHERS**

This endorsement modifies insurance provided under the following:

**WORKERS COMPENSATION INSURANCE POLICY**

We have the right to recover our payments from anyone liable for an injury covered by this policy. We will not enforce our right to take direct action against the person or organization named in the Schedule below. This agreement applies only to the extent that you perform work for others who require you to obtain this agreement.

This agreement shall not operate to directly or indirectly benefit anyone not named in the Schedule. We maintain our right to assert a lien on any action taken by any person(s) against the person or organizations named in the Schedule.

**SCHEDULE**

Persons or organizations to whom a certificate of insurance has been issued and approved by us, and that certificate waives our rights of subrogation against the certificate holder under this policy and is in effect at the time of the occurrence.





**Illinois Department  
of Transportation**

**Local Public Agency  
Formal Contract**

PROPOSAL SUBMITTED BY		
<b>A Lamp Concrete Contractors, Inc.</b>		
Contractor's Name		
<b>1900 Wright Blvd</b>		
Street		P.O. Box
<b>Schaumburg,</b>	<b>IL</b>	<b>60193</b>
City	State	Zip Code

**STATE OF ILLINOIS**

COUNTY DuPage  
Village of Villa Park  
 (Name of City, Village, Town or Road District)

FOR THE IMPROVEMENT OF

PROJECT Charles Avenue Improvement Project (St Charles to Oak)  
 ROUTE N Charles Ave (St Charles to Oak)  
 TYPES OF FUNDS Local Funds

SPECIFICATIONS (required)

CONTRACT BOND (required)



**BID SECURITY:** Bid security in the amount of not less than ten percent (10%) of the Bid shall accompany each Bid in accordance with the Bidding Documents.

**CONTRACT SECURITY:** The Bidder to whom a Contract is awarded shall be required to furnish both a Performance Bond and a Payment Bond acceptable to the Village for one-hundred percent (100%) of the Contract Price, in accordance with the requirements of the Contract Documents.

**REQUESTS FOR INFORMATION OR CLARIFICATION:** All requests for information or clarification shall be submitted to the Village of Villa Park by email to [engineering@invillapark.com](mailto:engineering@invillapark.com). All responses that are provided to requests for information or clarification will be provided through QuestCDN at <https://www.questcdn.com> under **QuestCDN Project #7068504**.

The Village will accept requests for information or clarification submitted in accordance with the above requirements until **WEDNESDAY, JUNE 30, 2021, 12:00 PM LOCAL TIME**. Requests for information or clarification received after such time will not be accepted and will receive no response.

**ADDENDA:** The Village reserves the right to modify the Bidding Documents.

**RIGHTS RESERVED:** The Village will select the lowest, most responsible bidder. The Village reserves the right to reject any or all Bids, to waive any informalities or technicalities in bidding, and to accept the Bid which best serves the interests of the Village. The Village shall, in its sole discretion, determine what does or does not constitute an informality or technicality, and, in submitting a Bid, Bidder agrees to be bound by that determination.

The Village may make such investigations as it deems necessary to determine the ability of the Bidder to perform the Work, and the Bidder shall furnish to the Village all such information and data for this purpose as the Village may request. The Village reserves the right to reject any Bid if the evidence submitted by, or investigation of, such Bidder fails to satisfy the Village that such Bidder is properly qualified to carry out the obligations of the Agreement and to complete the Work contemplated therein.

**WAGE RATES:** All applicable laws, ordinances, and the rules and regulations of all authorities having jurisdiction over construction of the PROJECT shall apply to the contract throughout.

**BIDDING DOCUMENTS:** The Bidding Documents may be obtained from QuestCDN at <https://www.questcdn.com> under **QuestCDN Project #7068504** for a non-refundable fee of thirty dollars (\$30.00). An active QuestCDN account and login are required. Questions or issues regarding the QuestCDN platform shall be directed to QuestCDN by phone at 952-233-1632 or by email at [info@questcdn.com](mailto:info@questcdn.com). Hard copies of bidding documents will not be made available. An electronic "Not for Bid" version of the bidding documents in



RETURN WITH BID



Illinois Department of Transportation

Local Public Agency  
Formal Contract Proposal

PROPOSAL SUBMITTED BY		
A Lamp Concrete Contractors, Inc.		
Contractor's Name		
1900 Wright Boulevard		
Street	P.O. Box	
Schaumburg, IL 60193		
City	State	Zip Code

STATE OF ILLINOIS

COUNTY OF DuPage  
Village of Villa Park  
 (Name of City, Village, Town or Road District)

FOR THE IMPROVEMENT OF

STREET NAME OR ROUTE NO. Charles Avenue  
 SECTION NO. N/A  
 TYPES OF FUNDS Local

SPECIFICATIONS (required)

PLANS (required)

RETURN WITH BID

NOTICE TO BIDDERS

County DuPage  
 Local Public Agency Village of Villa Pa  
 Section Number N/A  
 Route Charles Avenue

Sealed proposals for the improvement described below will be received via Quest CDN,  
 \_\_\_\_\_ until 11:00 AM on July 6, 2021  
 \_\_\_\_\_ Time Date

Sealed proposals will be opened and read publicly Via Zoom Conference Meeting ID: 875 7051 5834  
 \_\_\_\_\_ at 11:00 AM on July 6, 2021  
 \_\_\_\_\_ Passcode 102359 Time Date

DESCRIPTION OF WORK

Name Charles Avenue Improvement Project  
 Location Charles Avenue from St. Charles Rd. to Oak Street, Villa Park, DuPage County, Illinois  
 Proposed Improvement Roadway reconstruction, storm sewer installation, combined sewer separation, sewer repairs sewer lining, water main and service installation, sidewalk repair, and parkway restoration.

1. Plans and proposal forms will be available for purchase and download via QuestCDN e-delivery  
 \_\_\_\_\_  
 \_\_\_\_\_ For information on bidding proposal contact Kevin Mantels, P.E., Assistant Village Engineer 630-834-8505

2.  Prequalification  
 If checked, the 2 low bidders must file within 24 hours after the letting an "Affidavit of Availability" (Form BC 57), in duplicate, showing all uncompleted contracts awarded to them and all low bids pending award for Federal, State, County, Municipal and private work. One original shall be filed with the Awarding Authority and one original with the IDOT District Office.

3. The Awarding Authority reserves the right to waive technicalities and to reject any or all proposals as provided in BLRS Special Provision for Bidding Requirements and Conditions for Contract Proposals.

4. The following BLR Forms shall be returned by the bidder to the Awarding Authority:
- a. BLR 12200: Local Public Agency Formal Contract Proposal
  - b. BLR 12200a Schedule of Prices
  - c. BLR 12230: Proposal Bid Bond (if applicable)
  - d. BLR 12325: Apprenticeship or Training Program Certification (do not use for federally funded projects)
  - e. BLR 12326: Affidavit of Illinois Business Office

5. The quantities appearing in the bid schedule are approximate and are prepared for the comparison of bids. Payment to the Contractor will be made only for the actual quantities of work performed and accepted or materials furnished according to the contract. The scheduled quantities of work to be done and materials to be furnished may be increased, decreased or omitted as hereinafter provided.

6. Submission of a bid shall be conclusive assurance and warranty the bidder has examined the plans and understands all requirements for the performance of work. The bidder will be responsible for all errors in the proposal resulting from failure or neglect to conduct an in depth examination. The Awarding Authority will, in no case be responsible for any costs, expenses, losses or changes in anticipated profits resulting from such failure or neglect of the bidder.

7. The bidder shall take no advantage of any error or omission in the proposal and advertised contract.

8. Permission will be given to a bidder to withdraw a proposal if the bidder makes the request in writing or in person before the time for opening proposals.



**SCHEDULE OF PRICES**

A bid will be declared unacceptable if neither a unit price nor total price is shown.  
 County DuPage Local Public Agency Village of Villa Park  
 Section N/A  
 Route Charles Avenue

**Schedule for Single Bid**  
 (For complete information covering these items, see plans and specifications)

Bidder's Proposal for making Entire					\$	1,637,041.99
Item No.	Items	Unit	Quantity	Unit Price	Total	
1	TREE STUMP REMOVAL (6 TO 15 UNITS DIAMETER)	EACH	15	\$ 25.00	\$ 375.00	
2	TREE STUMP REMOVAL (OVER 15 UNITS DIAMETER)	EACH	42	\$ 75.00	\$ 3,150.00	
3	TREE REMOVAL (6 TO 15 UNITS DIAMETER)	UNIT	75	\$ 25.00	\$ 1,875.00	
4	TREE REMOVAL (OVER 15 UNITS DIAMETER)	UNIT	225	\$ 38.00	\$ 8,550.00	
5	TREE PROTECTION	EACH	16	\$ 50.00	\$ 800.00	
6	TREE ROOT PRUNING	EACH	18	\$ 50.00	\$ 900.00	
7	TREE PRUNING (1 TO 10 INCH DIAMETER)	EACH	1	\$ 100.00	\$ 100.00	
8	TREE PRUNING (OVER 10 INCH DIAMETER)	EACH	17	\$ 125.00	\$ 2,125.00	
9	EXPLORATION TRENCH, SPECIAL	FOOT	317	\$ 1.00	\$ 317.00	
10	EARTH EXCAVATION	CU YD	995	\$ 40.00	\$ 39,800.00	
11	REMOVAL AND DISPOSAL OF UNSUITABLE MATERIAL	CU YD	730	\$ 10.00	\$ 7,300.00	
12	TRENCH BACKFILL	CU YD	1,810	\$ 30.00	\$ 54,300.00	
13	GEOTECHNICAL FABRIC FOR GROUND STABILIZATION	SQ YD	3,800	\$ 1.00	\$ 3,800.00	
14	TRIAxIAL GEOGRID REINFORCEMENT	SQ YD	715	\$ 5.00	\$ 3,575.00	
15	TOPSOIL FURNISH AND PLACE, 4"	SQ YD	2,450	\$ 2.00	\$ 4,900.00	
16	EROSION CONTROL BLANKET	SQ YD	2,450	\$ 1.40	\$ 3,430.00	
17	SODDING, SALT TOLERANT	SQ YD	2,450	\$ 11.00	\$ 26,950.00	
18	SUPPLEMENTAL WATERING	UNIT	30	\$ 10.00	\$ 300.00	
19	TREE, ACER SACCHARUM (SUGAR MAPLE), 2" CALIPER, BALLED AND BURLAPPED	EACH	3	\$ 550.00	\$ 1,650.00	
20	HACKBERRY), 2" CALIPER, BALLED AND BURLAPPED	EACH	4	\$ 550.00	\$ 2,200.00	
21	TREE, QUERCUS RUBRA (RED OAK), 2" CALIPER, BALLED AND BURLAPPED	EACH	3	\$ 550.00	\$ 1,650.00	
22	AMERICAN LINDEN), 2" CALIPER, BALLED AND BURLAPPED	EACH	3	\$ 550.00	\$ 1,650.00	
23	TREE, ULMUS CARPINIFOLIA MORTON, (ACCOLADE ELM), 2" CALIPER, BALLED AND BURLAPPED	EACH	3	\$ 550.00	\$ 1,650.00	
24	TEMPORARY EROSION CONTROL SEEDING	POUND	208	\$ 5.50	\$ 1,144.00	

## SCHEDULE OF PRICES

A bid will be declared unacceptable if neither a unit price nor total price is shown.

County DuPage Local Public Agency Village of Villa ParkSection N/ARoute Charles Avenue

## Schedule for Single Bid

(For complete information covering these items, see plans and specifications)

25	PERIMETER EROSION BARRIER	FOOT	61	\$	5.00	\$	305.00
26	INLET FILTERS	EACH	44	\$	15.00	\$	660.00
27	AGGREGATE SUBGRADE IMPROVEMENT	CU YD	730	\$	10.00	\$	7,300.00
28	TEMPORARY ACCESS (PRIVATE ENTRANCE)	EACH	33	\$	50.00	\$	1,650.00
29	TEMPORARY ACCESS (COMMERCIAL ENTRANCE)	EACH	3	\$	100.00	\$	300.00
30	TEMPORARY ACCESS (ROAD)	EACH	5	\$	150.00	\$	750.00
31	SUBBASE GRANULAR MATERIAL, TYPE C	CU YD	39	\$	35.00	\$	1,365.00
32	AGGREGATE BASE COURSE, TYPE B 6"	SQ YD	3,729	\$	5.75	\$	21,441.75
33	HOT-MIX ASPHALT SURFACE REMOVAL - BUTT JOINT	SQ YD	115	\$	10.00	\$	1,150.00
34	HOT-MIX ASPHALT BINDER COURSE, IL-19.0, N50	TON	836	\$	73.00	\$	61,028.00
35	HOT-MIX ASPHALT SURFACE COURSE, IL-9.5, MIX "D", N50	TON	502	\$	88.00	\$	44,176.00
36	BITUMINOUS MATERIALS (TACK COAT)	POUND	1,134	\$	0.01	\$	11.34
37	HOT-MIX ASPHALT DRIVEWAY PAVEMENT, 4"	SQ YD	289	\$	48.00	\$	13,872.00
38	HOT-MIX ASPHALT DRIVEWAY PAVEMENT, 6"	SQ YD	29	\$	77.00	\$	2,233.00
39	PROTECTIVE COAT	SQ YD	600	\$	1.00	\$	600.00
40	PORTLAND CEMENT CONCRETE DRIVEWAY PAVEMENT, 6 INCH	SQ YD	277	\$	66.00	\$	18,282.00
41	PORTLAND CEMENT CONCRETE DRIVEWAY PAVEMENT, 8 INCH	SQ YD	84	\$	100.00	\$	8,400.00
42	PORTLAND CEMENT CONCRETE SIDEWALK 5 INCH	SQ FT	5,599	\$	6.30	\$	35,273.70
43	PORTLAND CEMENT CONCRETE SIDEWALK 6 INCH	SQ FT	456	\$	7.25	\$	3,306.00
44	PORTLAND CEMENT CONCRETE SIDEWALK 8 INCH	SQ FT	44	\$	10.00	\$	440.00
45	DETECTABLE WARNINGS	SQ FT	161	\$	25.00	\$	4,025.00
46	PAVEMENT REMOVAL	SQ YD	3,728	\$	12.60	\$	46,972.80
47	DRIVEWAY PAVEMENT REMOVAL	SQ YD	558	\$	10.00	\$	5,580.00
48	COMBINATION CURB AND GUTTER REMOVAL	FOOT	2,650	\$	4.50	\$	11,925.00
49	SIDEWALK REMOVAL	SQ FT	6,194	\$	1.00	\$	6,194.00
50	CLASS D PATCHES, 14 INCH	SQ YD	130	\$	112.00	\$	14,560.00
51	STRUCTURE EXCAVATION	CU YD	20	\$	45.00	\$	900.00
52	CONCRETE STRUCTURES	CU YD	4	\$	2,000.00	\$	8,000.00
53	PROTECTIVE COAT	SQ YD	16	\$	1.00	\$	16.00
54	REINFORCEMENT BARS, EPOXY COATED	POUND	400	\$	3.00	\$	1,200.00
55	PIPE HANDRAIL	FOOT	23	\$	275.00	\$	6,325.00
56	STORM SEWERS, CLASS A, 12"	FOOT	614	\$	74.00	\$	45,436.00

## SCHEDULE OF PRICES

A bid will be declared unacceptable if neither a unit price nor total price is shown.

County DuPage Local Public Agency Village of Villa ParkSection N/ARoute Charles Avenue

## Schedule for Single Bid

(For complete information covering these items, see plans and specifications)

57	STORM SEWERS, CLASS A, 15"	FOOT	271	\$ 85.00	\$ 23,035.00
58	STORM SEWERS, CLASS A, 18"	FOOT	195	\$ 98.00	\$ 19,110.00
59	STORM SEWERS, CLASS A, 21"	FOOT	71	\$ 110.00	\$ 7,810.00
60	PVC PIPE DRAINS SDR 26 ASTM D-2241 6"	FOOT	330	\$ 38.00	\$ 12,540.00
61	STORM SEWERS, WATER MAIN QUALITY PIPE, 12"	FOOT	63	\$ 100.00	\$ 6,300.00
62	STORM SEWERS, WATER MAIN QUALITY PIPE, 16"	FOOT	8	\$ 150.00	\$ 1,200.00
63	STORM SEWER REMOVAL	FOOT	257	\$ 1.00	\$ 257.00
64	DUCTILE IRON WATER MAIN 6"	FOOT	6	\$ 110.00	\$ 660.00
65	DUCTILE IRON WATER MAIN 8"	FOOT	1,320	\$ 110.00	\$ 145,200.00
66	WATER MAIN REMOVAL	FOOT	875	\$ 1.00	\$ 875.00
67	ABANDON EXISTING WATER MAIN	L SUM	1	\$ 10,000.00	\$ 10,000.00
68	MJ CAP	EACH	11	\$ 550.00	\$ 6,050.00
69	FIRE HYDRANTS TO BE REMOVED	EACH	5	\$ 750.00	\$ 3,750.00
70	FIRE HYDRANT WITH AUXILIARY VALVE AND VALVE BOX	EACH	7	\$ 7,500.00	\$ 52,500.00
71	WATER SERVICE CONNECTION (SHORT), 1"	EACH	19	\$ 1,760.00	\$ 33,440.00
72	WATER SERVICE CONNECTION (LONG), 1"	EACH	20	\$ 3,450.00	\$ 69,000.00
73	WATER SERVICE CURB BOX	EACH	39	\$ 60.00	\$ 2,340.00
74	CONNECTION TO EXISTING WATER MAIN 6"	EACH	2	\$ 4,600.00	\$ 9,200.00
75	CONNECTION TO EXISTING WATER MAIN 12"	EACH	1	\$ 6,450.00	\$ 6,450.00
76	PRESSURE CONNECTION TO EXISTING WATER MAIN 12"	EACH	1	\$ 5,750.00	\$ 5,750.00
77	VALVE VAULT, 4' DIAMETER, TYPE 1 FRAME, CLOSED LID	EACH	2	\$ 3,450.00	\$ 6,900.00
78	VALVE VAULT, 5' DIAMETER, TYPE 1 FRAME, CLOSED LID	EACH	1	\$ 4,000.00	\$ 4,000.00
79	WATER VALVE 8"	EACH	2	\$ 1,650.00	\$ 3,300.00
80	WATER MAIN INSULATION	SQ FT	500	\$ 3.00	\$ 1,500.00
81	STEEL CASING PIPE IN TRENCH, 16-INCH	FOOT	35	\$ 135.00	\$ 4,725.00
82	SANITARY SEWER, REMOVE AND REPLACE, 6-INCH DIAMETER OR LESS	FOOT	655	\$ 96.00	\$ 62,880.00
83	SANITARY SEWER, REMOVE AND REPLACE, OVER 6- INCH DIAMETER	FOOT	204	\$ 168.00	\$ 34,272.00
84	SANITARY SEWER SERVICE CONNECTION, REMOVE & REPLACE	EACH	30	\$ 1,250.00	\$ 37,500.00

## SCHEDULE OF PRICES

A bid will be declared unacceptable if neither a unit price nor total price is shown.

County DuPage Local Public Agency Village of Villa ParkSection N/ARoute Charles Avenue

## Schedule for Single Bid

(For complete information covering these items, see plans and specifications)

85	REMOVE EXISTING SANITARY SEWER SERVICE CONNECTION AND ABANDON IN PLACE	EACH	11	\$ 1,000.00	\$ 11,000.00
86	ABANDON EXISTING COMBINED SEWER	L SUM	1	\$ 3,000.00	\$ 3,000.00
87	ADJUSTING SANITARY SEWER SERVICE LINE	FOOT	100	\$ 25.00	\$ 2,500.00
88	PROTRUDING TAP REMOVAL	EACH	3	\$ 165.00	\$ 495.00
89	CIPP LINER FOR SANITARY SEWER MAIN 10"	FOOT	601	\$ 51.00	\$ 30,651.00
90	SEWER LINING-LATERAL REINSTATEMENT	EACH	22	\$ 83.00	\$ 1,826.00
91	SEWER ROOT FOAM TREATMENT	FOOT	1,131	\$ 3.00	\$ 3,393.00
92	SEWER DYE TESTING	EACH	15	\$ 468.00	\$ 7,020.00
93	SANITARY SEWER MANHOLE, 4'-DIAMETER, TYPE 1 FRAME, CLOSED LID	EACH	2	\$ 6,000.00	\$ 12,000.00
94	SEWER SERVICE CLEANOUT	EACH	40	\$ 685.00	\$ 27,400.00
95	SEWER SERVICE CHECK VALVE	EACH	30	\$ 875.00	\$ 26,250.00
96	SEWER SERVICE FRAME AND LID	EACH	40	\$ 213.00	\$ 8,520.00
97	COMBINATION CONCRETE CURB AND GUTTER, TYPE B-4.12	FOOT	7	\$ 22.00	\$ 154.00
98	COMBINATION CONCRETE CURB AND GUTTER, TYPE B-6.12	FOOT	2,652	\$ 22.00	\$ 58,344.00
99	CONCRETE CURB, TYPE B	FOOT	23	\$ 30.00	\$ 690.00
100	PIPE UNDERDRAINS, TYPE 1, 6"	FOOT	70	\$ 38.00	\$ 2,660.00
101	CATCH BASINS, TYPE A, 4'-DIAMETER	EACH	17	\$ 3,050.00	\$ 51,850.00
102	CATCH BASINS, TYPE C	EACH	11	\$ 1,500.00	\$ 16,500.00
103	MANHOLES, TYPE A, 4'-DIAMETER	EACH	9	\$ 3,200.00	\$ 28,800.00
104	MANHOLES, TYPE A, 7'-DIAMETER	EACH	1	\$ 9,200.00	\$ 9,200.00
105	TYPE 1 FRAME, CLOSED LID	EACH	10	\$ 460.00	\$ 4,600.00
106	TYPE 11 FRAME AND GRATE	EACH	6	\$ 600.00	\$ 3,600.00
107	TYPE 11V FRAME AND GRATE	EACH	22	\$ 600.00	\$ 13,200.00
108	VALVE VAULTS TO BE ADJUSTED	EACH	1	\$ 400.00	\$ 400.00
109	DRAINAGE & UTILITY STRUCTURES TO BE ADJUSTED	EACH	14	\$ 400.00	\$ 5,600.00
110	DRAINAGE & UTILITY STRUCTURES TO BE RECONSTRUCTED	EACH	1	\$ 1,500.00	\$ 1,500.00
111	DRAINAGE STRUCTURES TO BE REMOVED	EACH	11	\$ 350.00	\$ 3,850.00
112	VALVE VAULTS TO BE ABANDONED	EACH	2	\$ 350.00	\$ 700.00
113	THERMOPLASTIC PAVEMENT MARKINGS - LINE 6"	FOOT	384	\$ 6.60	\$ 2,534.40
114	THERMOPLASTIC PAVEMENT MARKINGS - LINE 24"	FOOT	60	\$ 26.40	\$ 1,584.00

**SCHEDULE OF PRICES**

A bid will be declared unacceptable if neither a unit price nor total price is shown.  
 County DuPage Local Public Agency Village of Villa Park  
 Section N/A  
 Route Charles Avenue

**Schedule for Single Bid**

(For complete information covering these items, see plans and specifications)

115	TRAFFIC CONTROL AND PROTECTION (SPECIAL)	L SUM	1	\$ 81,000.00	\$ 81,000.00
116	CONSTRUCTION LAYOUT	L SUM	1	\$ 30,000.00	\$ 30,000.00
117	PRE-CONSTRUCTION VIDEO RECORDING	L SUM	1	\$ 16,000.00	\$ 16,000.00
118	WATER USAGE DEDUCTION	TGAL	-100	\$ 8.85	\$ (885.00)
119	WATER USAGE CREDIT	TGAL	100	\$ 8.85	\$ 885.00
120	CONTINGENCY ALLOWANCE	DOLLAR	50,000	\$ 1.00	\$ 50,000.00
121	HOT-MIX ASPHALT SURFACE REMOVAL, 2"	SQ YD	660	\$ 3.00	\$ 1,980.00
122	TEMPORARY RAMP	SQ YD	100	\$ 10.00	\$ 1,000.00
123	THERMOPLASTIC PAVEMENT MARKINGS - LINE 4"	FOOT	120	\$ 4.40	\$ 528.00

RETURN WITH BID

CONTRACTOR CERTIFICATIONS

County	<u>DuPage</u>
Local Public Agency	<u>Village of Villa Park</u>
Section Number	<u>N/A</u>
Route	<u>Charles Avenue</u>

The certifications hereinafter made by the bidder are each a material representation of fact upon which reliance is placed should the Department enter into the contract with the bidder.

1. **Debt Delinquency.** The bidder or contractor or subcontractor, respectively, certifies that it is not delinquent in the payment of any tax administered by the Department of Revenue unless the individual or other entity is contesting, in accordance with the procedures established by the appropriate revenue Act, its liability for the tax or the amount of tax. Making a false statement voids the contract and allows the Department to recover all amounts paid to the individual or entity under the contract in a civil action.

2. **Bid-Rigging or Bid Rotating.** The bidder or contractor or subcontractor, respectively, certifies that it is not barred from contracting with the Department by reason of a violation of either 720 ILCS 5/33E-3 or 720 ILCS 5/33E-4.

A violation of Section 33E-3 would be represented by a conviction of the crime of bid-rigging which, in addition to Class 3 felony sentencing, provides that any person convicted of this offense or any similar offense of any state or the United States which contains the same elements as this offense shall be barred for 5 years from the date of conviction from contracting with any unit of State or local government. No corporation shall be barred from contracting with any unit of State or local government as a result of a conviction under this Section of any employee or agent of such corporation if the employee so convicted is no longer employed by the corporation and: (1) it has been finally adjudicated not guilty or (2) if it demonstrates to the governmental entity with which it seeks to contract and that entity finds that the commission of the offense was neither authorized, requested, commanded, nor performed by a director, officer or a high managerial agent in behalf of the corporation.

A violation of Section 33E-4 would be represented by a conviction of the crime of bid-rotating which, in addition to Class 2 felony sentencing, provides that any person convicted of this offense or any similar offense of any state or the United States which contains the same elements as this offense shall be permanently barred from contracting with any unit of State or local government. No corporation shall be barred from contracting with any unit of State or local government as a result of a conviction under this Section of any employee or agent of such corporation if the employee so convicted is no longer employed by the corporation and: (1) it has been finally adjudicated not guilty or (2) if it demonstrates to the governmental entity with which it seeks to contract and that entity finds that the commission of the offense was neither authorized, requested, commanded, nor performed by a director, officer or a high managerial agent in behalf of the corporation.

3. **Bribery.** The bidder or contractor or subcontractor, respectively, certifies that it has not been convicted of bribery or attempting to bribe an officer or employee of the State of Illinois or any unit of local government, nor has the firm made an admission of guilt of such conduct which is a matter of record, nor has an official, agent, or employee of the firm committed bribery or attempted bribery on behalf of the firm and pursuant to the direction or authorization of a responsible official of the firm.

4. **Interim Suspension or Suspension.** The bidder or contractor or subcontractor, respectively, certifies that it is not currently under a suspension as defined in Subpart I of Title 44 Subtitle A Chapter III Part 6 of the Illinois Administrative Code. Furthermore, if suspended prior to completion of this work, the contract or contracts executed for the completion of this work may be cancelled.

RETURN WITH BID

SIGNATURES

County DuPage  
 Local Public Agency Village of Villa Park  
 Section Number N/A  
 Route Charles Avenue

(If an individual)

Signature of Bidder \_\_\_\_\_

Business Address \_\_\_\_\_

(If a partnership)

Firm Name \_\_\_\_\_

Signed By \_\_\_\_\_

Business Address \_\_\_\_\_

Inset Names and Addressed of All Partners

\_\_\_\_\_

\_\_\_\_\_

\_\_\_\_\_

\_\_\_\_\_

(If a corporation)

Corporate Name A Lamp Concrete Contractors, Inc.

Signed By *Adele Lampignano*  
President

Business Address 1900 Wright Boulevard  
Schaumburg, IL 60193

Insert Names of Officers

President Adele Lampignano

Secretary Tracy Lampignano

Treasurer Adele Lampignano

Attest:

*TC*

Secretary





Local Agency Proposal Bid Bond

Route Charles Avenue
County DuPage
Local Agency Village of Villa Park
Section N/A

RETURN WITH BID

PAPER BID BOND
WE A. Lamp Concrete Contractors, Inc. as PRINCIPAL,

and The Hanover Insurance Company as SURETY,

are held jointly, severally and firmly bound unto the above Local Agency (hereafter referred to as "LA") in the penal sum of 5% of the total bid price, or for the amount specified in the proposal documents in effect on the date of invitation for bids whichever is the lesser sum. We bind ourselves, our heirs, executors, administrators, successors, and assigns, jointly pay to the LA this sum under the conditions of this instrument.

WHEREAS THE CONDITION OF THE FOREGOING OBLIGATION IS SUCH that, the said PRINCIPAL is submitting a written proposal to the LA acting through its awarding authority for the construction of the work designated as the above section.

THEREFORE if the proposal is accepted and a contract awarded to the PRINCIPAL by the LA for the above designated section and the PRINCIPAL shall within fifteen (15) days after award enter into a formal contract, furnish surety guaranteeing the faithful performance of the work, and furnish evidence of the required insurance coverage, all as provided in the "Standard Specifications for Road and Bridge Construction" and applicable Supplemental Specifications, then this obligation shall become void; otherwise it shall remain in full force and effect.

IN THE EVENT the LA determines the PRINCIPAL has failed to enter into a formal contract in compliance with any requirements set forth in the preceding paragraph, then the LA acting through its awarding authority shall immediately be entitled to recover the full penal sum set out above, together with all court costs, all attorney fees, and any other expense of recovery.

IN TESTIMONY WHEREOF, the said PRINCIPAL and the said SURETY have caused this instrument to be signed by their respective officers this 6th day of July 2021

Principal

A. Lamp Concrete Contractors, Inc.
(Company Name)
By: Adele Lampignano, President
(Signature and Title)

(Company Name)
(Signature and Title)

(If PRINCIPAL is a joint venture of two or more contractors, the company names, and authorized signatures of each contractor must be affixed.)

Surety

The Hanover Insurance Company
(Name of Surety)

By: Thomas O. Chambers
(Signature of Attorney-in-Fact)

STATE OF WISCONSIN
COUNTY OF Racine

I, Jackie Sheldon, a Notary Public in and for said county, do hereby certify that Adele Lampignano and Thomas O. Chambers

(Insert names of individuals signing on behalf of PRINCIPAL & SURETY)

who are each personally known to me to be the same persons whose names are subscribed to the foregoing instrument on behalf of PRINCIPAL and SURETY, appeared before me this day in person and acknowledged respectively, that they signed and delivered said instruments as their free and voluntary act for the uses and purposes therein set forth.

Given under my hand and notarial seal this 6th day of July 2021

My commission expires 2/13/2023

Jackie Sheldon
(Notary Public)

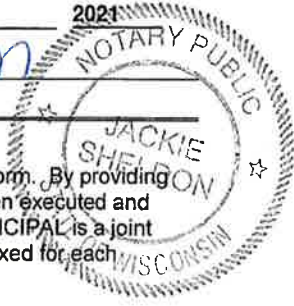

ELECTRONIC BID BOND

Electronic bid bond is allowed (box must be checked by LA if electronic bid bond is allowed)

The Principal may submit an electronic bid bond, in lieu of completing the above section of the Proposal Bid Bond Form. By providing an electronic bid bond ID code and signing below, the Principal is ensuring the identified electronic bid bond has been executed and the Principal and Surety are firmly bound unto the LA under the conditions of the bid bond as shown above. (If PRINCIPAL is a joint venture of two or more contractors, an electronic bid bond ID code, company/Bidder name title and date must be affixed for each contractor in the venture.)

Electronic Bid Bond ID Code

(Company/Bidder Name)

(Signature and Title)

Date

THE HANOVER INSURANCE COMPANY
MASSACHUSETTS BAY INSURANCE COMPANY
CITIZENS INSURANCE COMPANY OF AMERICA

POWER OF ATTORNEY

THIS Power of Attorney limits the acts of those named herein, and they have no authority to bind the Company except in the manner and to the extent herein stated.

KNOW ALL PERSONS BY THESE PRESENTS:

That THE HANOVER INSURANCE COMPANY and MASSACHUSETTS BAY INSURANCE COMPANY, both being corporations organized and existing under the laws of the State of New Hampshire, and CITIZENS INSURANCE COMPANY OF AMERICA, a corporation organized and existing under the laws of the State of Michigan, (hereinafter individually and collectively the "Company") does hereby constitute and appoint,

Thomas O. Chambers, Todd SchAAP, Daniel Gibson, Eric Olson, Kimberly S. Rasch, Jackle Sheldon and/or Josie Benson

Of Shorewest Surety Services, Inc. of Racine, WI each individually, if there be more than one named, as its true and lawful attorney(s)-in-fact to sign, execute, seal, acknowledge and deliver for, and on its behalf, and as its act and deed any place within the United States, any and all surety bonds, recognizances, undertakings, or other surety obligations. The execution of such surety bonds, recognizances, undertakings or surety obligations, in pursuance of these presents, shall be as binding upon the Company as if they had been duly signed by the president and attested by the secretary of the Company, in their own proper persons. Provided however, that this power of attorney limits the acts of those named herein; and they have no authority to bind the Company except in the manner stated and to the extent of any limitation stated below:

Any such obligations in the United States, not to exceed Forty Million and No/100 (\$40,000,000) in any single instance

That this power is made and executed pursuant to the authority of the following Resolutions passed by the Board of Directors of said Company, and said Resolutions remain in full force and effect:

RESOLVED: That the President or any Vice President, in conjunction with any Vice President, be and they hereby are authorized and empowered to appoint Attorneys-in-fact of the Company, in its name and as it acts, to execute and acknowledge for and on its behalf as surety, any and all bonds, recognizances, contracts of indemnity, waivers of citation and all other writings obligatory in the nature thereof, with power to attach thereto the seal of the Company. Any such writings so executed by such Attorneys-in-fact shall be binding upon the Company as if they had been duly executed and acknowledged by the regularly elected officers of the Company in their own proper persons.

RESOLVED: That any and all Powers of Attorney and Certified Copies of such Powers of Attorney and certification in respect thereto, granted and executed by the President or Vice President in conjunction with any Vice President of the Company, shall be binding on the Company to the same extent as if all signatures therein were manually affixed, even though one or more of any such signatures thereon may be facsimile. (Adopted October 7, 1981 - The Hanover Insurance Company; Adopted April 14, 1982 - Massachusetts Bay Insurance Company; Adopted September 7, 2001 - Citizens Insurance Company of America)

IN WITNESS WHEREOF, THE HANOVER INSURANCE COMPANY, MASSACHUSETTS BAY INSURANCE COMPANY and CITIZENS INSURANCE COMPANY OF AMERICA have caused these presents to be sealed with their respective corporate seals, duly attested by two Vice Presidents, this 15th day of March, 2017.

The Hanover Insurance Company
Massachusetts Bay Insurance Company
Citizens Insurance Company of America

John C. Roche, EVP and President



The Hanover Insurance Company
Massachusetts Bay Insurance Company
Citizens Insurance Company of America

James H. Kawiecki, Vice President

THE COMMONWEALTH OF MASSACHUSETTS )
COUNTY OF WORCESTER ) ss.

On this 15th day of March, 2017 before me came the above named Vice Presidents of The Hanover Insurance Company, Massachusetts Bay Insurance Company and Citizens Insurance Company of America, to me personally known to be the individuals and officers described herein, and acknowledged that the seals affixed to the preceding instrument are the corporate seals of The Hanover Insurance Company, Massachusetts Bay Insurance Company and Citizens Insurance Company of America, respectively, and that the said corporate seals and their signatures as officers were duly affixed and subscribed to said instrument by the authority and direction of said Corporations.

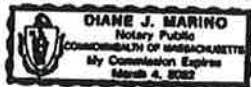

Diane J. Marino, Notary Public
My Commission Expires March 4, 2022

I, the undersigned Vice President of The Hanover Insurance Company, Massachusetts Bay Insurance Company and Citizens Insurance Company of America, hereby certify that the above and foregoing is a full, true and correct copy of the Original Power of Attorney Issued by said Companies, and do hereby further certify that the said Powers of Attorney are still in force and effect.

GIVEN under my hand and the seals of said Companies, at Worcester, Massachusetts, this 6th day of July 2021

CERTIFIED COPY

Theodore G. Martinez, Vice President



Affidavit of Availability  
For the Letting of 06/11/21

Instructions: Complete this form by either typing or using black ink. "Authorization to Bid" will not be issued unless both sides of this form are completed in detail. Use additional forms as needed to list all work.

**Part I. Work Under Contract**

List below all work you have under contract as either a prime contractor or a subcontractor. It is required to include all pending low bids not yet awarded or rejected. In a joint venture, list only that portion of the work which is the responsibility of your company. The uncompleted dollar value is to be based upon the most recent engineer's or owners estimate, and must include work subcontracted to others. If no work is contracted, show NONE

	1	2	3	4	5	
Contract Number						
Contract With	Carpentersville	Franklin Park	Downers Grove	Downers Grove	Wilmette PD	
Estimated Completion Date	30 Working Days	11/1/2020	6/11/2021	10/1/2021	5/28/2021	
Total Contract Price	\$ 379,642.90	\$83,660.00	\$ 179,432.77	\$ 4,068,833.52	\$ 859,760.20	Accumulated Totals
Uncompleted Dollar Value if Firm is the Prime Contractor	\$ 379,642.90	\$ 16,715.00	\$ -	\$ 2,373,962.62	\$ 711,545.00	\$ 3,481,865.52
Uncompleted Dollar Value if Firm is the Subcontractor						\$ -
<b>Total Value of All Work</b>						<b>\$ 3,481,865.52</b>

**Part II. Awards Pending and Uncompleted Work to be done with your own forces.**

List below the uncompleted dollar value of work for each contract and awards pending to be completed with your own forces. All work subcontracted to others will be listed on the reverse of this form. In a joint venture, list only that portion of the work to be done by your company. If no work is contracted, show NONE

						Accumulated Totals
Earthwork	\$19,486.00	\$0.00		\$600,000.00	\$130,000.00	\$ 749,486.00
Portland Cement Concrete Paving	\$ -					\$ -
HMA Plant Mix		\$ -				\$ -
HMA Paving	\$115,982.00			\$340,000.00	\$256,680.00	\$ 712,662.00
Clean & Seal Cracks/ Joints						\$ -
Aggregate Bases & Surfaces		\$0.00		\$35,843.00	\$150,000.00	\$ 185,843.00
Highway,R.R.& Water Structures						\$ -
Drainage	\$28,022.00	\$0.00		\$600,000.00	\$1,500.00	\$ 629,522.00
Electrical						\$ -
Cover and Seal Coats						\$ -
Concrete Construction	\$169,765.00			\$90,000.00	\$103,540.00	\$ 363,305.00
Landscaping	\$3,375.00	\$2,040.00	\$0.00	\$319,496.65	\$33,000.00	\$ 357,911.65
Fencing	\$2,812.50					\$ 2,812.50
Guardrail						\$ -
Painting						\$ -
Signing		\$2,500.00				\$ 2,500.00
Cold Milling, Planning & Rotomilling	\$8,541.40			\$20,000.00	\$6,825.00	\$ 35,366.40
Demolition						\$ -
Pavement Markings (Paint)						\$ -
Other Construction (List)	\$28,004.00	\$5,000.00		\$300,000.00	\$30,000.00	\$ 363,004.00
						\$ -
<b>Totals</b>	<b>\$ 375,987.90</b>	<b>\$ 9,540.00</b>	<b>\$ -</b>	<b>\$ 2,305,339.65</b>	<b>\$ 711,645.00</b>	<b>\$ 3,402,412.55</b>

Disclosure of this information is REQUIRED to accomplish the statutory purpose as outlined in the "Illinois Procurement Code." Failure to comply will result in non-issuance of an "Authorization to Bid." This form has been approved by the State Forms Management Center.

**Part III. Work Subcontracted to Others**

For each contract described in Part I, list all the work you have subcontracted to others.

	1	2	3	4	5
Subcontractor					
Type of Work	Pavement Marking	Pavement Marking	Layout	Fencing	Layout
Subcontract Price	\$3,655.00	\$7,175.00	\$3,000.00	\$21,780.50	\$12,000.00
Amount Uncompleted	\$3,655.00	\$7,175.00	\$0.00	\$21,780.50	\$0.00
Subcontractor					
Type of Work			Pavement Marking	Layout	Pavement Marking
Subcontract Price			\$2,520.00	\$35,000.00	\$5,077.50
Amount Uncompleted			\$0.00	\$20,000.00	\$0.00
Subcontractor					
Type of Work			Site Video	Line Stops	Site Video
Subcontract Price			\$400.00	\$14,000.00	\$1,000.00
Amount Uncompleted			\$0.00	\$7,000.00	\$0.00
Subcontractor					
Type of Work			Tree Care	Pavement Marking	Tree Care
Subcontract Price			\$4,220.00	\$12,342.47	\$4,478.00
Amount Uncompleted			\$0.00	\$12,342.47	\$0.00
Subcontractor					
Type of Work				Site Video	
Subcontract Price				\$2,700.00	
Amount Uncompleted				\$0.00	
Subcontractor					
Type of Work				Tree Care	
Subcontract Price				\$25,470.50	
Amount Uncompleted			\$ -	\$7,500.00	
Subcontractor					
Type of Work					
Subcontract Price					
Amount Uncompleted			\$ -	\$ -	\$ -
Subcontractor					
Type of Work					
Subcontract Price					
Amount Uncompleted					
Subcontractor					
Type of Work					
Subcontract Price					
Amount Uncompleted					
Subcontractor					
Type of Work					
Subcontract Price					
Amount Uncompleted					





**Illinois Department of Transportation**  
 Bureau of Construction  
 2300 South Dirksen Parkway/Room 302  
 Springfield, Illinois 62761

Affidavit of Availability  
 For the Letting of 06/11/21

Instructions: Complete this form by either typing or using black ink. "Authorization to Bid" will not be issued unless both sides of this form are completed in detail. Use additional forms as needed to list all work.

**Part I. Work Under Contract**

List below all work you have under contract as either a prime contractor or a subcontractor. It is required to include all pending low bids not yet awarded or rejected. In a joint venture, list only that portion of the work which is the responsibility of your company. The uncompleted dollar value is to be based upon the most recent engineer's or owners estimate, and must include work subcontracted to others. If no work is contracted, show NONE

	6	7	8	9	10	
Contract Number	AU069	61G35			61G70	
Contract With	IDOT	IDOT	East Dundee	LCDOT	IDOT	
Estimated Completion Date	90 Calendar Days	7/31/2021	6/30/2021	11/20/2021	11/13/2021	
Total Contract Price	\$ 499,302.00	\$3,089,999.80	\$ 198,517.50	\$ 4,544,617.36	\$ 4,849,824.59	Accumulated Totals
Uncompleted Dollar Value if Firm is the Prime Contractor	\$ 499,302.00	\$ 732,697.00	\$ 124,411.00	\$ 4,544,617.36	\$ 3,230,184.90	\$ 9,131,212.26
Uncompleted Dollar Value if Firm is the Subcontractor		\$ -				\$ -
<b>Total Value of All Work</b>						<b>\$ 9,131,212.26</b>

**Part II. Awards Pending and Uncompleted Work to be done with your own forces.**

List below the uncompleted dollar value of work for each contract and awards pending to be completed with your own forces. All work subcontracted to others will be listed on the reverse of this form. In a joint venture, list only that portion of the work to be done by your company. If no work is contracted, show NONE

						Accumulated Totals
Earthwork	\$117,880.00	\$10,000.00	\$7,500.00	\$495,350.20	\$380,000.00	\$ 1,010,730.20
Portland Cement Concrete Paving		\$350,000.00			\$ -	\$ 350,000.00
HMA Plant Mix						\$ -
HMA Paving	\$107,062.00	\$15,000.00	\$18,487.00	\$266,243.25	\$106,792.00	\$ 513,584.25
Clean & Seal Cracks/ Joints						\$ -
Aggregate Bases & Surfaces	\$57,740.00	\$10,000.00	\$5,000.00	\$163,354.00	\$150,000.00	\$ 386,094.00
Highway, R.R. & Water Structures		\$ -				\$ -
Drainage		\$4,500.00	\$2,000.00	\$515,017.00	\$60,000.00	\$ 581,517.00
Electrical						\$ -
Cover and Seal Coats						\$ -
Concrete Construction	\$106,300.00	\$60,000.00	\$19,374.00	\$205,924.25	\$750,000.00	\$ 1,141,598.25
Landscaping		\$28,069.00	\$40,000.00	\$8,900.00		\$ 76,969.00
Fencing						\$ -
Guardrail						\$ -
Painting						\$ -
Signing		\$21,366.00				\$ 21,366.00
Cold Milling, Planning & Rotomilling	\$17,452.50	\$820.00		\$137,643.15	\$250,000.00	\$ 405,915.65
Demolition		\$ -				\$ -
Pavement Markings (Paint)						\$ -
Other Construction (List)	\$14,000.00	\$15,000.00	\$25,000.00	\$663,306.13	\$130,000.00	\$ 847,306.13
						\$ -
<b>Totals</b>	<b>\$ 420,434.50</b>	<b>\$ 514,755.00</b>	<b>\$ 117,361.00</b>	<b>\$ 2,455,737.98</b>	<b>\$ 1,826,792.00</b>	<b>\$ 5,335,080.48</b>

Disclosure of this information is **REQUIRED** to accomplish the statutory purpose as outlined in the "Illinois Procurement Code." Failure to comply will result in non-issuance of an "Authorization to Bid." This form has been approved by the State Forms Management Center.

**Part III. Work Subcontracted to Others**

For each contract described in Part I, list all the work you have subcontracted to others.

	6	7	8	9	10
Subcontractor					
Type of Work	Landscaping	Electrical	Guardrail	HMA Paving	HMA Paving
Subcontract Price	\$20,602.50	\$387,471.05	\$7,050.00	\$1,455,797.24	\$1,141,818.53
Amount Uncompleted	\$20,602.50	\$200,000.00	\$7,050.00	\$1,455,797.24	\$900,000.00
Subcontractor					
Type of Work	Pavement Marking	Guardrail	Tree Care	Electrical	LJS
Subcontract Price	\$19,955.00	\$8,587.50	\$3,696.00	\$135,956.80	\$35,947.95
Amount Uncompleted	\$19,955.00	\$8,587.50	\$0.00	\$135,956.80	\$35,947.95
Subcontractor					
Type of Work	Sewer	Pavement Marking		Fencing	Electrical
Subcontract Price	\$38,310.00	\$9,354.50		\$172,703.25	\$4,750.00
Amount Uncompleted	\$38,310.00	\$9,354.50		\$172,703.25	\$4,750.00
Subcontractor					
Type of Work		Environmental		Landscaping	Environmental
Subcontract Price		\$19,615.00		\$127,944.70	\$11,380.00
Amount Uncompleted		\$0.00		\$127,944.70	\$7,500.00
Subcontractor					
Type of Work				Layout	Landscaping
Subcontract Price				\$61,650.00	\$106,554.20
Amount Uncompleted				\$61,650.00	\$106,554.20
Subcontractor					
Type of Work				LJS	Layout
Subcontract Price				\$49,180.90	\$62,000.00
Amount Uncompleted				\$49,180.90	\$40,000.00
Subcontractor					
Type of Work				Pavement Marking	Pavement Marking
Subcontract Price				\$62,796.49	\$48,640.75
Amount Uncompleted				\$62,796.49	\$48,640.75
Subcontractor					
Type of Work				Tree Care	Underground
Subcontract Price				\$22,850.00	\$585,507.00
Amount Uncompleted				\$22,850.00	\$35,000.00
Subcontractor					
Type of Work					Traffic Control
Subcontract Price					\$440,143.56
Amount Uncompleted					\$225,000.00
Subcontractor					
Type of Work					
Subcontract Price					
Amount Uncompleted					
Subcontractor					
Type of Work					
Subcontract Price					
Amount Uncompleted					
<b>Total Uncompleted</b>	<b>\$78,867.50</b>	<b>\$ 217,942.00</b>	<b>\$ 7,050.00</b>	<b>\$ 2,088,879.38</b>	<b>\$ 1,403,392.90</b>
<b>Totals</b>	<b>\$78,867.50</b>	<b>\$ 425,028.05</b>	<b>\$ 10,746.00</b>	<b>\$ 2,088,879.38</b>	<b>\$ 2,436,741.99</b>



Affidavit of Availability  
 For the Letting of 06/11/21

Instructions: Complete this form by either typing or using black ink. "Authorization to Bid" will not be issued unless both sides of this form are completed in detail. Use additional forms as needed to list all work.

**Part I. Work Under Contract**

List below all work you have under contract as either a prime contractor or a subcontractor. It is required to include all pending low bids not yet awarded or rejected. In a joint venture, list only that portion of the work which is the responsibility of your company. The uncompleted dollar value is to be based upon the most recent engineer's or owners estimate, and must include work subcontracted to others. If no work is contracted, show NONE

	11	12	13	14	15	
Contract Number	61G72	61G83		61G42		
Contract With	IDOT	IDOT	Downers Grove	IDOT	Wheaton	
Estimated Completion Date	25 Working Days	8/6/2021	11/20/2020	9/30/2021	11/1/2021	
Total Contract Price	\$ 149,541.00	\$ 1,569,267.50	\$604,969.60	\$ 9,504,078.67	\$ 10,320,000.00	Accumulated Totals
Uncompleted Dollar Value if Firm is the Prime Contractor	\$ 42,830.00	\$ 353,574.05	\$ 349,208.10	\$ 2,452,940.92	\$ 6,662,122.50	\$ 9,860,675.57
Uncompleted Dollar Value if Firm is the Subcontractor						\$ -
<b>Total Value of All Work</b>						<b>\$ 9,860,675.57</b>

**Part II. Awards Pending and Uncompleted Work to be done with your own forces.**

List below the uncompleted dollar value of work for each contract and awards pending to be completed with your own forces. All work subcontracted to others will be listed on the reverse of this form. In a joint venture, list only that portion of the work to be done by your company. If no work is contracted, show NONE

						Accumulated Totals
Earthwork		\$3,500.00	\$10,000.00	\$320,000.00	\$420,000.00	\$ 753,500.00
Portland Cement Concrete Paving						\$ -
HMA Plant Mix						\$ -
HMA Paving		\$180,000.00	\$33,983.10	\$800,000.00	\$560,000.00	\$ 1,573,983.10
Clean & Seal Cracks/ Joints						\$ -
Aggregate Bases & Surfaces			\$4,188.10	\$200,000.00	\$41,522.50	\$ 245,710.60
Highway, R.R. & Water Structures						\$ -
Drainage		\$3,500.00	\$20,000.00	\$20,000.00	\$140,000.00	\$ 183,500.00
Electrical						\$ -
Cover and Seal Coats						\$ -
Concrete Construction			\$120,000.00	\$200,000.00	\$1,250,000.00	\$ 1,570,000.00
Landscaping						\$ -
Fencing						\$ -
Guardrail						\$ -
Painting						\$ -
Signing	\$1,030.00	\$6,920.00	\$900.00			\$ 8,850.00
Cold Milling, Planning & Rotomilling			\$4,805.00		\$80,000.00	\$ 84,805.00
Demolition						\$ -
Pavement Markings (Paint)						\$ -
Other Construction (List)	\$1,000.00	\$5,000.00	\$20,000.00	\$30,000.00	\$720,000.00	\$ 776,000.00
						\$ -
<b>Totals</b>	<b>\$ 2,030.00</b>	<b>\$ 198,920.00</b>	<b>\$ 213,876.20</b>	<b>\$ 1,570,000.00</b>	<b>\$ 3,211,522.50</b>	<b>\$ 5,196,348.70</b>

Disclosure of this information is REQUIRED to accomplish the statutory purpose as outlined in the "Illinois Procurement Code." Failure to comply will result in non-issuance of an "Authorization to Bid." This form has been approved by the State Forms Management Center.

**Part III. Work Subcontracted to Others**

For each contract described in Part I, list all the work you have subcontracted to others.

	11	12	13	14	15
Subcontractor					
Type of Work	Electrical		Fencing	Brick Paving	Brick Paving
Subcontract Price	\$40,800.00	\$0.00	\$36,900.00	\$94,757.00	\$202,969.25
Amount Uncompleted	\$40,800.00	\$0.00	\$36,900.00	\$30,000.00	\$180,000.00
Subcontractor					
Type of Work	Layout	Electrical	Landscaping	Sewer Lining	Building Construction
Subcontract Price	\$5,000.00	\$158,594.00	\$75,660.40	\$110,081.25	\$1,135,000.00
Amount Uncompleted	\$0.00	\$100,000.00	\$75,660.40	\$110,081.25	\$1,135,000.00
Subcontractor					
Type of Work	Pavement Marking	Landscaping	Layout	Electrical	Electrical
Subcontract Price	\$4,185.00	\$25,801.40	\$7,200.00	\$748,329.02	\$2,318,000.00
Amount Uncompleted	\$0.00	\$25,801.40	\$7,200.00	\$250,000.00	\$1,500,000.00
Subcontractor					
Type of Work		Layout	Pavement Marking	Vibration Monitoring	Fencing
Subcontract Price		\$9,500.00	\$3,096.50	\$285,000.00	\$353,390.00
Amount Uncompleted		\$0.00	\$3,096.50	\$0.00	\$300,000.00
Subcontractor					
Type of Work		Line Stops	Site Video	Irrigation	Landscaping
Subcontract Price		\$20,300.00	\$1,000.00	\$11,840.00	\$257,240.00
Amount Uncompleted		\$0.00	\$1,000.00	\$6,000.00	\$210,000.00
Subcontractor					
Type of Work		Pavement Marking	Tree Care	Landscaping	Layout
Subcontract Price		\$8,852.65	\$11,475.00	\$227,607.42	\$63,000.00
Amount Uncompleted		\$8,852.65	\$11,475.00	\$70,000.00	\$45,000.00
Subcontractor					
Type of Work		Traffic Control		Layout	Pavement Marking
Subcontract Price		\$172,803.30		\$108,000.00	\$40,000.00
Amount Uncompleted		\$20,000.00		\$30,000.00	\$40,000.00
Subcontractor					
Type of Work		Tree Care		Line Stops	Signage
Subcontract Price		\$4,400.00		\$37,000.00	\$39,600.00
Amount Uncompleted		\$0.00		\$0.00	\$39,600.00
Subcontractor					
Type of Work				Cracksealing	Site Video
Subcontract Price				\$183,240.75	\$5,000.00
Amount Uncompleted				\$183,240.75	\$0.00
Subcontractor					
Type of Work				Pavement Marking	Tree Care
Subcontract Price				\$63,618.92	\$16,722.00
Amount Uncompleted				\$63,618.92	\$1,000.00
Subcontractor					
Type of Work				Signage	
Subcontract Price				\$161,173.00	
Amount Uncompleted				\$140,000.00	
Subcontractor					
Type of Work		Tree Care		Tree Care	
Subcontract Price		\$2,850.00		\$35,927.00	
Amount Uncompleted		\$0.00		\$0.00	
<b>Total Uncompleted</b>	<b>\$40,800.00</b>	<b>\$ 154,654.05</b>	<b>\$ 135,331.90</b>	<b>\$ 882,940.92</b>	<b>\$ 3,450,600.00</b>
<b>Totals</b>	<b>\$49,985.00</b>	<b>\$ 403,101.35</b>	<b>\$ 135,331.90</b>	<b>\$ 2,066,574.36</b>	<b>\$ 4,430,921.25</b>



Affidavit of Availability  
 For the Letting of 06/11/21

Instructions: Complete this form by either typing or using black ink. "Authorization to Bid" will not be issued unless both sides of this form are completed in detail. Use additional forms as needed to list all work.

**Part I. Work Under Contract**

List below all work you have under contract as either a prime contractor or a subcontractor. It is required to include all pending low bids not yet awarded or rejected. In a joint venture, list only that portion of the work which is the responsibility of your company. The uncompleted dollar value is to be based upon the most recent engineer's or owners estimate, and must include work subcontracted to others. If no work is contracted, show NONE

	16	17	18	19	20	
Contract Number						
Contract With	Winnetka	Deerfield	Niles	Schaumburg	Winnetka	
Estimated Completion Date		55 Working Days	8/1/2021	10/29/2021		
Total Contract Price	\$ 1,274,734.71	\$ 1,958,824.17	\$ 104,562.00	\$ 1,117,285.80	\$ 3,533,333.29	Accumulated Totals
Uncompleted Dollar Value if Firm is the Prime Contractor	\$ 286,781.37	\$ 990,864.50	\$ 104,562.00	\$ -	\$ 1,615,528.74	\$ 2,997,736.61
Uncompleted Dollar Value if Firm is the Subcontractor						\$ -
<b>Total Value of All Work</b>						<b>\$ 2,997,736.61</b>

**Part II. Awards Pending and Uncompleted Work to be done with your own forces.**

List below the uncompleted dollar value of work for each contract and awards pending to be completed with your own forces. All work subcontracted to others will be listed on the reverse of this form. In a joint venture, list only that portion of the work to be done by your company. If no work is contracted, show NONE

						Accumulated Totals
Earthwork	\$5,000.00	\$150,000.00	\$6,328.00	\$187,086.60	\$130,000.00	\$ 478,414.60
Portland Cement Concrete Paving	\$ -				\$0.00	\$ -
HMA Plant Mix						\$ -
HMA Paving	\$43,996.22	\$40,000.00	\$12,325.00	\$184,834.31	\$400,000.00	\$ 681,155.53
Clean & Seal Cracks/ Joints						\$ -
Aggregate Bases & Surfaces		\$40,000.00	\$1,175.00	\$62,887.35		\$ 104,062.35
Highway, R.R. & Water Structures						\$ -
Drainage	\$2,500.00	\$170,000.00	\$22,480.00	\$110,446.00	\$750,000.00	\$ 1,055,426.00
Electrical						\$ -
Cover and Seal Coats						\$ -
Concrete Construction	\$20,000.00	\$150,000.00	\$27,984.00	\$157,713.90	\$200,000.00	\$ 555,697.90
Landscaping		\$43,668.00	\$510.00	\$0.00	\$25,000.00	\$ 69,178.00
Fencing						\$ -
Guardrail						\$ -
Painting						\$ -
Signing	\$17,700.00		\$1,840.00	\$2,145.00		\$ 21,685.00
Cold Milling, Planning & Rotomilling		\$6,901.50			\$37,705.50	\$ 44,607.00
Demolition						\$ -
Pavement Markings (Paint)						\$ -
Other Construction (List)	\$15,000.00	\$40,000.00	\$18,001.50	\$129,739.52	\$40,000.00	\$ 242,741.02
						\$ -
<b>Totals</b>	<b>\$ 104,196.22</b>	<b>\$ 640,569.50</b>	<b>\$ 90,643.50</b>	<b>\$ 834,852.68</b>	<b>\$ 1,582,705.50</b>	<b>\$ 3,252,967.40</b>

Disclosure of this information is REQUIRED to accomplish the statutory purpose as outlined in the "Illinois Procurement Code." Failure to comply will result in non-issuance of an "Authorization to Bid." This form has been approved by the State Forms Management Center.

**Part III. Work Subcontracted to Others**

For each contract described in Part I, list all the work you have subcontracted to others.

	16	17	18	19	20
Subcontractor					
Type of Work	Brick Paving	HMA Paving	Electrical	Electrical	Electrical
Subcontract Price	\$131,138.00	\$329,435.00	\$10,000.00	\$198,313.22	\$2,825.00
Amount Uncompleted	\$40,000.00	\$329,435.00	\$10,000.00	\$198,313.22	\$2,825.00
Subcontractor					
Type of Work	Electrical	Directional Drilling	Pavement Marking	Irrigation	Pavement Marking
Subcontract Price	\$361,173.59	\$66,640.00	\$3,918.50	\$17,095.00	\$29,998.24
Amount Uncompleted	\$120,000.00	\$0.00	\$3,918.50	\$17,095.00	\$29,998.24
Subcontractor					
Type of Work	Landscaping	Electrical		Landscaping	
Subcontract Price	\$20,917.00	\$18,860.00		\$35,557.70	
Amount Uncompleted	\$20,917.00	\$18,860.00		\$35,557.70	
Subcontractor					
Type of Work	Pavement Marking	Environmental		Layout	
Subcontract Price	\$1,668.15	\$4,200.00		\$9,000.00	
Amount Uncompleted	\$1,668.15	\$2,000.00		\$9,000.00	
Subcontractor					
Type of Work	Tree Care			LJS	
Subcontract Price	\$3,552.00			\$13,546.40	
Amount Uncompleted	\$0.00			\$13,546.40	
Subcontractor					
Type of Work				Pavement Marking	
Subcontract Price				\$6,245.80	
Amount Uncompleted				\$6,245.80	
Subcontractor					
Type of Work				Tree Care	
Subcontract Price				\$2,675.00	
Amount Uncompleted			\$ -	\$2,675.00	
Subcontractor					
Type of Work					
Subcontract Price					
Amount Uncompleted					\$ -
<b>Total Uncompleted</b>	<b>\$ 182,585.15</b>	<b>\$ 350,295.00</b>	<b>\$ 13,918.50</b>	<b>\$ 282,433.12</b>	<b>\$ 32,823.24</b>
<b>Totals</b>	<b>\$ 518,448.74</b>	<b>\$ 419,135.00</b>	<b>\$ 13,918.50</b>	<b>\$ 282,433.12</b>	<b>\$ 32,823.24</b>



Affidavit of Availability  
For the Letting of 06/11/21

Instructions: Complete this form by either typing or using black ink. "Authorization to Bid" will not be issued unless both sides of this form are completed in detail. Use additional forms as needed to list all work.

**Part I. Work Under Contract**

List below all work you have under contract as either a prime contractor or a subcontractor. It is required to include all pending low bids not yet awarded or rejected. In a joint venture, list only that portion of the work which is the responsibility of your company. The uncompleted dollar value is to be based upon the most recent engineer's or owners estimate, and must include work subcontracted to others. If no work is contracted, show NONE

	21	22	23	24	25	
Contract Number					61G57	
Contract With	Fox Lake	Elk Grove Village	IDOT	Schaumburg	IDOT	
Estimated Completion Date	90 Calendar Days	9/30/2020	70 Working Days	10/29/2021	110 Working Days	
Total Contract Price	\$ 517,952.00	\$ 794,935.98	\$ 2,498,941.39	\$ 1,117,285.80	\$ 2,386,230.07	Accumulated Totals
Uncompleted Dollar Value if Firm is the Prime Contractor	\$ 517,952.00	\$ -	\$ 2,365,623.34	\$ 1,117,285.80	\$ 2,249,110.87	\$ 6,249,972.01
Uncompleted Dollar Value if Firm Is the Subcontractor						\$ -
Total Value of All Work						\$ 6,249,972.01

**Part II. Awards Pending and Uncompleted Work to be done with your own forces.**

List below the uncompleted dollar value of work for each contract and awards pending to be completed with your own forces. All work subcontracted to others will be listed on the reverse of this form. In a joint venture, list only that portion of the work to be done by your company. If no work is contracted, show NONE

						Accumulated Totals
Earthwork	\$34,993.00		\$260,935.80	\$187,066.60	\$15,598.00	\$ 498,613.40
Portland Cement Concrete Paving						\$ -
HMA Plant Mix						\$ -
HMA Paving	\$69,900.00		\$307,001.44	\$184,834.31	\$48,298.09	\$ 610,033.84
Clean & Seal Cracks/ Joints						\$ -
Aggregate Bases & Surfaces	\$6,000.00	\$0.00	\$69,168.80	\$62,887.35	\$62,865.00	\$ 200,921.15
Highway,R.R. & Water Structures						\$ -
Drainage	\$24,950.00	\$0.00	\$733,619.00	\$110,446.00	\$177,229.00	\$ 1,046,244.00
Electrical						\$ -
Cover and Seal Coats						\$ -
Concrete Construction	\$166,975.00		\$261,849.25	\$157,713.90	\$828,866.00	\$ 1,415,404.15
Landscaping	\$23,234.00					\$ 23,234.00
Fencing						\$ -
Guardrail						\$ -
Painting						\$ -
Signing	\$1,800.00		\$2,485.00	\$2,145.00	\$33,380.00	\$ 39,810.00
Cold Milling, Planning & Rotomilling	\$7,200.00		\$20,591.30		\$4,944.00	\$ 32,735.30
Demolition						\$ -
Pavement Markings (Paint)						\$ -
Other Construction (List)	\$85,000.00		\$175,000.00	\$129,739.52	\$484,051.44	\$ 873,790.96
						\$ -
<b>Totals</b>	<b>\$ 420,052.00</b>	<b>\$ -</b>	<b>\$ 1,830,650.59</b>	<b>\$ 834,852.68</b>	<b>\$ 1,655,231.53</b>	<b>\$ 4,740,786.80</b>

Disclosure of this information is REQUIRED to accomplish the statutory purpose as outlined in the "Illinois Procurement Code." Failure to comply will result in non-issuance of an "Authorization to Bid." This form has been approved by the State Forms Management Center.

**Part III. Work Subcontracted to Others**

For each contract described in Part I, list all the work you have subcontracted to others.

	21	22	23	24	25
Subcontractor					
Type of Work	Electrical	Electrical	Electrical	Electrical	Electrical
Subcontract Price	\$89,910.00	\$221,860.45	\$382,349.40	\$198,313.22	\$200,712.16
Amount Uncompleted	\$89,910.00	\$0.00	\$382,349.40	\$198,313.22	\$200,712.16
Subcontractor					
Type of Work	Environmental	Layout	Fencing & Guardrail	Irrigation	Environmental
Subcontract Price	\$2,090.00	\$9,000.00	\$49,598.75	\$17,095.00	\$27,130.00
Amount Uncompleted	\$2,090.00	\$0.00	\$49,598.75	\$17,095.00	\$27,130.00
Subcontractor					
Type of Work	Layout	Pavement Marking	Landscaping	Landscaping	Fencing
Subcontract Price	\$5,000.00	\$10,850.70	\$48,223.65	\$35,557.70	\$88,404.00
Amount Uncompleted	\$5,000.00	\$0.00	\$48,223.65	\$35,557.70	\$88,404.00
Subcontractor					
Type of Work	Tree Care	Stamped Asphalt	Layout	Layout	Landscaping
Subcontract Price	\$900.00	\$74,370.50	\$20,000.00	\$9,000.00	\$211,926.23
Amount Uncompleted	\$900.00	\$0.00	\$20,000.00	\$9,000.00	\$211,926.23
Subcontractor					
Type of Work		Tree Care	Pavement Marking	LJS	Layout
Subcontract Price		\$9,519.00	\$12,751.95	\$13,546.40	\$27,000.00
Amount Uncompleted		\$0.00	\$12,751.95	\$13,546.40	\$27,000.00
Subcontractor					
Type of Work			Envrionmental	Pavement Marking	Pavement Marking
Subcontract Price			\$12,705.00	\$6,245.80	\$20,070.45
Amount Uncompleted			\$12,705.00	\$6,245.80	\$20,070.45
Subcontractor					
Type of Work			Tree Care	Tree Care	Site Video
Subcontract Price			\$9,344.00	\$2,675.00	\$5,000.00
Amount Uncompleted			\$9,344.00	\$2,675.00	\$5,000.00
Subcontractor					
Type of Work					Tree Care
Subcontract Price					\$13,636.50
Amount Uncompleted					\$13,636.50
Subcontractor					
Type of Work					
Subcontract Price					
Amount Uncompleted					
<b>Total Uncompleted</b>	<b>\$ 97,900.00</b>	<b>\$ -</b>	<b>\$ 534,972.75</b>	<b>\$ 282,433.12</b>	<b>\$ 593,879.34</b>
<b>Totals</b>	<b>\$ 97,900.00</b>	<b>\$ 325,600.65</b>	<b>\$ 534,972.75</b>	<b>\$ 282,433.12</b>	<b>\$ 593,879.34</b>



Affidavit of Availability  
For the Letting of 06/11/21

Instructions: Complete this form by either typing or using black ink. "Authorization to Bid" will not be issued unless both sides of this form are completed in detail. Use additional forms as needed to list all work.

**Part I. Work Under Contract**

List below all work you have under contract as either a prime contractor or a subcontractor. It is required to include all pending low bids not yet awarded or rejected. In a joint venture, list only that portion of the work which is the responsibility of your company. The uncompleted dollar value is to be based upon the most recent engineer's or owners estimate, and must include work subcontracted to others. If no work is contracted, show NONE

	26	27	28	29	30	
Contract Number						
Contract With	Northlake	Mt. Prospect	Stone Park	IDOT	Winnetka	
Estimated Completion Date	10/15/2021	90 Calendar Days	30 Working Days	55 Working Days	7/25/2021	
Total Contract Price	\$ 3,584,685.75	\$ 1,247,863.20	\$ 94,680.65	\$ 574,435.29	\$ 354,077.69	Accumulated Totals
Uncompleted Dollar Value if Firm is the Prime Contractor	\$ 1,092,807.50	\$ 1,247,863.20	\$ 1,000.00	\$ 522,261.79	\$ 156,287.94	\$ 3,020,220.43
Uncompleted Dollar Value if Firm is the Subcontractor						\$ -
<b>Total Value of All Work</b>						<b>\$ 3,020,220.43</b>

**Part II. Awards Pending and Uncompleted Work to be done with your own forces.**

List below the uncompleted dollar value of work for each contract and awards pending to be completed with your own forces. All work subcontracted to others will be listed on the reverse of this form. In a joint venture, list only that portion of the work to be done by your company. If no work is contracted, show NONE

						Accumulated Totals
Earthwork	\$30,000.00	\$340.00		\$39,255.00	\$6,000.00	\$ 75,595.00
Portland Cement Concrete Paving						\$ -
HMA Plant Mix						\$ -
HMA Paving	\$400,000.00	\$198,364.80		\$37,767.29	\$124,977.04	\$ 761,109.13
Clean & Seal Cracks/ Joints		\$0.00				\$ -
Aggregate Bases & Surfaces	\$10,000.00			\$12,376.00	\$520.00	\$ 22,896.00
Highway, R.R. & Water Structures						\$ -
Drainage	\$240,000.00	\$793,530.00		\$5,000.00	\$3,500.00	\$ 1,042,030.00
Electrical						\$ -
Cover and Seal Coats						\$ -
Concrete Construction	\$110,000.00	\$41,870.00		\$119,124.00	\$5,000.00	\$ 275,994.00
Landscaping	\$3,700.00	\$50,000.00	\$0.00		\$7,233.00	\$ 60,933.00
Fencing						\$ -
Guardrail						\$ -
Painting						\$ -
Signing				\$6,917.00		\$ 6,917.00
Cold Milling, Planning & Rotomilling	\$40,000.00	\$71,395.00		\$10,686.50		\$ 122,081.50
Demolition						\$ -
Pavement Markings (Paint)						\$ -
Other Construction (List)	\$50,000.00	\$80,000.00	\$1,000.00	\$55,000.00	\$5,000.00	\$ 191,000.00
						\$ -
<b>Totals</b>	<b>\$ 883,700.00</b>	<b>\$ 1,235,499.80</b>	<b>\$ 1,000.00</b>	<b>\$ 286,125.79</b>	<b>\$ 152,230.04</b>	<b>\$ 2,558,555.63</b>

Disclosure of this information is REQUIRED to accomplish the statutory purpose as outlined in the "Illinois Procurement Code." Failure to comply will result in non-issuance of an "Authorization to Bid." This form has been approved by the State Forms Management Center.

## Part III. Work Subcontracted to Others

For each contract described in Part I, list all the work you have subcontracted to others.

	26	27	28	29	30
Subcontractor					
Type of Work	ARCCT	Directional Boring		Brick Paving	Pavement Marking
Subcontract Price	\$25,025.00	\$7,200.00		\$30,693.00	\$4,057.90
Amount Uncompleted	\$25,025.00	\$7,200.00		\$30,693.00	\$4,057.90
Subcontractor					
Type of Work	CIPP	Pavement Marking		Electrical	
Subcontract Price	\$804,170.00	\$5,163.40		\$75,095.00	
Amount Uncompleted	\$100,000.00	\$5,163.40		\$75,095.00	
Subcontractor					
Type of Work	Electrical			Irrigation	
Subcontract Price	\$86,170.25			\$35,500.00	
Amount Uncompleted	\$60,000.00			\$35,500.00	
Subcontractor					
Type of Work	Fencing			Landscaping	
Subcontract Price	\$2,250.00			\$56,481.00	
Amount Uncompleted	\$2,250.00			\$56,481.00	
Subcontractor					
Type of Work	Layout			Layout	
Subcontract Price	\$12,000.00			\$7,000.00	
Amount Uncompleted	\$2,000.00			\$7,000.00	
Subcontractor					
Type of Work	Line Stops			Pavement Marking	
Subcontract Price	\$5,600.00			\$7,237.00	
Amount Uncompleted	\$0.00			\$7,237.00	
Subcontractor					
Type of Work	Pavement Marking			Envrionmental	
Subcontract Price	\$8,945.50			\$12,190.00	
Amount Uncompleted	\$8,945.50			\$12,190.00	
Subcontractor					
Type of Work	Smoke Testing			Asphalt Stamping	
Subcontract Price	\$10,887.00			\$11,940.00	
Amount Uncompleted	\$10,887.00			\$11,940.00	
<b>Total Uncompleted</b>	<b>\$ 209,107.50</b>	<b>\$ 12,363.40</b>	<b>\$ -</b>	<b>\$ 236,136.00</b>	<b>\$ 4,057.90</b>
<b>Totals</b>	<b>\$ 955,047.75</b>	<b>\$ 12,363.40</b>	<b>\$ -</b>	<b>\$ 236,136.00</b>	<b>\$ 4,057.90</b>



Affidavit of Availability  
 For the Letting of 06/11/21

Instructions: Complete this form by either typing or using black ink. "Authorization to Bid" will not be issued unless both sides of this form are completed in detail. Use additional forms as needed to list all work.

**Part I. Work Under Contract**

List below all work you have under contract as either a prime contractor or a subcontractor. It is required to include all pending low bids not yet awarded or rejected. In a joint venture, list only that portion of the work which is the responsibility of your company. The uncompleted dollar value is to be based upon the most recent engineer's or owners estimate, and must include work subcontracted to others. If no work is contracted, show NONE

	31	32	33	34	35	
Contract Number		61G09				
Contract With	Willmette	IDOT	Niles	Villa Park	York Township	
Estimated Completion Date	9/17/2021	60 Working Days	11/5/2021	180 Calendar Days	7/1/2022	
Total Contract Price	\$ 1,894,282.40	\$ 1,304,037.15	\$ 1,675,346.05	\$ 3,054,459.02	\$ 3,959,337.48	Accumulated Totals
Uncompleted Dollar Value if Firm is the Prime Contractor	\$ 1,894,282.40	\$ 1,253,557.42	\$ 1,675,346.05	\$ 3,054,459.02	\$ 3,959,337.48	\$ 11,836,982.37
Uncompleted Dollar Value if Firm is the Subcontractor						\$ -
<b>Total Value of All Work</b>						<b>\$ 11,836,982.37</b>

**Part II. Awards Pending and Uncompleted Work to be done with your own forces.**

List below the uncompleted dollar value of work for each contract and awards pending to be completed with your own forces. All work subcontracted to others will be listed on the reverse of this form. In a joint venture, list only that portion of the work to be done by your company. If no work is contracted, show NONE

						Accumulated Totals
Earthwork	\$128,685.85	\$21,226.00	\$118,856.00	\$61,083.00	\$305,411.70	\$ 635,262.55
Portland Cement Concrete Paving			\$181,288.00			\$ 181,288.00
HMA Plant Mix						\$ -
HMA Paving	\$98,902.50	\$677,430.15	\$486,534.10	\$357,136.37	\$581,305.00	\$ 2,201,308.12
Clean & Seal Cracks/ Joints					\$27,401.00	\$ 27,401.00
Aggregate Bases & Surfaces	\$22,472.00		\$14,669.70	\$6,628.60	\$7,964.00	\$ 51,734.30
Highway,R.R.& Water Structures						\$ -
Drainage	\$234,682.50		\$163,940.00		\$1,204,819.00	\$ 1,603,441.50
Electrical						\$ -
Cover and Seal Coats						\$ -
Concrete Construction	\$645,880.50	\$263,305.00	\$398,670.50	\$533,589.40	\$715,174.68	\$ 2,556,620.08
Landscaping	\$46,212.00		\$23,135.75	\$105,691.35	\$277,938.30	\$ 452,977.40
Fencing						\$ -
Guardrail						\$ -
Painting						\$ -
Signing			\$4,621.50	\$8,200.00		\$ 12,821.50
Cold Milling, Planning & Rotomilling	\$110,807.55	\$102,841.92	\$135,657.50	\$145,112.50	\$68,117.50	\$ 582,536.97
Demolition						\$ -
Pavement Markings (Paint)						\$ -
Other Construction (List)	\$107,111.00	\$60,000.00	\$114,080.00	\$274,000.00	\$509,000.00	\$ 1,064,191.00
						\$ -
<b>Totals</b>	<b>\$ 1,394,753.90</b>	<b>\$ 1,124,803.07</b>	<b>\$ 1,641,453.05</b>	<b>\$ 1,491,441.22</b>	<b>\$ 3,697,131.18</b>	<b>\$ 9,349,582.42</b>

Disclosure of this information is REQUIRED to accomplish the statutory purpose as outlined in the "Illinois Procurement Code." Failure to comply will result in non-issuance of an "Authorization to Bid." This form has been approved by the State Forms Management Center.

**Part III. Work Subcontracted to Others**

For each contract described in Part I, list all the work you have subcontracted to others.

	31	32	33	34	35
Subcontractor					
Type of Work	Brick Paving	Electrical	Irrigation	Pavement Marking	Brick Paving
Subcontract Price	\$116,022.70	\$7,084.00	\$2,310.00	\$6,762.80	\$81,780.00
Amount Uncompleted	\$116,022.70	\$7,084.00	\$2,310.00	\$6,762.80	\$81,780.00
Subcontractor					
Type of Work	Electrical	Landscaping	Layout	Sewer & Water	Guardrail
Subcontract Price	\$9,025.00	\$9,506.45	\$21,400.00	\$1,546,350.00	\$21,709.00
Amount Uncompleted	\$9,025.00	\$9,506.45	\$21,400.00	\$1,546,350.00	\$21,709.00
Subcontractor					
Type of Work	Irrigation	Layout	Pavement Marking	Site Video	LJS
Subcontract Price	\$14,830.00	\$12,800.00	\$8,833.00	\$2,500.00	\$28,200.00
Amount Uncompleted	\$14,830.00	\$10,000.00	\$8,833.00	\$2,500.00	\$28,200.00
Subcontractor					
Type of Work	Layout	Pavement Marking	Tree Care	Tree Care	Pavement Marking
Subcontract Price	\$7,500.00	\$26,123.90	\$1,350.00	\$7,405.00	\$3,312.00
Amount Uncompleted	\$7,500.00	\$26,123.90	\$1,350.00	\$7,405.00	\$3,312.00
Subcontractor					
Type of Work	Pavement Marking	Sewer			Retaining Wall
Subcontract Price	\$9,661.10	\$56,040.00			\$95,000.00
Amount Uncompleted	\$9,661.10	\$56,040.00			\$95,000.00
Subcontractor					
Type of Work	Tree Care	Traffic Control			SRCT
Subcontract Price	\$10,340.00	\$33,750.00			\$20,675.30
Amount Uncompleted	\$10,340.00	\$20,000.00			\$20,675.30
Subcontractor					
Type of Work	HMA Paving				Tree Care
Subcontract Price	\$ 332,149.70				\$11,530.00
Amount Uncompleted	\$ 332,149.70				\$11,530.00
Subcontractor					
Type of Work					
Subcontract Price					
Amount Uncompleted					
<b>Total Uncompleted</b>	<b>\$ 499,528.50</b>	<b>\$ 128,754.35</b>	<b>\$ 33,893.00</b>	<b>\$ 1,563,017.80</b>	<b>\$ 262,206.30</b>
<b>Totals</b>	<b>\$ 499,528.50</b>	<b>\$ 145,304.35</b>	<b>\$ 33,893.00</b>	<b>\$ 1,563,017.80</b>	<b>\$ 262,206.30</b>



Affidavit of Availability  
 For the Letting of 06/11/21

Instructions: Complete this form by either typing or using black ink. "Authorization to Bid" will not be issued unless both sides of this form are completed in detail. Use additional forms as needed to list all work.

**Part I. Work Under Contract**

List below all work you have under contract as either a prime contractor or a subcontractor. It is required to include all pending low bids not yet awarded or rejected. In a joint venture, list only that portion of the work which is the responsibility of your company. The uncompleted dollar value is to be based upon the most recent engineer's or owners estimate, and must include work subcontracted to others. If no work is contracted, show NONE

	36	37	38	39	40	
Contract Number						
Contract With	Hoffman Estates	Western Springs				
Estimated Completion Date	30 Working Days	105 Working Days				
Total Contract Price	\$359,365.87	\$ 1,657,345.16				Accumulated Totals
Uncompleted Dollar Value if Firm is the Prime Contractor	\$ 86,898.50	\$ 1,657,345.16	\$ -	\$ -	\$ -	\$ 1,744,243.66
Uncompleted Dollar Value if Firm is the Subcontractor					\$ -	\$ -
<b>Total Value of All Work</b>						<b>\$ 1,744,243.66</b>

**Part II. Awards Pending and Uncompleted Work to be done with your own forces.**

List below the uncompleted dollar value of work for each contract and awards pending to be completed with your own forces. All work subcontracted to others will be listed on the reverse of this form. In a joint venture, list only that portion of the work to be done by your company. If no work is contracted, show NONE

					Accumulated Totals
Earthwork	\$7,500.00	\$205,829.20			\$ 213,329.20
Portland Cement Concrete Paving	\$0.00	\$351,540.00			\$ 351,540.00
HMA Plant Mix					\$ -
HMA Paving	\$14,640.00	\$7,945.00			\$ 22,585.00
Clean & Seal Cracks/ Joints					\$ -
Aggregate Bases & Surfaces	\$6,044.50	\$132,584.50			\$ 138,629.00
Highway,R.R.& Water Structures					\$ -
Drainage	\$5,000.00	\$528,268.00			\$ 533,268.00
Electrical					\$ -
Cover and Seal Coats					\$ -
Concrete Construction	\$25,649.00	\$152,258.65			\$ 177,907.65
Landscaping	\$10,482.00	\$84,184.61			\$ 94,666.61
Fencing					\$ -
Guardrail					\$ -
Painting					\$ -
Signing	\$1,800.00				\$ 1,800.00
Cold Milling, Planning & Rotomilling	\$0.00	\$ -			\$ -
Demolition					\$ -
Pavement Markings (Paint)					\$ -
Other Construction (List)	\$7,500.00	\$170,475.00			\$ 177,975.00
					\$ -
<b>Totals</b>	<b>\$ 78,615.50</b>	<b>\$ 1,633,084.96</b>	<b>\$ -</b>	<b>\$ -</b>	<b>\$ 1,711,700.46</b>

Disclosure of this information is REQUIRED to accomplish the statutory purpose as outlined in the "Illinois Procurement Code." Failure to comply will result in non-issuance of an "Authorization to Bid." This form has been approved by the State Forms Management Center.

**Part III. Work Subcontracted to Others**

For each contract described in Part I, list all the work you have subcontracted to others.

	36	37	38	39	40
Subcontractor					
Type of Work	Pavement Marking	Layout			
Subcontract Price	\$6,783.00	\$18,365.00			
Amount Uncompleted	\$6,783.00	\$18,365.00			
Subcontractor					
Type of Work	Tree Care	Pavement Marking			
Subcontract Price	\$1,500.00	\$3,895.20			
Amount Uncompleted	\$1,500.00	\$3,895.20			
Subcontractor					
Type of Work		Site Video			
Subcontract Price		\$2,000.00			
Amount Uncompleted		\$2,000.00			
Subcontractor					
Type of Work					
Subcontract Price					
Amount Uncompleted					
Subcontractor					
Type of Work					
Subcontract Price					
Amount Uncompleted					
Subcontractor					
Type of Work					
Subcontract Price					
Amount Uncompleted					
Subcontractor					
Type of Work					
Subcontract Price					
Amount Uncompleted					
Subcontractor					
Type of Work					
Subcontract Price					
Amount Uncompleted					
<b>Total Uncompleted</b>	<b>\$ 8,283.00</b>	<b>\$ 24,260.20</b>	<b>\$ -</b>	<b>\$ -</b>	<b>\$ -</b>
<b>Totals</b>	<b>\$ 8,283.00</b>	<b>\$ 24,260.20</b>	<b>\$ -</b>	<b>\$ -</b>	<b>\$ -</b>



Affidavit of Availability  
For the Letting of 06/11/21

Instructions: Complete this form by either typing or using black ink. "Authorization to Bid" will not be issued unless both sides of this form are completed in detail. Use additional forms as needed to list all work.

**Part I. Work Under Contract**

List below all work you have under contract as either a prime contractor or a subcontractor. It is required to include all pending low bids not yet awarded or rejected. In a joint venture, list only that portion of the work which is the responsibility of your company. The uncompleted dollar value is to be based upon the most recent engineer's or owners estimate, and must include work subcontracted to others. If no work is contracted, show **NONE**

	41	42	43	44	45	
Contract Number						
Contract With				Superior Overnight Services		
Estimated Completion Date				11/30/2020		
Total Contract Price				\$ 1,384,359.50		Accumulated Totals
Uncompleted Dollar Value if Firm is the Prime Contractor		\$ -	\$ -	\$ 1,000.00	\$ -	\$ 1,000.00
Uncompleted Dollar Value if Firm is the Subcontractor						\$ -
<b>Total Value of All Work</b>						<b>\$ 1,000.00</b>

**Part II. Awards Pending and Uncompleted Work to be done with your own forces.**

List below the uncompleted dollar value of work for each contract and awards pending to be completed with your own forces. All work subcontracted to others will be listed on the reverse of this form. In a joint venture, list only that portion of the work to be done by your company. If no work is contracted, show **NONE**

						Accumulated Totals
Earthwork						\$ -
Portland Cement Concrete Paving	\$0.00					\$ -
HMA Plant Mix						\$ -
HMA Paving				\$0.00		\$ -
Clean & Seal Cracks/ Joints						\$ -
Aggregate Bases & Surfaces	\$0.00					\$ -
Highway,R.R.& Water Structures						\$ -
Drainage						\$ -
Electrical						\$ -
Cover and Seal Coats						\$ -
Concrete Construction					\$0.00	\$ -
Landscaping						\$ -
Fencing						\$ -
Guardrail						\$ -
Painting						\$ -
Signing		\$ -				\$ -
Cold Milling, Planning & Rotomilling				\$0.00	\$0.00	\$ -
Demolition						\$ -
Pavement Markings (Paint)						\$ -
Other Construction (List)				\$1,000.00		\$ 1,000.00
						\$ -
<b>Totals</b>	<b>\$ -</b>	<b>\$ -</b>	<b>\$ -</b>	<b>\$ 1,000.00</b>	<b>\$ -</b>	<b>\$ 1,000.00</b>

Disclosure of this information is **REQUIRED** to accomplish the statutory purpose as outlined in the "Illinois Procurement Code." Failure to comply will result in non-issuance of an "Authorization to Bid." This form has been approved by the State Forms Management Center.

**Part III. Work Subcontracted to Others**

For each contract described in Part I, list all the work you have subcontracted to others.

	41	42	43	44	45
Subcontractor					
Type of Work				Electrical	
Subcontract Price				\$94,000.00	
Amount Uncompleted				\$0.00	
Subcontractor					
Type of Work				Fencing	
Subcontract Price				\$61,500.00	
Amount Uncompleted				\$0.00	
Subcontractor					
Type of Work				Layout	
Subcontract Price				\$9,500.00	
Amount Uncompleted				\$0.00	
Subcontractor					
Type of Work				Pavement Marking	
Subcontract Price				\$3,500.00	
Amount Uncompleted				\$0.00	
Subcontractor					
Type of Work				Tree Care	
Subcontract Price				\$13,206.00	
Amount Uncompleted				\$0.00	
Subcontractor					
Type of Work					
Subcontract Price					
Amount Uncompleted					
Subcontractor					
Type of Work					
Subcontract Price					
Amount Uncompleted					
Subcontractor					
Type of Work					
Subcontract Price					
Amount Uncompleted					
Subcontractor					
Type of Work					
Subcontract Price					
Amount Uncompleted					
<b>Total Uncompleted</b>	<b>\$ -</b>	<b>\$ -</b>	<b>\$ -</b>	<b>\$ -</b>	<b>\$ -</b>
<b>Totals</b>	<b>\$ -</b>	<b>\$ -</b>	<b>\$ -</b>	<b>\$ 181,706.00</b>	<b>\$ -</b>



**Illinois Department of Transportation**  
 Bureau of Construction  
 2300 South Dakota Parkway/Room 322  
 Springfield, Illinois 62761

Affidavit of Availability  
 For the Letting of 06/11/21

Instructions: Complete this form by either typing or using black ink. "Authorization to Bid" will not be issued unless both sides of this form are completed in detail. Use additional forms as needed to list all work.

**Part I. Work Under Contract**

List below all work you have under contract as either a prime contractor or a subcontractor. It is required to include all pending low bids not yet awarded or rejected. In a joint venture, list only that portion of the work which is the responsibility of your company. The uncompleted dollar value is to be based upon the most recent engineer's or owners estimate, and must include work subcontracted to others. If no work is contracted, show NONE

	46	47	48	49	50	
Contract Number						
Contract With						
Estimated Completion Date						
Total Contract Price						Accumulated Totals
Uncompleted Dollar Value if Firm is the Prime Contractor	\$ -	\$ -		\$ -	\$ -	\$ -
Uncompleted Dollar Value if Firm is the Subcontractor			\$ -	\$ -	\$ -	\$ -
<b>Total Value of All Work</b>						<b>\$ -</b>

**Part II. Awards Pending and Uncompleted Work to be done with your own forces.**

List below the uncompleted dollar value of work for each contract and awards pending to be completed with your own forces. All work subcontracted to others will be listed on the reverse of this form. In a joint venture, list only that portion of the work to be done by your company. If no work is contracted, show NONE

						Accumulated Totals
Earthwork	\$0.00	\$0.00				\$ -
Portland Cement Concrete Paving		\$0.00			\$ -	\$ -
HMA Plant Mix					\$ -	\$ -
HMA Paving	\$0.00	\$0.00				\$ -
Clean & Seal Cracks/ Joints					\$0.00	\$ -
Aggregate Bases & Surfaces	\$ -	\$0.00			\$0.00	\$ -
Highway,R.R.& Water Structures						\$ -
Drainage	\$0.00	\$0.00			\$0.00	\$ -
Electrical						\$ -
Cover and Seal Coats						\$ -
Concrete Construction	\$0.00	\$0.00				\$ -
Landscaping	\$0.00	\$0.00				\$ -
Fencing						\$ -
Guardrail						\$ -
Painting						\$ -
Signing		\$ -				\$ -
Cold Milling, Planning & Rotomilling		\$0.00			\$0.00	\$ -
Demolition						\$ -
Pavement Markings (Paint)						\$ -
Other Construction (List)		\$0.00				\$ -
						\$ -
<b>Totals</b>	<b>\$ -</b>	<b>\$ -</b>	<b>\$ -</b>	<b>\$ -</b>	<b>\$ -</b>	<b>\$ -</b>

Disclosure of this information is **REQUIRED** to accomplish the statutory purpose as outlined in the "Illinois Procurement Code." Failure to comply will result in non-issuance of an "Authorization to Bid." This form has been approved by the State Forms Management Center.

**Part III. Work Subcontracted to Others**

For each contract described in Part I, list all the work you have subcontracted to others.

	46	47	48	49	50	
Subcontractor						
Type of Work						
Subcontract Price						
Amount Uncompleted						
Subcontractor						
Type of Work						
Subcontract Price						
Amount Uncompleted						
Subcontractor						
Type of Work						
Subcontract Price						
Amount Uncompleted						
Subcontractor						
Type of Work						
Subcontract Price						
Amount Uncompleted						
Subcontractor						
Type of Work						
Subcontract Price						
Amount Uncompleted						
Subcontractor						
Type of Work						
Subcontract Price						
Amount Uncompleted						
Subcontractor						
Type of Work						
Subcontract Price						
Amount Uncompleted						
Subcontractor						
Type of Work						
Subcontract Price						
Amount Uncompleted						
Subcontractor						
Type of Work						
Subcontract Price						
Amount Uncompleted						
Subcontractor						
Type of Work						
Subcontract Price						
Amount Uncompleted						
Subcontractor						
Type of Work						
Subcontract Price	\$	-				
Amount Uncompleted	\$	-	\$	-		
Total Uncompleted	\$	-	\$	-	\$	-
Totals	\$	-	\$	-	\$	-



Affidavit of Availability  
 For the Letting of 06/11/21

Instructions: Complete this form by either typing or using black ink. "Authorization to Bid" will not be issued unless both sides of this form are completed in detail. Use additional forms as needed to list all work.

**Part I. Work Under Contract**

List below all work you have under contract as either a prime contractor or a subcontractor. It is required to include all pending low bids not yet awarded or rejected. In a joint venture, list only that portion of the work which is the responsibility of your company. The uncompleted dollar value is to be based upon the most recent engineer's or owners estimate, and must include work subcontracted to others. If no work is contracted, show NONE

	51	52	53	54	55	
Contract Number						
Contract With						
Estimated Completion Date						
Total Contract Price						
Uncompleted Dollar Value If Firm is the Prime Contractor	\$ -	\$ -	\$ -	\$ -	\$ -	Accumulated Totals \$ -
Uncompleted Dollar Value if Firm is the Subcontractor		\$ -		\$ -	\$ -	\$ -
<b>Total Value of All Work</b>						<b>\$ -</b>

**Part II. Awards Pending and Uncompleted Work to be done with your own forces.**

List below the uncompleted dollar value of work for each contract and awards pending to be completed with your own forces. All work subcontracted to others will be listed on the reverse of this form. In a joint venture, list only that portion of the work to be done by your company. If no work is contracted, show NONE

						Accumulated Totals
Earthwork	\$0.00	\$0.00			\$0.00	\$ -
Portland Cement Concrete Paving		\$ -				\$ -
HMA Plant Mix						\$ -
HMA Paving	\$0.00	\$0.00			\$0.00	\$ -
Clean & Seal Cracks/ Joints						\$ -
Aggregate Bases & Surfaces	\$0.00	\$0.00	\$0.00	\$0.00	\$0.00	\$ -
Highway, R.R. & Water Structures						\$ -
Drainage	\$0.00	\$0.00	\$0.00		\$0.00	\$ -
Electrical						\$ -
Cover and Seal Coats						\$ -
Concrete Construction	\$0.00	\$0.00	\$0.00		\$0.00	\$ -
Landscaping	\$0.00	\$0.00			\$0.00	\$ -
Fencing						\$ -
Guardrail						\$ -
Painting						\$ -
Signing		\$0.00	\$ -		\$0.00	\$ -
Cold Milling, Planning & Rotomilling		\$0.00	\$0.00		\$ -	\$ -
Demolition						\$ -
Pavement Markings (Paint)						\$ -
Other Construction (List)	\$0.00	\$0.00			\$0.00	\$ -
						\$ -
<b>Totals</b>	<b>\$ -</b>	<b>\$ -</b>	<b>\$ -</b>	<b>\$ -</b>	<b>\$ -</b>	<b>\$ -</b>

Disclosure of this information is REQUIRED to accomplish the statutory purpose as outlined in the "Illinois Procurement Code." Failure to comply will result in non-issuance of an "Authorization to Bid." This form has been approved by the State Forms Management Center.

**Part III. Work Subcontracted to Others**

For each contract described in Part I, list all the work you have subcontracted to others.

	51	52	53	54	55
Subcontractor					
Type of Work					
Subcontract Price					
<b>Amount Uncompleted</b>					
Subcontractor					
Type of Work					
Subcontract Price					
<b>Amount Uncompleted</b>					
Subcontractor					
Type of Work					
Subcontract Price					
<b>Amount Uncompleted</b>					
Subcontractor					
Type of Work					
Subcontract Price					
<b>Amount Uncompleted</b>					
Subcontractor					
Type of Work					
Subcontract Price					
<b>Amount Uncompleted</b>					
Subcontractor					
Type of Work					
Subcontract Price					
<b>Amount Uncompleted</b>					
Subcontractor					
Type of Work					
Subcontract Price					
<b>Amount Uncompleted</b>					
Subcontractor					
Type of Work					
Subcontract Price					
<b>Amount Uncompleted</b>				\$ -	
<b>Total Uncompleted</b>	\$ -	\$ -	\$ -	\$ -	\$ -
<b>Totals</b>	\$ -	\$ -	\$ -	\$ -	\$ -



Affidavit of Availability  
For the Letting of 06/11/21

Instructions: Complete this form by either typing or using black ink. "Authorization to Bid" will not be issued unless both sides of this form are completed in detail. Use additional forms as needed to list all work.

**Part I. Work Under Contract**

List below all work you have under contract as either a prime contractor or a subcontractor. It is required to include all pending low bids not yet awarded or rejected. In a joint venture, list only that portion of the work which is the responsibility of your company. The uncompleted dollar value is to be based upon the most recent engineer's or owners estimate, and must include work subcontracted to others. If no work is contracted, show **NONE**

	56	57	58	59	60	
Contract Number						
Contract With						
Estimated Completion Date						
Total Contract Price						
Uncompleted Dollar Value if Firm is the Prime Contractor	\$ -	\$ -	\$ -	\$ -	\$ -	Accumulated Totals \$ -
Uncompleted Dollar Value if Firm is the Subcontractor						\$ -
<b>Total Value of All Work</b>						<b>\$ -</b>

**Part II. Awards Pending and Uncompleted Work to be done with your own forces.**

List below the uncompleted dollar value of work for each contract and awards pending to be completed with your own forces. All work subcontracted to others will be listed on the reverse of this form. In a joint venture, list only that portion of the work to be done by your company. If no work is contracted, show **NONE**

						Accumulated Totals
Earthwork	\$0.00	\$0.00		\$0.00	\$0.00	\$ -
Portland Cement Concrete Paving	\$ -		\$ -	\$ -	\$0.00	\$ -
HMA Plant Mix						\$ -
HMA Paving		\$0.00		\$0.00	\$ -	\$ -
Clean & Seal Cracks/ Joints						\$ -
Aggregate Bases & Surfaces	\$0.00	\$0.00		\$0.00	\$0.00	\$ -
Highway, R.R. & Water Structures						\$ -
Drainage	\$0.00	\$0.00	\$0.00	\$0.00	\$ -	\$ -
Electrical						\$ -
Cover and Seal Coats						\$ -
Concrete Construction	\$0.00	\$0.00		\$0.00	\$0.00	\$ -
Landscaping		\$0.00		\$0.00	\$ -	\$ -
Fencing		\$ -				\$ -
Guardrail						\$ -
Painting						\$ -
Signing		\$ -				\$ -
Cold Milling, Planning & Rotomilling	\$ -	\$0.00	\$ -	\$0.00	\$ -	\$ -
Demolition						\$ -
Pavement Markings (Paint)						\$ -
Other Construction (List)		\$0.00		\$0.00	\$0.00	\$ -
						\$ -
<b>Totals</b>	<b>\$ -</b>	<b>\$ -</b>	<b>\$ -</b>	<b>\$ -</b>	<b>\$ -</b>	<b>\$ -</b>

Disclosure of this information is **REQUIRED** to accomplish the statutory purpose as outlined in the "Illinois Procurement Code." Failure to comply will result in non-issuance of an "Authorization to Bid." This form has been approved by the State Forms Management Center.

**Part III. Work Subcontracted to Others**

For each contract described in Part I, list all the work you have subcontracted to others.

	56	57	58	59	60
Subcontractor					
Type of Work					
Subcontract Price					
<b>Amount Uncompleted</b>					
Subcontractor					
Type of Work					
Subcontract Price					
<b>Amount Uncompleted</b>					
Subcontractor					
Type of Work					
Subcontract Price					
<b>Amount Uncompleted</b>					
Subcontractor					
Type of Work					
Subcontract Price					
<b>Amount Uncompleted</b>					
Subcontractor					
Type of Work					
Subcontract Price					
<b>Amount Uncompleted</b>					
Subcontractor					
Type of Work					
Subcontract Price					
<b>Amount Uncompleted</b>					
Subcontractor					
Type of Work					
Subcontract Price					
<b>Amount Uncompleted</b>					
Subcontractor					
Type of Work					
Subcontract Price					
<b>Amount Uncompleted</b>					
Subcontractor					
Type of Work					
Subcontract Price					
<b>Amount Uncompleted</b>					
<b>Total Uncompleted</b>	\$ -	\$ -	\$ -	\$ -	\$ -
<b>Totals</b>	\$ -	\$ -	\$ -	\$ -	\$ -



**Illinois Department of Transportation**  
 Bureau of Construction  
 2300 South Dirksen Parkway/Room 322  
 Springfield, Illinois 62761

Affidavit of Availability  
 For the Letting of 06/11/21

Instructions: Complete this form by either typing or using black ink. "Authorization to Bid" will not be issued unless both sides of this form are completed in detail. Use additional forms as needed to list all work.

**Part I. Work Under Contract**

List below all work you have under contract as either a prime contractor or a subcontractor. It is required to include all pending low bids not yet awarded or rejected. In a joint venture, list only that portion of the work which is the responsibility of your company. The uncompleted dollar value is to be based upon the most recent engineer's or owners estimate, and must include work subcontracted to others. If no work is contracted, show NONE

	61	62	63	64	65	
Contract Number						
Contract With						
Estimated Completion Date						
Total Contract Price						Accumulated Totals
Uncompleted Dollar Value if Firm is the Prime Contractor	\$ -	\$ -	\$ -	\$ -	\$ -	\$ -
Uncompleted Dollar Value if Firm is the Subcontractor						\$ -
<b>Total Value of All Work</b>						<b>\$ -</b>

**Part II. Awards Pending and Uncompleted Work to be done with your own forces.**

List below the uncompleted dollar value of work for each contract and awards pending to be completed with your own forces. All work subcontracted to others will be listed on the reverse of this form. In a joint venture, list only that portion of the work to be done by your company. If no work is contracted, show NONE

						Accumulated Totals
Earthwork	\$0.00				\$0.00	\$ -
Portland Cement Concrete Paving						\$ -
HMA Plant Mix						\$ -
HMA Paving						\$ -
Clean & Seal Cracks/ Joints						\$ -
Aggregate Bases & Surfaces			\$0.00		\$0.00	\$ -
Highway, R.R. & Water Structures						\$ -
Drainage	\$0.00				\$0.00	\$ -
Electrical						\$ -
Cover and Seal Coats						\$ -
Concrete Construction			\$0.00		\$0.00	\$ -
Landscaping						\$ -
Fencing						\$ -
Guardrail						\$ -
Painting						\$ -
Signing						\$ -
Cold Milling, Planning & Rotomilling					\$0.00	\$ -
Demolition						\$ -
Pavement Markings (Paint)						\$ -
Other Construction (List)					\$0.00	\$ -
						\$ -
<b>Totals</b>	<b>\$ -</b>	<b>\$ -</b>	<b>\$ -</b>	<b>\$ -</b>	<b>\$ -</b>	<b>\$ -</b>

Disclosure of this information is **REQUIRED** to accomplish the statutory purpose as outlined in the "Illinois Procurement Code." Failure to comply will result in non-issuance of an "Authorization to Bid." This form has been approved by the State Forms Management Center.

**Part III. Work Subcontracted to Others**

For each contract described in Part I, list all the work you have subcontracted to others.

	61	62	63	64	65
Subcontractor					
Type of Work					
Subcontract Price					
<b>Amount Uncompleted</b>					
Subcontractor					
Type of Work					
Subcontract Price					
<b>Amount Uncompleted</b>					
Subcontractor					
Type of Work					
Subcontract Price					
<b>Amount Uncompleted</b>					
Subcontractor					
Type of Work					
Subcontract Price					
<b>Amount Uncompleted</b>					
Subcontractor					
Type of Work					
Subcontract Price					
<b>Amount Uncompleted</b>					
Subcontractor					
Type of Work					
Subcontract Price					
<b>Amount Uncompleted</b>					
Subcontractor					
Type of Work					
Subcontract Price					
<b>Amount Uncompleted</b>					
Subcontractor					
Type of Work					
Subcontract Price					
<b>Amount Uncompleted</b>					
Subcontractor					
Type of Work					
Subcontract Price					
<b>Amount Uncompleted</b>					
<b>Total Uncompleted</b>	\$ -	\$ -	\$ -	\$ -	\$ -
<b>Totals</b>	\$ -	\$ -	\$ -	\$ -	\$ -



**Illinois Department of Transportation**  
 Bureau of Construction  
 2300 South Dirksen Parkway/Room 302  
 Springfield, Illinois 62764

**SUMMARY SHEETS**

Affidavit of Availability  
 For the Letting of 06/11/21

**Instructions:** Complete this form by either typing or using black ink. "Authorization to Bid" will not be issued unless both sides of this form are completed in detail. Use additional forms as needed to list all work.

**Part I. Work Under Contract**

List below all work you have under contract as either a prime contractor or a subcontractor. It is required to include all pending low bids not yet awarded or rejected. In a joint venture, list only that portion of the work which is the responsibility of your company. The uncompleted dollar value is to be based upon the most recent engineer's or owners estimate, and must include work subcontracted to others. If no work is contracted, show **NONE**

Contract Number						
Contract With						
Estimated Completion Date						
Total Contract Price						<b>SUMMARY</b>
Uncompleted Dollar Value if Firm is the Prime Contractor						Accumulated Totals
Uncompleted Dollar Value if Firm is the Subcontractor						\$ 48,323,908.43
						\$ -
<b>Total Value of All Work</b>						<b>\$ 48,323,908.43</b>

**Part II. Awards Pending and Uncompleted Work to be done with your own forces.**

List below the uncompleted dollar value of work for each contract and awards pending to be completed with your own forces. All work subcontracted to others will be listed on the reverse of this form. In a joint venture, list only that portion of the work to be done by your company. If no work is contracted, show **NONE**

						Accumulated Totals
Earthwork						\$ 4,414,930.95
Portland Cement Concrete Paving						\$ 882,828.00
HMA Plant Mix						\$ -
HMA Paving						\$ 7,076,420.97
Clean & Seal Cracks/ Joints						\$ 27,401.00
Aggregate Bases & Surfaces						\$ 1,335,890.40
Highway,R.R.& Water Structures						\$ -
Drainage						\$ 6,674,948.60
Electrical						\$ -
Cover and Seal Coats						\$ -
Concrete Construction						\$ 8,056,527.03
Landscaping						\$ 1,135,869.66
Fencing						\$ 2,812.50
Guardrail						\$ -
Painting						\$ -
Signing						\$ 115,749.50
Cold Milling, Planning & Rotomilling						\$ 1,288,047.82
Demolition						\$ -
Pavement Markings (Paint)						\$ -
Other Construction (List)						\$ 4,537,008.11
<b>Totals</b>	\$ -	\$ -	\$ -	\$ -	\$ -	<b>\$ 35,548,434.44</b>

Disclosure of this information is **REQUIRED** to accomplish the statutory purpose as outlined in the "Illinois Procurement Code." Failure to comply will result in non-issuance of an "Authorization to Bid." This form has been approved by the State Forms Management Center.

**Part III. Work Subcontracted to Others**

For each contract described in Part I, list all the work you have subcontracted to others.

Subcontractor					
Type of Work					
Subcontract Price	\$ -	\$ -	\$ -	\$ -	\$ -
Amount Uncompleted	\$ -	\$ -	\$ -	\$ -	\$ -
Subcontractor					
Type of Work					
Subcontract Price	\$ -	\$ -	\$ -	\$ -	\$ -
Amount Uncompleted	\$ -	\$ -	\$ -	\$ -	\$ -
Subcontractor					
Type of Work					
Subcontract Price	\$ -	\$ -	\$ -	\$ -	\$ -
Amount Uncompleted	\$ -	\$ -	\$ -	\$ -	\$ -
Subcontractor					
Type of Work					
Subcontract Price	\$ -	\$ -	\$ -	\$ -	\$ -
Amount Uncompleted	\$ -	\$ -	\$ -	\$ -	\$ -
Subcontractor					
Type of Work					
Subcontract Price	\$ -	\$ -	\$ -	\$ -	\$ -
Amount Uncompleted	\$ -	\$ -	\$ -	\$ -	\$ -
Subcontractor					
Type of Work					
Subcontract Price	\$ -	\$ -	\$ -	\$ -	\$ -
Amount Uncompleted	\$ -	\$ -	\$ -	\$ -	\$ -
<b>Total Uncompleted</b>	\$ -	\$ -	\$ -	\$ -	\$ -
<b>SUMMARY TOTALS</b>	\$ -	\$ -	\$ -	\$ -	\$ 13,892,759.79

I, being duly sworn, do hereby declare that this affidavit is a true and correct statement relating to ALL uncompleted contracts of the undersigned for Federal, State, County, City and Private work, including ALL subcontract work, ALL pending low bids not yet awarded or rejected and ALL estimated completion dates.

Subscribed and sworn to before me

this 6th day of July, 2021

Kelly L Biello  
Notary Public

Type or Print Adele Lampignano President  
Officer or Director Title

Signed Adele Lampignano

My commission expires 11/16/2024

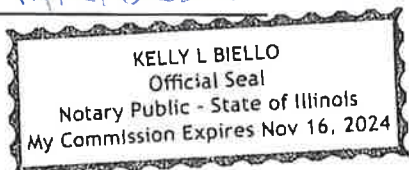

(Notary Seal)

Company A Lamp Concrete Contractors, Inc.

Address 1900 Wright Blvd.  
Schaumburg, Illinois 60193



RETURN WITH BID



Affidavit of Illinois Business Office

County DuPage
Local Public Agency Village of Villa Park
Section Number N/A
Route Charles Avenue

State of Illinois )
County of Cook ) ss.

I, Adele Lampignano of Schaumburg, Illinois,
(Name of Affiant) (City of Affiant) (State of Affiant)

being first duly sworn upon oath, states as follows:

- 1. That I am the President of A Lamp Concrete Contractors, Inc.
2. That I have personal knowledge of the facts herein stated.
3. That, if selected under this proposal, A Lamp Concrete Contractors, Inc. will maintain a business office in the State of Illinois which will be located in Cook County, Illinois.
4. That this business office will serve as the primary place of employment for any persons employed in the construction contemplated by this proposal.
5. That this Affidavit is given as a requirement of state law as provided in Section 30-22(8) of the Illinois Procurement Code.

Adele Lampignano (Signature)
Adele Lampignano, President (Print Name of Affiant)

This instrument was acknowledged before me on 6th day of July, 2021.

(SEAL)

Kelly L. Biello (Signature of Notary Public)

Printed 6/21/2021



BLR 12326 (01/08/14)





Apprenticeship or Training Program Certification

Return with Bid

Route Charles Avenue
County DuPage County
Local Agency Village of Villa Park
Section N/A

All contractors are required to complete the following certification:

- For this contract proposal or for all groups in this deliver and install proposal.
For the following deliver and install groups in this material proposal:

Blank lines for listing deliver and install groups.

Illinois Department of Transportation policy, adopted in accordance with the provisions of the Illinois Highway Code, requires this contract to be awarded to the lowest responsive and responsible bidder. The award decision is subject to approval by the Department. In addition to all other responsibility factors, this contract or deliver and install proposal requires all bidders and all bidders' subcontractors to disclose participation in apprenticeship or training programs that are (1) approved by and registered with the United States Department of Labor's Bureau of Apprenticeship and Training, and (2) applicable to the work of the above indicated proposals or groups. Therefore, all bidders are required to complete the following certification:

- I. Except as provided in paragraph IV below, the undersigned bidder certifies that it is a participant, either as an individual or as part of a group program, in an approved apprenticeship or training program applicable to each type of work or craft that the bidder will perform with its own employees.
II. The undersigned bidder further certifies for work to be performed by subcontract that each of its subcontractors submitted for approval either (A) is, at the time of such bid, participating in an approved, applicable apprenticeship or training program; or (B) will, prior to commencement of performance of work pursuant to this contract, establish participation in an approved apprenticeship or training program applicable to the work of the subcontract.
III. The undersigned bidder, by inclusion in the list in the space below, certifies the official name of each program sponsor holding the Certificate of Registration for all of the types of work or crafts in which the bidder is a participant and that will be performed with the bidder's employees. Types of work or craft that will be subcontracted shall be included and listed as subcontract work. The list shall also indicate any type of work or craft job category for which there is no applicable apprenticeship or training program available.

Laborers - 2, 68, 76 & 118
Operators -150

IV. Except for any work identified above, any bidder or subcontractor that shall perform all or part of the work of the contract or deliver and install proposal solely by individual owners, partners or members and not by employees to whom the payment of prevailing rates of wages would be required, check the following box, and identify the owner/operator workforce and positions of ownership.

\_\_\_\_\_  
\_\_\_\_\_  
\_\_\_\_\_  
\_\_\_\_\_

The requirements of this certification and disclosure are a material part of the contract, and the contractor shall require this certification provision to be included in all approved subcontracts. The bidder is responsible for making a complete report and shall make certain that each type of work or craft job category that will be utilized on the project is accounted for and listed. The Department at any time before or after award may require the production of a copy of each applicable Certificate of Registration issued by the United States Department of Labor evidencing such participation by the contractor and any or all of its subcontractors. In order to fulfill the participation requirement, it shall not be necessary that any applicable program sponsor be currently taking or that it will take applications for apprenticeship, training or employment during the performance of the work of this contract or deliver and install proposal.

Bidder: A Lamp Concrete Contractors, Inc.

By: *Adele Lampignano*  
(Signature) Adele Lampignano

Address: 1900 Wright Boulevard Schaumburg, IL 60193

Title: President

## INTERNATIONAL UNION OF OPERATING ENGINEERS

LOCAL UNION NO. 150, 150B, 150A, 150C, 150RA, 150D, 150G, 150M

AFFILIATED WITH THE A.F.L.-C.I.O. AND BUILDING TRADES DEPARTMENT

JAMES M. SWEENEY  
PRESIDENT-BUSINESS MANAGER



(708) 482-8800 · FAX (708) 482-7186  
6200 JOLIET ROAD  
COUNTRYSIDE, IL 60525-3992

January 25, 2016

A Lamp Concrete Contractors, Inc

Re: Proof of Compliance with 30 ILCS 500/30-22 (6)  
our File No. MI-00321

Dear Sir or Madam:

At the request of A Lamp Concrete Contractors Inc, I am providing you with evidence of the company's compliance with the apprenticeship requirements in 30 ILCS 500/30-22 (6) of the Illinois Procurement Code. I am submitting this letter along with apprenticeship certificates (Nos. IL012020003, IL008780173).

As a signatory contractor with the International Union of Operating Engineers, Local 150, AFL-CIO, A Lamp Concrete Contractors, Inc. is required by Collective Bargaining Agreement to participate in an applicable apprenticeship and training program approved by and registered with the United States Department of Labor's Bureau of Apprenticeship and Training. The attached certificates are evidence of compliance with the U.S. Department of Labor's apprenticeship requirements.

Thank you for your cooperation in this matter. If you have any questions or concerns, please do not hesitate to contact me.

Very truly yours,  
IUOE, Local 150, AFL-CIO  
District 1 dispatch office

  
Maribel Hernandez

mh

Enclosures: Certificates

**UNITED STATES DEPARTMENT OF LABOR**  
**Office of Apprenticeship Training, Employer and Labor Services**

**Bureau of Apprenticeship and Training**

**Certificate of Registration**

**Operating Engineers Local #150**

**Mainfield, Illinois**

**For the Trade of Operating Engineer**

**Registered as part of the National Apprenticeship Program**

**in accordance with the basic standards of apprenticeship**

**established by the Secretary of Labor**



November 5, 2002

Date

02 008780173

Registration No.

*L. L. Chao*

Secretary of Labor

*[Signature]*

Administrative Apprenticeship Training, Employer and Labor Services

# The United States Department of Labor

Office of Apprenticeship Training, Employer and Labor Services  
Bureau of Apprenticeship and Training

## Certificate of Registration

*Heavy Equipment Technician Operating Engineers Local #150  
Plainfield, Illinois*

*For the Trade of Repairer (Heavy)*

*Registered as part of the National Apprenticeship Program*

*in accordance with the basic standards of apprenticeship*

*established by the Secretary of Labor*

May 5, 2002  
Date

IL012020003  
Registration No.



*D. L. Chao*  
Secretary of Labor

*Anthony Savage*  
Administrator, Apprenticeship Training, Employer and Labor Services

**LiUNA!**  
 Chicagoland  
**LABORERS'**  
 District Council Training & Apprentices Fund

42-L

[chicagolaborers.org](http://chicagolaborers.org)

21 March 2019

**Executive Director**  
Thomas Nordeen

**Labor Trustees**  
James P. Connolly  
Martin Dwyer  
Martin Flanagan  
Joseph V. Healy  
Charles V. LoVerde III  
William Martin

**Management Trustees**  
Seth Gudeman  
Shane Higgins  
Joseph Koppers  
Robert G. Krug  
David Lorig  
William Vignocchi

**Carol Stream Location**  
1200 Old Gary Avenue  
Carol Stream IL 60188  
(630) 653-0006

**Chicago Location**  
5700 West Homer Street  
Chicago IL 60639  
(773) 413-3315

A Lamp Concrete Contractors, Inc.  
1900 Wright Boulevard  
Schaumburg, IL 60193

Dear Sue:

Enclosed you will please find a copy of the Department of Labor certification that you requested recently.

You may also use this letter as verification that A Lamp Concrete Contractors, Inc. is indeed signatory to the Chicago Laborers District Council, contributes to the Laborers Apprenticeship Fund and their active account is current and up to date.

Should you require anything further, please do not hesitate to contact me.

Yours very truly,

**Miranda Maddie**  
Office Manager



# The United States Department of Labor

Office of Apprenticeship Training, Employer and Labor Services  
Bureau of Apprenticeship and Training

## Certificate of Registration

*Chicagoland Laborers' J.A.T.C.  
Carol Stream, Illinois*

*For the Trade - Construction Craft Laborer*

*Registered as part of the National Apprenticeship Program  
in accordance with the basic standards of apprenticeship  
established by the Secretary of Labor*

April 12, 1999  
Date REVISED August 13, 2004  
IL 017990001  
Registration No.



*L. L. Chao*  
Secretary of Labor

*Anthony Swartz*  
Administrator, Apprenticeship Training, Employer and Labor Services



RETURN WITH BID

**ADDENDUM NO. 1  
ACKNOWLEDGMENT FORM**

I/We hereby acknowledge receipt of the following documents pertaining to **ADDENDUM No. 1** to the Bidding Documents for the Village of Villa Park's **Charles Avenue Improvements**.

Name: Kelly Biello

Title: Estimating Coordinator

Company: A Lamp Concrete

Signature: Kelly Biello

Date: 7/1/2021



## ADDENDUM NO. 1

DATE: July 1, 2021  
FROM: Village of Villa Park Public Works Department  
TO: All Plan Holders  
PROJECT: **Charles Avenue Improvements Project**

The Bidding Documents for the subject project are hereby amended as follows.

### 1. MODIFICATIONS

- a. Page 3 of 6 of BLR 12200, PROPOSAL, Item No. 8, REPLACE the last sentence with the following: "The amount of the check is ten (10) percent of the bid amount."
- b. Pages 1 through 5 of BLR 12200a, SCHEDULE OF PRICES, REPLACE pages 1 through 5 with the attached revised pages.
- c. Page 1 of BLR 12230, Local Agency Proposal Bid Bond, REPLACE the form with the attached revised form.
- d. Page 15 of the Special Provisions, DELETE the section COMPLETION DATE PLUS WORKING DAYS in its entirety.
- e. Page 15 of the Special Provisions, ADD the attached COMPLETION DATE PLUS CALENDAR DAYS Special Provision.
- f. Page 107 of the Special Provisions, PAY ITEM #120 – CONTINGENCY ALLOWANCE, paragraph C., REPLACE "\$30,000.00" with "\$50,000.00."
- g. Page 50 of the Special Provisions, PAY ITEM #60 – PVC PIPE DRAINS SDR 26 ASTM D-2241, 6", ADD the following to the second paragraph:

"Connections of the PVC pipe drains to RCP storm sewer pipe shall be made via mechanically coring a hole in the RCP pipe at the spring line, placing a Kor-N-Tee and Kor-N-Tee saddle around the RCP pipe, and inserting the PVC pipe into the tee in accordance with the manufacturer's directions. The connection, including mechanically coring, tee, saddle, labor, and equipment, shall be included in the cost of the PVC Pipe Drains."

- h. Page 97 of the Special Provisions, PAY ITEM #97, #98, & #99 – COMBINATION CONCRETE CURB AND GUTTER, TYPE B, before the **Basis of Payment**, ADD the following:

“Where proposed combination concrete curb and gutter is to be constructed abutting existing pavement, the existing pavement adjacent to the curb and gutter shall be saw cut with straight lines paralleling the curb and gutter when not on a radii. Regardless, the saw cut shall be a minimum of 6 inches wide from the existing edge of pavement. The existing pavement adjacent to the existing curb and gutter shall be removed. If the adjacent pavement is Portland cement concrete, #6 epoxy-coated tie bars shall be drilled and spaced 24 inches on center and vertically positioned in the center of the existing PCC pavement depth. The void between the proposed gutter flag and existing pavement shall be filled from the bottom of the subgrade to two inches below the edge of gutter with concrete meeting the specifications for concrete curb and gutter. This work of removing the existing pavement, drilling tie bars, additional PCC concrete between the curb and gutter and existing pavement, labor, and equipment will not be paid for separately, but shall be included in the cost of this item.”

- i. Replace Drawing Sheet Nos. 4, 5, 9, 12, 20, and 30 with the attached revised sheets.

## 2. CLARIFICATIONS

- a. The existing combined sewer system on Charles Avenue was previously televised in 2019 by the Village. The videos and spreadsheet log can be downloaded from the link below.

<https://strand.filegenius.com/downloadPublic/u3n5rzykxxtkeuh>

- b. Approximately nothing in this Addendum shall be construed as changing other requirements of the Bidding Documents or the Bid Opening Date. Bids shall be submitted online via QuestCDN.com online bidding. The attached Acknowledgement Form must be filled out and returned with your Bid.

**END OF ADDENDUM NO. 1**

**INDEX OF SPECIAL PROVISIONS**

<b>TITLE</b>	<b>PAGE NO.</b>
SPECIAL PROVISIONS.....	1
DEFINITIONS .....	1
LOCATION OF PROJECT .....	1
DESCRIPTION OF PROJECT .....	1
GENERAL SPECIAL PROVISIONS.....	3
QUALIFICATIONS OF BIDDERS.....	3
BID PRICE LIMITATIONS.....	5
BIDS TO REMAIN SUBJECT TO ACCEPTANCE .....	6
SUBCONTRACTING.....	6
PROGRESS SCHEDULE .....	6
CONTRACT TIME.....	7
FAILURE TO COMPLETE THE WORK ON TIME .....	8
MONIES DUE TO OWNER.....	8
PARTIAL PAYMENTS.....	8
PROGRESS MEETINGS .....	9
TREE CARE.....	9
TREE DAMAGE .....	9
BITUMINOUS MATERIALS .....	11
INSURANCE.....	11
INCREASED OR DECREASED QUANTITIES .....	11
MOBILIZATION.....	12
WINTER WORK.....	12
PORTABLE TOILET.....	12
WORKING HOURS.....	12
HOLIDAYS .....	13

PUBLIC CONVENIENCE AND SAFETY (D-1)..... 13

OPERATION OF WATER DISTRIBUTION FACILITIES ..... 13

CONSTRUCTION SAFETY AND HEALTH STANDARDS ..... 14

FINAL INSPECTION ..... 14

MAINTENANCE WARRANTY..... 14

DUST CONTROL WATERING..... 15

COMPLETION DATE PLUS WORKING DAYS ..... 15

MAINTENANCE OF ROADWAYS ..... 16

KEEPING ROADS OPEN TO TRAFFIC ..... 16

RESPONSIBILITY FOR VANDALISM..... 17

USE OF FIRE HYDRANTS ..... 17

TRENCH BACKFILL AND PIPE BEDDING ..... 18

EXCAVATION AND BACKFILLING OF DRAINAGE AND UTILITY STRUCTURES .... 18

ADJUSTING RINGS..... 18

SALVAGE AND DISPOSAL OF EXISTING MATERIALS ..... 19

DATE OF MANUFACTURE ..... 19

IRON AND STEEL MATERIALS ..... 20

PROTECTION OF EXISTING DRAINAGE FACILITIES DURING CONSTRUCTION... 20

DROP HAMMERS..... 20

PLANTING WOODY PLANTS ..... 20

WEED CONTROL, PRE-EMERGENT GRANULAR HERBICIDE..... 21

TEMPORARY SURFACE OVER TRENCH FOR UTILITY IMPROVEMENTS..... 22

PREPARATION OF BASE ..... 23

HOT-MIX ASPHALT BINDER AND SURFACE COURSE (D-1) ..... 24

REMOVE AND RELOCATE SIGN ASSEMBLY..... 33

FRICITION AGGREGATE (DISTRICT 1)..... 33

GROUND TIRE RUBBER (GTR) MODIFIED ASPHALT BINDER (D-1)..... 36

PAY ITEM SPECIAL PROVISIONS ..... 37

PAY ITEMS #1&2 – TREE STUMP REMOVAL ..... 37

PAY ITEM #6 – TREE ROOT PRUNING ..... 38

PAY ITEM #7&8 – TREE PRUNING ..... 38

PAY ITEM #9 – EXPLORATION TRENCH, SPECIAL ..... 39

PAY ITEM #10 – EARTH EXCAVATION ..... 40

PAY ITEM #14 – TRIAXIAL, GEOGRID REINFORCEMENT ..... 40

PAY ITEM #17 – SODDING, SALT TOLERANT ..... 44

PAY ITEM #26 – INLET FILTERS ..... 44

PAY ITEMS #28, 29, & 30 – TEMPORARY ACCESS ..... 45

PAY ITEM #36 – BITUMINOUS MATERIALS (TACK COAT) ..... 46

PAY ITEMS #37 & #38 – HOT-MIX ASPHALT DRIVEWAY PAVEMENT, 4" AND 6" ... 47

PAY ITEMS #40 & #41 – PORTLAND CEMENT CONCRETE DRIVEWAY PAVEMENT  
..... 47

PAY ITEM #45 – DETECTABLE WARNINGS ..... 48

PAY ITEM #50 – CLASS D PATCHES ..... 48

PAY ITEMS #56, #57, #58, & #59 – STORM SEWERS, CLASS A ..... 49

PAY ITEM #60 –PVC PIPE DRAINS SDR 26 ASTM D-2241, 6" ..... 49

PAY ITEM #61 & #62 – STORM SEWERS, WATER MAIN QUALITY PIPE ..... 50

PAY ITEM #63 - STORM SEWER REMOVAL ..... 51

PAY ITEM #64 AND #65 – DUCTILE IRON WATER MAIN ..... 51

PAY ITEM #66 - WATER MAIN REMOVAL ..... 59

PAY ITEM #67 - ABANDON EXISTING WATER MAIN ..... 59

PAY ITEM #68 - MJ CAP ..... 60

PAY ITEM #69 – FIRE HYDRANTS TO BE REMOVED ..... 60

PAY ITEM #70 – FIRE HYDRANT WITH AUXILIARY VALVE AND VALVE BOX ..... 61

PAY ITEM #71 & #72 – WATER SERVICE CONNECTION ..... 63

PAY ITEM #73 – WATER SERVICE CURB BOX ..... 65

PAY ITEM #74 & #75 – CONNECTION TO EXISTING WATER MAIN ..... 66

PAY ITEM #77 & #78 – VALVE VAULT ..... 67

PAY ITEM #79 – WATER VALVES ..... 68



**APPENDIX A**

- INDEX FOR SUPPLEMENTAL SPECIFICATIONS AND RECURRING SPECIAL PROVISIONS
- IDOT FORMS LR 107-4 (Special Provision for Insurance)
  
- CHECK SHEET FOR RECURRING SPECIAL PROVISIONS
- BDE CHECK SHEET
- BDE SPECIAL PROVISIONS
- STORMWATER POLLUTION PREVENTION PLAN
- ILLINOIS ENVIRONMENTAL PROTECTION AGENCY NOTICE OF INTENT

**APPENDIX B**

- ILLINOIS DEPARTMENT OF TRANSPORTATION (IDOT) HIGHWAY STANDARDS
- IDOT DISTRICT ONE DETAILS

**APPENDIX C**

- REQUIREMENTS OF BIDDERS ORDINANCE

**APPENDIX D**

- IRMA CONTRACTUAL INSURANCE GUIDELINES

**APPENDIX E**

- DUPAGE COUNTY PREVAILING WAGE RATES

**APPENDIX F**

- PRELIMINARY SUBSURFACE EXPLORATION, LABORATORY TESTING AND GEOTECHNICAL ENGINEERING ANALYSIS FOR PROPOSED CHARLES AVENUE IMPROVEMENT PROJECT

**APPENDIX G**

- PERMITS



**CHARLES AVENUE IMPROVEMENTS  
VILLAGE OF VILLA PARK**

**SPECIAL PROVISIONS**

The following Special Provisions supplement the “Standard Specifications for Road and Bridge Construction”, adopted April 1, 2016 (referred to hereinafter as the Standard Specifications); the “Supplemental Specifications and Recurring Special Provisions”, adopted January 1, 2021; the latest edition of the “Illinois Manual on Uniform Traffic Control Devices For Streets and Highways” (IMUTCD); and the “Standard Specifications for Water and Sewer Construction in Illinois”, 7<sup>th</sup> Edition, 2014 (referred to hereinafter as the Water and Sewer Specifications). In case of conflict with any part or parts of said Specifications, these Special Provisions shall take precedence and shall govern. Where no conflict exists, the said Specifications shall apply to this Contract as if repeated in their entirety herein.

**DEFINITIONS**

**Contractor.** The individual, firm, partnership, joint venture, or corporation contracting with the Village of Villa Park for performance of prescribed work.

**Department, Owner or Village.** The Village of Villa Park, DuPage County, Illinois.

**Engineer.** The Resident Engineer who is the authorized representative of the Village of Villa Park in immediate charge of the engineering details of a construction project.

Add the following to Article 101.01:

SSWSC Standard Specifications for Water and Sewer Construction in Illinois, 7th Edition, 2014 and as amended from time to time.

Add the following articles:

**101.56 OWNER.** The Village of Villa Park acting through its legally constituted officials, officers, or employees.

**LOCATION OF PROJECT**

The project is located on Charles Avenue from St. Charles Road to Oak Street in Villa Park, DuPage County, Illinois.

**DESCRIPTION OF PROJECT**

This project consists of improvements on Charles Avenue from St. Charles Road to Oak Street in Villa Park, DuPage County, Illinois. Charles Avenue will be reconstructed with hot-mix asphalt pavement and Portland cement concrete curb and gutter. Existing

**CHARLES AVENUE IMPROVEMENTS  
VILLAGE OF VILLA PARK**

sidewalks will be removed and replaced where indicated on the drawings. The existing combined sewer will be converted to a sanitary sewer. Existing sanitary sewer service and taps will be replaced in select locations. Existing sanitary sewer and services will be cleaned and treated for invasive roots. A new 8-inch water main will be installed and all water services and curb stops in boxes will be replaced. The existing water system will be removed and/or abandoned. New storm sewer will be constructed with associated structures.

**CHARLES AVENUE IMPROVEMENTS  
VILLAGE OF VILLA PARK****GENERAL SPECIAL PROVISIONS****QUALIFICATIONS OF BIDDERS**

Bidder, in submitting a Bid, certifies that Bidder is in compliance with all applicable federal, state, and local laws and requirements, and that Bidder further meets the qualifications prescribed in this and other applicable portions of these provisions. Engineer's determination as to the compliance and qualifications of the Bidder will be final, and Bidder, in submitting a Bid, agrees to be bound by that determination.

Bidder, in submitting a Bid, certifies that Bidder is in compliance with the following requirements and qualifications. Bidder further certifies that Bidder is able to provide written evidence of Bidder's compliance with the following requirements and qualifications. Bidder shall, upon request by Engineer, submit such written evidence within five (5) calendar days of the Engineer's request, as well as any other written evidence which Engineer may deem necessary for the purpose of evaluating Bidder's qualifications.

- (a) Bidder shall be qualified to do business in the State of Illinois.
- (b) Bidder shall possess either a valid Federal Employer Tax Identification Number (FEIN) or a valid Social Security Number (SSN).
- (c) Bidder shall be able to provide a street address and description of the Bidder's place of business, and the mailing address of the business, if different from the street address.
- (d) Bidder shall be able to provide the number of years Bidder has been engaged in the contracting business under the present firm name, and the name of the state where incorporated.
- (e) Bidder shall be able to provide a list of the property and equipment available to the Bidder.
- (f) Bidder shall be able to provide a financial statement demonstrating that the Bidder has the financial resources to meet all obligations related to the Work.
- (g) Bidder shall maintain insurance policies with the coverages required by the Contract, and with the minimum limits of coverage required by the Contract. Bidder shall be able to provide current certificate(s) of insurance for the insurance policies held by Bidder, demonstrating that Bidder holds insurance policies with the coverages required by the contract, and with the minimum limits of coverage required by the Contract.

CHARLES AVENUE IMPROVEMENTS  
VILLAGE OF VILLA PARK

- (h) Bidder shall have constructed a minimum of three (3) projects of a similar nature in the immediate past five (5) years. Bidder shall be able to provide a list of all projects of a similar nature constructed by Bidder in the immediate past five (5) years, which list shall contain the minimum of three (3) such projects, which list shall provide a description and the location(s) of all such projects, and shall contain the Bidder's performance record and references, as well as the names and current contact information, including addresses and telephone numbers, of persons who acted as owners' representatives for those projects and who have knowledge of those projects, and whom Bidder agrees the Village may contact for the purpose of verifying Bidder's performance and references.
- (i) Bidder shall be able to provide a list of three (3) references (name, address and telephone number) with knowledge of the integrity and business practices of the bidder. Such references may not be persons who have been employed by Bidder as employees.
- (j) Bidder shall be able to provide a list of projects presently under Contract, the awarded Contract amount of each, the approximate adjusted Contract amount of each (if applicable), and the dollar amount or percent of completion of each.
- (k) Bidder shall be able to provide a list of Contracts which have resulted in lawsuits, whether against Bidder as a prime contractor, against Bidder as a subcontractor, or against Bidder as a party in any other capacity; or against subcontractors or suppliers performing work for Bidder or under Contract held by Bidder.
- (l) Bidder shall be able to provide a list of Contracts defaulted.
- (m) Bidder shall be able to provide a statement indicating whether or not Bidder has ever filed bankruptcy.
- (n) Bidder shall be able to provide a list of all officers of the firm, which list shall also indicate those officers who, while in the employ of the firm or in the employ of previous firms, were associated with Contracts which resulted in lawsuits, Contracts defaulted, or firms which filed for bankruptcy.
- (o) Bidder shall maintain personnel guaranteed to be employed in the responsible charge of the Work, which personnel possess sufficient technical experience to ensure the satisfactory completion of the Work. Bidder shall be able to provide the names and technical experience of such personnel, as well as statements as to whether the personnel have or have not performed satisfactorily on other contracts of like nature and magnitude or comparable difficulty at similar rate of progress.

**CHARLES AVENUE IMPROVEMENTS  
VILLAGE OF VILLA PARK**

- (p) Bidder shall be able to provide a list of subcontractors and suppliers anticipated to be employed by Bidder for the purpose of completing the Work, including the firm name, street address and description of place of business; mailing address of business (if different); phone, fax and e-mail contact information of business; name of primary contact; and a list of any projects or contracts for which Bidder currently owes monies to said firm, which list shall include a description of the project or contract, the amount currently due to said firm, the period of time for which those monies have been owed, and the expected date of payment of those monies.
- (q) Bidder shall participate in active apprenticeship and training programs approved by and registered with the United States Department of Labor Bureau of Apprenticeship and Training for each of the trades of work contemplated under the Contract. Bidder shall be able to provide evidence of Bidder's participation in such apprenticeship and training programs.
- (r) Bidder shall only employ subcontractors who meet the requirements prescribed in this section and other sections of these specifications.
- (s) Bidder shall be able to provide such other information as may assist the Village in determining whether the Bidder is adequately prepared to fulfill the Contract.

These requirements and qualifications are not intended to discourage bidding, to make it difficult for qualified Bidders to submit Bids, or to discourage beginning contractors. The purpose of these requirements and qualifications is to allow the Village to obtain sufficient information about Bidder's financial state, available equipment, personnel, and previous work experience so that the Village may mitigate the hazards involved in awarding contracts to parties who may not be qualified to perform the Work as specified.

A copy of Village of Villa Park Ordinance No. 3733, amending the requirements of bidders for construction projects, is provided as Appendix C.

**BID PRICE LIMITATIONS**

The bid price for TRAFFIC CONTROL AND PROTECTION shall not exceed 5 percent of the total bid price. If the bid price for TRAFFIC CONTROL AND PROTECTION exceeds 5 percent of the total bid price, the Village may reject the Bid.

The bid price for CONSTRUCTION LAYOUT shall not exceed 2 percent of the total bid price. If the bid price for CONSTRUCTION LAYOUT exceeds 2 percent of the total bid price, the Village may reject the Bid.

**CHARLES AVENUE IMPROVEMENTS  
VILLAGE OF VILLA PARK**

The bid price for PRE-CONSTRUCTION VIDEO RECORDING shall not exceed 1 percent of the total bid price. If the bid price for PRE-CONSTRUCTION VIDEO RECORDING exceeds 1 percent of the total bid price, the Village may reject the Bid.

Bidder, in submitting a Bid, certifies that the Bid is in compliance with these requirements. The Village's determination as to whether or not to reject a Bid that does not comply with these requirements will be final, and Bidder, in submitting a Bid, agrees to be bound by that determination.

**BIDS TO REMAIN SUBJECT TO ACCEPTANCE**

All bids shall remain subject to acceptance by the Village for a period of 60 calendar days from the date of the bid opening. The Village may extend the acceptance period by up to an additional 60 calendar days upon written notice to all bidders by the Village. The Village may, in its sole discretion, release any bid and return the bid bond prior to the end of the acceptance period.

**SUBCONTRACTING**

Add the following to the end of the first paragraph of Article 108.01 of the Standard Specifications:

"Should Contractor fail to respond to such request for proof from Engineer or should Engineer determine that Contractor's response to such request is not sufficient to prove that a proposed subcontractor has the experience, ability, and equipment the work requires, Engineer may prohibit the employ of said subcontractor."

Add the following paragraph to the end of Article 108.01 of the Standard Specifications:

"The apparent low Bidder shall submit to Owner within 7 calendar days after the receipt of bids, a list of the names of Bidder's proposed subcontractors and material suppliers along with a description of the work to be performed or the materials to be supplied by each."

**PROGRESS SCHEDULE**

Revise Article 108.02 of the Standard Specifications to read:

After the award of the contract and prior to starting work, the Contractor shall submit to the Engineer a satisfactory progress schedule or critical path schedule which shall show the proposed sequence of work, and how the Contractor proposes to complete the

**CHARLES AVENUE IMPROVEMENTS  
VILLAGE OF VILLA PARK**

various items of work within the number of calendar days set up in the contract or on or before the completion date specified in the contract.

Work will not be permitted to start until a progress schedule has been submitted and approved. The contract time will commence to run in accordance with the contract documents regardless of whether a progress schedule has been submitted or approved. If the contract time has commenced to run and a progress schedule has not been submitted, the contract time will continue to run until the day that a progress schedule is submitted. The contract time will be suspended upon submittal of a progress schedule and while such progress schedule is under review. The contract time will resume to run upon provision of a response by the Engineer to the submitted progress schedule, regardless of whether such response is approval or rejection.

The progress schedule shall be used as a basis for establishing the controlling item of construction operations and for checking the progress of the work. The controlling item shall be defined as the item which must be completed either partially or completely to permit continuation of progress. It shall be the responsibility of the Contractor to show the intended rate of production for each controlling item listed on the schedule during the period such item is controlling.

The Contractor shall confer with the Engineer at regular intervals in regard to the prosecution of the work according to the progress schedule or critical path schedule.

If at any time the actual progress is ten or more calendar days behind the proposed progress shown on the approved schedule, the Engineer will select the controlling item of work for the purpose of checking the progress of the work. In such cases the Contractor shall submit a satisfactory revised progress schedule or revised critical path schedule. The Engineer will continue to determine the controlling item until the Contractor has submitted a satisfactory revised progress schedule or revised critical path schedule and such schedule has been approved.

Payment under this contract may be withheld if, at any time, a satisfactory and approved progress schedule is not in place.

**CONTRACT TIME**

The work shall be completed by October 8, 2021 unless additional time is granted in accordance with the specifications.

**CHARLES AVENUE IMPROVEMENTS  
VILLAGE OF VILLA PARK**

**FAILURE TO COMPLETE THE WORK ON TIME**

Replace the table in Article 108.09 of the Standard Specifications with the following:

Schedule of Deductions for Each Day of Overrun in Contract Time			
Original Contract Amount		Daily Charges	
From More Than	To and Including	Calendar Day	Work Day
\$ 0	\$ 100,000	\$ 1,500	\$ 2,200
100,000	500,000	2,400	3,400
500,000	1,000,000	3,300	4,600
1,000,000	3,000,000	4,100	5,500
3,000,000	6,000,000	4,600	6,400
6,000,000	12,000,000	7,400	11,000
12,000,000	And over	21,700	30,500

**MONIES DUE TO OWNER**

Should Contractor be subject to fines, deductions, reimbursements, liquidated damages, or other monies due to Owner, the cost thereof may be deducted from any monies due or to become due the Contractor under this contract or any other contract between the Owner and the Contractor. Bidders and Contractor, in submitting Bids, acknowledge this requirement and agree to be bound by it.

**PARTIAL PAYMENTS**

Add the following after the first paragraph of Article 109.07(a) of the Standard Specifications:

“Owner will deduct from the amount so determined for the completed work a sum of ten percent to be retained until the final payment. Owner may, at its discretion, reduce the percentage of such retention prior to the final payment, but in no event shall the amount retained be reduced to less than ten percent prior to substantial completion, nor shall such retention be reduced to less than two percent or less than \$5,000.00 prior to the final payment.

**CHARLES AVENUE IMPROVEMENTS  
VILLAGE OF VILLA PARK****PROGRESS MEETINGS**

Construction progress meetings will be held on a weekly basis beginning when the contract time commences to run and continuing until the project achieves final completion. Owner may, at its discretion, reduce the frequency of such meetings or cancel any or all such meetings. Contractor's representative in responsible charge of the work shall be present at all scheduled progress meetings. If Contractor's representative is not present at one or more scheduled progress meetings, Contractor shall compensate Owner for the costs of attendance of such meetings by Owner's and Engineer's representatives. Owner will determine the rates at which such attendance is to be compensated. Owner will determine the interval or intervals at which billing will take place, and may, at Owner's discretion, submit invoices for payment to Contractor, or deduct the costs from any monies due or to become due to the Contractor from Owner.

**TREE CARE**

Tree care work shall be defined as all tree pruning, tree root pruning, tree planting, tree assessment, and tree remediation. All tree care work shall be in accordance with Section 201 of the Standard Specifications, except as modified herein.

All tree care work shall be performed by an ISA Certified Arborist or shall be performed under the direct supervision of an ISA Certified Arborist. The certified arborist shall submit a copy of their current and valid certificate to the Owner prior to any tree care work taking place. The certified arborist whose certificate is provided shall be on site at all times when tree care work is taking place. All such tree care work shall either be performed by the certified arborist or shall be performed under the direct supervision of the certified arborist.

**TREE DAMAGE**

If any trees are damaged during the project, the Contractor shall obtain and file with the Village a tree assessment of the damaged trees. The tree assessment shall detail the health and condition of the damaged trees and shall provide a recommendation for or against retention of each affected tree. The tree assessment will not be paid for.

When, in the opinion of the Village, a tree assessment obtained by the Contractor does not represent an independent evaluation, the Village may direct the Contractor to obtain a second tree assessment of the damaged trees and may provide the Contractor with a list of not less than two ISA Certified Arborists, from which list the Contractor shall select one for completion of the second tree assessment. The second tree assessment, if so directed, will not be paid for.

**CHARLES AVENUE IMPROVEMENTS  
VILLAGE OF VILLA PARK**

When multiple tree assessments are obtained, it will be the opinion of the Village as to which tree assessment is utilized for the purposes of addressing the remaining requirements of this section. Further references to the tree assessment in this section shall refer to the tree assessment selected by the Village.

If the tree assessment results in a recommendation for retention of an affected tree, the Contractor shall perform tree remediation of the affected tree as follows.

Trees subject to tree remediation will be fertilized and treated with Paclobutrazol. Treatment shall consist of air spading 2 holes for every 3 sq. ft. of area within the dripline of the tree to a depth of 12 in. to 18 in. and backfilling with Biochar.

If a tree subject to tree remediation is an Oak or an Elm species and the damage occurred between the dates of April 15 and October 15, then in addition to the Paclobutrazol treatment specified herein, the damage to the tree will be sealed in a manner approved by the Engineer.

The Owner may require the Contractor to perform additional methods of tree remediation or methods of tree remediation different from those listed if recommended by the tree assessment or deemed appropriate by the Owner.

Tree remediation will not be paid for.

If the tree assessment results in a recommendation against retention of an affected tree, the Contractor shall remove the affected tree. Should removal of the affected tree result in any additional damage to the site or result in the need for any additional restoration, Contractor shall repair or replace the damage or perform the restoration as deemed necessary by the Engineer. This work shall be in accordance with Article 201.04 of the Standard Specifications, except that the work will not be paid for.

If a tree is to be removed due to damage, a deduction will be applied to monies due or that might become due the Contractor. This Tree Damage Deduction will be applied as follows.

Trees to be removed due to damage will be measured per unit of diameter where one unit is equal to 1 in. The diameter will be measured at a point 4.5 ft. above the highest ground level at the base of the tree and will be determined by dividing the measured circumference of the tree by 3.1416.

If the tree had tree protection installed at the time of damage and if, in the opinion of the Village, the tree protection was correctly installed at the time of damage, the Tree Damage Deduction will be \$300 per unit of diameter of the tree.

**CHARLES AVENUE IMPROVEMENTS  
VILLAGE OF VILLA PARK**

If the tree did not have tree protection installed at the time of damage or if, in the opinion of the Village, the tree protection was not correctly installed at the time of damage, the Tree Damage Deduction will be \$800 per unit of diameter of the tree.

If a tree is to be removed due to damage, then in addition to the Tree Damage Deduction, Contractor shall also furnish and plant a tree of a species and caliper selected by the Owner at a location determined by the Owner. This work shall be in accordance with Section 253 of the Standard Specifications, except that the work will not be paid for.

**BITUMINOUS MATERIALS**

Prime coat will not be applied on aggregate bases as a part of this contract.

Tack coat shall be in accordance with the pay item special provision BITUMINOUS MATERIALS (TACK COAT).

**INSURANCE**

Insurance and indemnification shall be in accordance with applicable sections of the Standard Specifications, and shall also be in accordance with the "IRMA Contractual Insurance Guidelines", incorporated herein as Appendix D. If a conflict is determined to exist between the requirements prescribed in the Standard Specifications and the requirements prescribed in the IRMA Contractual Insurance Guidelines, such conflict will be resolved as follows:

- a. If a particular type of insurance coverage is required by one standard but not by both, that type of insurance coverage will be required.
- b. If the minimum limits of insurance coverage required by one standard differ from those required by the other standard, the higher minimum limits of insurance coverage will prevail.
- c. If any other conflicts are determined to exist between the requirements prescribed in the two standards, the stricter of the two requirements will prevail. The Village will make the final determination as to what constitutes a stricter requirement.

**INCREASED OR DECREASED QUANTITIES**

The Village reserves the right to increase or decrease the amount of work shown in the plans in accordance with Section 109 of the Standard Specifications.

CHARLES AVENUE IMPROVEMENTS  
VILLAGE OF VILLA PARK**MOBILIZATION**

Mobilization shall be in accordance with Section 671 of the Standard Specifications, except as modified herein.

Revise Article 671.02, Basis of Payment, to read:

**“671.02 Basis of Payment.** This work will not be paid for separately but shall be included in the unit bid prices of the items for which this work applies.”

**WINTER WORK**

If Contractor elects to begin any site work before or during winter, no additional compensation will be granted for any costs or delays incurred by the Contractor as a result of winter weather. The Contractor shall be responsible for the implementation and cost of any winter shutdown provisions which are deemed necessary by the Engineer.

**PORTABLE TOILET**

Contractor shall furnish a portable toilet meeting federal, state, and local health department requirements stocked with lavatory and sanitary supplies at all times. The portable toilet shall be provided at a location approved by the Engineer. The portable toilet shall be maintained in a clean and sanitary condition and shall be emptied as needed. This work will not be paid for separately but shall be included in the cost of the Contract.

**WORKING HOURS**

Working hours will be between 7:00 A.M. and 5:00 P.M., Monday through Friday, excluding holidays as designated by the Contract.

Contractor will not permit the performance of Work outside these working hours without Owner's written consent, which may be given after prior written request to Engineer, except as otherwise required for the safety of persons or the Work or property at the Site or adjacent thereto, and except as otherwise stated in the Contract Documents.

If Contractor permits the performance of Work outside these working hours, Contractor will compensate Owner for the costs of inspection and other services provided by Engineer. Owner will determine the rates at which such inspection and other services are to be compensated. Owner will determine the interval or intervals at which billing will take place, and may, at Owner's discretion, submit invoices for payment to Contractor, or deduct the costs from any monies due or to become due to the Contractor from Owner.

**CHARLES AVENUE IMPROVEMENTS  
VILLAGE OF VILLA PARK**

**HOLIDAYS**

Revise the list of legal holidays in Article 107.09 of the Standard Specifications to read:

New Year's Day	Thanksgiving Day
Easter	<i>Thanksgiving Friday</i>
Memorial Day	<i>Christmas Eve</i>
Independence Day	Christmas Day
Labor Day	<i>New Year's Eve</i>

**PUBLIC CONVENIENCE AND SAFETY (D-1)**

Effective: May 1, 2012

Revised: July 15, 2012

Add the following to the end of the fourth paragraph of Article 107.09:

"If the holiday is on a Saturday or Sunday, and is legally observed on a Friday or Monday, the length of Holiday Period for Monday or Friday shall apply."

Add the following sentence after the Holiday Period table in the fourth paragraph of Article 107.09:

"The Length of Holiday Period for Thanksgiving shall be from 5:00 A.M. the Wednesday prior to 11:59 P.M. the Sunday After."

Delete the fifth paragraph of Article 107.09 of the Standard Specifications:

"On weekends, excluding holidays, on roadways with Average Daily Traffic of 25,000 or greater, all lanes shall be open to traffic from 3:00 P.M. Friday to midnight Sunday except where structure construction or major rehabilitation makes it impractical."

**OPERATION OF WATER DISTRIBUTION FACILITIES**

Contractor shall not operate any water distribution facilities, including, but not limited to, valves or hydrants. If Contractor requires the operation of such facilities, Contractor shall provide a minimum of 48 hours' notice to the Village and the Village will operate such facilities.

**CHARLES AVENUE IMPROVEMENTS  
VILLAGE OF VILLA PARK****CONSTRUCTION SAFETY AND HEALTH STANDARDS**

It is a condition of this contract and shall be made a condition of each subcontract entered into pursuant to this contract that the Contractor and any Subcontractor shall not require any laborer or mechanic employed in performance of that contract to work in surroundings or under working conditions which are unsanitary, hazardous or dangerous to their health or safety, as determined under Federal Construction Safety and Health Standards.

**FINAL INSPECTION**

Final inspection shall be in accordance with Article 105.13 of the Standard Specifications, except as modified herein.

Revise the second paragraph of Article 105.13, Final Inspection, to read:

“If the inspection discloses any work, in whole or in part, as being unsatisfactory, the Engineer will give the Contractor the necessary instructions for correction of same, and the Contractor shall comply with such instructions within 14 calendar days of receipt of such instructions. The Contractor shall give the Engineer not less than 48 hours’ notice, in writing, prior to beginning any such corrective work. Upon completion of all corrective work, the Contractor shall give the Engineer notice in writing. Upon receipt of such notice, the Engineer will make another inspection which shall constitute the final inspection provided the work has been satisfactorily completed. In such event, the Engineer will notify the Contractor in writing of the date of final inspection.”

**MAINTENANCE WARRANTY**

The Contractor shall execute and deliver to the Village, before final payment will be issued, a written warranty, in a form satisfactory to the Village, which guarantees that all work is in accordance with the contract and will not be defective. This warranty shall guarantee all work for a period of 1 year from the date of final inspection.

The Contractor shall furnish a warranty bond in an amount equal to 10 percent of the final contract amount, or \$180,000.00, whichever is greater, by a surety satisfactory to the Village to guarantee Contractor’s warranty to repair defective work.

If, within the warranty period, the Village determines any work to be defective, a written notice of such deficiency will be sent to the Contractor by certified mail.

The Contractor shall, within 14 calendar days of receipt of the notice of deficiency and without cost to the Village, correct or repair such defective work, or remove and replace the defective work in accordance with the Contract requirements for the item or items in question.

**CHARLES AVENUE IMPROVEMENTS  
VILLAGE OF VILLA PARK**

If Contractor desires an extension of time to complete the corrective work, Contractor shall make such request in writing within 10 calendar days of receipt of the notice of deficiency. After the Contractor has filed a request for an extension of time, the Village will notify the Contractor, in writing, whether or not such extension will be approved.

Should the Contractor fail to complete the corrective work within the 14 calendar days or within such extended time as may have been allowed, the Contractor shall be liable and shall pay to the Village the amount shown in the Schedule of Deductions for Each Day of Overrun in Contract Time, not as a penalty but as liquidated damages, for each day of overrun beyond the 14 calendar days or such extended time as may have been allowed.

**DUST CONTROL WATERING**

**Description:** This work shall consist of furnishing and applying water to control dust and airborne dirt generated by construction activities.

**General:** This work shall be performed according to Article 107.36 of the "Standard Specifications" and the following:

Revise Article 107.36 of the "Standard Specifications" as follows:

If the Contractor is not controlling the dust sufficiently, additional applications must be performed.

Replace subparagraph (d) of under the third paragraph with the following:

(d) Dust shall be controlled by the uniform application of sprinkled water and shall be applied only when requested and in a manner acceptable to the Engineer. All equipment used for this work shall be equipped with adequate measuring devices for determining the exact amount of water discharged. All water used shall be properly documented by ticket or other approved means.

**Method of Measurement:** This work will not be measured for payment.

**Basis of Payment:** This work will be paid separately and shall be included in the cost of the Contract.

**COMPLETION DATE PLUS WORKING DAYS**

Revise Article 108.05 (b) of the Standard Specifications as follows:



CHARLES AVENUE IMPROVEMENTS  
VILLAGE OF VILLA PARK

**RESPONSIBILITY FOR VANDALISM**

The Contractor shall be responsible for the protection of all equipment and materials. Any equipment or materials which are stolen, missing, lost, damaged, or vandalized shall be the Contractor’s responsibility to replace or repair as needed at no additional cost to the Contract.

The Contractor shall be responsible for the defacement of any concrete pours before they have set up. Concrete pavement, sidewalk, driveway, or curbing that has been defaced, in the opinion of the Engineer, shall be removed and replaced by the Contractor at Contractor’s expense.

**USE OF FIRE HYDRANTS**

Revise Article 107.18, Use of Fire Hydrants, of the Standard Specifications to read:

**“107.18 Use of Fire Hydrants.** If Contractor requires water for the completion of construction operations, and desires to obtain water from the Village, the Contractor shall make written application to the Village. If such application is approved by the Village, the Contractor shall obtain water from the fire hydrant located at 100 West Home Avenue, adjacent to the Village of Villa Park Fleet Maintenance Garage. Contractor’s use of said hydrant and methods of obtaining water shall be in compliance with all applicable ordinances, rules, and regulations concerning such use. Contractor shall furnish all labor and equipment necessary to make a connection to said hydrant, and to obtain and transport water.

Prior to obtaining water, Contractor shall make written application to the Village for temporary use of a hydrant meter. If the application for temporary use of a hydrant meter is approved, the Contractor shall provide a deposit of three-thousand dollars (\$3,000.00) to the Village for the temporary use of said hydrant meter, which deposit will be held by the Village until such time that the meter is returned to the Village by the Contractor in satisfactory condition. Contractor shall use said hydrant meter when obtaining water and shall comply with all conditions for the use of said meter. Contractor shall return the hydrant meter to the Village within 24 hours of project completion and within 24 hours of any request by the Village that the hydrant meter be returned.

If Contractor makes application for temporary use of a hydrant meter and the application is not approved, Contractor shall make record of the quantity of water obtained, along with the date and time obtained, and shall report such information after each use to the Village of Villa Park Public Works Department, 11 West Home Avenue. If such use takes place outside of the normal working hours of the Public Works Department, Contractor shall report such information immediately upon the commencement of normal working hours.

**CHARLES AVENUE IMPROVEMENTS  
VILLAGE OF VILLA PARK**

Contractor shall not use, operate, or obtain water from any hydrants other than the hydrant prescribed. Contractor shall not obtain water from the Village for construction operations or activities not under contract with the Village.

If a water main break occurs and the Village determines that the water main break is a result of Contractor's use of a hydrant, the Village may require the Contractor to repair the water main break in accordance with all applicable construction standards and requirements and at no cost to the Contract, or may repair the water main break by other means and invoice the Contractor for reimbursement of the Village's costs.

Water usage will be measured according to the Special Provisions WATER USAGE DEDUCTION and WATER USAGE CREDIT."

**TRENCH BACKFILL AND PIPE BEDDING**

All trench backfill and pipe bedding materials furnished under this contract shall be virgin, non-recycled materials.

All trench backfill shall be crushed aggregate of CA-6 gradation. The aggregate material shall be placed in lifts not exceeding 8 in. in depth, loose measurement, and compacted by mechanical means to the satisfaction of the Engineer.

All pipes installed under this contract shall be placed on a bedding of crushed aggregate of CA-7 or CA-11 gradation having a minimum thickness of 4 inches. The bedding shall be placed to a minimum of 12 inches above the top of the pipe and any fittings.

The cost of furnishing and installing pipe bedding materials will not be paid for separately but shall be included in the cost of items to which this work pertains.

**EXCAVATION AND BACKFILLING OF DRAINAGE AND UTILITY STRUCTURES**

Excavation, bedding and backfilling of drainage and utility structures which are constructed, reconstructed, or adjusted as a part of this contract will not be paid for separately but shall be included in the cost of the items to which this work pertains.

**ADJUSTING RINGS**

All drainage and utility structures which are constructed, reconstructed, or adjusted as a part of this Contract shall have adjusting rings installed between the topmost section of the structure and the casting.





CHARLES AVENUE IMPROVEMENTS  
VILLAGE OF VILLA PARK

"Trees, shrubs, and vines shall be thoroughly watered with a method acceptable to the Engineer. Place backfill in 6 inch-thick layers. Work each layer by hand to compact backfill and eliminate voids. Maintain plumb during backfilling. When backfill is approximately 2/3 complete, saturate backfill with water and repeat until no more water can be absorbed. Place and compact remainder of backfill and thoroughly water again. Approved watering equipment shall be at the site of the work and in operational condition prior to starting the planting operation and during all planting operations or planting will not be allowed."

Add the following to Article 253.10(e):

"Spade a planting bed edge at approximately a 45-degree angle and to a depth of approximately 3 inches (75 mm) around the perimeter of the tree bed. Remove any debris created in the spade edging process and disposed of as specified in Article 202.03."

Delete Article 253.11 and substitute the following:

"Within 48 hours after planting, mulch shall be placed around all plants in the entire mulched bed or saucer area specified to a depth of 4 inches (100 mm). Mulch shall not be in contact with the base of the trunk. No weed barrier fabric will be required for tree and shrub planting unless otherwise noted on the drawings. Pre-emergent Herbicide will be used instead of weed barrier fabric in areas to receive hardwood mulch. The pre-emergent herbicide shall be applied prior to mulching. See specification for Weed Control, Pre-Emergent Granular Herbicide."

**WEED CONTROL, PRE-EMERGENT GRANULAR HERBICIDE**

**Description.** This work shall consist of spreading a pre-emergent granular herbicide in mulched plant beds and mulch rings.

**Materials:** The pre-emergent granular herbicide shall contain the chemicals Trifluralin 2% active ingredient and Isoxaben with 0.5% active ingredient. The herbicide label shall be submitted to the Engineer for approval at least seventy-two (72) hours prior to application.

**Method:** The pre-emergent granular herbicide shall be used in accordance with the manufacturer's directions on the package. The granules are to be applied prior to mulching.

Apply the granular herbicide using a drop or rotary-type designed to apply granular herbicide or insecticides. Calibrate application equipment to use according to manufacturer's directions. Check frequently to be sure equipment is working properly and distributing granules uniformly. Do not use spreaders that apply material in narrow concentrated bands. Avoid skips or overlaps as poor weed control or crop injury may

CHARLES AVENUE IMPROVEMENTS  
VILLAGE OF VILLA PARK

occur. More uniform application may be achieved by spreading half of the required amount of product over the area and then applying the remaining half in swaths at right angles to the first. Apply the granular herbicide at the rate of 100 lbs/acre (112 kg/ha) or 2.3 lbs/1000 sq. ft. (11.2 kg/1000 sq. meters).

**Method of Measurement:** Pre-emergent granular herbicide will not be measured for payment.

**Basis of Payment:** This work will not be paid for separately and shall be included in the cost of the various trees, woody plant, and perennial plant pay items.

**TEMPORARY SURFACE OVER TRENCH FOR UTILITY IMPROVEMENTS**

This work shall be in accordance with Section 400 of the Standard Specifications, the details in the drawings, and the following special provision.

This work consists of the installation and removal of temporary surface over excavated trenches for utility improvements prior to the temporary pavement or permanent surface restoration being installed.

The Contractor may use stone, steel plates, or any other means acceptable to the Engineer to maintain access. If stone is used and kept clean, it may be used in the construction of the driveways or roadway, with permission of the Engineer.

**“402.10 For Temporary Access.** The contractor shall construct and maintain aggregate surface course for temporary access to private entrances, commercial entrances and roads according to Article 402.07 and as directed by the Engineer.

The aggregate surface course shall be constructed flush with the existing surface grade.

- (a) In sidewalks. The minimum compacted thickness shall be 4 inches (150 mm) if stone is used.

Maintaining the temporary surface over trench shall include relocating and/or regrading the aggregate surface course for any operation that may disturb or remove the temporary surface. When use of the temporary surface over trench is discontinued, the aggregate shall be removed and utilized in the permanent construction or disposed of according to Article 202.03.”

Revise the second paragraph of Article 402.13 of the Standard Specifications to read:

“Temporary surface over trench will not be paid for separately but shall be included in the cost of the utility pipe. If a trench is to be excavated under multiple stages, the

**CHARLES AVENUE IMPROVEMENTS  
VILLAGE OF VILLA PARK**

temporary surface over trench needed to construct the second or subsequent stages will not be measured for payment.”

**PREPARATION OF BASE**

Delete article 358.06 and replace with the following;

“Preparation of base will not be measured for payment.”

Delete article 358.07 and replace with the following;

“Preparation of base will not be paid for separately and shall be included in the cost of binder course.”

**CHARLES AVENUE IMPROVEMENTS  
VILLAGE OF VILLA PARK**

**HOT-MIX ASPHALT BINDER AND SURFACE COURSE (D-1)**

Effective: November 1, 2019

Revised: November 1, 2020

Description. This work shall consist of constructing a hot-mix asphalt (HMA) binder and/or surface course on a prepared base. Work shall be according to Sections 406 and 1030 of the Standard Specifications, except as modified herein.

Materials. Revise Article 1004.03(c) to read:

“(c) Gradation. The coarse aggregate gradations shall be as listed in the following table.

Use	Size/Application	Gradation No.
Class A-1, A-2, & A-3	3/8 in. (10 mm) Seal	CA 16 or CA 20
Class A-1	1/2 in. (13 mm) Seal	CA 15
Class A-2 & A-3	Cover Coat	CA 14
HMA High ESAL	IL-19.0; Stabilized Subbase IL-19.0	CA 11 <sup>1/</sup>
	SMA 12.5 <sup>2/</sup>	CA 13 <sup>4/</sup> , CA 14, or CA 16
	SMA 9.5 <sup>2/</sup>	CA 13 <sup>3/4/</sup> or CA 16 <sup>3/</sup>
	IL-9.5	CA 16, CM 13 <sup>4/</sup>
	IL-9.5FG	CA 16
HMA Low ESAL	IL-19.0L	CA 11 <sup>1/</sup>
	IL-9.5L	CA 16

1/ CA 16 or CA 13 may be blended with the CA 11.

2/ The coarse aggregates used shall be capable of being combined with stone sand, slag sand, or steel slag sand meeting the FA/FM 20 gradation and mineral filler to meet the approved mix design and the mix requirements noted herein.

3/ The specified coarse aggregate gradations may be blended.

4/ CA 13 shall be 100 percent passing the 1/2 in. (12.5mm) sieve.”

Revise Article 1004.03(e) of the Supplemental Specifications to read:

“(e) Absorption. For SMA the coarse aggregate shall also have water absorption ≤ 2.0 percent.”

CHARLES AVENUE IMPROVEMENTS  
VILLAGE OF VILLA PARK

HMA Nomenclature. Revise the “High ESAL” portion of the table in Article 1030.01 to read:

“High ESAL	Binder Courses	IL-19.0, IL-9.5, IL-9.5FG, IL-4.75, SMA 12.5, Stabilized Subbase IL-19.0
	Surface Courses	IL-9.5, IL-9.5FG, SMA 12.5, SMA 9.5”

Revise Article 1030.02 of the Standard Specifications and Supplemental Specifications to read:

“**1030.02 Materials.** Materials shall be according to the following.

Item	Article/Section
(a) Coarse Aggregate .....	1004.03
(b) Fine Aggregate .....	1003.03
(c) RAP Material .....	1031
(d) Mineral Filler .....	1011
(e) Hydrated Lime .....	1012.01
(f) Slaked Quicklime (Note 1)	
(g) Performance Graded Asphalt Binder (Note 2) .....	1032
(h) Fibers (Note 3)	
(i) Warm Mix Asphalt (WMA) Technologies (Note 4)	

Note 1. Slaked quicklime shall be according to ASTM C 5.

Note 2. The asphalt binder shall be an SBS PG 76-28 when the SMA is used on a full-depth asphalt pavement and SBS PG 76-22 when used as an overlay, except where modified herein. The asphalt binder shall be a SBS PG 76-22 for IL-4.75, except where modified herein. The elastic recovery shall be a minimum of 80.

Note 3. A stabilizing additive such as cellulose or mineral fiber shall be added to the SMA mixture according to Illinois Modified AASHTO M 325. The stabilizing additive shall meet the Fiber Quality Requirements listed in Illinois Modified AASHTO M 325. Prior to approval and use of fibers, the Contractor shall submit a notarized certification by the producer of these materials stating they meet these requirements. Reclaimed Asphalt Shingles (RAS) may be used in Stone Matrix Asphalt (SMA) mixtures designed with an SBA polymer modifier as a fiber additive if the mix design with RAS included meets AASHTO T305 requirements. The RAS shall be from a certified source that produces either Type 1 or Type 2. Material shall meet requirements noted herein and the actual dosage rate will be determined by the Engineer.

**CHARLES AVENUE IMPROVEMENTS  
VILLAGE OF VILLA PARK**

Note 4. Warm mix additives or foaming processes shall be selected from the Department's Qualified Producer List, "Technologies for the Production of Warm Mix Asphalt (WMA)."

Mixture Design. Revise Article 1030.04(a)(1) of the Standard Specifications and the Supplemental Specifications to read:

High ESAL, MIXTURE COMPOSITION (% PASSING) <sup>1/</sup>										
Sieve Size	IL-19.0 mm		SMA 12.5		SMA 9.5		IL-9.5mm		IL-4.75 mm	
	min	max	min	max	min	max	min	max	min	max
1 1/2 in. (37.5 mm)										
1 in. (25 mm)		100								
3/4 in. (19 mm)	90	100		100						
1/2 in. (12.5 mm)	75	89	80	100		100		100		100
3/8 in. (9.5 mm)				65	90	100	90	100		100
#4 (4.75 mm)	40	60	20	30	36	50	34	69	90	100
#8 (2.36 mm)	20	42	16	24 <sup>4/</sup>	16	32 <sup>4/</sup>	34 <sup>5/</sup>	52 <sup>2/</sup>	70	90
#16 (1.18 mm)	15	30					10	32	50	65
#30 (600 μm)			12	16	12	18				
#50 (300 μm)	6	15					4	15	15	30
#100 (150 μm)	4	9					3	10	10	18
#200 (75 μm)	3	6	7.0	9.0 <sup>3/</sup>	7.5	9.5 <sup>3/</sup>	4	6	7	9 <sup>3/</sup>
#635 (20 μm)			≤ 3.0		≤ 3.0					
Ratio Dust/Asphalt Binder		1.0		1.5		1.5		1.0		1.0

- 1/ Based on percent of total aggregate weight.
- 2/ The mixture composition shall not exceed 44 percent passing the #8 (2.36 mm) sieve for surface courses with Ndesign = 90.
- 3/ Additional minus No. 200 (0.075 mm) material required by the mix design shall be mineral filler, unless otherwise approved by the Engineer.

**CHARLES AVENUE IMPROVEMENTS  
VILLAGE OF VILLA PARK**

- 4/ When establishing the Adjusted Job Mix Formula (AJMF) the percent passing the #8 (2.36 mm) sieve shall not be adjusted above the percentage stated on the table.
- 5/ When establishing the Adjusted Job Mix Formula (AJMF) the percent passing the #8 (2.36 mm) sieve shall not be adjusted below 34 percent.

Revise Article 1030.04(b)(1) of the Standard Specifications to read:

“(1) High ESAL Mixtures. The target value for the air voids of the HMA shall be 4.0 percent, for IL-4.75 it shall be 3.5 percent and for Stabilized Subbase it shall be 3.0 percent at the design number of gyrations. The voids in the mineral aggregate (VMA) and voids filled with asphalt binder (VFA) of the HMA design shall be based on the nominal maximum size of the aggregate in the mix and shall conform to the following requirements.

VOLUMETRIC REQUIREMENTS High ESAL				
Ndesign	Voids in the Mineral Aggregate (VMA), % minimum			Voids Filled with Asphalt Binder (VFA), %
	IL-19.0; Stabilized Subbase IL- 19.0	IL-9.5	IL-4.75 <sup>1/</sup>	
50	13.5	15.0	18.5	65 – 78 <sup>2/</sup>
70				65 - 75
90				

1/ Maximum draindown for IL-4.75 shall be 0.3 percent.

2/ VFA for IL-4.75 shall be 72-85 percent.”

Revise the table in Article 1030.04(b)(3) to read:

“VOLUMETRIC REQUIREMENTS, SMA 12.5 <sup>1/</sup> and SMA 9.5 <sup>1/</sup>			
Ndesign	Design Air Voids Target %	Voids in the Mineral Aggregate (VMA), % min.	Voids Filled with Asphalt (VFA), %
80 <sup>4/</sup>	3.5	17.0 <sup>2/</sup>	75 - 83
		16.0 <sup>3/</sup>	

**CHARLES AVENUE IMPROVEMENTS  
VILLAGE OF VILLA PARK**

- 1/ Maximum draindown shall be 0.3 percent. The draindown shall be determined at the JMF asphalt binder content at the mixing temperature plus 30 °F.
- 2/ Applies when specific gravity of coarse aggregate is  $\geq 2.760$ .
- 3/ Applies when specific gravity of coarse aggregate is  $< 2.760$ .
- 4/ Blending of different types of aggregate will not be permitted. For surface course, the coarse aggregate can be crushed steel slag, crystalline crushed stone or crushed sandstone. For binder course, coarse aggregate shall be crushed stone (dolomite), crushed gravel, crystalline crushed stone, or crushed sandstone.

Add to the end of Article 1030.05 (d) (2) a. of the Standard Specifications:

“During production, the Contractor shall test SMA mixtures for draindown according to AASHTO T305 at a frequency of 1 per day of production.”

Revise the last paragraph of Article 1102.01 (a) (5) of the Standard Specifications to read:

“IL-4.75 and Stone Matrix Asphalt (SMA) mixtures which contain aggregate having absorptions greater than or equal to 2.0 percent, or which contain steel slag sand, shall have minimum surge bin storage plus haul time of 1.5 hours.”

Quality Control/Quality Assurance (QC/QA). Revise the third paragraph of Article 1030.05(d)(3) to read:

“If the Contractor and Engineer agree the nuclear density test method is not appropriate for the mixture, cores shall be taken at random locations determined according to the QC/QA document "Determination of Random Density Test Site Locations". Core densities shall be determined using the Illinois Modified AASHTO T 166 or T 275 procedure.”

Add the following paragraphs to the end of Article 1030.05(d)(3):

“Longitudinal joint density testing shall be performed at each random density test location. Longitudinal joint testing shall be located at a distance equal to the lift thickness or a minimum of 4 in. (100 mm), from each pavement edge (i.e. for a 5 in. (125 mm) lift the near edge of the density gauge or core barrel shall be within 5 in. (125 mm) from the edge of pavement). Longitudinal joint density testing shall be performed using either a correlated nuclear gauge or cores.

**CHARLES AVENUE IMPROVEMENTS  
VILLAGE OF VILLA PARK**

- a. **Confined Edge.** Each confined edge density shall be represented by a one-minute nuclear density reading or a core density and shall be included in the average of density readings or core densities taken across the mat which represents the Individual Test.
- b. **Unconfined Edge.** Each unconfined edge joint density shall be represented by an average of three one-minute density readings or a single core density at the given density test location and shall meet the density requirements specified herein. The three one-minute readings shall be spaced 10 ft (3 m) apart longitudinally along the unconfined pavement edge and centered at the random density test location.

When a longitudinal joint sealant (LJS) is applied, longitudinal joint density testing will not be required on the joint(s) sealed.”

Revise the second table in Article 1030.05(d)(4) and its notes to read:

"DENSITY CONTROL LIMITS			
Mixture Composition	Parameter	Individual Test (includes confined edges)	Unconfined Edge Joint Density, minimum
IL-4.75	Ndesign = 50	93.0 – 97.4 % <sup>1/</sup>	91.0%
IL-9.5FG	Ndesign = 50 - 90	93.0 – 97.4 %	91.0%
IL-9.5	Ndesign = 90	92.0 – 96.0 %	90.0%
IL-9.5, IL-9.5L,	Ndesign < 90	92.5 – 97.4 %	90.0%
IL-19.0	Ndesign = 90	93.0 – 96.0 %	90.0%
IL-19.0, IL-19.0L	Ndesign < 90	93.0 <sup>2/</sup> – 97.4 %	90.0%
SMA	Ndesign = 80	93.5 – 97.4 %	91.0%

1/ Density shall be determined by cores or by correlated, approved thin lift nuclear gauge.

2/ 92.0 % when placed as first lift on an unimproved subgrade.”

Equipment. Add the following to Article 1101.01 of the Standard Specifications:

“(h) **Oscillatory Roller.** The oscillatory roller shall be self-propelled and provide a smooth operation when starting, stopping, or reversing directions. The oscillatory roller shall be able to operate in a mode that will provide tangential impact force with or without vertical impact force by using at least one drum. The oscillatory

**CHARLES AVENUE IMPROVEMENTS  
VILLAGE OF VILLA PARK**

roller shall be equipped with water tanks and sprinkling devices, or other approved methods, which shall be used to wet the drums to prevent material pickup. The drum(s) amplitude and frequency of the tangential and vertical impact force shall be approximately the same in each direction and meet the following requirements:

- (1) The minimum diameter of the drum(s) shall be 42 in. (1070 mm);
- (2) The minimum length of the drum(s) shall be 57 in. (1480 mm);
- (3) The minimum unit static force on the drum(s) shall be 125 lb/in. (22 N/m); and
- (4) The minimum force on the oscillatory drum shall be 18,000 lb (80 kN)."

Construction Requirements.

Add the following to Article 406.03 of the Standard Specifications:

"(j) Oscillatory Roller ..... 1101.01"

Revise the third paragraph of Article 406.05(a) to read:

"All depressions of 1 in. (25 mm) or more in the surface of the existing pavement shall be filled with binder. At locations where heavy disintegration and deep spalling exists, the area shall be cleaned of all loose and unsound material, tacked, and filled with binder (hand method)."

Revise Article 406.05(c) to read.

"(c) Binder (Hand Method). Binder placed other than with a finishing machine will be designated as binder (hand method) and shall be compacted with a roller to the satisfaction of the Engineer. Hand tamping will be permitted when approved by the Engineer."

Revise the special conditions for mixture IL-4.75 in Article 406.06(b)(2)e. to read:

"e. The mixture shall be overlaid within 5 days of being placed."

Revise Article 406.06(d) to read:

"(d) Lift Thickness. The minimum compacted lift thickness for HMA binder and surface courses shall be as follows.

**CHARLES AVENUE IMPROVEMENTS  
VILLAGE OF VILLA PARK**

MINIMUM COMPACTED LIFT THICKNESS	
Mixture Composition	Thickness, in. (mm)
IL-4.75	3/4 (19) - over HMA surfaces <sup>1/</sup> 1 (25) - over PCC surfaces <sup>1/</sup>
IL-9.5FG	1 1/4 (32)
IL-9.5, IL-9.5L	1 1/2 (38)
SMA 9.5	1 3/4 (45)
SMA 12.5	2 (51)
IL-19.0, IL-19.0L	2 1/4 (57)

1/ The maximum compacted lift thickness for mixture IL-4.75 shall be 1 1/4 in. (32 mm).”

Revise Table 1 and Note 3/ of Table 1 in Article 406.07(a) of the Standard Specifications to read:

"TABLE 1 - MINIMUM ROLLER REQUIREMENTS FOR HMA				
	Breakdown Roller (one of the following)	Intermediate Roller	Final Roller (one or more of the following)	Density Requirement
Binder and Surface <sup>1/</sup>	V <sub>D</sub> , P <sup>3/</sup> , T <sub>B</sub> , 3W, O <sub>T</sub> , O <sub>B</sub>	P <sup>3/</sup> , O <sub>T</sub> , O <sub>B</sub>	V <sub>S</sub> , T <sub>B</sub> , T <sub>F</sub> , O <sub>T</sub>	As specified in Articles: 1030.05(d)(3), (d)(4), and (d)(7).
IL-4.75 and SMA <sup>4/ 5/</sup>	T <sub>B</sub> , 3W, O <sub>T</sub>	--	T <sub>F</sub> , 3W, O <sub>T</sub>	
Bridge Decks <sup>2/</sup>	T <sub>B</sub>	--	T <sub>F</sub>	As specified in Articles 582.05 and 582.06.

3/ A vibratory roller (V<sub>D</sub>) or oscillatory roller (O<sub>T</sub> or O<sub>B</sub>) may be used in lieu of the pneumatic-tired roller on mixtures containing polymer modified asphalt binder.

4/ The Contractor shall provide two steel-wheeled tandem (T<sub>B</sub>) or three-wheel (3W) rollers for breakdown, except one of the (T<sub>B</sub>) or (3W) rollers shall be 84 inches (2.14 m) wide and a weight of 315 pound per linear inch (PLI) (5.63 kg/mm). 3W, T<sub>B</sub> and T<sub>F</sub> rollers shall be a minimum of 280 lb/in. (50 N/mm). The 3W and T<sub>B</sub> rollers shall be operated at a uniform speed not to exceed 3 mph (5 km/h), with the drive roll for T<sub>B</sub> rollers nearest the paver and maintain an effective rolling distance of not more than 150 ft (45 m) behind the paver.”



**CHARLES AVENUE IMPROVEMENTS  
VILLAGE OF VILLA PARK**

Ndesign specified; HOT-MIX ASPHALT SURFACE COURSE, of the mixture composition, friction aggregate, and Ndesign specified;.”

**REMOVE AND RELOCATE SIGN ASSEMBLY**

**Description.** This work shall consist of removing, temporarily storing, and relocating sign assemblies and posts. This work shall be in accordance with Sections 724, 728, 729, and 730 of the Standard Specifications, the details in the drawings, and the following special provision.

Where indicated in the plans, existing sign panels and posts shall be carefully removed by the Contractor and stored offsite until construction activities are complete near the location area. The sign post shall be driven into the ground at the new location per the applicable section of the Standard Specifications according to the existing post material.

**Method of Measurement and Basis of Payment.** This work will not be measured for payment and shall be included in the cost of the project.

**FRICTION AGGREGATE (DISTRICT 1)**

Effective: January 1, 2011  
Revised: November 1, 2019

Revise Article 1004.03(a) of the Standard Specifications to read:

**“1004.03 Coarse Aggregate for Hot-Mix Asphalt (HMA).** The aggregate shall be according to Article 1004.01 and the following.

(a) Description. The coarse aggregate for HMA shall be according to the following table.

Use	Mixture	Aggregates Allowed
Class A	Seal or Cover	<u>Allowed Alone or in Combination</u> <sup>5/</sup> : Gravel Crushed Gravel Carbonate Crushed Stone Crystalline Crushed Stone Crushed Sandstone Crushed Slag (ACBF) Crushed Steel Slag Crushed Concrete

**CHARLES AVENUE IMPROVEMENTS  
VILLAGE OF VILLA PARK**

Use	Mixture	Aggregates Allowed
HMA Low ESAL	Stabilized Subbase Shoulders or	<u>Allowed Alone or in Combination</u> <sup>5/</sup> : Gravel Crushed Gravel Carbonate Crushed Stone Crystalline Crushed Stone Crushed Sandstone Crushed Slag (ACBF) Crushed Steel Slag <sup>1/</sup> Crushed Concrete
HMA High ESAL Low ESAL	Binder IL-19.0 or IL-19.0L  SMA Binder	<u>Allowed Alone or in Combination</u> <sup>5/ 6/</sup> : Crushed Gravel Carbonate Crushed Stone <sup>2/</sup> Crystalline Crushed Stone Crushed Sandstone Crushed Slag (ACBF) Crushed Concrete <sup>3/</sup>
HMA High ESAL Low ESAL	C Surface and Binder IL-9.5 or IL-9.5L  SMA Ndesign 50 Surface	<u>Allowed Alone or in Combination</u> <sup>5/</sup> : Crushed Gravel Carbonate Crushed Stone <sup>2/</sup> Crystalline Crushed Stone Crushed Sandstone Crushed Slag (ACBF) Crushed Steel Slag <sup>4/</sup> Crushed Concrete <sup>3/</sup>
HMA High ESAL	D Surface and Binder IL-9.5  SMA Ndesign 50 Surface	<u>Allowed Alone or in Combination</u> <sup>5/</sup> : Crushed Gravel Carbonate Crushed Stone (other than Limestone) <sup>2/</sup> Crystalline Crushed Stone Crushed Sandstone Crushed Slag (ACBF) Crushed Steel Slag <sup>4/</sup> Crushed Concrete <sup>3/</sup>
		<u>Other Combinations Allowed:</u>
		<i>Up to...</i> <i>With...</i>
		25% Limestone                      Dolomite
		50% Limestone                      Any Mixture D aggregate other than Dolomite

**CHARLES AVENUE IMPROVEMENTS  
VILLAGE OF VILLA PARK**

Use	Mixture	Aggregates Allowed	
		75% Limestone	Crushed Slag (ACBF) or Crushed Sandstone
HMA High ESAL	E Surface IL-9.5  SMA Ndesign 80 Surface	<u>Allowed Alone or in Combination</u> <sup>5/ 6/</sup> :	
		Crystalline Crushed Stone Crushed Sandstone Crushed Slag (ACBF) Crushed Steel Slag  No Limestone.	
		<u>Other Combinations Allowed:</u>	
		<i>Up to...</i>	<i>With...</i>
		50% Dolomite <sup>2/</sup>	Any Mixture E aggregate
75% Dolomite <sup>2/</sup>	Crushed Sandstone, Crushed Slag (ACBF), Crushed Steel Slag, or Crystalline Crushed Stone		
75% Crushed Gravel <sup>2/</sup> or Crushed Concrete <sup>3/</sup>	Crushed Sandstone, Crystalline Crushed Stone, Crushed Slag (ACBF), or Crushed Steel Slag		
HMA High ESAL	F Surface IL-9.5  SMA Ndesign 80 Surface	<u>Allowed Alone or in Combination</u> <sup>5/ 6/</sup> :	
		Crystalline Crushed Stone Crushed Sandstone Crushed Slag (ACBF) Crushed Steel Slag No Limestone.	
		<u>Other Combinations Allowed:</u>	
		<i>Up to...</i>	<i>With...</i>
		50% Crushed Gravel <sup>2/</sup> , Crushed Concrete <sup>3/</sup> , or Dolomite <sup>2/</sup>	Crushed Sandstone, Crushed Slag (ACBF), Crushed Steel Slag, or Crystalline Crushed Stone

**CHARLES AVENUE IMPROVEMENTS  
VILLAGE OF VILLA PARK**

- 1/ Crushed steel slag allowed in shoulder surface only.
- 2/ Carbonate crushed stone (limestone) and/or crushed gravel shall not be used in SMA Ndesign 80. In SMA Ndesign 50, carbonate crushed stone shall not be blended with any of the other aggregates allowed alone in Ndesign 50 SMA binder or Ndesign 50 SMA surface.
- 3/ Crushed concrete will not be permitted in SMA mixes.
- 4/ Crushed steel slag shall not be used as leveling binder.
- 5/ When combinations of aggregates are used, the blend percent measurements shall be by volume."
- 6/ Combining different types of aggregate will not be permitted in SMA Ndesign 80."

**GROUND TIRE RUBBER (GTR) MODIFIED ASPHALT BINDER (D-1)**

Effective: June 26, 2006

Revised: April 1, 2016

Add the following to the end of article 1032.05 of the Standard Specifications:

"(c) Ground Tire Rubber (GTR) Modified Asphalt Binder. A quantity of 10.0 to 14.0 percent GTR (Note 1) shall be blended by dry unit weight with a PG 64-28 to make a GTR 70-28 or a PG 58-28 to make a GTR 64-28. The base PG 64-28 and PG 58-28 asphalt binders shall meet the requirements of Article 1032.05(a). Compatible polymers may be added during production. The GTR modified asphalt binder shall meet the requirements of the following table.

<b>Test</b>	<b>Asphalt Grade GTR 70-28</b>	<b>Asphalt Grade GTR 64-28</b>
Flash Point (C.O.C.), AASHTO T 48, °F (°C), min.	450 (232)	450 (232)
Rotational Viscosity, AASHTO T 316 @ 275 °F (135 °C), Poises, Pa·s, max.	30 (3)	30 (3)
Softening Point, AASHTO T 53, °F (°C), min.	135 (57)	130 (54)
Elastic Recovery, ASTM D 6084, Procedure A (sieve waived) @ 77 °F, (25 °C), aged, ss, 100 mm elongation, 5 cm/min., cut immediately, %, min.	65	65

Note 1. GTR shall be produced from processing automobile and/or light truck tires by the ambient grinding method. GTR shall not exceed 1/16 in. (2 mm) in any dimension and shall contain no free metal particles or other materials. A mineral powder (such as talc) meeting the requirements of AASHTO M 17 may be added, up to a maximum of four percent by weight of GTR to reduce sticking and caking of the GTR particles. When tested in accordance with Illinois modified AASHTO T 27, a 50 g sample of the GTR shall conform to the following gradation requirements:

**CHARLES AVENUE IMPROVEMENTS  
VILLAGE OF VILLA PARK**

<b>Sieve Size</b>	<b>Percent Passing</b>
No. 16 (1.18 mm)	100
No. 30 (600 μm)	95 ± 5
No. 50 (300 μm)	> 20

Add the following to the end of Note 1. of article 1030.03 of the Standard Specifications:

“A dedicated storage tank for the Ground Tire Rubber (GTR) modified asphalt binder shall be provided. This tank must be capable of providing continuous mechanical mixing throughout by continuous agitation and recirculation of the asphalt binder to provide a uniform mixture. The tank shall be heated and capable of maintaining the temperature of the asphalt binder at 300 °F to 350 °F (149 °C to 177 °C). The asphalt binder metering systems of dryer drum plants shall be calibrated with the actual GTR modified asphalt binder material with an accuracy of ± 0.40 percent.”

Revise 1030.02(c) of the Standard Specifications to read:

“(c) RAP Materials (Note 5) .....1031”

Add the following note to 1030.02 of the Standard Specifications:

Note 5. When using reclaimed asphalt pavement and/or reclaimed asphalt shingles, the maximum asphalt binder replacement percentage shall be according to the most recent special provision for recycled materials.

**PAY ITEM SPECIAL PROVISIONS**

**PAY ITEMS #1&2 – TREE STUMP REMOVAL**

**Description.** This work shall consist of removing existing tree stumps. Tree stumps shall be existing trees that measure less than 4.5 feet in height from the highest ground around the tree. This work shall be in accordance with Section 201 of the Standard Specifications.

**Method of Measurement.** This work will be measured for payment per each tree. The unit diameter will be measured at the top of the stump cut-off.

**Basis of Payment.** This work will be paid for at the contract unit price per each for TREE PRUNING.



**CHARLES AVENUE IMPROVEMENTS  
VILLAGE OF VILLA PARK**

**PAY ITEM #9 – EXPLORATION TRENCH, SPECIAL**

**Description.** This work shall consist of constructing a trench for the purpose of locating and inspecting an existing utility or utilities. This work shall be in accordance with Section 213 of the Standard Specifications, except as modified herein.

The exploration trench may be used to locate any existing utility or utilities including, but not limited to, water mains, water services, sewer mains, sewer services, field tiles, gas lines, underground electric lines, underground telephone lines, underground cable TV lines, underground communication lines, underground fiber optic lines, and other utilities as applicable.

The exploration trench may be used to locate existing utilities regardless of whether the utilities are public or private; known or unknown; or marked or unmarked. The exploration trench may also be used to inspect the condition of existing utilities, determine the material type or dimensions of existing utilities, and to verify clearances between multiple utilities.

The exploration trench shall be constructed at the locations shown on the plans or as directed by the Engineer. The depth of the exploration trench shall vary as necessary, but shall be sufficient to locate the utility or utilities under investigation. The width of the trench shall be sufficient to allow proper investigation of the entire trench.

Upon completion of the exploration trench, the trench shall be backfilled. All exploration trenches where the inner edge of the trench is within 2 feet of an existing or proposed edge of pavement, driveway, curb, gutter, curb and gutter, stabilized shoulder, or sidewalk shall be backfilled with trench backfill in accordance with Section 208 of the Standard Specifications. Exploration trenches which do not require trench backfill shall be backfilled in accordance with Article 550.07 of the Standard Specifications. Backfilling of exploration trenches will not be measured for payment but shall be included in the cost of this work.

**Method of Measurement.** The exploration trench will be measured for payment in feet of actual trench constructed, regardless of the depth of the trench constructed. No additional measurement or compensation will be allowed for any delays or unforeseen circumstances arising from this work.

**Basis of Payment.** This work will be paid for at the contract unit price per foot for EXPLORATION TRENCH, SPECIAL.

**CHARLES AVENUE IMPROVEMENTS  
VILLAGE OF VILLA PARK**

**PAY ITEM #10 – EARTH EXCAVATION**

**202.04 Classification: Add the following;**

Stripping of existing top soil will be paid for as EARTH EXCAVATION.

**PAY ITEM #14 – TRIAXIAL, GEOGRID REINFORCEMENT**

**Description.** The geogrid shall be composed of a single layer and shall be integrally formed with triangular apertures and high-profile ribs exhibiting significant dimensional stability through all ribs and junctions of the geogrid structure. The geogrid shall maintain its reinforcement and aggregate confinement capabilities under repeated dynamic loads while in service. The geogrid shall also be resistant to ultraviolet degradation, damage under normal construction practices, and all forms of biological and chemical degradation normally encountered in road construction. Geogrid layers shall be placed as directed by the Engineer.

**Submittals:**

Submit representative geogrid product sample.

Submit geogrid product data sheet and certification from the Manufacturer that the geogrid product supplied meets the requirements of Part 3 of this Section.

Submit Manufacturer’s installation instructions and general recommendations.

**Materials:**

The geogrid shall be integrally formed through punching and drawing of extruded sheets of polypropylene. The geogrid shall be oriented in three substantially equilateral directions so the resulting ribs have a high degree of molecular orientation that continues at least in part through the mass of the integral node.

The resulting geogrid structure shall have apertures that are triangular in shape, and shall have ribs with depth-to-width ratios greater than 1.0.

The geogrid shall have typical characteristics shown in the following table, and shall be certified in writing by the manufacturer to meet these characteristics.

<b>Properties</b>	<b>Longitudinal</b>	<b>Diagonal</b>	<b>General</b>
Rib Pitch <sup>(2)</sup> , mm (in)	60 (2.40)	60 (2.40)	
Rib Shape			rectangular
Aperture Shape			triangular
Junction Efficiency <sup>(3)</sup> , %			93

**CHARLES AVENUE IMPROVEMENTS  
VILLAGE OF VILLA PARK**

<b>Properties</b>	<b>Longitudinal</b>	<b>Diagonal</b>	<b>General</b>
Isotropic Stiffness Ratio <sup>(4,9)</sup>			0.6
Overall Flexural Rigidity <sup>(5)</sup> , mg-cm			2,000,000
Radial stiffness at low strain <sup>(6,9)</sup> , kN/m @ 0.5% strain (lb/ft @ 0.5% strain)			350 (23,989)
Resistance to chemical degradation <sup>(6)</sup>			100%
Resistance to ultra-violet light and weathering <sup>(7)</sup>			70%

1. Unless indicated otherwise, values shown are minimum average roll values (MARVs) determined in accordance with ASTM D4759-02. Brief descriptions of test procedures are given in the following notes.
2. Nominal dimensions.
3. Load transfer capability determined in accordance with ASTM D6637-10 and ASTM D7737-11 and expressed as a percentage of ultimate tensile strength.
4. The ratio between the minimum and maximum observed values of radial stiffness at 0.5% strain, measured on rib and midway between rib directions.
5. Determined in accordance with ASTM D7748-12.
6. Radial stiffness is determined from tensile stiffness measured in any in-plane axis from testing in accordance with ASTM D6637-10.
7. Resistance to loss of load capacity or structural integrity when subjected to chemically aggressive environments in accordance with EPA 9090 immersion testing.
8. Resistance to loss of load capacity or structural integrity when subjected to 500 hours of ultraviolet light and aggressive weathering in accordance with ASTM D4355-05.
9. Isotropic stiffness ratio and radial stiffness values at 0.5% strain are both preliminary estimates and are subject to change.

**Submittals:** Submit geogrid product data sheet and certification from the Manufacturer that the geogrid product supplied meets all the requirements of section C. A minimum of one material sample may be selected at random from the material delivered and tested for compliance with the requirements of section C. Each sample size required shall be a minimum of three feet wide with a one square yard minimum area.

**Alternate Structural Geogrid Materials:**

Alternate geogrid materials may be considered if they meet or exceed the design criteria of the project. Such materials must be preapproved in writing by Engineer.

CHARLES AVENUE IMPROVEMENTS  
VILLAGE OF VILLA PARK

For alternate geogrid materials not meeting all the requirements of section C, alternate material packages must be submitted meeting or exceeding the design criteria of the project to the Engineer and must include, as a minimum, the following:

- 1) Full-scale laboratory testing and in-ground testing of pavement structures reinforced with the specific geogrid, which quantifies the structural contribution (i.e., Traffic Benefit Ratio, TBR) of the geogrid with the respective aggregate. The TBR is defined as "The ratio of the number of load cycles of a reinforced pavement structure to reach a defined failure state, to the number of load cycles for the same unreinforced pavement structure to reach the same defined failure state". The alternate geogrid must meet or exceed the TBR value of the design geogrid.
- 2) Independent certified test results stating that the alternate geogrid exhibits a junction Efficiency of 98 percent or greater determined in accordance with GRI-GG2-87 and GRI-GG1-87 and expressed as a percentage of ultimate tensile strength.
- 3) A sample of the alternate geogrid material and certified specification sheets, recommended installation instructions, and additional information as requested by the Engineer to fully evaluate the application.
- 4) For the alternate geogrid material, the Manufacturer shall submit stamped and sealed engineering calculations by an experienced Geotechnical Engineer licensed in the State of Illinois. The following calculations shall be performed for up to three separate locations as directed by the Engineer: 1. Subgrade Improvement Data Input Criteria; 2. Design Output Results; 3. Supporting Hand Calculations; 4. Summary of Design Methodology Used in Calculations; 5. Validation of design as the design criteria shall follow typical IDOT and FHWA standards.

Delivery, Storage and Handling:

Storage and Protection:

- (1) Prevent excessive mud, wet concrete, epoxy or other deleterious materials from coming in contact with and affixing to the geogrid materials
- (2) Store at temperatures above -20 degrees F (-29 degrees C).
- (3) Rolled materials may be laid flat or stood on end.
- (4) Geogrid materials should not be left directly exposed to sunlight for more than 6 months or as recommended by the manufacturer.

Examination: Contractor shall check the geogrid upon delivery to verify the proper material has been received. The geogrid shall be inspected by the Contractor to be free of flaws or damage occurring during manufacturing, shipping or handling.

CHARLES AVENUE IMPROVEMENTS  
VILLAGE OF VILLA PARKExecution:

Preparation: The subgrade soil shall be prepared as indicated on the construction drawings or as directed by the Engineer.

## Installation:

- (1) The geogrid shall be installed at the proper elevation and alignment as shown on the construction drawings.
- (2) The geogrid shall be installed in accordance with these drawings and specifications and any installation guidelines provided by the manufacturer or as directed by the Engineer.
- (3) The geogrid may be temporarily secured in place with ties, staples, pins, sand bags, or backfill as directed by the Engineer.
- (4) Aggregate shall be placed and compacted in accordance with IDOT Standard Specifications for Construction. Aggregate shall be placed, spread, and compacted in such a manner that minimizes the development of wrinkles in the geogrid and/or movement of the geogrid.
- (5) A minimum loose aggregate thickness of 6 inches is required prior to operation of tracked vehicles over the geogrid. Turning of tracked vehicles should be kept to a minimum to prevent tracks from displacing the aggregate base material and damaging the geogrid. When underlying subgrade is trafficable with minimal rutting, rubber-tired equipment may pass directly over the geogrid reinforcement at slow speeds (less than 5 mph). Sudden braking and sharp turning movements shall be avoided.

## Inspection and Repair:

- (1) Owner or Owner's representative may randomly inspect geogrid before, during, and after (using test pits) installation.
- (2) Any damaged or defective geogrid (i.e. frayed coating, separated junctions, separated layers, tears, etc.) shall be repaired by removal of affected area and patching using new material with a minimum 3-foot overlap beyond the limits of the affected area.
- (3) Any roll of geogrid damaged before, during, or after installation shall be replaced by the Contractor at no additional cost to Owner.

**Method of Measurement and Basis of Payment:** This work will be measured and paid for at the contract unit price per square yard for TRIAXIAL, GEOGRID REINFORCEMENT. No allowance will be made for overlap, splices, or material cut off or wasted. The cost shall include furnishing the material, labor, and equipment required to



CHARLES AVENUE IMPROVEMENTS  
VILLAGE OF VILLA PARK**PAY ITEMS #28, 29, & 30 – TEMPORARY ACCESS**

This work shall be in accordance with Section 400 of the Standard Specifications, the details in the drawings, and the following special provision.

This work consists of the installation and removal of temporary ramps at all intersections and driveways in the total reconstructed areas. The width of the ramps shall match the street and driveway widths. The installation of the ramps shall be installed within the time constraints as follows:

- A. Intersection Ramps—By 5:00 P.M. of the same day after commencing the pavement removal at each intersection.
- B. Driveway Ramps—By 5:00 P.M. of the same day after commencing pavement removal contiguous to each driveway.

Revise Article 402.10 of the Standard Specifications to read:

**“402.10 For Temporary Access.** The contractor shall construct and maintain aggregate surface course for temporary access to private entrances, commercial entrances and roads according to Article 402.07 and as requested by the Engineer.

The aggregate surface course shall be constructed to the dimensions and grades specified below, except as modified by the plans or as requested by the Engineer.

- (b) Private Entrance. The minimum width shall be 12 feet (3.6 m). The minimum compacted thickness shall be 6 inches (150 mm). The maximum grade shall be eight percent, except as required to match the existing grade.
- (b) Commercial Entrance. The minimum width shall be 24 feet (7.2 m). The minimum compacted thickness shall be 9 inches (230 mm). The maximum grade shall be six percent, except as required to match the existing grade.
- (c) Road. The minimum width shall be 24 feet (7.2 m). The minimum compacted thickness shall be 9 inches (230 mm). The grade and elevation shall be the same as the removed pavement, except as required to meet the grade of any new pavement constructed.

Maintaining the temporary access shall include relocating and/or regrading the aggregate surface coarse for any operation that may disturb or remove the temporary access. Same type and gradation of material used to construct the temporary access shall be used to maintain it.

When use of the temporary access is discontinued, the aggregate shall be removed and utilized in the permanent construction or disposed of according to Article 202.03.”

**CHARLES AVENUE IMPROVEMENTS  
VILLAGE OF VILLA PARK**

Add the following to Article 402.12 of the Standard Specifications:

“If a residential drive, commercial entrance, or road is to be constructed under multiple stages, the temporary ramp needed to construct the second or subsequent stages will not be measured for payment.”

Revise the second paragraph of Article 402.13 of the Standard Specifications to read:

“Aggregate surface course for temporary access will be paid for at the contract unit price per each for TEMPORARY ACCESS (PRIVATE ENTRANCE), TEMPORARY ACCESS (COMMERCIAL ENTRANCE), or TEMPORARY ACCESS (ROAD).

Partial payment of the each amount bid for temporary access, of the type specified, will be paid according to the following schedule:

- (a) Upon construction of the temporary access, 60 percent of the contract unit price per each, of the type constructed, will be paid.
- (b) Subject to the approval of the Engineer for the adequate maintenance and removal of the temporary access, the remaining 40 percent of the pay item will be paid upon the permanent removal of the temporary access.”

**PAY ITEM #36 – BITUMINOUS MATERIALS (TACK COAT)**

**Description.** This work shall consist of the preparation and application of bituminous tack coat on concrete or HMA bases prior to HMA placement. This work shall be in accordance with Section 406 of the Standard Specifications, except as modified herein.

Bituminous tack coat shall be placed at least one hour in advance of the placement of HMA, but no more than 48 hours in advance of the placement of HMA. If Contractor places tack coat more than 48 hours in advance of the placement of HMA, the tack coat will not be measured for payment, and Contractor will place tack coat again in accordance with this provision. Tack coat shall not be placed on weekends or on holidays unless permitted by the Engineer. Tack coat shall not be placed before weekends or holidays when placement of HMA is not expected to take place until after the weekend or holiday, unless permitted by the Engineer.

**Basis of Payment.** This work will be paid for at the contract unit price per pound for BITUMINOUS MATERIALS (TACK COAT).

CHARLES AVENUE IMPROVEMENTS  
VILLAGE OF VILLA PARK**PAY ITEMS #37 & #38 – HOT-MIX ASPHALT DRIVEWAY PAVEMENT, 4” AND 6”**

**Description.** This work shall be in accordance with Section 355 and 406 of the Standard Specifications, the details in the drawings, and the following special provision.

Hot-mix asphalt driveways shall be constructed on a compacted 6-inch-thick (residential /private entrance) or 8-inch-thick (commercial entrance) layer of granular subbase stone having a gradation of CA-6. The cost of the subbase stone shall be included in the cost of this pay item.

This work shall be constructed in two lifts for 4-inch and 6-inch thickness. The lifts shall be composed of Hot-Mix Asphalt Surface Course, IL-9.5, Mix “D”, N50.

**Method of Measurement.** Hot-Mix Asphalt driveway pavement will be measured for payment in place and the area computed in square yards. Subbase granular material will not be measured for payment.

**Basis of Payment.** This work will be paid for at the contract unit price per square yard for HOT-MIX ASPHALT DRIVEWAY PAVEMENT, of the thickness specified which price shall be payment in full for constructing this item as specified, including all saw cutting, bituminous materials (prime coat), and subbase granular material.

**PAY ITEMS #40 & #41 – PORTLAND CEMENT CONCRETE DRIVEWAY PAVEMENT**

**Description.** This work shall consist of constructing Portland cement concrete driveway pavement on a prepared subgrade. This work shall be in accordance with Section 351 and Section 423 of the Standard Specifications, except as modified herein.

Portland cement concrete driveway pavement shall be constructed on a prepared base of mechanically compacted crushed aggregate of CA-6 gradation having a minimum compacted thickness of 4-inch-thick (residential /private entrance) or 6-inch-thick (commercial entrance). The cost of the subbase stone shall be included in the cost of this pay item.

**Method of Measurement.** Portland cement concrete driveway pavement will be measured for payment in place and the area computed in square yards. Subbase granular material will not be measured for payment.

**Basis of Payment.** This work will be paid for at the contract unit price per square yard for PORTLAND CEMENT CONCRETE DRIVEWAY PAVEMENT, of the thickness specified including saw cutting and the subbase granular material.

CHARLES AVENUE IMPROVEMENTS  
VILLAGE OF VILLA PARK**PAY ITEM #45 – DETECTABLE WARNINGS**

**Description.** This work shall consist of installing detectable warnings. This work shall be in accordance with Section 424 of the Standard Specifications, except as modified herein.

Detectable warnings shall be installed at curb ramps and other locations where pedestrians are required to cross a hazardous vehicular way. Detectable warnings shall also be installed at alleys and commercial entrances where permanent traffic control devices are present.

**Materials.** Detectable warnings shall be precast tiles. Installation shall be cast-in-place. Surface mounted applications will not be permitted. Detectable warnings shall be red in color. Detectable warning tiles shall be either rectangular or radial in shape as shown on the plans or as directed by the Engineer. The product or products to be used for detectable warnings shall be approved by the Engineer prior to use.

**Construction.** Installation shall be according to the manufacturer's specifications and as directed by the Engineer.

Where a curb ramp is 5 feet in width or less and a rectangular detectable warning tile is to be used, the installation shall consist of a single detectable warning tile. If a precast detectable warning tile is not manufactured in the width of the curb ramp, a larger detectable warning tile shall be furnished and shall be cut to the width of the curb ramp.

Installation of multiple detectable warning tiles at a single curb ramp will only be permitted where a curb ramp exceeds 5 feet in width or where radial detectable warning tiles are to be used. Where multiple detectable warning tiles are permitted at a single curb ramp, they shall be mechanically joined prior to installation.

**Method of Measurement.** Detectable warnings will be measured for payment in place and the area computed in square feet.

**Basis of Payment.** This work will be paid for at the contract unit price per square foot for DETECTABLE WARNINGS.

**PAY ITEM #50 – CLASS D PATCHES**

**Description.** This work shall consist of the removal of the existing pavement, the necessary excavation, and the replacement with hot-mix asphalt (HMA) patches at designated locations. This work shall be in accordance with Section 442 of the Standard Specifications, except as modified herein.

Remove all references to a specified type or types of patches in the Standard Specifications.

CHARLES AVENUE IMPROVEMENTS  
VILLAGE OF VILLA PARK

All patches shall be saw cut full-depth prior to removal of the existing pavement. Saw cuts shall be completed no more than three days prior to removal of the existing pavement. Saw cuts will not be paid for separately, but shall be included in the cost of this work.

Where patches are to be resurfaced with a subsequent lift of hot-mix asphalt, the patches shall be constructed with Hot-Mix Asphalt Binder Course, IL-19.0, N50. The minimum thickness of each lift shall be 2.25 inches. The maximum thickness of each lift shall be 4 inches.

Where patches are not to be resurfaced with a subsequent lift of hot-mix asphalt, the topmost lift of the patch shall be constructed with Hot-Mix Asphalt Surface Course, Mix "D", N50. The thickness of the surface course lift shall be 2 inches. Lower lifts shall be constructed with Hot-Mix Asphalt Binder Course, IL-19.0, N50. The minimum thickness of each lower binder course lift shall be 2.25 inches. The maximum thickness of each lower binder course lift shall be 4 inches.

**Basis of Payment.** This work will be paid for at the contract unit price per square yard for CLASS D PATCHES, of the thickness specified.

**PAY ITEMS #56, #57, #58, & #59 – STORM SEWERS, CLASS A**

**Description.** This work shall consist of installing storm sewers in accordance with Section 550 of the Standard Specifications, with the following modifications:

**Materials.** The kinds of materials permitted for "CLASS A" storm sewers shall only be reinforced concrete sewer pipe. The designation of "type" which refers to the fill height over the top of the pipe will not be classified in the plans. Instead, the Contractor shall use the rims and inverts provided in the plans to determine the appropriate fill height and strength class of reinforced concrete pipe according to ASTM C76 and Article 550.03 of the Standard Specifications. Should a run of pipe encounter multiple fill heights over the pipe, the more conservative strength class shall be used for the entire pipe run.

**Basis of Payment.** When CLASS A storm sewers are specified, this work will be paid for at the contract unit price per foot for STORM SEWERS, CLASS A, of the diameter specified.

**PAY ITEM #60 –PVC PIPE DRAINS SDR 26 ASTM D-2241, 6"**

**Description.** This work shall consist of providing and installing pipe, fittings and couplings; connections to manholes; all material and equipment; sawcutting; excavation; sheeting, shoring, and dewatering; by-pass pumping; removal and disposal of excavated material; bedding and covering of pipe; making connections between different pipe

CHARLES AVENUE IMPROVEMENTS  
VILLAGE OF VILLA PARK

materials; backfilling with granular trench backfill material; and any other labor and/or materials required to complete the work as specified herein.

The sewers shall be PVC SDR 26 ASTM D-2241 pipe. Fittings shall meet the requirement of ASTM D-3212 and ASTM F477. The above pipe and fittings shall be furnished with elastomeric gasket joints conforming to ASTM D-3139. Connection to existing service sewer mains and services shall be made with No-Shear Flex Coupling with two stainless steel bands at a point where the coupling cannot shift. Bedding material shall conform to IDOT gradations CA-7 or CA-11.

**Basis of Payment.** This work will be paid for at the contract unit price per lineal foot as PVC PIPE DRAINS SDR 26 ASTM D-2241, 6”

**PAY ITEM #61 & #62 – STORM SEWERS, WATER MAIN QUALITY PIPE**

Effective: February 1, 1996

Revised: January 1, 2007

This work consists of constructing storm sewer and private storm sewer services adjacent to or crossing a water main, at the locations shown on the plans. The material and installation requirements shall be according to the latest edition of the “Standard Specifications for Water and Sewer Main Construction in Illinois”, and the applicable portions of Section 550 of the Standard Specifications; which may include concrete collars and encasing pipe with seals if required.

Pipe materials shall meet the requirements of Sections 40 and 41-2.01 of the Water and Sewer Specifications, allowing the use of both polyvinyl chloride (PVC) pipe and ductile iron pipe. If ductile iron pipe is used, it shall meet the minimum requirements for Thickness Class 52.

If PVC pipe is used, it shall have a Standard Dimension Ratio (SDR) of 26 conforming to ASTM D2241 with gasket joints conforming to ASTM D3212. All supplied pipes and fittings must be from the same manufacturer. Connections to existing sewer lines shall be made using non-shear Fernco RC Series or Mission Flex-Seal adjustable repair couplings equipped with stainless steel bands.

PVC pipe shall be used for all private storm sewer services and shall meet the requirements listed above.

Encasing of standard type storm sewer, according to the details for “Water and Sewer Separation Requirements (Vertical Separation)” in the “STANDARD DRAWINGS” Division of the “Standard Specifications for Water and Sewer Main Construction in Illinois”, may be used for storm sewers crossing water mains.

CHARLES AVENUE IMPROVEMENTS  
VILLAGE OF VILLA PARK

**Basis of Payment:** This work will be paid according to Article 550.10 of the Standard Specifications, except the pay item shall be STORM SEWERS, WATER MAIN QUALITY PIPE, of the diameter specified.

**PAY ITEM #63 - STORM SEWER REMOVAL**

**Description.** This work shall be in accordance with Section 551 of the Standard Specifications, the details in the drawings, and the following special provision.

**Method of Measurement.** All storm sewer removal shall be measured for payment in place per foot regardless of size, location, or material. Any excavation required to remove the storm sewer shall be included in the cost of this pay item. The trench shall be backfilled with trench backfill material.

**Basis of Payment.** This work shall be paid for at the contract unit price per foot for STORM SEWER REMOVAL, which price shall include all materials, labor, trench backfill, and equipment necessary to complete the work as specified.

**PAY ITEM #64 AND #65 – DUCTILE IRON WATER MAIN****DUCTILE IRON WATER MAIN**

Add the following to Article 561.01

**Description.** This work shall be in accordance with Sections 20, 40, 41, and standard drawings of the SSWSC, and 561 of the Standard Specifications, the details in the plans, and the following special provision.

**562.02 Materials.** Materials shall meet the specifications of Section 40 of the SSWSC and the following;

CHARLES AVENUE IMPROVEMENTS  
VILLAGE OF VILLA PARK

## 40-2.01 PIPE MATERIALS

Add the following paragraph to this section:

All pipe and materials used in performance of the work shall be clearly marked as to strength, class, or grade. Pipe and materials not so marked shall be subject to rejection.

40-2.01B DUCTILE IRON PIPE

Replace this section with the following:

All water main pipe shall be ductile iron, minimum Class 52 standard thickness, designed in accordance with ANSI/AWWA C151/A21.51, or as required by ANSI/AWWA C150/A21.50 for various depths. All joints shall be gasketed bell and spigot type push-on Tyton joints accordance with ANSI/AWWA C111/A21.11. Interior and exterior of pipe shall have a bituminous coating, as specified in AWWA C151. Inner surfaces of all ductile iron water piping shall have a cement mortar lining in accordance with the requirements of AWWA C104. Type of pipe shall be clearly marked on pipe by manufacturer.

In cases where corporation stops are to be tapped into mains, pipe wall thickness shall be furnished as specified in AWWA C151 to provide engagement of four threads.

## 40-2.05A CAST IRON OR DUCTILE IRON PIPE FITTINGS

Replace this section with the following:

All standard water main pipe fittings sizes 3 inches through 24 inches shall be ductile iron Class 350 psi conforming to requirements of ANSI/AWWA C110/A21.10 and ANSI/AWWA C153/21.53. All water main fittings shall have a cement mortar lining in accordance with the requirement of ANSI/AWWA C104/A21.4. Fittings shall be furnished with a rated working pressure of 150 psi. All fitting joints shall be mechanical joint.

“MEGALUG®” retainers shall be used at all connections of water mains to bends, tees, crosses, reducers, and other fittings. All mechanical joints shall have a minimum of six (6) “Sac-Nuts”.

Special fittings shall be furnished and installed as shown on the plans and as specified. CONTRACTOR shall be responsible for furnishing and installing all fittings necessary to construct the water main and appurtenances in the locations shown in the plans at the specified depth of bury and for making all necessary connections to existing mains.

All bolts, tie rods, nuts, washers, and other hardware and fasteners to be installed below grade shall be stainless steel. Bolts and tie rods shall be Type 304 stainless steel. Nuts and washers shall be Type 300 stainless steel.

**CHARLES AVENUE IMPROVEMENTS  
VILLAGE OF VILLA PARK**

**41-2.02 EXCAVATION, BACKFILL, AND CLEAN UP DEPTH OF PIPE COVER**

Replace the second paragraph with the following:

The minimum depth of cover for water main and water service lines shall be 5.5 feet below existing ground or the proposed grade to the crown of the pipe. The depth shall be increased as shown on the plan and profile sheets or as necessary to avoid conflict with other utilities at no change in bid price. Deviation from grade shall not exceed ±0.1 foot. Special care shall be taken with regard to grade in the vicinity of existing and planned utility crossings.

**41-2.04 LAYING OF PIPE ON CURVES**

Add the following paragraph to this section:

No additional payment will be allowed for water main fittings. The cost of all water main fittings shall be considered incidental to the cost of the water main piping.

**41-2.10 THRUST BLOCKING**

Replace the first, second, and sixth paragraphs in this section with the following:

Water main shall be installed in accordance with AWWA C600 for iron pipe. All plugs, caps, tees, hydrants, bends, and other fittings for water mains shall be provided with restrained joints.

The minimum length of pipe to be restrained shall be as shown in the following table:

Fitting	Minimum Length - Ft
90 Degree Bend (6 inches)	19
90 Degree Bend (8 inches)	25
45 Degree Bend (6 inches)	8
45 Degree Bend (8 inches)	11
22 1/2 Degree Bend (6 inches)	4
22 1/2 Degree Bend (8 inches)	5
11 1/4 Degree Bend (6 inches)	2
11 1/4 Degree Bend (8 inches)	3
Fire Hydrant Leads	All Joints
End of Line Tees (6 inches)*	16 (Along Branch)
End of Line Tees (8 inches)*	37 (Along Branch)
Reducer 8x6 inches	38 (Along Larger Side)
45 Degree Vertical Offset (6 inches)**	28 (Upper) / 4 (Lower)
45 Degree Vertical Offset (8 inches)**	37 (Upper) / 6 (Lower)
22 1/2 Degree Vertical Offset (6 inches)**	14 (Upper) / 2 (Lower)

**CHARLES AVENUE IMPROVEMENTS  
VILLAGE OF VILLA PARK**

22 1/2 Degree Vertical Offset (8 inches)**	18 (Upper) / 3 (Lower)
11 1/4 Degree Vertical Offset (6 inches)**	7 (Upper) / 1 (Lower)
11 1/4 Vertical Offset (8 inches)**	9 (Upper) / 2 (Lower)
Dead End (6 inches)	68
Dead End (8 inches)	89

\*Restrained run length on tees assumed 5 feet on each side of fitting.

\*\*Low side depth of vertical offsets assumed to be 10 feet.

This table assumes horizontal orientation of fittings, 150 psi test pressure plus a 100 psi water hammer allowance, poly-wrapped ductile iron pipe, and a 5-foot bury. Lengths shall be adjusted for other conditions and fittings.

Pipe restraint fittings shall be provided as follows:

For ductile iron pipe with ductile iron mechanical joints MEGALUG® Series 1100 or 1100SD, by EBAA Iron Sales, Inc.

All bolts, tie rods, nuts, washers, and other hardware and fasteners to be installed below grade shall be stainless steel. Bolts and tie rods shall be Type 304 stainless steel. Nuts and washers shall be Type 300 stainless steel.

Gaskets that include metal locking segments vulcanized into the gasket to grip the pipe to provide joint restraint are not acceptable.

**41-2.14A PRESSURE TEST**

As part of the construction, water mains shall be pressure tested in accordance with this section. All testing shall be performed before curb and gutter or other permanent type surface improvement work begins. OWNER and ENGINEER shall be notified at least 24 hours before the test. The filling of the water main shall be at a rate set by OWNER with all hydrants and whips in the open position and slowly closed in the order in which water appears. A form documenting the test procedure and results shall be signed by CONTRACTOR and OWNER’s representative witnessing the test.

All newly-laid pipe shall be subjected to a hydrostatic pressure of 150 pounds per square inch, in accordance with AWWA C-600. Duration of each pressure test shall be for a period of not less than two hours. Each pressure test shall result in less than 5 pounds per per square inch of drop over the duration of the test period. Each valved section of pipe shall be filled with water and the specified test pressure shall be applied by means of a pump connected to the pipe. Before applying the specified test pressure, all air shall be expelled from the pipe. All leaks shall be repaired until tight. Any cracked or defective pipes, fittings, valves, or hydrants discovered in consequence of this pressure test shall be removed and replaced and the test repeated until satisfactory results are obtained.

**CHARLES AVENUE IMPROVEMENTS  
VILLAGE OF VILLA PARK**

All testing shall be performed before the installation of water service lines.

All materials, work, and equipment necessary for this work shall be furnished by CONTRACTOR and considered included in the contract unit prices for water main pay items.

**41-2.15 DISINFECTION OF WATER MAIN**

Replace the first paragraph with the following:

Disinfection of the water main shall be accomplished in accordance with Illinois Environmental Protection Agency requirements. Disinfection of water main will not be paid for separately, but will be included in the contract unit prices for water main pay items.

Delete Articles 561.03(a) and 561.03(b) of the Standard Specifications and refer to Sections 20 and 41 of the SSWSC.

**562.03 General.** Add the following;

**20-1A METHOD OF PAYMENT**

Add the following section:

All trench excavation, except rock excavation as defined in Section 20-2, shall be included in the cost of the pipe or associated structure being installed and will not be measured separately for payment.

**20-2 DEFINITIONS**

Final Backfill: Final backfill shall consist of backfilling from the top of initial backfill to the natural or finished surface line or to the underside of proposed pavement base.

**20-3.01 FOUNDATION, BEDDING, AND HAUNCHING**

Replace this section with the following:

Foundation, bedding and haunching material shall be gradation CA-7 meeting the Standard Specifications.

**20-3.02 INITIAL BACKFILL**

Initial backfill material shall be gradation CA-6 meeting the requirements of the standard specifications.



**CHARLES AVENUE IMPROVEMENTS  
VILLAGE OF VILLA PARK**

Add the following to the end of this section:

**Excavation By Hand or Machine**

The elevations shown for existing work and ground are reasonably correct, but are not guaranteed to be absolutely accurate. No extras will be allowed because of variations between plans and actual grades.

The trench shall be excavated so the pipe can be laid to the alignment and depth required. The trench shall not be excavated more than 100 feet in advance of pipe laying.

Prior to all excavating, CONTRACTOR shall become thoroughly familiar with the site and site conditions.

**Deviations Occasioned by Structures or Utilities**

CONTRACTOR shall accurately locate and record abandoned and active utility lines rerouted or extended on project record plans.

**20-4.06B FINAL BACKFILL**

Add the following to the second paragraph.

Select granular backfill material shall be trench backfill meeting the requirements of the Standard Specifications.

Delete the table in paragraph (1), Method 1, and add the following to the end of this paragraph:

Consolidation shall be achieved by use of vibratory plate compactors, self-propelled hydrostatic drum compactors, or backhoe operated hydraulic compactors. The lift height shall not exceed 8 inches for vibratory plate compactors. Lift height shall not exceed the following for self-propelled hydrostatic drum compactors and backhoe operated hydraulic compactors: For loam clay soils (18 inches), for loam soils (24 inches), and for granular soils (36 inches). Smaller lift heights shall be provided as necessary to achieve the degree of compaction required.

Compaction density shall be a minimum of 95% of the maximum dry density as determined by the Modified Proctor Test (ASTM D1557).

Backfill material not meeting compaction requirements shall be recompacted by CONTRACTOR at no cost to OWNER. Cost for additional testing required on recompacted materials shall be at CONTRACTOR's expense.

**CHARLES AVENUE IMPROVEMENTS  
VILLAGE OF VILLA PARK**

Delete Methods 2 and 3 in their entirety. Ponding and jetting are not acceptable methods for compaction. Trench backfill shall be compacted in accordance with Method 1.”

Add the following paragraphs to the beginning of this section:

All trenches shall be backfilled using specified material so that excessive lengths of trench are not left open. In general, the backfilling operation shall proceed so that no more than 100 feet of trench is open behind the pipe laying operation.

In all areas, the backfill shall be left below the original surface to allow for placement of crushed aggregate surfacing, plus any pavement replacement required. If settlement occurs, CONTRACTOR shall restore the surface improvements at its own expense to maintain the finished surface.

If during the progress of work, existing mains, sewer, and conduits or pipes are exposed in an unsupported condition, either the backfill beneath them shall be mechanically consolidated, or bedding material shall be placed beneath, around, and to a point six (6) inches over them to provide full support.

CONTRACTOR may backfill with the excavated material, provided that such material consists of loam clay, sand, gravel or other materials, which are suitable for backfilling.

All backfill material shall be free from cinders, ashes, refuse, vegetable or organic matter, boulders, rocks or stone, frozen lumps, or other such deleterious, unsuitable material. However, from one foot above the top of the pipe to the street subgrade, material containing stones up to eight inches in their greatest dimension may be used, unless otherwise specified.

**20-5 MEASUREMENT AND PAYMENT**

Add the following at the end of this section:

Bedding, haunching, and initial backfill for all piping on the project shall be considered included in the cost of the pipe and will not be measured separately for payment.

**20-5.03A SELECT GRANULAR BACKFILL AS INITIAL BACKFILL**

Replace this section with the following:

Regardless whether flexible or rigid pipes are used, the selected granular material required for initial backfill will not be eligible for payment but shall be considered as included in the cost of the pipe being installed.



**CHARLES AVENUE IMPROVEMENTS  
VILLAGE OF VILLA PARK**

**PAY ITEM #68 - MJ CAP**

**Description.** This work shall consist of furnishing and installing an MJ cap on water main where indicated on the drawings or directed by the Engineer. This work shall be according to the SSWSC Sections 40 and 41 and special provisions contained within this contract.

**Method of Measurement and Basis of Payment.** This work will be measured and paid for per each MJ CAP regardless of the diameter size.

**PAY ITEM #69 – FIRE HYDRANTS TO BE REMOVED**

**Description.** This work shall consist of removing fire hydrants in locations where new fire hydrants are not to be installed. This work shall be in accordance with Section 564 of the Standard Specifications and with the Standard Specifications for Water and Sewer Construction in Illinois, except as modified herein.

Where an existing fire hydrant is to be removed and replaced with a new fire hydrant in substantially the same location, removal of the existing fire hydrant will not be paid for separately but shall be included in the cost of the fire hydrant installation.

**Materials.** Water main pipe shall be ductile iron pipe conforming to ANSI/AWWA C151/A21.51, Class 52 standard thickness.

Water main couplings shall be Krausz Hymax Grip coupling restraints of the diameter required, or approved equal.

All bolts, nuts, washers, and other hardware to be installed below grade shall be Type 304 stainless steel.

**Construction.** The existing fire hydrant, auxiliary valve, valve box, hydrant lead, tee, and a portion of the adjoining water main shall be excavated and exposed. The existing water main shall be cut on both sides of the tee by an approved method and a section of existing water main shall be removed along with the tee, hydrant lead, valve box, auxiliary valve and fire hydrant. A section of new water main pipe of the proper length shall be positioned in place between the two cut ends of the existing water main and the ends of the existing water main shall be joined to the new section of water main pipe with water main couplings of the proper size.

The excavation shall be backfilled with crushed aggregate of CA-6 gradation and mechanically compacted in lifts not exceeding 12 in.

Excavation and backfilling will not be paid for separately, but shall be included in the cost of this work.

CHARLES AVENUE IMPROVEMENTS  
VILLAGE OF VILLA PARK

Fire hydrants which are removed and are selected by the Engineer to be salvaged shall remain the property of the Village and shall be delivered by the Contractor to the Village of Villa Park Public Works Department yard located at 51 South Ardmore Avenue in Villa Park. Delivery shall be made during the normal working hours of the Village of Villa Park Public Works Department and the Contractor shall coordinate the day, time and other details of delivery with the Village. Fire hydrants that are not selected by the Engineer to be salvaged shall become the property of the Contractor and shall be removed from the site by the end of the workday and properly disposed of by the Contractor. The delivery or disposal of fire hydrants will not be paid for separately but shall be included in the cost of this work.

**Basis of Payment.** This work will be paid for at the contract unit price per each for FIRE HYDRANTS TO BE REMOVED.

**PAY ITEM #70 – FIRE HYDRANT WITH AUXILIARY VALVE AND VALVE BOX**

**Description.** This work shall consist of constructing fire hydrants with auxiliary valves and valve boxes. This work shall be in accordance with Section 564 of the Standard Specifications and with the Standard Specifications for Water and Sewer Construction in Illinois, except as modified herein.

**Materials.** Fire hydrants shall be AMERICAN Flow Control 5 1/4-inch Waterous Pacer Fire Hydrant Model WB67-250, conforming to ANSI/AWWA C502, 6'-0" bury depth, with all stainless steel trim, above-ground breakable flanges, and auxiliary resilient wedge gate valve and valve box. Fire hydrants shall be fitted with DDP-arrangement nozzle sections with one 4 1/2-inch pumper nozzle and two 2 1/2-inch hose nozzles with National Standard threads and a National Standard operating nut.

Fire hydrants shall be factory painted red, prime coated with an epoxy, and finish coated with a two-part polyurethane top coat. Fire hydrants that are not factory painted red will be considered unacceptable and will be rejected.

Auxiliary valves shall be AMERICAN Flow Control Series 2500 Ductile Iron Resilient Wedge Gate Valves conforming to ANSI/AWWA C515, with mechanical joint end connections, 6-inch diameter. All exterior valve body bolting shall be Type 304 stainless steel.

Valve boxes shall have a cover embossed with the word "WATER".

Valve box adaptors shall be Adaptor, Inc., Valve Box Adaptor II (VBA-II), or approved equal.

CHARLES AVENUE IMPROVEMENTS  
VILLAGE OF VILLA PARK

Hydrant lead pipe shall be ductile iron pipe conforming to ANSI/AWWA C151/A21.51, Class 52 standard thickness, with push-on joints conforming to AWWA C111, 6-inch-diameter.

Water main couplings shall be Krausz Hymax Grip coupling restraints of the diameter required, or approved equal.

Mechanical joint restraints shall be EBAA Iron, Inc., MEGALUG Mechanical Joint Restraints for Ductile Iron Pipe, or approved equal.

Valve box stabilizer grips shall be by BLR Enterprises, Inc., or approved equal.

All hardware and fasteners to be installed below grade shall be stainless steel. Bolts and threaded rods shall be Type 304 stainless steel and nuts and washers shall be Type 300 stainless steel.

Fire hydrant barrel extensions, if permitted, shall be AMERICAN Flow Control Waterous Series and shall be a maximum of 18 inches.

Fire hydrant bags shall be polypropylene with a minimum thickness of 4 mils and orange in color with bold black print reading "NOT IN SERVICE". Bags shall include tie straps to firmly secure the bags to hydrants.

**Construction.** The fire hydrant shall be installed so that the standpipe is plumb. The center of the lowest nozzle shall be placed at least 18 inches but not more than 24 inches above finished grade. The breakable flanges shall be positioned 2 inches above finished grade. The nearest part of the hydrant shall be at least 3 feet but not more than 8 feet behind the back of curb. The nearest part of the hydrant shall be at least 3 feet from all paved surfaces. Where hydrants are to be installed adjacent to a roadway they shall be placed so that the pumper nozzle faces the roadway and is perpendicular to the direction of travel of the roadway. Where hydrants are not to be installed adjacent to a roadway they shall be placed according to the plans or as directed by the Engineer.

Fire hydrants and auxiliary valves shall be set on a firm foundation of precast concrete blocks and shall be thrust blocked. Additional precast concrete bricks shall be placed under the auxiliary valve as needed. Thrust blocking shall consist of Class SI concrete cast in place against the fittings and the undisturbed earth on any side or sides of the excavation where thrust is expected to occur. A minimum of 1/4 cu. yd. of concrete shall be used for the thrust blocking. The dimensions of the thrust blocking shall be determined by the Engineer. Thrust blocking may also consist of the placement of precast concrete blocks at the discretion of the Engineer. Additional precast concrete blocks shall be placed on the bottom, back and sides of the hydrant as directed by the Engineer to hold the hydrant solid and vertical. All blocks, bricks and thrust blocking shall be placed such that the pipe, joints and fittings shall be accessible for future repair and so that the hydrant drain holes are not blocked.

CHARLES AVENUE IMPROVEMENTS  
VILLAGE OF VILLA PARK

Mechanical joint restraints shall be installed on all mechanical fittings. Stainless steel threaded tie rods shall be installed between the fire hydrant barrel and the tee fitting on the water main. Valve box stabilizer grips shall be installed. Barrel extensions will only be permitted at the discretion of the Engineer.

Fire hydrants shall be braced and covered during backfilling. The area around the base of the hydrant shall be backfilled with a minimum of 1 cu. yd. of crushed stone aggregate of CA-1 gradation. The CA-1 aggregate shall be covered with polyethylene sheeting prior to further backfilling. Backfill material shall be placed in lifts not exceeding 6 inches in thickness, loose measurement, and compacted in a manner approved by the Engineer.

If fire hydrant or hydrant paint coat is damaged during backfilling, Contractor shall replace all damaged components at no cost to Owner. Repainting of damaged paint coat will not be permitted.

Fire hydrants not in service shall be covered with fire hydrant bags until the fire hydrants are in service.

Excavation, bedding, and backfilling of fire hydrants will not be paid for separately but shall be included in the cost of this work.

**Method of Measurement.** This work will be measured for payment as each fire hydrant with auxiliary valve and valve box installed. No separate measurement will be made of pipe, fittings, hardware, or any other components.

**Basis of Payment.** This work will be paid for at the contract unit price per each for FIRE HYDRANT WITH AUXILIARY VALVE AND VALVE BOX.

**PAY ITEM #71 & #72 – WATER SERVICE CONNECTION**

**Description.** This work shall consist of installing new copper water service connections and lines, complete in place, from the water main to the existing water service line behind the curb stop, as shown on the plans or as directed by the Engineer. This work shall be in accordance with Section 562 of the Standard Specifications and with the Standard Specifications for Water and Sewer Construction in Illinois, except as modified herein.

Short service connections shall be defined as those services for properties which are located adjacent to the half of the right-of-way where the water main is located. Long service connections shall be defined as those services for properties which are located adjacent to the half of the right-of-way opposite where the water main is located.

**Materials.** Water service line pipe shall be Type “K” seamless copper water tubing conforming to ASTM B88, of the diameter specified. The pipe shall be marked with the manufacturer’s name or trademark and with markings indicating the type of the pipe.

CHARLES AVENUE IMPROVEMENTS  
VILLAGE OF VILLA PARK

Corporation stops shall be Mueller 300 Ball Corporation Valve Model B-25000 with AWWA taper (Mueller "CC") thread inlet and copper flare straight connection outlet.

Curb stops shall be Mueller 300 Ball Curb Valve Model B-25154 with copper flare nuts on both ends, quarter turn check, and Minneapolis pattern thread top.

Water service line couplings shall be Mueller H-15400 straight three-part unions with copper flare nuts on both ends, conforming to ANSI/AWWA C800, of the size needed.

All materials furnished as a part of this work shall comply with the latest requirements of the Federal Safe Drinking Water Act.

**Construction.** Where an existing water service is to be replaced, the Contractor shall expose and remove the existing corporation stop. The Contractor shall furnish a Smith-Blair circle repair sleeve of the appropriate diameter and of sufficient length and shall install it on the water main.

Contractor shall make a new connection to the water main using a tapping machine satisfactory to the Engineer. Contractor shall furnish and install a new corporation stop of the appropriate diameter on the water main. The Engineer may require that the Contractor furnish and install a tapping sleeve of the appropriate size if needed.

Contractor shall install a new water service line pipe from the corporation stop to the location of the existing curb box, or to such other location as shown in the plans or as directed by the Engineer. A single piece of copper water tubing of sufficient length to extend the full distance from the water main to the curb stop shall be used. Splicing of multiple sections of copper water tubing will not be permitted.

The new water service line and all components shall be installed a minimum of 5.5 feet below finished grade. Where other utilities are encountered, the new water service line shall be located so that a minimum of 1 foot of clearance exists in all directions between the new water service line and all other utilities. Where the new water service line crosses other utilities, if installation of the new water service line above the utility being crossed would result in any portion of the new water service line being less than 5.5 feet below finished grade, the new water service line shall be installed below the utility being crossed.

The new water service line and all components shall be placed on a bedding of crushed aggregate of CA-7 or CA-11 gradation having a minimum thickness of 4 inches. The bedding shall be placed to a minimum of 12 inches above the water service line.

Contractor shall furnish and install a new curb stop of the appropriate diameter. Contractor shall connect the new curb stop to the existing water service line behind the curb stop. If the existing water service line behind the curb stop is of a different material or diameter than the new water service line being installed, a section of new copper water service line shall be installed behind the curb stop. The existing water service line shall

CHARLES AVENUE IMPROVEMENTS  
VILLAGE OF VILLA PARK

then be cut by an approved method, and the end of the existing water service line shall be joined to the new water service line with a water service line coupling of the appropriate type and size.

Contractor shall furnish and install a new curb box. Contractor shall remove the existing curb box. Contractor shall install a piece of lathe or timber adjacent to the new curb box to identify its location until final restoration takes place. Contractor shall adjust the new curb box to finished grade immediately before the placement of sodding or seeding, or the completion of any other final restoration measures. Contractor shall then remove the lathe or timber.

In addition to all materials listed, Contractor shall also furnish and install all other necessary fittings, adapters, hardware, and materials necessary to complete the work as described.

Excavation, bedding, backfilling, and trench backfill of water service connections and lines will not be paid for separately, but shall be included in the cost of this work.

**Method of Measurement.** This work will be measured for payment as each water service connection and line installed, regardless of the length of the water service line, the depth of the water service line, conflicts with other utilities, or any other factors. No separate measurement will be made of pipe, fittings, couplings, stops, valves, or other components.

**Basis of Payment.** This work will be paid for at the contract unit price per each for WATER SERVICE CONNECTION (LONG), of the diameter specified, or WATER SERVICE CONNECTION (SHORT), of the diameter specified.

**PAY ITEM #73 – WATER SERVICE CURB BOX**

**Description.** This work shall consist of furnishing and installing water service curb boxes. This work shall be in accordance with Section 561, Section 562, Section 563, and Section 565 of the Standard Specifications and with the Water and Sewer Specifications, except as modified herein.

This work may consist of either the standalone installation of a water service curb box on an existing water service, or the installation of a water service curb box on a new water service in conjunction with the installation of the new water service.

**Materials.** Curb boxes shall be Mueller extension type curb box Model H-10302 with Minneapolis pattern base, 1-½ in. inside diameter, and 2-½ in. base tapping diameter.

All bolts, tie rods, nuts, washers, and other hardware and fasteners to be installed below grade shall be stainless steel. Bolts and tie rods shall be Type 304 stainless steel. Nuts and washers shall be Type 300 stainless steel.

CHARLES AVENUE IMPROVEMENTS  
VILLAGE OF VILLA PARK

All materials furnished as a part of this work shall comply with the latest requirements of the Federal Safe Drinking Water Act.

**Construction.** The water service curb box shall be placed on a bedding of crushed aggregate of CA-7 or CA-11 gradation having a minimum thickness of 4 in. The bedding shall be placed to a minimum of 12 in. above the water service line and fittings.

Contractor shall furnish and install a new curb box. Contractor shall remove the existing curb box if present. Contractor shall install a piece of lath or timber marked with blue paint adjacent to the new curb box to identify its location until final restoration takes place. Contractor shall adjust the new curb box to finished grade immediately before the placement of sodding or seeding, or the completion of any other final restoration measures. Contractor shall remove the lath or timber after the completion and acceptance of final restoration measures.

Excavation, bedding, and backfilling will not be paid for separately but shall be included in the cost of this work.

**Method of Measurement.** This work will be measured for payment as each water service curb box installed, regardless of the depth of the connection, the number or type of fittings required, or any other factors. No separate measurement will be made of fittings, couplings, hardware, or any other components.

**Basis of Payment.** This work will be paid for at the contract unit price per each for WATER SERVICE CURB BOX.

**PAY ITEM #74 & #75 – CONNECTION TO EXISTING WATER MAIN**

**Description.** This work shall consist of making non-pressure, cut-in connections to existing water mains. This work shall be in accordance with Section 561 and Section 563 of the Standard Specifications and with the Standard Specifications for Water and Sewer Construction in Illinois, except as modified herein.

**Materials.** Water main pipe shall be ductile iron pipe conforming to ANSI/AWWA C151/A21.51, Class 52 standard thickness, with push-on joints conforming to AWWA C111, of the diameter required.

Water main fittings shall be ductile iron conforming to ANSI/AWWA C110/A21.10 or ANSI/AWWA C153/A21.53. Fittings shall be cement mortar lined and tar-coated in accordance with AWWA C104. Fittings shall have mechanical joint end connections unless otherwise specified. Fittings shall include tees, crosses, reducers, and all other fittings as may be necessary to construct a connection to an existing water main.

CHARLES AVENUE IMPROVEMENTS  
VILLAGE OF VILLA PARK

Water main couplings shall be Krausz Hymax Grip coupling restraints of the diameter required, or approved equal.

Mechanical joint restraints shall be EBAA Iron, Inc., MEGALUG Mechanical Joint Restraints for Ductile Iron Pipe, or approved equal.

All bolts, nuts, washers, and other hardware to be installed below grade shall be Type 304 stainless steel.

**Construction.** The connection to the existing water main shall be accomplished by the use of fittings of the proper types and sizes, sections of new water main pipe of the proper lengths and diameters, water main couplings of the proper sizes, and mechanical joint restraints. The connection shall be made in the most direct configuration possible. The connection may be made to the existing water main or to existing valves or fittings.

Thrust blocking of all fittings shall be in accordance with Article 41-2.08 of the Water and Sewer Specifications and the details in the plans.

The water main pipe and fittings shall be placed on a bedding of crushed aggregate of CA-7 or CA-11 gradation having a minimum thickness of 4 inches. The bedding shall be placed to a minimum of 12 inches above the water main pipe and fittings.

Excavation, bedding, and backfilling will not be paid for separately but shall be included in the cost of this work.

**Method of Measurement.** This work will be measured for payment as each connection made, regardless of the depth of the connection, the number or type of fittings required, or any other factors. No separate measurement will be made of removal and disposal of existing water main pipe, or new pipe fittings, couplings, hardware, or any other components. Where an existing cross is being removed and replaced with a tee fitting or an existing tee fitting is removed and replaced with a straight piece, this work shall be measured for payment as one connection to the existing water main.

**Basis of Payment.** This work will be paid for at the contract unit price per each for CONNECTION TO EXISTING WATER MAIN, of the diameter specified.

**PAY ITEM #77 & #78 – VALVE VAULT**

**Description.** This work consists of furnishing and installing a valve vault with a type 1 frame, closed lid. The work shall be in accordance with Sections 42, 44, and standard drawings of the SSWSC, and the following special provision.

## 44-3.01 VALVE VAULTS OR CHAMBERS

Add the following to this section:

**CHARLES AVENUE IMPROVEMENTS  
VILLAGE OF VILLA PARK**

Valve vaults shall be of precast reinforced concrete conforming to ASTM C-478.

For 6-, 8-, 10-, and 12-inch- diameter valves, valve vaults shall have a 48-inch inside diameter. No more than two precast concrete adjusting rings with 12 inches total maximum height shall be allowed for adjustment of each valve vault casting.

Valve vaults requiring offset cones shall be positioned so that neither the inside of cone nor the manhole steps will interfere with the operation of the valve.

When either groundwater or surface water is present in manhole excavations, it shall be removed to a level at least four inches below the bottom of the precast or poured-in-place bottom and 4 inches of bedding material shall be installed. The manhole excavation shall be leveled to provide a firm foundation for precast bottoms.

Manhole frame and cover shall be Type 1 frames and closed lids shall be Neenah R 1713 self-sealing or approved equal, embossed "WATER" and "VILLAGE OF VILLA PARK."

Manhole steps shall be EJ 8518 or steel reinforced plastic conforming to OSHA standards, 16 inches on center. The top step shall be located 10 inches or less from the top of the cone section. Manhole steps shall be inserted in manhole riser, cone, and flat slab sections prior to initial set of the concrete in accordance with ASTM C-478, and shall have maximum embedment and pull-out resistance in accordance with ASTM C-478.

**Method of Measurement and Basis of Payment:** Valve vaults shall be measured and paid for at the contract unit price per each VALVE VAULT of the vault diameter specified.

## **PAY ITEM #79 – WATER VALVES**

**Description.** This work shall consist of constructing water valves. This work shall be in accordance with applicable portions of Section 561 of the Standard Specifications and with the Standard Specifications for Water and Sewer Construction in Illinois, except as modified herein.

**Materials.** Water valves shall be AMERICAN Flow Control Series 2500 Ductile Iron Resilient Wedge Gate Valves conforming to ANSI/AWWA C515, with mechanical joint end connections, of the diameter specified, or approved equal. All exterior valve body bolting shall be Type 304 stainless steel.

Water main pipe shall be ductile iron pipe conforming to ANSI/AWWA C151/A21.51, Class 52 standard thickness, with push-on joints conforming to AWWA C111.

Water main couplings shall be Krausz Hymax Grip coupling restraints of the diameter required, or approved equal.



CHARLES AVENUE IMPROVEMENTS  
VILLAGE OF VILLA PARK**PAY ITEM #81 - STEEL CASING PIPE IN TRENCH**

**Description.** This work shall be in accordance with Sections 20, 23, and the standard drawings of the SSWSC and 550 of the Standard Specifications, and the following special provision. This work shall consist of installing a steel casing pipe in trench around a new water main, sanitary sewer, or storm sewer where indicated on the plans.

**Materials.** The steel casing pipe shall have a wall thickness designed for the anticipated loads it will experience and meet the requirements as noted in Section 23-3.02B of the SSWSC.

**Construction Method.** The carrier pipe is to be placed inside the steel casing pipe with prefabricated spacers or on hardwood blocks which are shaped to fit both the steel casing pipe and carrier pipe. At least two spacers or blocks shall be provided for each length of rigid pipe and three spacers or blocks for flexible pipe. They shall be banded to the barrel of the carrier pipe so they are parallel to the longitudinal centerline.

After the installation of the steel casing pipe, the annular space between the steel casing pipe and the carrier pipe shall be filled with blown pea gravel. In all cases, the ends of the casing pipe shall be sealed with brick and mortar, concrete, or synthetic seals specifically made for this purpose.

Bedding, haunching, and initial backfill for the steel casing pipe shall be well compacted gradation CA-6 aggregate, which shall extend from six inches below the bottom of casing to 12 inches above the top of casing.

**Method of Measurement and Basis of Payment.** This work will be measured and paid for at the contract unit price per foot of STEEL CASING PIPE IN TRENCH of the diameter specified. This price shall include steel casing pipe, welding of joints, pipe spacers, pea gravel, brick and grout, excavation, sheeting, bracing, shims, chocks, lubricants, disposal of surplus materials, bedding, haunching, initial backfill and other miscellaneous items and labor needed to complete the work as specified.

Payment for the carrier pipe to be placed inside of casing pipe shall be made separately at the unit bid price for the carrier pipe.

**PAY ITEMS #82, #83, & #84 – SANITARY SEWER, REMOVE AND REPLACE**

**Description.** This work shall consist of removing and replacing sanitary sewers by removing and replacing segments designated by the Engineer. Multiple repairs and replacements may exist throughout multiple segments of sanitary sewers ranging from a minimum repair length of 5 feet to the length required by the Engineer. This item shall also include the reconnection of existing services, the reconnection of new sewer pipe with existing sewer pipe, and the connection of the new sewer pipe to the existing

CHARLES AVENUE IMPROVEMENTS  
VILLAGE OF VILLA PARK

manhole, including outside drop connection. All work shall be performed in accordance with Sections 208, 550, and 563 of the Standard Specifications and Section 20, 30, 31, and 40 of the Water and Sewer Specifications, with the following modifications:

Any reference made to storm sewers in Section 550 of the Standard Specifications shall also apply to sanitary sewers and services described herein.

**Materials.** Sanitary sewer shall be polyvinyl chloride (PVC) pipe with a Standard Dimension Ratio (SDR) of 26 conforming to ASTM D2241 with gasket joints conforming to ASTM D3212. All supplied pipes and fittings must be from the same manufacturer. Connections to existing sewer lines shall be made using non-shear Fernco RC Series or Mission FlexSeal adjustable repair couplings equipped with stainless steel bands. PVC tee and bends used for the drop connection shall be compatible for use with the sewer pipe.

The reconnection of existing services shall be done with a new PVC wye or tee fitting which will be fabricated to fit the main and the branch service pipe. All supplied fittings and connections must be from the same manufacturer. All connections to existing pipes shall be made with non-shear Fernco RC Series or Mission Flex–Seal adjustable repair couplings equipped with stainless steel bands.

Solvent cemented joints shall not be allowed. All joints on PVC sewer shall be flexible elastomeric seal type with bells and spigots conforming to AWWA C-900. Gaskets shall conform to ASTM F-477. All bells shall be formed integrally with the pipe and shall contain a factory-installed elastomeric gasket which is positively restrained.

**Flow Control.** Prior to beginning any work that would interrupt existing flows, Contractor and Engineer will determine whether temporary plugging of the sewer line may be an acceptable alternative to bypass pumping of flows during this work. If Contractor opts to use plugging for flow control, Contractor assumes all responsibility for the consequences, and shall be solely liable for the cost of all clean-up and any other damages that may be sustained by property owners and tenants, stemming from sewer backups determined to be the result of, or attributable to, this work. Contractor shall monitor upstream conditions of the plugged sewer frequently, and shall take all action necessary to minimize surcharge conditions.

Where plugging is determined not to be prudent, bypass pumping shall be used for flow control. It may be necessary to divert all or a portion of the wastewater flow to a downstream manhole. The manner and method proposed to be employed by Contractor for bypass pumping (including a plan for all additional traffic control and protection which may be necessary) shall be reviewed and approved by Engineer prior to setting up the pumping operation. Bypassed flows from the sanitary sewer shall not be discharged to a storm sewer or overland.

CHARLES AVENUE IMPROVEMENTS  
VILLAGE OF VILLA PARK

Existing service lines to be abandoned shall have the end blocked and filled with 3 feet of concrete.

**Method of Measurement.** Bypass pumping, testing, and televising will not be measured for payment but shall be considered as included in the cost of this item.

**Basis of Payment.** This work will be paid for at the contract unit price per foot for SANITARY SEWER, REMOVE AND REPLACE, 6-INCH DIAMETER OR LESS and SANITARY SEWER, REMOVE AND REPLACE, OVER 6-INCH DIAMETER. SANITARY SEWER SERVICE CONNECTION, REMOVE AND REPLACE will be measured for payment per each connection removed and replaced with a wye fitting. REMOVE EXISTING SANITARY SEWER CONNECTION AND ABANDON IN PLACE will be measured for payment per each connection removed and abandoned. The price for all pay items shall include furnishing all materials, labor, and equipment for the complete installation of sewers and appurtenances as shown and specified. This shall include the pipe, excavation, dewatering, bedding, laying, jointing, haunching, initial backfilling, final backfilling, temporary surface, sewer bypass pumping, concrete for abandonment, disposal of materials, and connection to an existing structure as required for complete compliance with these specifications. CCTV and deflection testing shall be included in the price of the sanitary sewer.

Payment for changes in quantities shown in the Bid and Contract shall be made in accordance with the unit prices bid. No change of grade, alignment, or location shall annul or impair the Contract made and entered into relative to said work. Payment shall be made for the quantities of each bid item as actually installed. In the event it is necessary or desirable to change the grade and depth of main or appurtenances, the unit price bid shall apply to depth as actually constructed. No more than 90% of the value of work included in the unit price for sewer construction shall be eligible for inclusion in a partial payment estimate until leakage and deflection tests have been performed and the pipe and joints are found to be satisfactory.

**PAY ITEM #86 - ABANDON EXISTING COMBINED SEWER**

**Description.** This work shall consist of abandoning the existing combined sewer where shown on the plans.

The existing combined sewer to be abandoned shall be cut and blocked on both open ends. Prior to blocking, the sewer shall be filled with controlled low strength material. The excavated trench shall be backfilled with trench backfill according to Section 208. The blocked ends of the sewer shall then be filled with 3 feet of concrete. No abandonment shall take place until the all rehabilitation improvements have been performed on the existing combine sewer main that is not scheduled for abandonment.

CHARLES AVENUE IMPROVEMENTS  
VILLAGE OF VILLA PARK

**Method of Measurement and Basis of Payment.** Abandoning existing combined sewer shall be measured and paid for at a lump sum for ABANDON EXISTING COMBINED SEWER. The price shall include all labor, equipment, and materials necessary to complete the work including excavation, removals, controlled low strength material, and caps. Surface restoration will be paid for separately.

**PAY ITEM #87 - ADJUSTING SANITARY SEWER SERVICE LINES**

**Description.** This work shall be in accordance with Section 30 and 31 of the Standard Specifications for Water and Sewer Construction and 563 of the Standard Specifications, the details in the drawings, the Sanitary Sewer, Remove & Replace special provision, and the following special provision.

This work shall consist of adjusting existing sanitary sewer services lines where they conflict with the crossing of new storm sewer as determined on-site by ENGINEER. All materials shall meet the requirements of the SANITARY SEWER, REMOVE & REPLACE special provision. All fittings for vertical adjustment shall be 45-degree elbows.

**Measurement and Basis of Payment.** This work will be paid for at the contract unit price per foot for ADJUSTING SANITARY SEWER SERVICE, regardless of the diameter. The price for all pay items shall include furnishing all materials, labor, and equipment for the complete installation of sewers and appurtenances as shown and specified. This shall include the pipe, fittings, couplings, excavation, dewatering, bedding, laying, jointing, haunching, initial backfilling, final backfilling, temporary surface, disposal of materials, and connection to an existing structure as required for complete compliance with these specifications.

**PAY ITEM #88 – PROTRUDING TAP REMOVAL****PAY ITEM #89 – CIPP LINER FOR SANITARY SEWER MAIN****PAY ITEM #90 – SEWER LINING – LATERAL REINSTATEMENT****PAY ITEM #91 – SEWER ROOT FOAMING TREATMENT**

CHARLES AVENUE IMPROVEMENTS  
VILLAGE OF VILLA PARK**PAY ITEM #92 – SEWER DYE TESTING**

**Description.** The Work consists of providing all the labor, material and equipment necessary to complete the following:

1. Sewer Cleaning.
2. Sewer Root Foaming.
3. Sewer Televising.
4. Sewer Bypass Pumping.
5. Sewer Obstruction Removal.
6. Sewer Lining.
7. Sewer Lateral Inserts.

**Definitions.** The following definitions or abbreviations apply to the Work in this Division:

CCTV–closed-circuit color television

NASSCO–National Association of Sewer Service Companies

**Materials and Suppliers.** CONTRACTOR shall provide materials and supplies to satisfactorily complete the Work to the satisfaction of OWNER. Materials and supplies shall be suitable for the environment in which they are to be used or installed and shall be compatible with each other.

Suppliers shall be deemed to impliedly warrant that their products and all component materials incorporated into them are suitable and fit for the intended use of such products and shall be free from defect in material, workmanship or design, such warranty to run to the benefit of OWNER and ENGINEER. The foregoing applies whether the products or their component parts are specified in the Contract Documents or are of supplier's design.

**Water.** Water required for the Project will be provided by OWNER OR shall be provided by CONTRACTOR. CONTRACTOR shall comply with the Special Provision USE OF FIRE HYDRANTS.

**Waste Disposal.** CONTRACTOR is responsible for proper and safe disposal of all material removed from the sewers.

**Site Conditions.** CONTRACTOR is expected to examine carefully the site of the proposed Work and fully acquaint itself with the conditions as they exist to fully understand any restraints, difficulties, or other extenuating circumstances that may be present during the performance of the Work.

**Protection.** The sewers in the Project are operated and maintained by OWNER. CONTRACTOR shall perform the Work in such a manner that the operation of the existing sewers and pumping stations are not interrupted, impaired, or damaged. Existing sewers and pumping stations must be maintained in operation at all times or adequate provisions provided to convey both dry and wet weather flow. No CONTRACTOR operation shall impede the functions of the pumping station or sewer system including increasing surcharging in the system and basement backups. Any Work impacting the operation of OWNER's system shall be coordinated with OWNER.

CONTRACTOR shall assume full responsibility for any damage to adjacent lands and buildings and to the owners or occupants thereof. CONTRACTOR shall examine adjacent lands and

**CHARLES AVENUE IMPROVEMENTS  
VILLAGE OF VILLA PARK**

buildings and shall account for protection of the lands and buildings during the Work. Any damage caused shall be repaired at the expense of CONTRACTOR.

CONTRACTOR shall be aware of the attractive nuisance of the Work and make provisions for mitigating any problems.

CONTRACTOR shall take into account the impact precipitation events may have on the Work and shall schedule the Work accordingly. CONTRACTOR shall protect Work from damage caused by such events whether locally or regionally as they may impact the Work.

**Sewer Service.** It shall be CONTRACTOR’s responsibility to maintain sewer service throughout the duration of the Work. When the Work is being conducted, CONTRACTOR shall maintain sewer service by use of bypass pumping as necessary. Sewer service shall be maintained to each home or business that is connected to the sewer or manhole where the Work is being conducted. All sewers shall be kept in service when work is not being performed.

Sewage or jetting water shall not be allowed to back up into basements. CONTRACTOR shall be responsible for preventing any sewage backups into basements or cleaning impacts of such backups should they occur.

**Use of Premises.** CONTRACTOR shall confine its operations, equipment and storage areas to the existing rights-of-way and easements in which the existing sewer system is located unless OWNER and/or CONTRACTOR enters into written agreements with property owners for use of lands during construction. Such agreements shall be provided to OWNER.

**Videos.** Videos and logs are available for the sewer system. These videos are available at the office of OWNER and will be made available to CONTRACTOR.

**General Payment.** If a pay item is not provided in the Bid for an item of Work, the Work shall be considered incidental and included in adjacent or associated items of Work.

Cost for providing the following shall be considered incidental to the Work unless otherwise indicated in the Bid.

- Providing water for use in the Work.
- Removing, transporting, and disposing of material from the sewers.
- Sewer televising.
- Sewer cleaning.
- Sewer bypass pumping.

**SEWER TELEVISION**

**Description.** Providing all labor, material, and equipment necessary for the inspection of the sewers by means of closed-circuit color television (CCTV). Televising may be for OWNER’s inspection uses only or may be a part of additional Work for the Project.

**Televising.**

**Televising of Sewer Sections Not Previously Televised:**

1. Televising shall be by closed-circuit color television (CCTV).

CHARLES AVENUE IMPROVEMENTS  
VILLAGE OF VILLA PARK

2. CONTRACTOR shall clean and CCTV these lines prior to any other Work for the Project.
3. The CCTV camera shall view and video tap cuttings.
4. The section of sewer being televised shall be suitably isolated from the remainder of the sewer system as required.
5. Operator shall be NASSCO Pipeline Assessment Condition Procedure (PACP®) certified.
6. All observations and reports shall be in accordance with NASSCO PACP® standards.

Sewer isolation shall be completed during sewer televising and, unless otherwise approved in writing by OWNER, shall be by plugging off the flow of all upstream pipes through the use of sewer line plugs.

**The following procedures shall be employed, as required, to adequately complete the televising:**

1. Televising at night, and/or
2. Televising short sections of sewer and releasing the plug several times during the televising, as required.
3. Bypass pumping, where required, shall be performed by CONTRACTOR.

Equipment:

1. The color television camera used for inspection shall be specifically designed and constructed for such inspection.
2. The camera shall be operative in 100% relative humidity conditions.
3. The camera shall have a minimum of 460 horizontal resolutions.
4. Lighting for the camera shall be suitable to allow a clear picture of the entire periphery of the pipe.
5. The camera shall have a maximum 2-Lux image pick-up device.
6. The camera shall have a variable focus from the viewing operator's station.
7. The camera shall have a pan and tilt head for observing into service connections.

Procedures:

1. The camera shall be moved through the line in either direction at a uniformly slow rate by means of self-propelled equipment.
2. The speed shall not exceed 30 feet per minute, stopping to document sewer condition.
3. Direction of travel and viewing shall be downstream except where access prevents it.
4. A reverse TV setup shall be attempted, if necessary or where access prevents.
5. Measurement of defects shall be at the ground level by means of a metering device.
  - a. Marking on cable, or the like, which would require interpolation for the depth of the manhole, will not be allowed.
  - b. Measurements shall be accurate to two-tenths (0.2) of a foot.
  - c. A measuring target in front of the television shall be used as an exact measurement reference point, and the meter reading shall show this exact location of the measurement reference point.

CHARLES AVENUE IMPROVEMENTS  
VILLAGE OF VILLA PARK

- d. The measurement above ground between manholes shall be performed a minimum of twice, near the beginning of the Work and near the end of the Work, to verify the televising equipment counter accuracy.
6. Telephones or other suitable means of communication shall be set up between winches, any pumping unit, and the monitor control center.

**Record Keeping: The following information shall be noted as required for the Work:**

1. Printed records shall include the following:
  - a. Street or easement location.
  - b. Upstream and downstream manhole numbers.
  - c. Approximate depth of sewer to the nearest 0.1 foot.
  - d. Overall length of sewer.
  - e. Nominal inside diameter of sewer.
  - f. Type of sewer pipe material (include color of pipe).
  - g. Pipe joint spacing within 1/2-foot accuracy.
  - h. Unusual observations in manholes.
2. Printed location records shall be kept by CONTRACTOR that will clearly show the exact location, in relation to adjacent manholes, of each point of infiltration, inflow, or pipe defect discovered.
  - a. Defects shall be referenced according to a clockwise orientation.
  - b. Where offset or sheared joints are encountered, the amount of vertical or horizontal displacements shall be noted.
  - c. Service connections shall be noted.
    - (1) Wye, tee, or break-in type connection shall be noted.
    - (2) Clockwise orientation shall be noted.
    - (3) Size of pipe shall be noted.
    - (4) Presence of a plug or an active lateral pipe shall be noted.
  - d. Where cracks are observed, they shall be noted and include:
    - (1) Type of crack shall be noted.
      - (a) Longitudinal.
      - (b) Spiral.
      - (c) Circular.
      - (d) Multiple.
      - (e) Collapsed pipe.
    - (2) Displacement of any pipe or opening of crack shall be noted.
  - e. Where roots are observed, the percentage of root growth in relation to the pipe opening shall be noted.
  - f. Scale, corrosion, soap, and grease shall be noted and include:
    - (1) Heavy.
    - (2) Medium.
    - (3) Light.
    - (4) Clockwise orientation or amount of pipe wall covered.
  - g. Infiltration or inflow observed shall include:
    - (1) Clockwise orientation.
    - (2) Estimate of amount of flow in gallons per minute.
  - h. Any other unusual conditions observed shall be reported.
3. Three copies of all reports shall be provided to OWNER. For Sewer Televising of sewer sections not previously televised, reports shall be provided within one week of completion of the televising.

CHARLES AVENUE IMPROVEMENTS  
VILLAGE OF VILLA PARK

4. Two copies of each video of all sewers televised shall be provided to OWNER. For Sewer Televising of sewer sections not televised, videos shall be provided within one week of completion of the televising.
  - a. Videos shall be DVD.
  - b. Videos shall include the following information:
    - (1) Visual (on screen):
      - (a) Date of televising.
      - (b) Sewer reach between manholes.
      - (c) Direction of flow and direction of televising.
      - (d) Continuous distance along reach.
    - (2) Audio:
      - (a) Date of television inspection, operator name, name of overlying or adjacent street, and manhole numbers.
      - (b) Confirmation of sewer reach and televising direction in relation to direction of flow.
      - (c) Description of pipe size, type, and pipe joint length.
      - (d) Description and location of each service connection and pipe defect.
      - (e) Type of weather during televising.
    - (3) Printed labels on DVD container with number, Project location, date, format information, and company performing the Work.
5. A DVD record of all observations shall be provided of the televised sewers. The database contained on the DVD shall be PACP<sup>®</sup>-certified and compatible with Microsoft Access XP. Two copies of the DVDs shall be provided to OWNER.

The lateral service connections shall be televised and videoed: During initial televising to assist in determining if the service is active.

**CHARLES AVENUE IMPROVEMENTS  
VILLAGE OF VILLA PARK**

**Rehabilitation Televising:**

1. Televising, with videotaping, of sewer reaches or sections of sewer to be rehabilitated shall be performed as required by CONTRACTOR for performance of the Work. Televising and recordkeeping shall be as required by CONTRACTOR for performance of the Work.
2. Televising, with videotaping, of protruding tap cutting shall be performed wherever possible during tap cutting. Televising of the entire cutting operation will not be required. Following cutting, the tap periphery and the inside of the service lateral shall be televised and recorded.
3. Televising, with videotaping, shall be performed during chemical sealing-seal specific, chemical sealing-seal service connection, sewer lining-spot liner, and sewer lining -lateral reinstatement. televising of the entire rehabilitation operation will not be required. Televising of lateral reinstatement to observe the cutter shall be conducted.
4. Following completion of rehabilitation, CONTRACTOR shall televise and video each sewer reach where rehabilitation was completed. Record keeping shall be as specified in subpart Record Keeping.

OWNER makes no guarantee that all of the sanitary sewers to be entered are clear for the passage of a camera. The methods used for securing passage of the camera are to be at the option of CONTRACTOR and the costs shall be included in the unit bid price for Sewer Televising of sewer sections not televised or in the unit bid prices for other bid items. The cost of retrieving the television camera, under all circumstances, when it becomes lodged during inspection, shall be incidental to this portion of the Work.

**Measurement and Payment.** Sewer Televising will not be measured and paid for separately and shall be included in the cost of SEWER ROOT FOAM TREATMENT, CIPP LINER FOR SANITARY SEWER of the diameter specified, SEWER LINING-LATERAL REINSTATEMENT, and SANITARY SEWER REMOVE AND REPLACE, of the diameter specified.

**SEWER CLEANING**

**Description.** Providing all labor, material, and equipment necessary for the: cleaning of the sewer by mechanical means, removal of surface oils from the interior of the sewer, removal of manhole debris, and removal of roots where found in the sewer.

**Cleaning is for sewer televising and/or sewer rehabilitation, including:**

- (1) sewer obstruction removal,
- (2) sewer chemical sealing, and
- (3) sewer lining that may be part of the Work.

**Definitions.** All cleaning, whether classified by NASSCO as "light", "normal", or "heavy" cleaning shall be considered the same.

Work related to Sewer Cleaning includes cleaning for each reach of sewer identified by OWNER:  
 Proposed Sanitary Sewer Manhole 1 to Existing Combined Sewer Manhole 52-82  
 Existing Combined Sewer Manhole 52-82 to Existing Combined Sewer Manhole 52-24.  
 Existing Combined Sewer Manhole 52-24 to Existing Combined Sewer Manhole 52-113.

CHARLES AVENUE IMPROVEMENTS  
VILLAGE OF VILLA PARK

## Proposed Sanitary Sewer Manhole 2

General. CONTRACTOR shall provide all supervision, equipment, labor, and material necessary for the proper cleaning. Methods shall include, but not be limited to:

- Rodding.
- Bucketing.
- Brushing.
- Flushing.
- Root cutting.

OWNER makes no guarantee that all of the sanitary sewers to be entered are clear for the passage of cleaning equipment. The methods used for securing passage of the cleaning equipment are to be at the option of CONTRACTOR

Satisfactory precautions shall be taken to protect the sewer lines from damage that might be inflicted by the improper use of cleaning equipment. CONTRACTOR shall be responsible for and shall immediately repair any and all damage caused by its operations.

Selection of the cleaning equipment shall be based on the condition of the sewers at the time the Work commences.

All cleaning prior to any type of sewer rehabilitation shall be performed using methods in accordance with manufacturer's recommendations for rehabilitation equipment being used.

**Requirements & Procedures.** The equipment shall be capable of removing root growth, dirt, grease, rocks, sand, and other materials and obstructions from the sewers and manholes. If cleaning of an entire sewer reach cannot be successfully performed from one manhole, the equipment shall be set up at the other manhole and cleaning again attempted. If, again, successful cleaning cannot be performed or the equipment fails to traverse the entire sewer reach, CONTRACTOR shall remove the blockage.

**Cleanliness.** All material shall be removed that would impede sewage flow and any subsequent televising and/or rehabilitation efforts. Cleaning shall be completed by using as many passes as required to remove growth and debris to allow any such televising camera and/or rehabilitation to proceed. Cleaning shall be completed to a minimum of 95% of the original carrying capacity and as required for any future televising or rehabilitation procedures. All loose material shall be removed from the sewers. No material shall be passed downstream of the areas cleaned.

**Debris Removal and Disposal.** All water, sludge, dirt, sand, rock, roots, grease, and any other material resulting from the cleaning operation shall be removed by CONTRACTOR at the downstream manhole of the section being cleaned and properly disposed of by CONTRACTOR. Passing material from manhole section to manhole section, which could cause blockage, accumulations of sand in wet wells, or damage to pumping equipment, shall not be permitted. Under no circumstances shall sewage or solids removed from manholes and lines be dumped onto streets or into ditches, catch basins, storm drains, or sanitary sewer manholes. Chemical cleaning will not be allowed.

**Measurement and Payment.** Sewer Cleaning will not be measured and paid for separately and shall be included in the cost of SEWER ROOT FOAM TREATMENT, CIPP LINER FOR SANITARY

**CHARLES AVENUE IMPROVEMENTS  
VILLAGE OF VILLA PARK**

SEWER of the diameter specified and SANITARY SEWER REMOVE AND REPLACE, of the diameter specified. The cost of retrieving equipment under all circumstances, including when it becomes lodged, shall be incidental to the Work.

**SEWER ROOT FOAMING**

**Description.** Providing all labor, material, and equipment necessary for the chemical application of root removal foam.

Work related to Bid item Sewer Root Foaming includes root treatment for each reach of sewer identified by OWNER:

- Proposed Sanitary Sewer Manhole 1 to Existing Combined Sewer Manhole 52-82
- Existing Combined Sewer Manhole 52-82 to Existing Combined Sewer Manhole 52-24.
- Existing Combined Sewer Manhole 52-24 to Existing Combined Sewer Manhole 52-113.
- Proposed Sanitary Sewer Manhole 2.

**Root Foam Control.**

- A. Products:
  - 1. RootX™
  - 2. Razorooter™II
- B. Surfactant System:
  - 1. Shall deliver the active ingredients to the entire length of sewer and adhere to the pipe walls and to existing roots that project into the sewer.
  - 2. Shall enhance the penetration of the herbicide into the root masses.
  - 3. Shall produce a byproduct of sodium sulfamate to ensure a ready nutrient source for the living bacteria, which will accelerate the decay of dead roots.

**Sewer Root Foaming.** Necessary precautions shall be taken to protect the sewer lines from damage that might be inflicted by the improper use of cleaning or root foaming equipment. CONTRACTOR shall be responsible for and shall immediately repair any and all damage caused by its operations. Prior to root foaming, CONTRACTOR shall clean the sewer. Bypass pumping shall be provided as needed to allow the Work to proceed. Foaming Procedures:

- 1. All Work shall be performed according to label instructions and in accordance with the manufacturer's published procedures.
- 2. The chemical root control agent shall be applied by a foam dispersal unit in conjunction with a sewer water jet cleaning machine.

**Measurement for Payment and Basis of Payment.** This work will be measured and paid for at the contract unit price per foot for SEWER ROOT FOAMING. The cost of retrieving equipment under all circumstances, including when it becomes lodged, shall be incidental to the Work, and shall include all labor, materials, and equipment required to complete the Work. All costs for sewer cleaning and sewer bypass pumping prior to, during, and after root foaming shall be included in the unit price for Sewer Root Foaming.

**PROTRUDING TAP REMOVAL**

**Description.** Providing all labor, material, and equipment for removal of protruding lateral tap obstructions by hydraulic cutting.

CHARLES AVENUE IMPROVEMENTS  
VILLAGE OF VILLA PARK**Related Special Provisions:**

Sewer bypass pumping to complete the Work shall be in accordance with the Sewer Bypass Pumping special provision.

Sewer televising to complete the Work shall be in accordance with the Sewer Televising special provision.

Sewer cleaning to complete the Work shall be in accordance with Sewer Cleaning special provision.

**General:**

1. Prior to removal of each protruding lateral tap, the protruding lateral tap shall be televised. The protruding lateral tap material shall be verified.
2. Sewer cleaning to remove mineral deposits, debris, roots, grease and other material that would hinder the Work and any subsequent sewer rehabilitation Work shall be completed.
3. Bypass pumping shall be provided as needed to allow the Work to proceed.
4. Where cutting of the protruding tap obstruction can be viewed with a camera, CONTRACTOR shall televise the removal process. Where cutting of the protruding tap obstruction cannot be viewed with a camera, a chain header type hydraulic cutter shall not be used because of potential damage that may occur.

**Execution:**

1. Hydraulic cutting.
  - a. Hydraulic cutting shall always be utilized prior to any use of robotic cutting as discussed herein.
  - b. The protruding lateral tap shall be removed using a hydraulically propelled and powered drum cutter, a chain header type hydraulic cutter, or other means selected by and demonstrated by CONTRACTOR to provide satisfactory results.
    - (1) If it is determined by CONTRACTOR and verified by OWNER that the hydraulic drum cutter may cause damage to the sewer or lateral service connection, and before anticipated damage to the sewer or lateral service connection occurs, CONTRACTOR shall stop hydraulic cutting and notify OWNER of potential for damage.
    - (2) If OWNER verifies CONTRACTOR's determination of potential for damage, a robotically controlled cutter shall be used to cut the protruding tap.
  - c. Cutter diameter shall be adequate to trim the protrusions.
2. Robotic Cutting:
  - a. Where it is determined the hydraulically operated drum cutter would not effectively cut the protrusion to allow additional Work, a robotically controlled cutter may be used to trim excess material.
  - b. Where it is determined the protruding tap may cause the hydraulically operated drum cutter to deflect and cause potential damage to the sewer main material, a robotically controlled cutter may be used to trim the protruding tap.

**Method of Measurement and Basis for Payment.** This work will be measured and paid for at the contract unit price per each PROTRUDING TAP REMOVAL and shall include all labor,

**CHARLES AVENUE IMPROVEMENTS  
VILLAGE OF VILLA PARK**

materials, and equipment necessary to complete the Work. Use of a hydraulic cutter shall be assumed. A unit price for removing protruding tap obstructions with robotic cutter has not been included. This procedure is not anticipated. All costs for sewer cleaning, sewer televising, and sewer bypass pumping prior to, during, and after obstruction removal shall be included in the cost. Removal of mineral deposits, debris, roots, grease and other material that is completed during removal of protruding taps shall be considered incidental to the Work and included in adjacent or associated items of the Work. The cost of retrieving equipment under all circumstances, including when it becomes lodged, shall be incidental to the Work.

**CIPP SANITARY SEWER LINING & SEWER LINING–LATERAL REINSTATEMENT**

**Description.** Providing all labor, material, and equipment for sewer lining either by spot lining or complete lining of reaches of sewer. Work related to Sewer Lining–Full Liner includes lining entire reaches of sewer identified by OWNER plus at locations to be identified during sewer televising under this Contract for sewer sections not already televised. Work related to Sewer Lining–Lateral Reinstatement includes cutting liner to reinstate laterals after completion of lining at locations listed in the plans.

**Related Special Provisions:**

Sewer televising to complete the Work shall be in accordance with the Sewer Televising special provision.

Sewer cleaning to complete the Work shall be in accordance with the Sewer Cleaning special provision.

Sewer obstruction removal to complete the Work shall be in accordance with the Protruding Tap Removal special provision.

Sewer bypass pumping to complete the Work shall be in accordance with the Sewer Bypass Pumping special provision.

**Submittals.**

Manufacturer's material testing certification.

Liner thickness design.

**Quality Assurance.** The sewer lining supplier and installer shall have a minimum of five years of experience in liner installation. The liner fabricator shall have a minimum of five years of experience in liner fabrication. Field tests and cured specimens will be required.

**Products**

Liner

- A. This specification references American Society for Testing and Materials (ASTM) standard specifications, which are made a part of hereof by such reference and shall be the latest edition and revision thereof.
  1. F1216–Standard Practice for Rehabilitation of Existing Pipelines and Conduits by the Inversion and Curing of a Resin Impregnated Tube.
  2. D5813–Standard Specification for Cured-in-Place Thermosetting Resin Sewer Pipe.
  3. D638–Test Method for Tensile Properties of Plastics.

CHARLES AVENUE IMPROVEMENTS  
VILLAGE OF VILLA PARK

4. D790—Test Method for Tensile Properties of Unreinforced and Reinforced Electrical Plastics and Electrical Insulating Materials.
  5. C581—Standard Practice for determining Chemical Resistance of Thermosetting Resins.
  6. D2990—Standard Test Methods for Tensile, Compressive, Flexural Creep, and Creep Rupture of Plastics.
- B. Liner Reinforcing Material:
1. Liner tube shall be sewn or heat fusion-bonded to tightly fit the internal circumference of the original pipe for the entire length to be lined.
  2. Wall thickness shall be designed in conformance with ASTM F1216, Appendix X1.
  3. Tube shall be polyester felt formed into sheets of required thickness.
  4. Tube may be made of single-or multiple-layer construction, with any layer not less than 3 millimeters thick.
  5. Membranes or strips sandwiched in between layers may be included to control longitudinal stretching.
  6. Seams shall not be joined perpendicular to the longitudinal axis. Seams shall be spirally formed and sewn or heat fusion-bonded.
  7. Polyurethane membrane used during inversion of tube may be left on internal surface of liner after curing.
  8. The outside of the tube shall have markers along its full length at regular intervals not to exceed 5 feet.
- C. Resin shall conform to ASTM F1216 and D5813:
1. Polyester resin for general chemical applications shall be used, conforming to ASTM F1216, Appendix X2.
  2. Fillers, except those required for viscosity control, fire retardance, modulus enhancement, chemical resistance, or extension of pot life will not be allowed.
  3. Thixotropic agents that will not interfere with visual inspection may be added for viscosity control.
  4. Resins may contain pigments, dyes, or colorants that will not interfere with visual inspection of cured liner.
  5. Resin content shall be 10% to 15% by volume greater than the volume of felt in the liner tube.
- D. Cured liner shall conform to ASTM F1216:
1. Minimum thickness of bonded polyurethane membrane shall be per manufacturer's requirement and shall not affect structural dimension requirements of cured liner.
  2. Thickness of cured liner shall be as designed (+10% -4%) and shall not include thickness of polyurethane inner liner.
  3. Cured liner shall conform to the following structural standards:
    - a. Tensile Strength—3,000 psi (ASTM D638).
    - b. Flexural Modulus of Elasticity—400,000 psi (ASTM D790).
    - c. Flexural Strength—4,000 psi (ASTM D790).

**CHARLES AVENUE IMPROVEMENTS  
VILLAGE OF VILLA PARK**

4. Layers of cured CIPP shall be uniformly bonded. It shall not be possible to separate any two layers with a probe or knife point so that the layers separate cleanly or the probe moves freely between layers.
- E. Liner Design:
1. Existing host pipe material, size, and depth are available on televising records available for use by CONTRACTOR.
  2. Condition of host pipe is available on DVD records and reports available for use by CONTRACTOR.
  3. Existing soil conditions, types, and depth of groundwater shall be determined by CONTRACTOR.
- F. Manufacturer for Spot Liner and Full Liner shall be Insituform Technologies, Inc., National Liner, Inc., InLiner USA, Inc., or equal.

**Construction.****Televising:**

1. Prior to, during, and following sewer rehabilitation, CONTRACTOR shall televise and video the sewer.
2. Televising shall be used to verify the suitability of the pipe and connections for installing lining. Pipe and connection conditions shall conform to those published by the system manufacturer and NASSCO.

**Sewer Preparation:**

1. Sewer locations observed to be leaking during preparation for lining and that would interfere with sewer lining installation shall be sealed prior to installation of liner.
2. Sewer cleaning to remove mineral deposits, debris, roots, grease and other material that would hinder the Work shall be completed.
3. Removal of protruding taps and other obstructions shall be completed prior to installation of all liners.
4. Bypass pumping shall be provided as needed to allow the Work to proceed.

**Liner Preparation:**

1. Liner tube shall be impregnated with resin per manufacturer's requirements before proposed time of installation.
2. Storage and transport of impregnated liner:
  - a. Storage shall be out of direct sunlight.
  - b. Storage shall be below 40°F.
  - c. Transport shall be below 40°F.

**Liner Installation:**

1. Public Notification:
  - a. CONTRACTOR shall make every effort to maintain service usage throughout the duration of the Project. In the event that a service will be out of service, the maximum amount of time of no service shall be 12 hours for any property served by the sewer. A public notification program shall be implemented. CONTRACTOR shall be responsible for contacting each

**CHARLES AVENUE IMPROVEMENTS  
VILLAGE OF VILLA PARK**

- home or business connected to the sanitary sewer and informing them of the Work to be conducted, and when the sewer will be off-line.
- b. Written notice shall be delivered to each home or business affected by closed lateral service connections. The notice shall be approved by OWNER prior to delivery and shall provide:
    - (1) Description of work and schedule.
    - (2) How the Work will affect the residents, including the time when the sewer will be out of service.
    - (3) Cellular telephone number of CONTRACTOR they can call to discuss the Project or any problems that could arise.
    - (4) Personal contact and written notice shall be made by CONTRACTOR the day before the Work will commence on the reach or section of sewer affecting the residents.
    - (5) Personal contact shall be made by CONTRACTOR with any residents or businesses that cannot be reconnected within the time stated in the written notice.
2. Installation shall be by contractors certified by the liner manufacturer for installation of the liner.
    - a. Personnel installing the liner shall have been trained by the liner manufacturer.
    - b. Personnel installing the liner shall have a minimum of 2 years' experience with installing liners.
    - c. Installation of the liner shall conform to the manufacturer' printed procedures and literature.
  3. Curing:
    - a. Curing using circulated heating water or steam shall be performed after the insertion is complete.
      - (1) Curing temperature shall be as recommended by the liner manufacturer.
      - (2) Curing pressures shall be as recommended by the manufacturer.
      - (3) Cool down after heating shall be controlled.
        - (a) Temperature shall be controlled as recommended by the liner manufacturer.
        - (b) Pressures shall be maintained during cooling as recommended by the liner manufacturer.
    - b. Temperature of spot liners shall be monitored as recommended by the liner manufacturer.

Following installation of the liner and lateral reinstatement, CONTRACTOR shall televise and video the sewer to verify the Work.

**Reinstatement of Lateral Service Connections:**

1. All lateral service connections shall be identified prior to lining.
2. Lateral service connections shall be reopened without excavation utilizing a remote-controlled cutter monitored by a television camera.
3. A spare cutter plus spare key components shall be present at the site prior to lining.
4. CONTRACTOR shall be responsible for restoring/correcting, without any delay, all missed or faulty reconnections, as well as for any damage caused to buildings



CHARLES AVENUE IMPROVEMENTS  
VILLAGE OF VILLA PARK

**Execution.** The work entails utilizing dye, closed circuit televising (CCTV), and other techniques to determine how private property drains convey sanitary and storm flow into the sanitary sewer system.

The testing shall include testing of interior and exterior drains on private property. Exterior drains shall include, but not be limited to, the following areas: downspouts, window wells, yard drains, trench drains, catch basins, etc. Interior drains shall include all sink drains, showers, toilets, floor drains, and sump pumps in the basement or lowest level of the home.

The work entails scheduled entry into the home to record and determine plumbing arrangements, fixtures, drains, sumps, etc.

OWNER will provide CONTRACTOR a list of contact names and phone numbers for all homes to be tested. CONTRACTOR shall contact homeowners to arrange testing schedule.

When scheduling the Work, CONTRACTOR shall reach out to the homeowner at least two weeks ahead of time to alert them of the Work. CONTRACTOR must then give homeowners at least a 48-hour lead time before trying to schedule the Work. CONTRACTOR may contact the homeowner between 7 A.M. and 6 P.M. Tuesday through Thursday.

Weather conditions must be dry with no rainfall occurring 48 hours prior, in order for the Work to be performed.

All Work shall be performed in the presence of the ENGINEER.

A setup of a closed-circuit television camera in the sanitary main at the lateral connections in question shall be used to verify flow and estimate flow rates.

Dyed water shall be introduced into each and every drain on the lowest level of each residence and all exterior drains, while a camera is positioned in the sanitary sewer main at the sanitary sewer connections of the house being tested.

CONTRACTOR shall observe the sanitary connection for any flow of dyed water and note whether each drain or fixture does or does not discharge dyed water flow into the sanitary sewer. The house shall be identified by house number and street with a sketch of the house and the location of all drains and fixtures shown thereon. The drains and fixtures on the sketch shall be identified as contributing or not contributing dyed water into the sanitary sewer. A photograph shall be taken that clearly shows the location of the dye introduction in the context of its surroundings, so that the particular location is unmistakable. Documentation shall be provided to OWNER of active service laterals prior to any abandonment of sewer lateral connections.

**Method of Measurement and Basis for Payment.** SEWER DYE TESTING will be measured and paid for at the contract unit price per each building regardless of the number of connections a building has to the sewer. A unit price for Sewer Dye Testing shall include all material, labor, and equipment to complete the Work. The cost of retrieving equipment under all circumstances, including when it becomes lodged, shall be incidental to the Work.

CHARLES AVENUE IMPROVEMENTS  
VILLAGE OF VILLA PARK

All costs for sewer televising prior to, during, and after testing shall be included in the respective unit price for Sewer Dye Testing. All costs for sewer cleaning, sewer televising and sewer bypass pumping shall be included in the respective unit prices for SEWER DYE TESTING.

**SEWER BYPASS PUMPING**

**Description.** Providing all materials, labor, equipment, power, and maintenance necessary to perform bypass pumping while the Work is being completed.

**General.** Where required by sewage flows or inability to prevent debris from falling into the flow stream, CONTRACTOR shall bypass the sewage around the sewer sections or manholes as required to complete the Work. Precautions shall be taken when bypass pumping is required to prevent the flooding of nearby property.

Under no circumstances will the diversion or dumping of raw sewage be allowed onto the streets or into storm sewers. The bypass shall be made by plugging an existing upstream manhole and pumping the sewage into a downstream manhole or adjacent sanitary sewer system. Bypass pumping shall mean the use of pumps, tanks, hoses, and other necessary equipment to cause uninterrupted flow of sewage around the section or reach in which the Work is being accomplished.

All bypass pumping operations must be attended by personnel to prevent flooding in case of pump failure. Under no conditions shall a bypass pumping operation be left unattended. All personnel for setup, operation, and supervision of the bypass pumping equipment shall be provided as necessary.

All hoses and pumps shall be sized by CONTRACTOR to be of sufficient capacity to handle the existing sewage flow, plus additional flow that may occur during wet weather periods and during periods of high runoff. All equipment used in bypass pumping shall be operated and maintained in proper running condition at all times.

All hose connections shall be watertight and no leakage shall be allowed to the surface. Pumping system hoses and appurtenances shall be tested prior to use in the sewer system to ensure watertightness.

At the end of each working day, the reach or section being bypassed shall be placed in service and the bypass plug removed.

The pumps shall be specifically designed for sewage, capable of passing 3-inch solids.

CONTRACTOR shall satisfactorily demonstrate to OWNER that the bypass system works for at least the diurnal flow pattern before beginning any Work.

**Method of Measurement and Basis for Payment.** Sewer bypass pumping will not be measured and paid for separately but shall be included in the cost of SEWER DYE TESTING, CIPP LINER FOR SANITARY SEWER MAIN, SEWER LINING-LATERAL REINSTATEMENT, SEWER ROOT FOAM TREATMENT, CIPP LINER FOR SANITARY SEWER of the diameter specified, and SANITARY SEWER REMOVE AND REPLACE of the diameter specified. The cost of retrieving

**CHARLES AVENUE IMPROVEMENTS  
VILLAGE OF VILLA PARK**

equipment under all circumstances, including when it becomes lodged, shall be incidental to the Work.

**PAY ITEM #93 - SANITARY SEWER MANHOLE, TYPE A, 4'-DIAMETER, TYPE 1 FRAME, CLOSED LID**

**Description.** This work consists of furnishing and installing a new sanitary sewer manhole with frame and lid. This work shall be in accordance with the SSWSC and standard drawings, and the following special provision.

32-4 PRECAST MANHOLES AND STRUCTURES

Delete paragraph 2 in its entirety.

Add the following to this section:

Manholes shall be constructed with eccentric cone top sections. Where sufficient height is not available for an eccentric cone, flat slabs shall be provided.

When either groundwater or surface water is present in manhole excavations, it shall be removed to a level at least four inches below the bottom of the precast or poured-in-place bottom and 4 inches of bedding material shall be installed. The manhole excavation shall be leveled to provide a firm foundation for precast bottoms.

All pipe connection openings except for concrete storm sewer shall be precast with resilient rubber water-tight pipe to manhole sleeves or seals, per ASTM C-923. Rubber gasketed manhole coupling shall be Kor-N-Seal, A-lok, or equal.

32-4.02 EXTERNAL SEALING BANDS

Manhole frame and chimney seals shall be installed on all sanitary manholes. A rubber seal extension, to cover any additional heights of chimney not covered by the standard seal itself, shall be furnished and installed as required. The rubber seal and seal extensions shall be as manufactured by Cretex Specialty Products, Adaptor Inc., or equal.

The sleeves and extensions shall have a minimum thickness of 3/16-inch and shall be extruded or molded from a high grade rubber compound conforming to applicable requirements of ASTM C-923, with a minimum of 1,500 psi tensile strength, maximum 18% compression set, and a hardness (durometer) of 48°5.

Mechanical bands used for compressing the sleeve and extension against the manhole shall be fabricated from 16 gauge stainless steel conforming to ASTM A-240, Type 304. Any screws, bolts, or nuts used on this band shall be stainless steel conforming to ASTM F-593 and 594, Type 304.

The sleeve shall be capable of vertical expansion of not less than 2 inches when installed.

**CHARLES AVENUE IMPROVEMENTS  
VILLAGE OF VILLA PARK****32-5 MANHOLE STEPS**

Replace this section with the following:

Manhole steps shall be installed in all manholes by the manhole manufacturer. Manhole steps shall be cast iron conforming to ASTM A-48, EJ No. 8518, or M.A. Industries, Inc. PS1-PF of 1/2-inch-diameter steel reinforcing rod conforming to ASTM A-615, Grade 60, with molded copolymer propylene covering conforming to ASTM 04101, Type PP200B33450Z02.

Manhole steps shall be inserted in manhole riser, cone, and flat slab sections prior to initial set of the concrete in accordance with ASTM C-478, and shall have maximum embedment and pull-out resistance in accordance with ASTM C-478.

The top step shall be located 10 inches or less from the top of the cone section. Steps shall be a maximum 16 inches apart.

**32-8 PIPE CONNECTIONS**

Add the following to this section:

Manhole connections for sanitary sewer mains and laterals shall be made using flexible, watertight connections, A-Lok, Interpace, PS-10, KOR-N-SEAL, or equal.

**32-12 INSPECTION AND TESTING FOR ACCEPTANCE**

Add the following to this section:

All lift holes shall be plugged and any penetrations of the manhole or pipes entering the manhole shall be plugged and braced to prevent them from being drawn into the manhole. A vacuum pump capable of creating the required head condition and a pressure gauge graduated to 0.10 inch of mercury (0.10 psi) shall be used to measure vacuum pressure.

The test head shall be applied at the top of the manhole excluding casting and lid, in accordance with manufacturer's recommendations. A vacuum of 10 inches of mercury (4.90 psi) shall be drawn on the manhole and held. The time shall be measured for the vacuum to drop to 9 inches of mercury (4.41 psi).

The manhole shall pass if the time for vacuum reading to drop from 10 inches of mercury (4.90 psi) to 9 inches of mercury (4.41 psi) meets or exceeds the values in the following table:



CHARLES AVENUE IMPROVEMENTS  
VILLAGE OF VILLA PARK

**Materials.** Sewer service cleanouts shall be polyvinyl chloride (PVC) of the diameter and type required.

Sewer service cleanout riser pipes shall be polyvinyl chloride (PVC) of the diameter and type required.

Sewer service line pipe shall be polyvinyl chloride (PVC) conforming to ASTM D-2241 with a Standard Dimension Ratio (SDR) equal to 26 and gasketed joints conforming to ASTM D-3212. Sewer service line pipe shall be of the same diameter as the sewer service line on which the sewer service cleanout is to be installed. All supplied pipe shall be from the same manufacturer.

Pipe couplings shall be Fernco Shielded RC Series Couplings, Mission Rubber Company Flex-Seal ARC Sewer Repair Couplings, or approved equal. Pipe couplings shall be non-shear and shall be equipped with stainless steel bands.

**Construction.** The sewer service cleanout shall be located a minimum of 12 in. behind the back of the public sidewalk. The height of the cleanout riser pipe shall be such that the top of the sewer service cleanout is ½ in. below finished grade.

Excavation, bedding, and backfilling will not be paid for separately but shall be included in the cost of this work.

**Method of Measurement.** This work will be measured for payment as each sewer service cleanout installed, regardless of the depth, whether the cleanout is installed on an existing sewer service line or a new sewer service line, whether the cleanout is installed on a sanitary sewer service or a storm sewer service, or any other factors. No separate measurement will be made of pipe, fittings, couplings, or other components.

**Basis of Payment.** This work will be paid for at the contract unit price per each for SEWER SERVICE CLEANOUT.

**PAY ITEM #95 – SEWER SERVICE CHECK VALVE**

**Description.** This work shall consist of furnishing and installing a sewer service check valve on a new or existing sewer service line at the locations shown in the plans or as directed by the Engineer. This work shall be in accordance with Section 563 of the Standard Specifications and with the Water and Sewer Specifications, except as modified herein.

This work may consist of the standalone installation of a sewer service check valve on an existing sanitary sewer service line; the installation of a sewer service check valve on a

CHARLES AVENUE IMPROVEMENTS  
VILLAGE OF VILLA PARK

new sanitary sewer service line in conjunction with the installation of the new sanitary sewer service line; the standalone installation of a sewer service check valve on an existing storm sewer service line; or the installation of a sewer service check valve on a new storm sewer service line in conjunction with the installation of the new storm sewer service line.

**Materials.** Sewer service check valves shall be RectorSeal Clean Check Extendable Backwater Valve, 6" PVC, Model #31805, or approved equal.

Sewer service check valve riser pipes shall be polyvinyl chloride (PVC) of the diameter and type required.

Sewer service line pipe shall be polyvinyl chloride (PVC) conforming to ASTM D-2241 with a Standard Dimension Ratio (SDR) equal to 26 and gasketed joints conforming to ASTM D-3212. Sewer service line pipe shall be of the same diameter as the sewer service line on which the sewer service check valve is to be installed. All supplied pipe shall be from the same manufacturer.

Pipe couplings shall be Fernco Shielded RC Series Couplings, Mission Rubber Company Flex-Seal ARC Sewer Repair Couplings, or approved equal. Pipe couplings shall be non-shear and shall be equipped with stainless steel bands.

**Construction.** The sewer service check valve shall be located a minimum of 12 in. behind the back of the public sidewalk. Where a sewer service check valve is installed in combination with a sewer service cleanout, the sewer service cleanout shall be located a minimum of 12 in. behind the back of the public sidewalk and the sewer service check valve shall be located on the building side of the sewer service cleanout immediately upstream of the sewer service cleanout. The height of the check valve riser pipe shall be such that the top of the sewer service check valve is ½ in. below finished grade.

The check valve shall be assembled and installed in accordance with the manufacturer's specifications. Contractor shall provide all materials, fittings, and adapters necessary to assemble the check valve and to connect it to the sewer service line.

Following installation, the check valve shall be tested by the Contractor to confirm that there is positive flow through the sewer service line and check valve towards the sewer main.

Excavation, bedding, and backfilling will not be paid for separately but shall be included in the cost of this work.

**Method of Measurement.** This work will be measured for payment as each sewer service check valve installed, regardless of the depth, whether the check valve is installed on an existing sewer service line or a new sewer service line, whether the cleanout is

CHARLES AVENUE IMPROVEMENTS  
VILLAGE OF VILLA PARK

installed on a sanitary sewer service or a storm sewer service, or any other factors. No separate measurement will be made of pipe, fittings, couplings, or other components.

**Basis of Payment.** This work will be paid for at the contract unit price per each for SEWER SERVICE CHECK VALVE.

**PAY ITEM #96 – SEWER SERVICE FRAME AND LID**

**Description.** This work shall consist of furnishing and installing a frame and lid on a new or existing sewer service cleanout or on a new or existing sewer service check valve at locations where said cleanout or check valve is located within proposed pavement, at the locations shown on the plans, or as directed by the Engineer. This work shall be in accordance with Section 563 of the Standard Specifications and with the Standard Specifications for Water and Sewer Construction in Illinois, except as modified herein.

**Materials.** Sewer service frames and lids shall be Neenah R-1975-A2 or approved equal.

**Construction.** The sewer service frame and lid shall be located such that no portion of the frame when plumb is less than 12 in. from any edge of the adjacent pavement. The height of the sewer service frame and lid shall be such that the top of the sewer service frame and lid is  $\frac{1}{4}$  in. below the finished grade of the adjacent pavement.

Excavation, bedding, and backfilling will not be paid for separately but shall be included in the cost of this work.

**Method of Measurement.** This work will be measured for payment as each sewer service frame and lid installed.

**Basis of Payment.** This work will be paid for at the contract unit price per each for SEWER SERVICE FRAME AND LID.

CHARLES AVENUE IMPROVEMENTS  
VILLAGE OF VILLA PARK**PAY ITEM #97, #98, & #99 – COMBINATION CONCRETE CURB AND GUTTER, TYPE B**

**Description.** This work shall consist of constructing combination concrete curb and gutter as shown on the plans or as directed by the Engineer. This work shall be in accordance with Section 606 of the Standard Specifications, except as modified herein.

Excavation will not be paid for separately but shall be included in the cost of this item.

Combination concrete curb and gutter shall be constructed on a prepared base of mechanically compacted crushed aggregate of CA-6 gradation having a minimum compacted thickness of 4 in.

Wood forms shall be used. Forms constructed of steel or Masonite will not be permitted. Forms for radius sections of the combination concrete curb and gutter shall be constructed of 1 inch-thick wood boards.

The height of the curb head may vary as shown on the plans or as directed by the Engineer. Variations in the height of the curb head will not be paid for separately but shall be included in the cost of this item.

Where combination concrete curb and gutter is constructed across driveways, alleys, sidewalk curb ramps, or other designated areas, the top of the curb shall be depressed according to the details shown on the plans or as directed by the Engineer. The transition from full height curb to depressed curb shall be made over a distance equal to at least four times the difference in height between the full height curb and the depressed curb.

Where combination concrete curb and gutter is constructed across sidewalk curb ramps, the depressed curb shall be in compliance with all applicable requirements of the Americans with Disabilities Act (ADA) and the Proposed Guidelines for Accessible Rights-of-Way (PROWAG).

Where combination concrete curb and gutter is to be constructed adjacent to proposed sidewalk to be constructed, the combination concrete curb and gutter shall be constructed first and shall be constructed with an integral poured ledge. The ledge shall extend horizontally a minimum of 3 inches from the back of the curb head of the combination concrete curb and gutter. The ledge shall be positioned so that the vertical distance from the top of the ledge to the top of the curb head is equal to the thickness of the proposed sidewalk. The ledge shall extend vertically to the bottom edge of the combination concrete curb and gutter. The construction of the integral poured ledge will not be paid for separately but shall be included in the cost of this item.

Expansion joints shall be constructed at 60-foot maximum centers. Expansion joints shall also be constructed at all construction joints, all points of curvature, all points of tangency, within 5 feet on either side of all curb structure castings, and at additional locations as

CHARLES AVENUE IMPROVEMENTS  
VILLAGE OF VILLA PARK

directed by the Engineer. Expansion joints shall consist of a 1-inch-thick preformed bituminous expansion joint filler that extends the full cross section of the combination concrete curb and gutter. Expansion joint filler material that is larger than the cross section of the combination concrete curb and gutter shall be cut to the exact cross section of the combination concrete curb and gutter. Expansion joints shall have two 18 inch long, No. 6 non-deformed epoxy-coated steel dowel bars placed at mid-depth. The dowel bars shall have a greased plastic expansion cap placed on one end of each dowel bar a minimum of 1 inch from the end of the dowel bar.

Where proposed combination concrete curb and gutter is to be constructed abutting existing combination concrete curb and gutter, the dowel bars shall be drilled into the existing combination concrete curb and gutter. This work will not be paid for separately but shall be included in the cost of this item.

Contraction joints shall be constructed at 15-foot maximum centers. Where the location of a contraction joint coincides with the location of an expansion joint, the contraction joint may be omitted at the discretion of the Engineer. Contraction joints shall be tooled and sawed. Sawing of contraction joints shall commence as soon as the concrete has hardened sufficiently to permit sawing without excessive raveling, but in no case shall sawing commence less than 4 hours or more than 24 hours after the concrete is placed. Sawing of contraction joints shall be to a depth equal to 1/3 the thickness of the gutter flag and to a width of not less than 1/8 inch. Contraction joints shall be sealed according to Article 420.12, except that joints shall be sealed with polysulfide or polyurethane joint sealant.

If Contractor fails to construct joints in accordance with the requirements of this provision and the curb cracks, the Contractor shall remove and replace the affected section of combination concrete curb and gutter extending the full length between the two adjacent joints on either side of the crack. This work will not be paid for but shall be at the Contractor's expense.

Upon removal of the forms from the back of the combination concrete curb and gutter, excavated areas behind the combination concrete curb and gutter shall be immediately backfilled. Areas where pavement or sidewalks are to be constructed shall be backfilled with crushed aggregate of CA-6 or CA-7 gradation and mechanically compacted. Areas where topsoil and sodding are to be placed shall be backfilled with non-organic material acceptable to the Engineer. This work will not be paid for separately but will be included in the cost of this item.

**Basis of Payment.** This work will be paid for at the contract unit price per foot for COMBINATION CONCRETE CURB AND GUTTER, TYPE B-4.12, COMBINATION CONCRETE CURB AND GUTTER, TYPE B-6.12, and CONCRETE CURB, TYPE B.

**PAY ITEM #105 – TYPE 1 FRAME, CLOSED LID**

**CHARLES AVENUE IMPROVEMENTS  
VILLAGE OF VILLA PARK****PAY ITEM #106 –TYPE 11 FRAME AND GRATE****PAY ITEM #107 – TYPE 11V FRAME AND GRATE**

**Description.** This work shall consist of furnishing and placing frames, grates, lids and all other castings furnished under this contract shall be in accordance with Section 602 and Section 604 of the Standard Specifications, except as modified herein.

Castings shall conform to ASTM A48 Class 30. Castings shall be free of cracks, holes, swells, cold shuts, and patches. Castings shall not be coated or painted.

Frames, grates, lids and other castings shall be furnished in accordance with the following:

Type 1 frames and closed lids shall be Neenah R-1713 self-sealing or approved equal.

Type 1 frames and open lids shall be Neenah R-1713 or approved equal.

Type 11 frames and grates located in barrier curb and gutter and not at sag locations shall be Neenah R-3281-A with curb box or approved equal.

Type 11V frames and grates located in barrier curb and gutter at sage locations shall be Neenah R-3281-AL with curb box or approved equal.

All other castings not specified above shall be as shown on the plans or as directed by the Engineer. If any of the castings specified are not compatible in the field due to frame height or other constraints, the Contractor shall propose an alternate casting to the Engineer for approval and shall furnish the alternate casting if approved.

Frames, grates, lids, and other castings located within curb ramps or crosswalks shall be substituted with ADA-compliant castings.

All closed lid castings furnished under this contract shall be self-sealing, gasketed, watertight, and shall have machined bearing surfaces and concealed pick holes. The top surface of all closed lids shall be embossed with the words "VILLAGE OF VILLA PARK". The top surface of closed lids shall also be embossed with the word "SANITARY", "STORM", or "WATER" as appropriate.

Enviro-curb logos on curb boxes for Type 11 frames and grates shall have the words "DUMP NO WASTE" and "DRAINS TO RIVER" or "DRAINS TO WATERWAY" cast into the top of all curb boxes.



CHARLES AVENUE IMPROVEMENTS  
VILLAGE OF VILLA PARK

All valve vaults shall have a new Type 1 frame and lid, machine-framed, meeting the requirements of ASTM A-48. The lid shall have concealed pick holes. Closed lids shall be embossed "WATER" in the middle of the lid and "VILLAGE OF VILLA PARK" on the outside of the lid according to the details in the plans.

All storm manholes shall have a new Type 1 frame and lid, machine-framed, meeting the requirements of ASTM A-48. The lid shall have concealed pick holes. Closed lids shall be embossed "STORM" in the middle of the lid and "VILLAGE OF VILLA PARK" on the outside of the lid according to the details in the plans.

All inlets shall have a new Type 11V frame and grate, machine-framed, meeting the requirements of ASTM A-48.

Sanitary manholes shall be fitted with a new chimney seal of Cretex Specialty Products, Adapter, Inc. The chimney seals shall have a minimum thickness of 3/16-inch and shall be extruded or molded from a high grade rubber compound conforming to applicable requirements of ASTM C-923, with a minimum of 1,500 psi tensile strength, maximum 18% compression set, and a hardness (durometer) of 48°5.

All adjusting rings or bricks shall be removed and replaced with new precast concrete adjusting rings meeting the requirements of ASTM C-478. The use of steel "cheater" rings inside the frames shall not be allowed. No more than two adjustment rings totaling a height of 12 inches shall be used. For structures located within pavement, the top adjusting ring shall be a rubber adjustment riser, Infra-Riser.

**Method of Measurement and Basis of Payment.** This work will be measured and paid for at the contract unit price each for VALVE VAULTS TO BE ADJUSTED, DRAINAGE AND UTILITY STRUCTURES TO BE ADJUSTED, AND DRAINAGE AND UTILITY STRUCTURES TO BE RECONSTRUCTED and includes all labor, material, removal and disposal of the existing frame and lid, manhole barrel and cone sections, and existing adjustment rings, new frame and lid, chimney seal, manhole barrel and cone sections, multiple adjustments (if needed) and adjustment rings. Select structures throughout the project may have to be adjusted multiple times due to maintenance of traffic staging. Additional adjustments to structures will not be paid for separately but shall be included in the cost of the adjustment, reconstruction, or structure pay item.

Adjustment of existing water valve boxes and curb boxes/buffalo boxes will not be paid for separately and shall be included in the cost of the utility and drainage structure adjustment items.

**PAY ITEM #111 – DRAINAGE STRUCTURE TO BE REMOVED**

**Description.** This work shall be in accordance with Section 605 of the Standard

CHARLES AVENUE IMPROVEMENTS  
VILLAGE OF VILLA PARK

Specifications, the details in the drawings, and the following special provision.

**General.** This work shall consist of removing utility structures including inlets, manholes, and catch basins in accordance with Section 605 of the Standard Specifications. The void in the ground left from removing the structure shall be filled with granular backfill meeting the requirements for trench backfill.

**Method of Measurement and Basis of Payment.** This work will be measured and paid for at the contract unit price each for DRAINAGE STRUCTURE TO BE REMOVED and includes all labor, material, removal and disposal of the structure, earth excavation and trench backfill.

**PAY ITEM #112 - VALVE VAULTS TO BE ABANDONED**

**Description.** This work consists of abandoning existing water main vaults and valves inside the vault. The work shall be in accordance with the SSWSC and standard drawings, and the following special provision.

**General.** Abandonment of existing valve vaults shall be performed by removing and disposing of the top cone section or minimum top 2 feet of structure below the proposed finished grade, and filling the vault with CA-7 aggregate or sand. If the existing vault is made of other materials than precast concrete, the vault walls shall be removed to a point 2 feet below the existing surface. The ground above the filled vault shall be filled with Class CA-7 aggregate to a point at the bottom of the pavement restoration. OWNER shall have right of first refusal for all existing vault frames and lids. OWNER-rejected frames and lids shall be disposed by CONTRACTOR. No abandonment shall take place until the new main has been tested and accepted, and until all services have been connected to the new main.

**Method of Measurement and Basis of Payment.** Existing water vaults shall be measured and paid for at the contractor unit price per each VALVE VAULTS TO BE ABANDONED and shall include all labor and materials including excavation, removing parts of the vault, removing frame and lids, filling the vault with CA-7 aggregate, and placing CA-7 aggregate to the bottom of the proposed restoration. All excavation and items removed shall be properly disposed of. Surface restoration will be paid for separately.

**PAY ITEM #115 – TRAFFIC CONTROL AND PROTECTION (SPECIAL)**

**Description.** This work shall consist of the furnishing, installation, maintenance, relocation, and removal of work zone traffic control and protection. This work shall be in accordance with Section 701 of the Standard Specifications, the Supplemental Specifications, the "Illinois Manual of Uniform Traffic Control Devices", the Highway

CHARLES AVENUE IMPROVEMENTS  
VILLAGE OF VILLA PARK

Standards and details contained in the Plans and Special Provisions, and the Special Provisions contained herein, except as modified herein.

The bid price for TRAFFIC CONTROL AND PROTECTION (SPECIAL) shall not exceed 5 percent of the total bid price. If the bid price for TRAFFIC CONTROL AND PROTECTION (SPECIAL) exceeds 5 percent of the total bid price, the Village may reject the Bid.

Special Attention is called to Article 107.09 of the Standard Specifications and the following Highway Standards, Details, Recurring Local Roads and Streets Special Provisions, and Special Provisions contained herein, relating to traffic control.

HIGHWAY STANDARDS: 701001, 701006, 701101, 701106, 701602, 701701, 701301, 701501, 701801, 701901

## DETAILS:

Traffic Control and Protection for Side Roads, Intersections, and Driveways  
(TC-10)

## SPECIAL PROVISIONS (Included in these Special Provisions):

Maintenance of Roadways  
Work Zone Traffic Control Surveillance (LRS 3)  
Flaggers in Work Zones (LRS 4)  
Equipment Parking and Storage (BDE)  
Lights on Barricades (BDE)

Contractor shall contact the Village at least 72 hours in advance of beginning work. Construction operations shall be conducted in a manner such that streets shall be open to emergency traffic and accessible as required to local traffic. Advanced notice shall be provided to residents, police, fire, school districts, school bus companies, and trash haulers when access to any street will be temporarily closed or limited. Removal and replacement of curb and gutter and driveways shall be planned so as to cause a minimum of inconvenience to the abutting property owners. The work shall be accomplished such that the streets shall be left open to local traffic at the end of each workday.

**Method of Measurement.** This work will be measured for payment on a lump sum basis. No measurement will be made of any of the individual components of this work.

**Basis of Payment.** Traffic control and protection will be paid for at the contract lump sum price for TRAFFIC CONTROL AND PROTECTION (SPECIAL), which price shall include all of the above listed requirements, details, standards, and special provisions.

CHARLES AVENUE IMPROVEMENTS  
VILLAGE OF VILLA PARK**PAY ITEM #117 – PRE-CONSTRUCTION VIDEO RECORDING**

**Description.** This work shall consist of performing color video and audio recording of the project area and other areas which may be impacted by construction.

Pre-construction video recordings will include coverage of the project area and all other areas which may be impacted by construction. Video recordings will also include construction easements when applicable. Video recordings will provide a visual record of all physical features within those areas, including, but not limited to, roadways, pavements, curbs, gutters, driveways, driveway aprons, sidewalks, carriage walks, parkways, trees, landscaping, shrubbery, plantings, landscaping walls, retaining walls, signs, sign posts, fences, utility poles, light poles, utilities, equipment, manholes, b-boxes, cleanouts, valves, curb structures, pipelines, buildings, mailboxes, and any other features located within the project area.

Video recordings will begin with an audio narrative which provides the current date and time, the name of the Village and name of project, and a description of both the starting location and the location or locations to be recorded, including street name or names, street addresses, and any additional information which may be necessary to describe the location and subject of viewing.

Video recordings will maintain viewer orientation by means of an audio commentary in the audio track of each video recording which provides an explanation of what is being viewed; and by videotaping landmarks and readily identifiable objects, including property addresses, street signs, or other appropriate objects, at appropriate intervals.

Pre-construction video recordings will be recorded at a rate of travel not exceeding 50 feet per minute, and zooming and panning rates will be controlled to provide clarity of features during playback. The finished product will be provided with bright, clear pictures and accurate colors free from distortion, tearing, rolls, or other forms of picture imperfection. The audio will have proper volume and clarity. All recordings will be performed at times of satisfactory visibility, and when no more than 10 percent of ground is obscured by snow, leaves, or other cover.

If any element within or portion of the project area is not adequately documented by the pre-construction video recording so as to definitively demonstrate its condition prior to the start of construction, Contractor will assume responsibility for the repair, restoration or replacement of that element or portion of the project area. Such repair, restoration or replacement will be to equal or better condition than previously existing, and will further comply with all standards and provisions which govern the work in question.

**Schedule.** Preconstruction video recording will be performed according to the following schedule:

CHARLES AVENUE IMPROVEMENTS  
VILLAGE OF VILLA PARK

- (a) Pre-construction video recording will be completed after a Notice to Proceed has been issued.
- (b) Pre-construction video recording will be completed after the Joint Utility Locating Information for Excavators (JULIE) request for the project area has cleared.
- (c) Pre-construction video recording will be completed before any equipment, materials, or other items are delivered to the site.
- (d) Pre-construction video recording will be completed no more than 7 chargeable days prior to the start of construction.
- (e) Pre-construction video recording will be completed, the required pre-construction video recording deliverables will be submitted to the Engineer, and the Engineer will review and issue written approval of the pre-construction video recording before any activity other than utility locating will be permitted to start. Such activity will include, but not be limited to, delivery of materials and equipment, installation of traffic control and erosion control, and completion of construction layout and tree protection. No days will be charged against the contract time while the video is under review by the Engineer, including the day the deliverables are submitted and the day a response is provided. If the pre-construction video recording or any portions thereof are rejected, the contract time will commence to run until revisions are submitted.
- (f) Pre-construction video recording will be submitted to Engineer for review prior to commencement of any construction, and receive acceptance of recordings prior to commencement of construction. Any areas found not acceptable to the Owner will be re-recorded at no additional cost to the contract.

**Deliverables.** Video will be high-definition, with a minimum resolution of 1280 by 720 pixels per frame. Video will be filmed in a landscape aspect ratio. Video filmed in a portrait aspect ratio will be considered unacceptable and will be rejected.

Preconstruction video recordings will be provided as electronic files of .avi, .mp4, .m4v, .mkv, .wmv, or .mpg file format, or of such other file format as may be approved by Engineer. Preconstruction video recordings will be provided as independent digital container format files, which container files will include all video, audio, and other electronic information necessary to view the preconstruction video recording as intended.

Video DVD will be considered an unacceptable format for providing preconstruction video recordings, and will be rejected.

Pre-construction video recording electronic files will be provided on a portable electronic media device or devices of one of the following types: USB flash drive, SD flash memory

CHARLES AVENUE IMPROVEMENTS  
VILLAGE OF VILLA PARK

card, CF flash memory card, data DVD, external hard drive, or such other portable electronic media device as may be approved by Engineer. Preconstruction video recording electronic files may also be provided via online file sharing, cloud storage, File Transfer Protocol (FTP), or other online or network file transfer methods if approved by Engineer.

Pre-construction video recording electronic files will be accompanied by corresponding logs which document the dates, times, and locations covered by each preconstruction video recording electronic file.

Contractor shall maintain copies of all items submitted to Engineer for Contractor's own use and record.

**Method of Measurement.** This work will be measured for payment on a lump sum basis. No measurement will be made of the individual components of this effort.

**Basis of Payment.** Pre-construction video recording will be paid for at the contract lump sum price for PRE-CONSTRUCTION VIDEO RECORDING.

**PAY ITEM #118 – WATER USAGE DEDUCTION**

**Description.** Pay items are provided as a part of this contract for the purpose of documenting the quantity of water obtained from the Village by the Contractor.

If the Contractor elects to obtain water from the Village, the Contractor shall comply with the Special Provision USE OF FIRE HYDRANTS. The quantity of water obtained from the Village by the Contractor shall be deducted from the contract as WATER USAGE DEDUCTION, and shall be credited to the contract as WATER USAGE CREDIT.

The WATER USAGE DEDUCTION pay item for this contract has been established with a unit of measurement in thousands of gallons (TGAL), a quantity of one-hundred (100.00), and a contract unit price of a deduction of eight dollars and eighty-five cents (\$8.85), for a total WATER USAGE DEDUCTION contract price of a deduction of eight-hundred eighty-five dollars and no cents (\$885.00). Bidder, in submitting a bid, accepts the quantity, contract unit price, and total contract price of the WATER USAGE DEDUCTION pay item.

**Method of Measurement.** Water usage will be measured as the actual quantity of water obtained from the Village by the Contractor, which quantity shall be rounded up to the nearest 1,000 gallons.

**Basis of Payment.** The water usage deduction will be deducted at the contract unit price per thousand gallons (TGAL) for WATER USAGE DEDUCTION. The quantity deducted

CHARLES AVENUE IMPROVEMENTS  
VILLAGE OF VILLA PARK

as WATER USAGE DEDUCTION will be equal to the quantity paid for as WATER USAGE CREDIT.

**PAY ITEM #119 – WATER USAGE CREDIT**

**Description.** Pay items are provided as a part of this contract for the purpose of documenting the quantity of water obtained from the Village by the Contractor.

If the Contractor elects to obtain water from the Village, the Contractor shall comply with the Special Provision USE OF FIRE HYDRANTS. The quantity of water obtained from the Village by the Contractor shall be deducted from the contract as WATER USAGE DEDUCTION, and shall be credited to the contract as WATER USAGE CREDIT.

The WATER USAGE CREDIT pay item for this contract has been established with a unit of measurement in thousands of gallons (TGAL), a quantity of one-hundred (100.00), and a contract unit price of eight dollars and eighty-five cents (\$8.85), for a total WATER USAGE CREDIT contract price of eight-hundred eighty-five dollars and no cents (\$885.00). Bidder, in submitting a bid, accepts the quantity, contract unit price, and total contract price of the WATER USAGE CREDIT pay item.

**Method of Measurement.** Water usage will be measured as the actual quantity of water obtained from the Village by the Contractor, which quantity shall be rounded up to the nearest 1,000 gallons.

**Basis of Payment.** The water usage credit will be paid for at the contract unit price per thousand gallons (TGAL) for WATER USAGE CREDIT. The quantity paid for as WATER USAGE CREDIT will be equal to the quantity deducted as WATER USAGE DEDUCTION.

**PAY ITEM #120 – CONTINGENCY ALLOWANCE**

**Description.** A contingency allowance pay item is provided as a part of this contract for the purpose of facilitating the completion of unforeseen or additional work not included in the contract as awarded, and which is determined by the Engineer to be necessary and germane to the contract.

Use of the contingency allowance will be at the discretion of the Engineer. The Engineer may, at the Engineer's discretion, use the contingency allowance for any of the following reasons:

- (a) Facilitate a temporary payment allowance to the Contractor for work completed under existing contract pay items and for which completed quantities exceed contract quantities;

CHARLES AVENUE IMPROVEMENTS  
VILLAGE OF VILLA PARK

- (b) Facilitate a temporary payment allowance to the Contractor for work completed beyond the scope of existing contract pay items; or
- (c) Facilitate a temporary payment allowance to the Contractor for the purchase of equipment, materials or such other requisition as Engineer determines to be necessary for the completion of the Work.

Such use of the CONTINGENCY ALLOWANCE will be further subject to approval by the Village. The Village's decision with regard to use of the CONTINGENCY ALLOWANCE will be final.

- A. Any payments made to Contractor under the CONTINGENCY ALLOWANCE will be considered temporary, and will only be retained by Contractor until such time that an authorization of contract changes can be approved and incorporated into the contract.
- B. Contractor, in accepting payments made under the CONTINGENCY ALLOWANCE, agrees to the terms of this and other applicable special provisions. Contractor agrees to relinquish any monies and any claim to monies paid under the CONTINGENCY ALLOWANCE upon approval of an authorization of contract changes and payment for any work for which payment was previously made under the CONTINGENCY ALLOWANCE. Contractor further agrees to return any monies previously paid thereunder.
- C. The CONTINGENCY ALLOWANCE pay item for this contract has been established with a unit of measurement in dollars, a quantity of 30,000.00, and a contract unit price of one dollar (\$1.00), for a total CONTINGENCY ALLOWANCE contract price of thirty thousand dollars and no cents (\$30,000.00). Bidder, in submitting a bid, accepts the quantity, contract unit price, and total contract price of the CONTINGENCY ALLOWANCE.

**Basis of Payment.** This work will be paid for at the contract unit price per dollar for CONTINGENCY ALLOWANCE. The total bid amount for this item will be \$50,000.00.



**APPENDIX A**  
**SUPPLEMENTAL SPECIFICATIONS**

**OWNER COPY**

**CONTRACT**

INDEX  
FOR  
SUPPLEMENTAL SPECIFICATIONS  
AND RECURRING SPECIAL PROVISIONS

Adopted January 1, 2021

This index contains a listing of SUPPLEMENTAL SPECIFICATIONS and frequently used RECURRING SPECIAL PROVISIONS.

ERRATA Standard Specifications for Road and Bridge Construction (Adopted 4-1-16) (Revised 1-1-21)

SUPPLEMENTAL SPECIFICATIONS

<u>Std. Spec. Sec.</u>	<u>Page No.</u>
106 Control of Materials .....	1
107 Legal Regulations and Responsibility to Public .....	2
109 Measurement and Payment .....	3
205 Embankment .....	4
403 Bituminous Surface Treatment (Class A-1, A-2, A-3) .....	5
404 Micro-Surfacing and Slurry Sealing .....	6
405 Cape Seal .....	17
406 Hot-Mix Asphalt Binder and Surface Course .....	27
420 Portland Cement Concrete Pavement .....	28
424 Portland Cement Concrete Sidewalk .....	30
442 Pavement Patching .....	31
502 Excavation for Structures .....	32
503 Concrete Structures .....	35
504 Precast Concrete Structures .....	38
505 Steel Structures .....	40
506 Cleaning and Painting New Steel Structures .....	41
511 Slope Wall .....	42
522 Retaining Walls .....	44
542 Pipe Culverts .....	45
586 Sand Backfill for Vaulted Abutments .....	46
602 Catch Basin, Manhole, Inlet, Drainage Structure, and Valve Vault Construction, Adjustment, and Reconstruction .....	48
603 Adjusting Frames and Grates of Drainage and Utility Structures .....	49
630 Steel Plate Beam Guardrail .....	50
631 Traffic Barrier Terminals .....	53
670 Engineer's Field Office and Laboratory .....	54
701 Work Zone Traffic Control and Protection .....	55
704 Temporary Concrete Barrier .....	58
780 Pavement Striping .....	60
781 Raised Reflective Pavement Markers .....	61
783 Pavement Marking and Marker Removal .....	62
888 Pedestrian Push-Button .....	64
1001 Cement .....	65
1003 Fine Aggregates .....	66
1004 Coarse Aggregates .....	67
1006 Metals .....	70
1008 Structural Steel Coatings .....	73
1020 Portland Cement Concrete .....	77
1043 Adjusting Rings .....	79
1050 Poured Joint Sealers .....	81
1069 Pole and Tower .....	83
1077 Post and Foundation .....	84
1083 Elastomeric Bearings .....	85
1095 Pavement Markings .....	86
1096 Pavement Markers .....	87
1101 General Equipment .....	88
1102 Hot-Mix Asphalt Equipment .....	89

1103	Portland Cement Concrete Equipment .....	91
1105	Pavement Marking Equipment .....	93
1106	Work Zone Traffic Control Devices .....	95



**Check Sheet for Recurring Special Provisions**



Local Public Agency	County	Section Number
Village of Villa Park	DuPage	N/A

The Following Recurring Special Provisions Indicated By An "X" Are Applicable To This Contract And Are Included By Reference:

Recurring Special Provisions

<u>Check Sheet #</u>		<u>Page No.</u>
1	<input type="checkbox"/> Additional State Requirements for Federal-Aid Construction Contracts	97
2	<input type="checkbox"/> Subletting of Contracts (Federal-Aid Contracts)	100
3	<input type="checkbox"/> EEO	101
4	<input type="checkbox"/> Specific EEO Responsibilities Non Federal-Aid Contracts	111
5	<input type="checkbox"/> Required Provisions - State Contracts	116
6	<input type="checkbox"/> Asbestos Bearing Pad Removal	122
7	<input type="checkbox"/> Asbestos Waterproofing Membrane and Asbestos HMA Surface Removal	123
8	<input type="checkbox"/> Temporary Stream Crossings and In-Stream Work Pads	124
9	<input type="checkbox"/> Construction Layout Stakes Except for Bridges	125
10	<input checked="" type="checkbox"/> Construction Layout Stakes	128
11	<input type="checkbox"/> Use of Geotextile Fabric for Railroad Crossing	131
12	<input type="checkbox"/> Subsealing of Concrete Pavements	133
13	<input type="checkbox"/> Hot-Mix Asphalt Surface Correction	137
14	<input type="checkbox"/> Pavement and Shoulder Resurfacing	139
15	<input type="checkbox"/> Patching with Hot-Mix Asphalt Overlay Removal	140
16	<input type="checkbox"/> Polymer Concrete	142
17	<input type="checkbox"/> PVC Pipeliner	144
18	<input type="checkbox"/> Bicycle Racks	145
19	<input type="checkbox"/> Temporary Portable Bridge Traffic Signals	147
20	<b>Reserved</b>	149
21	<input type="checkbox"/> Nighttime Inspection of Roadway Lighting	150
22	<input type="checkbox"/> English Substitution of Metric Bolts	151
23	<input checked="" type="checkbox"/> Calcium Chloride Accelerator for Portland Cement Concrete	152
24	<input type="checkbox"/> Quality Control of Concrete Mixtures at the Plant	153
25	<input type="checkbox"/> Quality Control/Quality Assurance of Concrete Mixtures	161
26	<input type="checkbox"/> Digital Terrain Modeling for Earthwork Calculations	177
27	<b>Reserved</b>	179
28	<input type="checkbox"/> Preventive Maintenance - Bituminous Surface Treatment (A-1)	180
29	<b>Reserved</b>	186
30	<b>Reserved</b>	187
31	<b>Reserved</b>	188
32	<input type="checkbox"/> Temporary Raised Pavement Markers	189
33	<input type="checkbox"/> Restoring Bridge Approach Pavements Using High-Density Foam	190
34	<input type="checkbox"/> Portland Cement Concrete Inlay or Overlay	193
35	<input type="checkbox"/> Portland Cement Concrete Partial Depth Hot-Mix Asphalt Patching	197
36	<input type="checkbox"/> Longitudinal Joint and Crack Patching	200
37	<input type="checkbox"/> Concrete Mix Design - Department Provided	202

Local Public Agency

County

Section Number

Village of Villa Park

DuPage

N/A

The Following Local Roads And Streets Recurring Special Provisions Indicated By An "X" Are Applicable To This Contract And Are Included By Reference:

Local Roads And Streets Recurring Special Provisions

<u>Check Sheet #</u>		<u>Page No.</u>
LRS 1	<b>Reserved</b>	204
LRS 2	<input type="checkbox"/> Furnished Excavation	205
LRS 3	<input checked="" type="checkbox"/> Work Zone Traffic Control Surveillance	206
LRS 4	<input checked="" type="checkbox"/> Flaggers in Work Zones	207
LRS 5	<input checked="" type="checkbox"/> Contract Claims	208
LRS 6	<input checked="" type="checkbox"/> Bidding Requirements and Conditions for Contract Proposals	209
LRS 7	<input type="checkbox"/> Bidding Requirements and Conditions for Material Proposals	215
LRS 8	<b>Reserved</b>	221
LRS 9	<input type="checkbox"/> Bituminous Surface Treatments	222
LRS 10	<b>Reserved</b>	223
LRS 11	<input checked="" type="checkbox"/> Employment Practices	224
LRS 12	<input checked="" type="checkbox"/> Wages of Employees on Public Works	226
LRS 13	<input type="checkbox"/> Selection of Labor	228
LRS 14	<input type="checkbox"/> Paving Brick and Concrete Paver Pavements and Sidewalks	229
LRS 15	<input checked="" type="checkbox"/> Partial Payments	232
LRS 16	<input checked="" type="checkbox"/> Protests on Local Lettings	233
LRS 17	<input checked="" type="checkbox"/> Substance Abuse Prevention Program	234
LRS 18	<input type="checkbox"/> Multigrade Cold Mix Asphalt	235

State of Illinois  
Department of Transportation  
Bureau of Local Roads and Streets

SPECIAL PROVISION  
FOR  
INSURANCE

Effective: February 1, 2007

Revised: August 1, 2007

All references to Sections or Articles in this specification shall be construed to mean specific Section or Article of the Standard Specifications for Road and Bridge Construction, adopted by the Department of Transportation.

The Contractor shall name the following entities as additional insured under the Contractor's general liability insurance policy in accordance with Article 107.27:

Village of Villa Park

---

Strand Associates, Inc.

---

Sandra Hechler

---

Sarad Lakhani

---

---

---

---

The entities listed above and their officers, employees, and agents shall be indemnified and held harmless in accordance with Article 107.26.

BDE SPECIAL PROVISIONS  
For the July 30 and September 17, 2021 Lettings

The following special provisions indicated by a "check mark" are applicable to this contract and will be included by the Project Coordination and Implementation Section of the BD&E. An \* indicates a new or revised special provision for the letting.

File Name #	Special Provision Title	Effective	Revised
80099 1	<input type="checkbox"/> Accessible Pedestrian Signals (APS)	April 1, 2003	April 1, 2020
80274 2	<input type="checkbox"/> Aggregate Subgrade Improvement	April 1, 2012	April 1, 2016
80192 3	<input type="checkbox"/> Automated Flagger Assistance Device	Jan. 1, 2008	
80173 4	<input type="checkbox"/> Bituminous Materials Cost Adjustments	Nov. 2, 2006	Aug. 1, 2017
80426 5	<input type="checkbox"/> Bituminous Surface Treatment with Fog Seal	Jan. 1, 2020	
80436 6	<input type="checkbox"/> Blended Finely Divided Minerals	April 1, 2021	
80241 7	<input type="checkbox"/> Bridge Demolition Debris	July 1, 2009	
50261 8	<input type="checkbox"/> Building Removal-Case I (Non-Friable and Friable Asbestos)	Sept. 1, 1990	April 1, 2010
50481 9	<input type="checkbox"/> Building Removal-Case II (Non-Friable Asbestos)	Sept. 1, 1990	April 1, 2010
50491 10	<input type="checkbox"/> Building Removal-Case III (Friable Asbestos)	Sept. 1, 1990	April 1, 2010
50531 11	<input type="checkbox"/> Building Removal-Case IV (No Asbestos)	Sept. 1, 1990	April 1, 2010
80425 12	<input type="checkbox"/> Cape Seal	Jan. 1, 2020	Jan. 1, 2021
80384 13	<input checked="" type="checkbox"/> Compensable Delay Costs	June 2, 2017	April 1, 2019
80198 14	<input type="checkbox"/> Completion Date (via calendar days)	April 1, 2008	
80199 15	<input type="checkbox"/> Completion Date (via calendar days) Plus Working Days	April 1, 2008	
80293 16	<input type="checkbox"/> Concrete Box Culverts with Skews > 30 Degrees and Design Fills ≤ 5 Feet	April 1, 2012	July 1, 2016
80311 17	<input type="checkbox"/> Concrete End Sections for Pipe Culverts	Jan. 1, 2013	April 1, 2016
80261 18	<input checked="" type="checkbox"/> Construction Air Quality – Diesel Retrofit	June 1, 2010	Nov. 1, 2014
80387 19	<input type="checkbox"/> Contrast Preformed Plastic Pavement Marking	Nov. 1, 2017	
80434 20	<input type="checkbox"/> Corrugated Plastic Pipe (Culvert and Storm Sewer)	Jan. 1, 2021	
80029 21	<input type="checkbox"/> Disadvantaged Business Enterprise Participation	Sept. 1, 2000	March 2, 2019
80402 22	<input checked="" type="checkbox"/> Disposal Fees	Nov. 1, 2018	
80378 23	<input checked="" type="checkbox"/> Dowel Bar Inserter	Jan. 1, 2017	Jan. 1, 2018
80421 24	<input type="checkbox"/> Electric Service Installation	Jan. 1, 2020	
80415 25	<input type="checkbox"/> Emulsified Asphalts	Aug. 1, 2019	
80423 26	<input type="checkbox"/> Engineer's Field Office and Laboratory	Jan. 1, 2020	
80229 27	<input type="checkbox"/> Fuel Cost Adjustment	April 1, 2009	Aug. 1, 2017
80417 28	<input checked="" type="checkbox"/> Geotechnical Fabric for Pipe Underdrains and French Drains	Nov. 1, 2019	
80420 29	<input type="checkbox"/> Geotextile Retaining Walls	Nov. 1, 2019	
80433 30	<input type="checkbox"/> Green Preformed Thermoplastic Pavement Markings	Jan. 1, 2021	
80304 31	<input type="checkbox"/> Grooving for Recessed Pavement Markings	Nov. 1, 2012	Nov. 1, 2020
80422 32	<input type="checkbox"/> High Tension Cable Median Barrier	Jan. 1, 2020	Nov. 1, 2020
80416 33	<input type="checkbox"/> Hot-Mix Asphalt – Binder and Surface Course	July 2, 2019	Nov. 1, 2019
80398 34	<input type="checkbox"/> Hot-Mix Asphalt – Longitudinal Joint Sealant	Aug. 1, 2018	Nov. 1, 2019
* 80406 35	<input type="checkbox"/> Hot-Mix Asphalt – Mixture Design Verification and Production (Modified for I-FIT)	Jan. 1, 2019	July 1, 2021
80347 36	<input type="checkbox"/> Hot-Mix Asphalt – Pay for Performance Using Percent Within Limits – Jobsite Sampling	Nov. 1, 2014	July 2, 2019
80383 37	<input type="checkbox"/> Hot-Mix Asphalt – Quality Control for Performance	April 1, 2017	July 2, 2019
* 80411 38	<input type="checkbox"/> Luminaires, LED	April 1, 2019	July 1, 2021
80393 39	<input checked="" type="checkbox"/> Manholes, Valve Vaults, and Flat Slab Tops	Jan. 1, 2018	March 1, 2019
80045 40	<input type="checkbox"/> Material Transfer Device	June 15, 1999	Aug. 1, 2014
80418 41	<input type="checkbox"/> Mechanically Stabilized Earth Retaining Walls	Nov. 1, 2019	Nov. 1, 2020
80424 42	<input type="checkbox"/> Micro-Surfacing and Slurry Sealing	Jan. 1, 2020	Jan. 1, 2021
80428 43	<input type="checkbox"/> Mobilization	April 1, 2020	
80412 44	<input type="checkbox"/> Obstruction Warning Luminaires, LED	Aug. 1, 2019	
80430 45	<input type="checkbox"/> Portland Cement Concrete – Haul Time	July 1, 2020	
80359 46	<input type="checkbox"/> Portland Cement Concrete Bridge Deck Curing	April 1, 2015	Nov. 1, 2019

80431	47	<input type="checkbox"/>	Portland Cement Concrete Pavement Patching	July 1, 2020	
80432	48	<input type="checkbox"/>	Portland Cement Concrete Pavement Placement	July 1, 2020	
80300	49	<input type="checkbox"/>	Preformed Plastic Pavement Marking Type D - Inlaid	April 1, 2012	April 1, 2016
34261	50	<input type="checkbox"/>	Railroad Protective Liability Insurance	Dec. 1, 1986	Jan. 1, 2006
80157	51	<input type="checkbox"/>	Railroad Protective Liability Insurance (5 and 10)	Jan. 1, 2006	
80306	52	<input type="checkbox"/>	Reclaimed Asphalt Pavement (RAP) and Reclaimed Asphalt Shingles (RAS)	Nov. 1, 2012	Jan. 2, 2021
80407	53	<input type="checkbox"/>	Removal and Disposal of Regulated Substances	Jan. 1, 2019	Jan. 1, 2020
* 80419	54	<input checked="" type="checkbox"/>	Silt Fence, Inlet Filters, Ground Stabilization and Riprap Filter Fabric	Nov. 1, 2019	July 1, 2021
80395	55	<input type="checkbox"/>	Sloped Metal End Section for Pipe Culverts	Jan. 1, 2018	
80340	56	<input type="checkbox"/>	Speed Display Trailer	April 2, 2014	Jan. 1, 2017
80127	57	<input type="checkbox"/>	Steel Cost Adjustment	April 2, 2004	Aug. 1, 2017
80408	58	<input type="checkbox"/>	Steel Plate Beam Guardrail Manufacturing	Jan. 1, 2019	
80413	59	<input type="checkbox"/>	Structural Timber	Aug. 1, 2019	
80397	60	<input type="checkbox"/>	Subcontractor and DBE Payment Reporting	April 2, 2018	
80391	61	<input type="checkbox"/>	Subcontractor Mobilization Payments	Nov. 2, 2017	April 1, 2019
80437	62	<input type="checkbox"/>	Submission of Payroll Records	April 1, 2021	
80435	63	<input type="checkbox"/>	Surface Testing of Pavements – IRI	Jan. 1, 2021	April 1, 2021
80298	64	<input type="checkbox"/>	Temporary Pavement Marking	April 1, 2012	April 1, 2017
80409	65	<input checked="" type="checkbox"/>	Traffic Control Devices - Cones	Jan. 1, 2019	
80410	66	<input type="checkbox"/>	Traffic Spotters	Jan. 1, 2019	
20338	67	<input type="checkbox"/>	Training Special Provisions	Oct. 15, 1975	
80318	68	<input type="checkbox"/>	Traversable Pipe Grate for Concrete End Sections	Jan. 1, 2013	Jan. 1, 2018
80429	69	<input type="checkbox"/>	Ultra-Thin Bonded Wearing Course	April 1, 2020	
80288	70	<input type="checkbox"/>	Warm Mix Asphalt	Jan. 1, 2012	April 1, 2016
80302	71	<input type="checkbox"/>	Weekly DBE Trucking Reports	June 2, 2012	April 2, 2015
80414	72	<input type="checkbox"/>	Wood Fence Sight Screen	Aug. 1, 2019	April 1, 2020
80427	73	<input checked="" type="checkbox"/>	Work Zone Traffic Control Devices	Mar. 2, 2020	
80071	74	<input type="checkbox"/>	Working Days	Jan. 1, 2002	

The following special provisions are in the 2021 Supplemental Specifications and Recurring Special Provisions.

<u>File Name</u>	<u>Special Provision Title</u>	<u>New Location(s)</u>	<u>Effective</u>	<u>Revised</u>
80277	Concrete Mix Design – Department Provided	Check Sheet #37	Jan. 1, 2012	April 1, 2016
80405	Elastomeric Bearings	Article 1083.01	Jan. 1, 2019	
80388	Equipment Parking and Storage	Article 701.11	Nov. 1, 2017	
80165	Moisture Cured Urethane Paint System	Article 1008.06	Nov. 1, 2006	Jan. 1, 2010
80349	Pavement Marking Blackout Tape	Articles 701.04, 701.19(f), 701.20(j) and 1095.06	Nov. 1, 2014	April 1, 2016
80371	Pavement Marking Removal	Articles 783.02-783.04, 783.06 and 1101.13	July 1, 2016	
80389	Portland Cement Concrete	Article 1020.04 Table 1 and Note 4	Nov. 1, 2017	
80403	Traffic Barrier Terminal, Type 1 Special	Articles 631.04 and 631.12	Nov. 1, 2018	

The following special provisions have been deleted from use.

<u>File Name</u>	<u>Special Provision Title</u>	<u>Effective</u>	<u>Revised</u>
80317	Surface Testing of Hot-Mix Asphalt Overlays	Jan. 1, 2013	Aug. 1, 2019

The following special provisions require additional information from the designer. The additional information needs to be submitted as a separate document. The Project Coordination and Implementation section will then include the information in the applicable special provision.

- Bridge Demolition Debris
- Building Removal - Case I
- Building Removal – Case II
- Building Removal - Case III
- Building Removal-Case IV
- Completion Date
- Completion Date Plus Working Days
- DBE Participation
- Material Transfer Device
- Railroad Protective Liability Insurance
- Training Special Provisions
- Working Days

**COMPENSABLE DELAY COSTS (BDE)**

Effective: June 2, 2017

Revised: April 1, 2019

Revise Article 107.40(b) of the Standard Specifications to read:

“(b) Compensation. Compensation will not be allowed for delays, inconveniences, or damages sustained by the Contractor from conflicts with facilities not meeting the above definition; or if a conflict with a utility in an unanticipated location does not cause a shutdown of the work or a documentable reduction in the rate of progress exceeding the limits set herein. The provisions of Article 104.03 notwithstanding, compensation for delays caused by a utility in an unanticipated location will be paid according to the provisions of this Article governing minor and major delays or reduced rate of production which are defined as follows.

- (1) Minor Delay. A minor delay occurs when the work in conflict with the utility in an unanticipated location is completely stopped for more than two hours, but not to exceed two weeks.
- (2) Major Delay. A major delay occurs when the work in conflict with the utility in an unanticipated location is completely stopped for more than two weeks.
- (3) Reduced Rate of Production Delay. A reduced rate of production delay occurs when the rate of production on the work in conflict with the utility in an unanticipated location decreases by more than 25 percent and lasts longer than seven calendar days.”

Revise Article 107.40(c) of the Standard Specifications to read:

“(c) Payment. Payment for Minor, Major, and Reduced Rate of Production Delays will be made as follows.

- (1) Minor Delay. Labor idled which cannot be used on other work will be paid for according to Article 109.04(b)(1) and (2) for the time between start of the delay and the minimum remaining hours in the work shift required by the prevailing practice in the area.

Equipment idled which cannot be used on other work, and which is authorized to standby on the project site by the Engineer, will be paid for according to Article 109.04(b)(4).

- (2) Major Delay. Labor will be the same as for a minor delay.

Equipment will be the same as for a minor delay, except Contractor-owned equipment will be limited to two weeks plus the cost of move-out to either the

Contractor's yard or another job and the cost to re-mobilize, whichever is less. Rental equipment may be paid for longer than two weeks provided the Contractor presents adequate support to the Department (including lease agreement) to show retaining equipment on the job is the most economical course to follow and in the public interest.

- (3) Reduced Rate of Production Delay. The Contractor will be compensated for the reduced productivity for labor and equipment time in excess of the 25 percent threshold for that portion of the delay in excess of seven calendar days. Determination of compensation will be in accordance with Article 104.02, except labor and material additives will not be permitted.

Payment for escalated material costs, escalated labor costs, extended project overhead, and extended traffic control will be determined according to Article 109.13."

Revise Article 108.04(b) of the Standard Specifications to read:

"(b) No working day will be charged under the following conditions.

- (1) When adverse weather prevents work on the controlling item.
- (2) When job conditions due to recent weather prevent work on the controlling item.
- (3) When conduct or lack of conduct by the Department or its consultants, representatives, officers, agents, or employees; delay by the Department in making the site available; or delay in furnishing any items required to be furnished to the Contractor by the Department prevents work on the controlling item.
- (4) When delays caused by utility or railroad adjustments prevent work on the controlling item.
- (5) When strikes, lock-outs, extraordinary delays in transportation, or inability to procure critical materials prevent work on the controlling item, as long as these delays are not due to any fault of the Contractor.
- (6) When any condition over which the Contractor has no control prevents work on the controlling item."

Revise Article 109.09(f) of the Standard Specifications to read:

"(f) Basis of Payment. After resolution of a claim in favor of the Contractor, any adjustment in time required for the work will be made according to Section 108. Any adjustment in the costs to be paid will be made for direct labor, direct materials, direct equipment, direct jobsite overhead, direct offsite overhead, and other direct costs allowed by the resolution. Adjustments in costs will not be made for interest charges, loss of anticipated profit, undocumented loss of efficiency, home office overhead and unabsorbed overhead

other than as allowed by Article 109.13, lost opportunity, preparation of claim expenses and other consequential indirect costs regardless of method of calculation.

The above Basis of Payment is an essential element of the contract and the claim cost recovery of the Contractor shall be so limited.”

Add the following to Section 109 of the Standard Specifications.

**“109.13 Payment for Contract Delay.** Compensation for escalated material costs, escalated labor costs, extended project overhead, and extended traffic control will be allowed when such costs result from a delay meeting the criteria in the following table.

Contract Type	Cause of Delay	Length of Delay
Working Days	Article 108.04(b)(3) or Article 108.04(b)(4)	No working days have been charged for two consecutive weeks.
Completion Date	Article 108.08(b)(1) or Article 108.08(b)(7)	The Contractor has been granted a minimum two week extension of contract time, according to Article 108.08.

Payment for each of the various costs will be according to the following.

- (a) Escalated Material and/or Labor Costs. When the delay causes work, which would have otherwise been completed, to be done after material and/or labor costs have increased, such increases will be paid. Payment for escalated material costs will be limited to the increased costs substantiated by documentation furnished by the Contractor. Payment for escalated labor costs will be limited to those items in Article 109.04(b)(1) and (2), except the 35 percent and 10 percent additives will not be permitted.
- (b) Extended Project Overhead. For the duration of the delay, payment for extended project overhead will be paid as follows.
  - (1) Direct Jobsite and Offsite Overhead. Payment for documented direct jobsite overhead and documented direct offsite overhead, including onsite supervisory and administrative personnel, will be allowed according to the following table.

Original Contract Amount	Supervisory and Administrative Personnel
Up to \$5,000,000	One Project Superintendent
Over \$ 5,000,000 - up to \$25,000,000	One Project Manager, One Project Superintendent or Engineer, and One Clerk
Over \$25,000,000 - up to \$50,000,000	One Project Manager, One Project Superintendent, One Engineer, and

	One Clerk
Over \$50,000,000	One Project Manager, Two Project Superintendents, One Engineer, and One Clerk

- (2) Home Office and Unabsorbed Overhead. Payment for home office and unabsorbed overhead will be calculated as 8 percent of the total delay cost.
- (c) Extended Traffic Control. Traffic control required for an extended period of time due to the delay will be paid for according to Article 109.04.

When an extended traffic control adjustment is paid under this provision, an adjusted unit price as provided for in Article 701.20(a) for increase or decrease in the value of work by more than ten percent will not be paid.

Upon payment for a contract delay under this provision, the Contractor shall assign subrogation rights to the Department for the Department's efforts of recovery from any other party for monies paid by the Department as a result of any claim under this provision. The Contractor shall fully cooperate with the Department in its efforts to recover from another party any money paid to the Contractor for delay damages under this provision."

**CONSTRUCTION AIR QUALITY – DIESEL RETROFIT (BDE)**

Effective: June 1, 2010

Revised: November 1, 2014

The reduction of emissions of particulate matter (PM) for off-road equipment shall be accomplished by installing retrofit emission control devices. The term "equipment" refers to diesel fuel powered devices rated at 50 hp and above, to be used on the jobsite in excess of seven calendar days over the course of the construction period on the jobsite (including rental equipment).

Contractor and subcontractor diesel powered off-road equipment assigned to the contract shall be retrofitted using the phased in approach shown below. Equipment that is of a model year older than the year given for that equipment's respective horsepower range shall be retrofitted:

Effective Dates	Horsepower Range	Model Year
June 1, 2010 <sup>1/</sup>	600-749	2002
	750 and up	2006
June 1, 2011 <sup>2/</sup>	100-299	2003
	300-599	2001
	600-749	2002
	750 and up	2006
June 1, 2012 <sup>2/</sup>	50-99	2004
	100-299	2003
	300-599	2001
	600-749	2002
	750 and up	2006

1/ Effective dates apply to Contractor diesel powered off-road equipment assigned to the contract.

2/ Effective dates apply to Contractor and subcontractor diesel powered off-road equipment assigned to the contract.

The retrofit emission control devices shall achieve a minimum PM emission reduction of 50 percent and shall be:

- a) Included on the U.S. Environmental Protection Agency (USEPA) *Verified Retrofit Technology List* (<http://www.epa.gov/cleandiesel/verification/verif-list.htm>), or verified by the California Air Resources Board (CARB) (<http://www.arb.ca.gov/diesel/verdev/vt/cvt.htm>); or
- b) Retrofitted with a non-verified diesel retrofit emission control device if verified retrofit emission control devices are not available for equipment proposed to be used on the project, and if the Contractor has obtained a performance certification from the retrofit

device manufacturer that the emission control device provides a minimum PM emission reduction of 50 percent.

Note: Large cranes (Crawler mounted cranes) which are responsible for critical lift operations are exempt from installing retrofit emission control devices if such devices adversely affect equipment operation.

Diesel powered off-road equipment with engine ratings of 50 hp and above, which are unable to be retrofitted with verified emission control devices or if performance certifications are not available which will achieve a minimum 50 percent PM reduction, may be granted a waiver by the Department if documentation is provided showing good faith efforts were made by the Contractor to retrofit the equipment.

Construction shall not proceed until the Contractor submits a certified list of the diesel powered off-road equipment that will be used, and as necessary, retrofitted with emission control devices. The list(s) shall include (1) the equipment number, type, make, Contractor/rental company name; and (2) the emission control devices make, model, USEPA or CARB verification number, or performance certification from the retrofit device manufacturer. Equipment reported as fitted with emissions control devices shall be made available to the Engineer for visual inspection of the device installation, prior to being used on the jobsite.

The Contractor shall submit an updated list of retrofitted off-road construction equipment as retrofitted equipment changes or comes on to the jobsite. The addition or deletion of any diesel powered equipment shall be included on the updated list.

If any diesel powered off-road equipment is found to be in non-compliance with any portion of this special provision, the Engineer will issue the Contractor a diesel retrofit deficiency deduction.

Any costs associated with retrofitting any diesel powered off-road equipment with emission control devices shall be considered as included in the contract unit prices bid for the various items of work involved and no additional compensation will be allowed. The Contractor's compliance with this notice and any associated regulations shall not be grounds for a claim.

### **Diesel Retrofit Deficiency Deduction**

When the Engineer determines that a diesel retrofit deficiency exists, a daily monetary deduction will be imposed for each calendar day or fraction thereof the deficiency continues to exist. The calendar day(s) will begin when the time period for correction is exceeded and end with the Engineer's written acceptance of the correction. The daily monetary deduction will be \$1,000.00 for each deficiency identified.

The deficiency will be based on lack of diesel retrofit emissions control.

If a Contractor accumulates three diesel retrofit deficiency deductions for the same piece of equipment in a contract period, the Contractor will be shutdown until the deficiency is corrected.

Such a shutdown will not be grounds for any extension of the contract time, waiver of penalties, or be grounds for any claim.

80261

**DISPOSAL FEES (BDE)**

Effective: November 1, 2018

Replace Articles 109.04(b)(5) – 109.04(b)(8) of the Standard Specifications with the following:

- “(5) Disposal Fees. When the extra work performed includes paying for disposal fees at a clean construction and demolition debris facility, an uncontaminated soil fill operation or a landfill, the Contractor shall receive, as administrative costs, an amount equal to five percent of the first \$10,000 and one percent of any amount over \$10,000 of the total approved costs of such fees.
- (6) Miscellaneous. No additional allowance will be made for general superintendence, the use of small tools, or other costs for which no specific allowance is herein provided.
- (7) Statements. No payment will be made for work performed on a force account basis until the Contractor has furnished the Engineer with itemized statements of the cost of such force account work. Statements shall be accompanied and supported by invoices for all materials used and transportation charges. However, if materials used on the force account work are not specifically purchased for such work but are taken from the Contractor's stock, then in lieu of the invoices, the Contractor shall furnish an affidavit certifying that such materials were taken from his/her stock, that the quantity claimed was actually used, and that the price and transportation claimed represent the actual cost to the Contractor.

Itemized statements at the cost of force account work shall be detailed as follows.

- a. Name, classification, date, daily hours, total hours, rate, and extension for each laborer and foreman. Payrolls shall be submitted to substantiate actual wages paid if so requested by the Engineer.
  - b. Designation, dates, daily hours, total hours, rental rate, and extension for each unit of machinery and equipment.
  - c. Quantities of materials, prices and extensions.
  - d. Transportation of materials.
  - e. Cost of property damage, liability and workmen's compensation insurance premiums, unemployment insurance contributions, and social security tax.
- (8) Work Performed by an Approved Subcontractor. When extra work is performed by an approved subcontractor, the Contractor shall receive, as administrative costs, an amount equal to five percent of the total approved costs of such work with the minimum payment being \$100.

- (9) All statements of the cost of force account work shall be furnished to the Engineer not later than 60 days after receipt of the Central Bureau of Construction form "Extra Work Daily Report". If the statement is not received within the specified time frame, all demands for payment for the extra work are waived and the Department is released from any and all such demands. It is the responsibility of the Contractor to ensure that all statements are received within the specified time regardless of the manner or method of delivery."

80402

**DOWEL BAR INSERTER (BDE)**

Effective: January 1, 2017

Revised: January 1, 2018

Add the following to Article 420.03 of the Standard Specifications.

“(l) Mechanical Dowel Bar Inserter .....1103.20”

Revise the first paragraph of Article 420.05(b)(1) of the Supplemental Specifications to read:

“Preformed or Drilled Holes. If applicable, the tie bars shall be installed after the dowel bars have been tested with the MIT Scan-2 device according to Article 420.05(c)(2)b.2. The tie bars shall be installed with a nonshrink grout or chemical adhesive providing a minimum pull-out strength as follows.”

Revise Article 420.05(c) of the Standard Specifications to read:

“(c) Transverse Contraction Joints. Transverse contraction joints shall consist of planes of weakness created by sawing grooves in the surface of the pavement and shall include load transfer devices consisting of dowel bars. Transverse contraction joints shall be according to the following.”

Revise Article 420.05(c)(2) of the Standard Specifications to read:

“(2) Dowel Bars. Dowel Bars shall be installed parallel to the centerline of the pavement and parallel to the proposed pavement surface. Installation shall be according to one of the following methods.

- a. Dowel Bar Assemblies. The assembly shall act as a rigid unit with each component securely held in position relative to the other members of the assembly. The entire assembly shall be held securely in place by means of nails which shall penetrate the stabilized subbase. At least ten nails shall be used for each 10, 11, or 12 ft (3, 3.3, or 3.6 m) section of assembly.

Metal stakes shall be used instead of nails, with soil or granular subbase. The stakes shall loop over or attach to the top parallel spacer bar of the assembly and penetrate the subgrade or subbase at least 12 in. (300 mm).

At the location of each dowel bar assembly, the subgrade or subbase shall be reshaped and re-tamped when necessary.

Prior to placing concrete, any deviation of the dowel bars from the correct horizontal or vertical alignment (horizontal skew or vertical tilt) greater than 3/8 in. in 12 in (9 mm in 300 mm) shall be corrected and a light coating of oil shall be uniformly applied to all dowel bars.

Care shall be exercised in depositing the concrete at the dowel bar assemblies so the horizontal and vertical alignment will be retained.

- b. Dowel Bar Insertion. The dowel bars may be placed in the pavement slab with a mechanical dowel bar inserter (DBI) attached to a formless paver for pavements  $\geq 7.0$  in. (175 mm) in thickness. A light coating of oil shall be uniformly applied to all dowel bars.

The DBI shall insert the dowel bars with vibration into the plastic concrete after the concrete has been struck off and consolidated without deformation of the slab. After the bars have been inserted, the concrete shall be refinished and no voids shall exist around the dowel bars. The forward movement of the paver shall not be interrupted by the inserting of the dowel bars.

The location of each row of dowel bars shall be marked in a manner to facilitate where to insert the bars, and where to saw the transverse joint.

1. Placement Tolerances for Dowel Bars. The DBI shall place the dowel bars in the concrete pavement within the following tolerances.

- (a.) Longitudinal Translation (Mislocation). Longitudinal translation (mislocation) shall be defined as the position of the center of the dowel bar along the longitudinal axis, in relation to the sawed joint.

The quality control tolerance for longitudinal translation shall not exceed 2.0 in (50 mm). If this tolerance is exceeded, adjustments shall be made to the paving operation.

Any joint having two or more dowel bars with an embedment length less than 4.0 in. (100 mm) within 12 in. (300 mm) of the same wheelpath will be considered unacceptable. The left and right wheelpaths shall be determined by excluding the middle 2.5 ft (0.8 m) of the pavement lane, and by excluding the outer 1.0 ft (0.3 m) measured from each pavement lane edge. Any joint having an average dowel bar embedment length less than 5.25 in. (130 mm) will also be considered unacceptable. Embedment length shall be defined as the length of dowel bar embedded on the short side of the sawed joint. An unacceptable joint shall be replaced with a minimum of 6 ft (1.8 m) of pavement centered over the joint according to Section 442 for Class B patches.

- (b.) Horizontal Translation (Mislocation). Horizontal translation (mislocation) shall be defined as the difference in the actual dowel bar location parallel to the longitudinal or edge joint from its theoretical position as shown on the plans.

The quality control tolerance for horizontal translation shall not exceed 2.0 in. (50 mm). If this tolerance is exceeded, adjustments shall be made to the paving operation.

Any joint having a dowel bar with a translation greater than 4.0 in. (100 mm) will be considered unacceptable, but may remain in place unless the Engineer determines the joint will not function. If the joint is unable to remain in place, the joint shall be replaced with a minimum of 6 ft (1.8 m) of pavement centered over the joint according to Section 442 for Class B patches.

- (c.) Vertical Translation (Mislocation). Vertical translation (mislocation) shall be defined as the difference in the vertical position of the dowel bar relative to the theoretical midpoint of the slab.

The quality control tolerance for vertical translation shall be as shown in the following table. If these tolerances are exceeded, adjustments shall be made to the paving operation.

Pavement Thickness	Dowel Bar Diameter	Vertical Translation Tolerance Above Midpoint	Vertical Translation Tolerance Below Midpoint
≥7 in. to <8 in. (≥175 mm to <200 mm)	1.25 in. (31 mm)	0.25 in. (6 mm)	0.5 in. (13 mm)
≥8 in. to <9 in. (≥200 mm to <225 mm)	1.50 in. (38 mm)	0.25 in. (6 mm)	0.5 in. (13 mm)
≥9 in. to <10 in. (≥225 mm to <250 mm)	1.50 in. (38 mm)	0.75 in. (19 mm)	0.75 in. (19 mm)
≥10 in. (≥250 mm)	1.50 in. (38 mm)	0.75 in. (19 mm)	1.0 in. (25 mm)

Any joint having a dowel bar with top concrete cover less than  $T/3$ , where  $T$  is slab thickness, will be considered unacceptable. Any joint having 2 or more dowel bars with bottom concrete cover less than 2.0 in. (50 mm) will also be considered unacceptable. An unacceptable joint shall be replaced with a minimum of 6 ft (1.8 m) of pavement according to Section 442 for Class B patches.

- (d.) Vertical Tilt or Horizontal Skew (Misalignment). Vertical tilt or horizontal skew (misalignment) shall be defined as the difference in position of the dowel bar ends with respect to each other. Vertical tilt is measured in the vertical axis whereas horizontal skew is measured in the horizontal axis. Misalignment shall be measured in terms of a joint score. The joint score shall be defined as the degree of misalignment evaluated for a single

transverse joint for each lane of pavement. The joint score shall be determined as follows:

$$Joint\ Score = \left( 1 + \left( \frac{x}{x-n} \right) \sum_{i=1}^{x-n} W_i \right)$$

where:

- $W_i$  = weighting factor (Table 1) for dowel  $i$
- $x$  = number of dowels in a single joint
- $n$  = number of dowels excluded from the joint score calculation due to measurement interference

*Single Dowel Misalignment* – The degree of misalignment applicable to a single dowel bar, calculated as:

$$Single\ Dowel\ Misalignment = \sqrt{(Horizontal\ Skew)^2 + (Vertical\ Tilt)^2}$$

Table 1. Weighting Factors in Joint Score Determination	
Single Dowel Bar Misalignment (SDM)	W, Weighting Factor
SDM ≤ 0.6 in. (15 mm)	0
0.6 in. (15 mm) < SDM ≤ 0.8 in. (20 mm)	2
0.8 in. (20 mm) < SDM ≤ 1 in. (25 mm)	4
1 in. (25 mm) < SDM ≤ 1.5 in. (38 mm)	5
1.5 in. (38 mm) < SDM	10

The quality control tolerance for vertical tilt or horizontal skew shall not exceed 0.6 in. (15 mm). If the tolerance is exceeded for either one, adjustments shall be made to the paving operation.

Any joint having a dowel bar with a vertical tilt or horizontal skew greater than 1.5 in. (38 mm) shall be cut. If more than one dowel bar is required to be cut in the joint, the joint will be considered unacceptable and shall be replaced with a minimum of 6 ft (1.8 m) of pavement centered over the joint according to Section 442 for Class B patches.

Single dowel bar misalignment shall be controlled to provide the joint scores shown in the following table.

Number of Dowel Bars in the Joint	Maximum Joint Score
< 5	4
≥ 5 but ≤ 9	8
> 9	12

A joint score greater than the specified maximum will be considered locked. Three consecutive joints with a score greater than the specified maximum total score will all be considered unacceptable.

Three consecutive locked joints shall be corrected by selecting one joint and cutting a dowel bar. Preference shall be given to cutting a dowel bar within the middle 2.5 ft (0.8 m) of the pavement lane to avoid the wheelpaths. If none of the three locked joints will have a joint score less than or equal to the specified maximum after selecting one dowel bar to cut, one of the joints shall be replaced with a minimum of 6 ft (1.8 m) of pavement centered over the joint according to Section 442 for Class B patches.

(e.) For unacceptable work, the Contractor may propose alternative repairs for consideration by the Engineer.

2. Testing of Dowel Bar Placement. The placement of the dowel bars shall be tested within 24 hours of paving with a calibrated MIT Scan-2 device according to "Use of Magnetic Tomography Technology to Evaluate Dowel Placement" (Publication No. FHWA-IF-06-006) by the Federal Highway Administration.

A trained operator shall perform the testing, and all testing shall be performed in the presence of the Engineer. The device shall be calibrated to the type and size dowel bar used in the work according to the manufacturer's instructions. Calibration documentation shall be provided to the Engineer prior to construction. The device shall be recalibrated and/or validate readings as required by the Engineer. The device may be utilized as a process control and make necessary adjustments to ensure the dowel bars are placed in the correct location.

(a.) Test Section. Prior to start of production paving, a test section consisting of 30 transverse joints shall be constructed. The test section may be performed on the actual pavement, but production paving shall not begin until an acceptable test section has been constructed. The test section will be considered acceptable when all of the following are met:

- (1.) 90 percent of the dowel bars meet the quality control tolerance for longitudinal, horizontal, or vertical translation (mislocation);
- (2.) 90 percent of the dowel bars meet the quality control tolerance for vertical tilt or horizontal skew deviation (misalignment); and
- (3.) none of the joints are considered unacceptable prior to a corrective measure for mislocation or misalignment.

If the test section fails, another test section consisting of 30 joints shall be constructed.

The test section requirement may be waived by the Engineer if the Contractor has constructed an acceptable test section and successfully used the DBI on a Department contract within the same calendar year.

- (b.) Production Paving. After the test section is approved, production paving may begin. The mislocation and misalignment of each dowel bar for the first ten joints constructed, and every tenth joint thereafter, shall be tested.

If two consecutive days of paving result in 5 percent or more of the joints on each day being unacceptable prior to a corrective measure, production paving shall be discontinued and a new test section shall be constructed.

If any joint is found to be unacceptable prior to a corrective measure, testing of additional joints on each side of the unacceptable joint shall be performed until acceptable joints are found.

- (c.) Test Report. Test reports shall be provided to the Engineer within two working days of completing each day's testing. The test report shall include the following.

- (1.) Contract number, placement date, county-route-section, direction of traffic, scan date, Contractor, and name of individual performing the tests.
- (2.) Provide the standard report generated from the on-board printer of the imaging technology used for every dowel and joint measured.
- (3.) For every dowel measured, provide the joint identification number, lane number and station, dowel bar number or x-location, direction of testing and reference joint location/edge location, longitudinal translation, horizontal translation, vertical translation, vertical tilt, and horizontal skew.
- (4.) Identify each dowel bar with a maximum longitudinal, horizontal, or vertical translation that has been exceeded. Identify each dowel bar with a maximum vertical tilt or horizontal skew deviation that has been exceeded.
- (5.) Joint Score Details: Provide the joint identification number, lane number, station, and calculated joint score for each joint.

- (6.) Locked Joint Identification: Identify each joint where the maximum joint score is exceeded.
- (d.) Exclusions. Exclude the following from dowel bar mislocation and misalignment measurements.
- (1.) Transverse construction joints (headers).
  - (2.) Dowel bars within 24 in. (610 mm) of metallic manholes, inlets, metallic castings, or other nearby or underlying steel reinforced objects.
  - (3.) The outside dowel bar when tie bars are installed with mechanical equipment in fresh concrete. For tie bar installations involving preformed or drilled holes, installation of the tie bar shall be performed after testing with the MIT Scan-2 device.
  - (4.) Joints located directly under high voltage power lines.
  - (5.) Subject to the approval of the Engineer, any other contributors to magnetic interference.
- (e.) Deficiency Deduction. When the Contractor has cut 25 dowel bars to correct unacceptable joints, the Contractor shall be liable and shall pay to the Department a deficiency deduction of \$500.00 for the cost of the bars. Thereafter, an additional deficiency deduction of \$20.00 for each additional bar cut will be assessed."

Add the following to Section 1103 of the Standard Specifications.

**"1103.20 Mechanical Dowel Bar Inserter.** The mechanical dowel bar inserter (DBI) shall be self-contained and supported on the formless paver with the ability to move separately from the paver. The DBI shall be equipped with insertion forks along with any other devices necessary for finishing the concrete the full width of the pavement. The insertion forks shall have the ability to vibrate at a minimum frequency of 3000 VPM."

**GEOTECHNICAL FABRIC FOR PIPE UNDERDRAINS AND FRENCH DRAINS (BDE)**

Effective: November 1, 2019

Revise Article 1080.01(a) of the Standard Specifications to read:

“(a) Fabric Materials. Fabric materials shall be as follows.

- (1) Knitted Fabric. Knitted fabric envelope shall be Type A according to ASTM D 6707 and be a continuous one piece knitted polymeric material that fits over the pipe underdrain like a sleeve. It shall be free from any chemical treatment or coating that might significantly reduce porosity and permittivity.
- (2) Woven or Nonwoven Fabric. The fabric shall be Class 3 according to AASHTO M 288 and consist of woven yarns or nonwoven filaments of polyolefins or polyesters. Woven slit film geotextiles (i.e. geotextiles made from yarns of a flat, tape like character) shall not be permitted. The yarns or filaments shall be dimensionally stable (i.e. maintain their relative position with respect to each other) and resistant to delamination. The yarns or filaments shall be free from any chemical treatment or coating that might significantly reduce porosity and permittivity.
- (3) Physical Properties. The physical properties for knitted, woven, and nonwoven fabrics shall be according to the following.

PHYSICAL PROPERTIES			
	Knitted <sup>1/</sup>	Woven <sup>2/</sup>	Nonwoven <sup>2/</sup>
Grab Strength, lb (N) ASTM D 4632 <sup>3/</sup>	--	180 (800) min.	112 (500) min.
Elongation/Grab Strain, % ASTM D 4632 <sup>3/</sup>	--	49 max.	50 min.
Trapezoidal Tear Strength, lb (N) ASTM D 4533 <sup>3/</sup>	--	67 (300) min.	40 (180) min.
Puncture Strength, lb (N) ASTM D 6241 <sup>3/</sup>	180 (800) min.	370 (1650) min.	222 (990) min.
Apparent Opening Size, Sieve No. (mm) ASTM D 4751 <sup>4/</sup>	30 (0.60) max.	40 (0.425) max.	40 (0.425) max.
Permittivity, sec <sup>-1</sup> ASTM D 4491	1.0 min.		
Ultraviolet Stability, % retained strength after 500 hours of exposure ASTM D 4355	--	50 min.	50 min.

1/ Manufacturer's certification to meet test requirements.

2/ NTPEP results or manufacturer's certification to meet test requirements.

3/ Values represent the minimum average roll value (MARV) in the weaker principle direction [machine direction (MD) or cross-machine direction (XD)].

4/ Values represent the maximum average roll value.”

Revise Article 1080.05 of the Standard Specifications to read:

**“1080.05 Geotechnical Fabric for French Drains and Pipe Underdrains, Type 2.** Geotechnical fabric for french drains and pipe underdrains, Type 2 shall be Class 3 according to AASHTO M 288 and consist of woven yarns or nonwoven filaments of polyolefins or polyesters. Woven slit film geotextiles (i.e. geotextiles made from yarns of a flat, tape-like character) shall not be permitted. The yarns or filaments shall be dimensionally stable (i.e. maintain their relative position with respect to each other) and resistant to delamination. The yarns or filaments shall be free from any chemical treatment or coating that might significantly reduce porosity and permittivity.

The fabric shall be according to the following.

PHYSICAL PROPERTIES <sup>1/</sup>		
	Woven	Nonwoven
Grab Strength, lb (N) ASTM D 4632 <sup>2/</sup>	180 (800) min.	112 (500) min.
Elongation/Grab Strain, % ASTM D 4632 <sup>2/</sup>	49 max.	50 min.
Trapezoidal Tear Strength, lb (N) ASTM D 4533 <sup>2/</sup>	67 (300) min.	40 (180) min.
Puncture Strength, lb (N) ASTM D 6241 <sup>2/</sup>	370 (1650) min.	222 (990) min.
Apparent Opening Size, Sieve No. (mm) ASTM D 4751 <sup>3/</sup>	60 (0.25) max.	
Permittivity, sec <sup>-1</sup> ASTM D 4491	0.2 min.	
Ultraviolet Stability % retained strength after 500 hours of exposure - ASTM D 4355	50 min.	

1/ NTPEP results to meet test requirements. Manufacturer shall have public release status and current reports on laboratory results in Test Data of NTPEP's DataMine.

2/ Values represent the minimum average roll value (MARV) in the weaker principle direction [machine direction (MD) or cross-machine direction (XD)].

3/ Values represent the maximum average roll value.”

**MANHOLES, VALVE VAULTS, AND FLAT SLAB TOPS (BDE)**

Effective: January 1, 2018  
 Revised: March 1, 2019

Description. In addition to those manufactured according to the current standards included in this contract, manholes, valve vaults, and flat slab tops manufactured prior to March 1, 2019, according to the previous Highway Standards listed below will be accepted on this contract:

Product	Previous Standards		
Precast Manhole Type A, 4' (1.22 m) Diameter	602401-05	602401-04	602401-03
Precast Manhole Type A, 5' (1.52 m) Diameter	602402-01	602402	602401-03
Precast Manhole Type A, 6' (1.83 m) Diameter	602406-09	602406-08	602406-07
Precast Manhole Type A, 7' (2.13 m) Diameter	602411-07	602411-06	602411-05
Precast Manhole Type A, 8' (2.44 m) Diameter	602416-07	602416-06	602416-05
Precast Manhole Type A, 9' (2.74 m) Diameter	602421-07	602421-06	602421-05
Precast Manhole Type A, 10' (3.05 m) Diameter	602426-01	602426	
Precast Valve Vault Type A, 4' (1.22 m) Diameter	602501-04	602501-03	602501-02
Precast Valve Vault Type A, 5' (1.52 m) Diameter	602506-01	602506	602501-02
Precast Reinforced Concrete Flat Slab Top	602601-05	602601-04	

The following revisions to the Standard Specifications shall apply to manholes, valve vaults, and flat slab tops manufactured according to the current standards included in this contract:

Revise Article 602.02(g) of the Standard Specifications to read:

“(g) Structural Steel (Note 4)..... 1006.04

Note 4. All components of the manhole joint splice shall be galvanized according to the requirements of AASHTO M 111 or M 232 as applicable.”

Add the following to Article 602.02 of the Standard Specifications:

“(s) Anchor Bolts and Rods (Note 5)..... 1006.09

Note 5. The threaded rods for the manhole joint splice shall be according to the requirements of ASTM F 1554, Grade 55, (Grade 380).”

Revise the second paragraph of Article 1042.10 of the Standard Specifications to read:

“Catch basin Types A, B, C, and D; Manhole Type A; Inlet Types A and B; Drainage Structures Types 1, 2, 3, 4, 5, and 6; Valve Vault Type A; and reinforced concrete flat slab top (Highway Standard 602601) shall be manufactured according to AASHTO M 199 (M 199M), except as shown on the plans. Additionally, catch basins, inlets, and drainage structures shall have a minimum concrete compressive strength of 4500 psi (31,000 kPa) at 28 days and manholes,

valve vaults, and reinforced concrete flat slab tops shall have a minimum concrete compressive strength of 5000 psi (34,500 kPa) at 28 days.”

80393

**SILT FENCE, INLET FILTERS, GROUND STABILIZATION AND RIPRAP FILTER FABRIC (BDE)**

Effective: November 1, 2019

Revised: July 1, 2021

Revise Article 280.02(m) and add Article 280.02(n) so the Standard Specifications read:

- “(m) Above Grade Inlet Filter (Fitted)..... 1081.15(j)
- “(n) Above Grade Inlet Filter (Non-Fitted)..... 1081.15(k)”

Revise the last sentence of the first paragraph in Article 280.04(c) of the Standard Specifications to read:

“The protection shall be constructed with hay or straw bales, silt filter fence, above grade inlet filters (fitted and non-fitted), or inlet filters.

Revise the first sentence of the second paragraph in Article 280.04(c) of the Standard Specifications to read:

“When above grade inlet filters (fitted and non-fitted) are specified, they shall be of sufficient size to completely span and enclose the inlet structure.”

Revise Article 1080.02 of the Standard Specifications to read:

**“1080.02 Geotextile Fabric.** The fabric for silt filter fence shall consist of woven fabric meeting the requirements of AASHTO M 288 for unsupported silt fence.

The fabric for ground stabilization shall consist of woven yarns or nonwoven filaments of polyolefins or polyesters. Woven fabrics shall be Class 2 and nonwoven fabrics shall be Class 1 according to AASHTO M 288.

The physical properties for silt fence and ground stabilization fabrics shall be according to the following.

PHYSICAL PROPERTIES			
	Silt Fence Woven <sup>1/</sup>	Ground Stabilization Woven <sup>2/</sup>	Ground Stabilization Nonwoven <sup>2/</sup>
Grab Strength, lb (N) <sup>3/</sup> ASTM D 4632	123 (550) MD 101 (450) XD	247 (1100) min. <sup>4/</sup>	202 (900) min. <sup>4/</sup>
Elongation/Grab Strain, % ASTM D 4632 <sup>4/</sup>	49 max.	49 max.	50 min.
Trapezoidal Tear Strength, lb (N) ASTM D 4533 <sup>4/</sup>	--	90 (400) min.	79 (350) min.
Puncture Strength, lb (N) ASTM D 6241 <sup>4/</sup>	--	494 (2200) min.	433 (1925) min.
Apparent Opening Size, Sieve No. (mm) ASTM D 4751 <sup>5/</sup>	30 (0.60) max.	40 (0.43) max.	40 (0.43) max.
Permittivity, sec <sup>-1</sup> ASTM D 4491	0.05 min.		
Ultraviolet Stability, % retained strength after 500 hours of exposure ASTM D 4355	70 min.	50 min.	50 min.

1/ NTPEP results or manufacturer's certification to meet test requirements.

2/ NTPEP results to meet test requirements. Manufacturer shall have public release status and current reports on laboratory results in Test Data of NTPEP's DataMine.

3/ MD = Machine direction. XD = Cross-machine direction.

4/ Values represent the minimum average roll value (MARV) in the weaker principle direction, MD or XD.

5/ Values represent the maximum average roll value."

Revise Article 1080.03 of the Standard Specifications to read:

**"1080.03 Filter Fabric.** The filter fabric shall consist of woven yarns or nonwoven filaments of polyolefins or polyesters. Woven fabrics shall be Class 3 for riprap gradations RR 4 and RR 5, and Class 2 for RR 6 and RR 7 according to AASHTO M 288. Woven slit film geotextiles (i.e. geotextiles made from yarns of a flat, tape-like character) shall not be permitted. Nonwoven fabrics shall be Class 2 for riprap gradations RR 4 and RR 5, and Class 1 for RR 6 and RR 7 according to AASHTO M 288. After forming, the fabric shall be processed so that the yarns or filaments retain their relative positions with respect to each other. The fabric shall be new and undamaged.

The filter fabric shall be manufactured in widths of not less than 6 ft (2 m). Sheets of fabric may be sewn together with thread of a material meeting the chemical requirements given for the yarns or filaments to form fabric widths as required. The sheets of filter fabric shall be sewn together at the point of manufacture or another approved location.

The filter fabric shall be according to the following.

PHYSICAL PROPERTIES <sup>1/</sup>				
	Gradation Nos. RR 4 & RR 5		Gradation Nos. RR 6 & RR 7	
	Woven	Nonwoven	Woven	Nonwoven
Grab Strength, lb (N) ASTM D 4632 <sup>2/</sup>	180 (800) min.	157 (700) min.	247 (1100) min.	202 (900) min.
Elongation/Grab Strain, % ASTM D 4632 <sup>2/</sup>	49 max.	50 min.	49 max.	50 min.
Trapezoidal Tear Strength, lb (N) ASTM D 4533 <sup>2/</sup>	67 (300) min.	56 (250) min.	90 (400) min.	79 (350) min.
Puncture Strength, lb (N) ASTM D 6241 <sup>2/</sup>	370 (1650) min.	309 (1375) min.	494 (2200) min.	433 (1925) min.
Ultraviolet Stability, % retained strength after 500 hours of exposure - ASTM D 4355	50 min.			

1/ NTPEP results to meet test requirements. Manufacturer shall have public release status and current reports on laboratory results in Test Data of NTPEP's DataMine.

2/ Values represent the minimum average roll value (MARV) in the weaker principle direction [machine direction (MD) or cross-machine direction (XD)].

As determined by the Engineer, the filter fabric shall meet the requirements noted in the following after an onsite investigation of the soil to be protected.

Soil by Weight (Mass) Passing the No. 200 sieve (75 µm), %	Apparent Opening Size, Sieve No. (mm) - ASTM D 4751 <sup>1/</sup>	Permittivity, sec <sup>-1</sup> ASTM D 4491
49 max.	60 (0.25) max.	0.2 min.
50 min.	70 (0.22) max.	0.1 min.

1/ Values represent the maximum average roll value."

Revise Article 1081.15(i)(1) of the Standard Specifications to read:

"(i) Urethane Foam/Geotextile. Urethane foam/geotextile shall be triangular shaped having a minimum height of 10 in. (250 mm) in the center with equal sides and a minimum 20 in. (500 mm) base. The triangular shaped inner material shall be a low density urethane foam. The outer geotextile fabric cover shall consist of woven yarns or nonwoven

filaments made of polyolefins or polyesters placed around the inner material and shall extend beyond both sides of the triangle a minimum of 18 in. (450 mm). Woven filter fabric shall be Class 3 and nonwoven filter fabric shall be Class 2 according to AASHTO M 288.

(1) The geotextile shall meet the following properties.

PHYSICAL PROPERTIES		
	Woven	Nonwoven
Grab Strength, lb (N) ASTM D 4632 <sup>1/</sup>	180 (800) min.	157 (700) min.
Elongation/Grab Strain, % ASTM D 4632 <sup>1/</sup>	49 max.	50 min.
Trapezoidal Tear Strength, lb (N) ASTM D 4533 <sup>1/</sup>	67 (300) min.	56 (250) min.
Puncture Strength, lb (N) ASTM D 6241 <sup>1/</sup>	370 (1650) min.	309 (1375) min.
Apparent Opening Size, Sieve No. (mm) ASTM D 4751 <sup>2/</sup>	30 (0.60) max.	
Permittivity, sec <sup>-1</sup> ASTM D 4491	0.25 min.	
Ultraviolet Stability, % retained strength after 500 hours of exposure – ASTM D 4355	70 min.	

1/ Values represent the minimum average roll value (MARV) in the weaker principle direction [machine direction (MD) or cross-machine direction (XD)].

2/ Values represent the maximum average roll value.”

Add the following to Article 1081.15(i) of the Standard Specifications.

“(3) Certification. The manufacturer shall furnish a certificate with each shipment of urethane foam/geotextile assemblies stating the amount of product furnished and that the material complies with these requirements.”

Revise the title and first sentence of Article 1081.15(j) of the Standards Specifications to read:

“(j) Above Grade Inlet Filters (Fitted). Above grade inlet filters (fitted) shall consist of a rigid polyethylene frame covered with a fitted geotextile filter fabric.”

Revise Article 1081.15(j)(2) of the Standard Specifications to read:

(2) Fitted Geotextile Filter Fabric. The fitted geotextile filter fabric shall consist of woven yarns or nonwoven filaments made of polyolefins or polyesters. Woven filter fabric shall be Class 3 and nonwoven filter fabric shall be Class 2 according to AASHTO M 288. The filter shall be fabricated to provide a direct fit to the frame. The top of the filter shall integrate a coarse screen with a minimum apparent opening size

of 1/2 in. (13 mm) to allow large volumes of water to pass through in the event of heavy flows. The filter shall have integrated anti-buoyancy pockets capable of holding a minimum of 3.0 cu ft (0.08 cu m) of stabilization material. Each filter shall have a label with the following information sewn to or otherwise permanently adhered to the outside: manufacturer's name, product name, and lot, model, or serial number. The fitted geotextile filter fabric shall be according to the table in Article 1081.15(h)(3)a above."

Add Article 1081.15(k) to the Standard Specifications to read:

"(k) Above Grade Inlet Filters (Non-Fitted). Above grade inlet filters (non-fitted) shall consist of a geotextile fabric surrounding a metal frame. The frame shall consist of either a) a circular cage formed of welded wire mesh, or b) a collapsible aluminum frame, as described below.

(1) Frame Construction.

a) Welded Wire Mesh Frame. The frame shall consist of 6 in. x 6 in. (150 mm x 150 mm) welded wire mesh formed of #10 gauge (3.42 mm) steel conforming to ASTM A 185. The mesh shall be 30 in. (750 mm) tall and formed into a 42 in. (1.05 m) minimum diameter cylinder.

b) Collapsible Aluminum Frame. The collapsible aluminum frame shall consist of grade 6036 aluminum. The frame shall have anchor lugs that attach it to the inlet grate, which shall resist movement from water and debris. The collapsible joints of the frame shall have a locking device to secure the vertical members in place, which shall prevent the frame from collapsing while under load from water and debris.

(2) Geotextile Fabric. The geotextile fabric shall consist of woven yarns or nonwoven filaments made of polyolefins or polyesters. The woven filter fabric shall be a Class 3 and the nonwoven filter fabric shall be a Class 2 according to AASHTO M 288. The geotextile fabric shall be according to the table in Article 1081.15(h)(3)a above.

(3) Geotechnical Fabric Attachment to the Frame.

a) Welded Wire Mesh Frame. The woven or nonwoven geotextile fabric shall be wrapped 3 in. (75 mm) over the top member of a 6 in. x 6 in. (150 mm x 150 mm) welded wire mesh frame and secured with fastening rings constructed of wire conforming to ASTM A 641, A 809, A 370, and A 938 at 6 in. (150 mm) on center. The fastening rings shall penetrate both layers of geotextile and securely close around the steel mesh. The geotextile shall be secured to the sides of the welded wire mesh with fastening rings at a spacing of 1 per sq ft (11 per sq m) and securely close around a steel member.

- b) Collapsible Aluminum Frame. The woven or nonwoven fabric shall be secured to the aluminum frame along the top and bottom of the frame perimeter with strips of aluminum secured to the perimeter member, such that the anchoring system provides a uniformly distributed stress throughout the geotechnical fabric.
- (4) Certification. The manufacturer shall furnish a certificate with each shipment of above grade inlet filter assemblies stating the amount of product furnished and that the material complies with these requirements.”

80419

**TRAFFIC CONTROL DEVICES - CONES (BDE)**

Effective: January 1, 2019

Revise Article 701.15(a) of the Standard Specifications to read:

"(a) Cones. Cones are used to channelize traffic. Cones used to channelize traffic at night shall be reflectorized; however, cones shall not be used in nighttime lane closure tapers or nighttime lane shifts."

Revise Article 1106.02(b) of the Standard Specifications to read:

"(b) Cones. Cones shall be predominantly orange. Cones used at night that are 28 to 36 in. (700 to 900 mm) in height shall have two white circumferential stripes. If non-reflective spaces are left between the stripes, the spaces shall be no more than 2 in. (50mm) in width. Cones used at night that are taller than 36 in. (900 mm) shall have a minimum of two white and two fluorescent orange alternating, circumferential stripes with the top stripe being fluorescent orange. If non-reflective spaces are left between the stripes, the spaces shall be no more than 3 in. (75 mm) in width.

The minimum weights for the various cone heights shall be 4 lb for 18 in. (2 kg for 450 mm), 7 lb for 28 in. (3 kg for 700 mm), and 10 lb for 36 in. (5 kg for 900 mm) with a minimum of 60 percent of the total weight in the base. Cones taller than 36 in. shall be weighted per the manufacturer's specifications such that they are not moved by wind or passing traffic."

80409

**WORK ZONE TRAFFIC CONTROL DEVICES (BDE)**

Effective: March 2, 2020

Add the following to Article 701.03 of the Standard Specifications:

“(q) Temporary Sign Supports .....1106.02”

Revise the third paragraph of Article 701.14 of the Standard Specifications to read:

“For temporary sign supports, the Contractor shall provide a FHWA eligibility letter for each device used on the contract. The letter shall provide information for the set-up and use of the device as well as a detailed drawing of the device. The signs shall be supported within 20 degrees of vertical. Weights used to stabilize signs shall be attached to the sign support per the manufacturer’s specifications.”

Revise the first paragraph of Article 701.15 of the Standard Specifications to read:

“**701.15 Traffic Control Devices.** For devices that must meet crashworthiness standards, the Contractor shall provide a manufacturer’s self-certification or a FHWA eligibility letter for each Category 1 device and a FHWA eligibility letter for each Category 2 and Category 3 device used on the contract. The self-certification or letter shall provide information for the set-up and use of the device as well as a detailed drawing of the device.”

Revise the first six paragraphs of Article 1106.02 of the Standard Specifications to read:

“**1106.02 Devices.** Work zone traffic control devices and combinations of devices shall meet crashworthiness standards for their respective categories. The categories are as follows.

Category 1 includes small, lightweight, channelizing and delineating devices that have been in common use for many years and are known to be crashworthy by crash testing of similar devices or years of demonstrable safe performance. These include cones, tubular markers, plastic drums, and delineators, with no attachments (e.g. lights). Category 1 devices manufactured after December 31, 2019 shall be MASH-16 compliant. Category 1 devices manufactured on or before December 31, 2019, and compliant with NCHRP 350 or MASH 2009, may be used on contracts let before December 31, 2024.

Category 2 includes devices that are not expected to produce significant vehicular velocity change but may otherwise be hazardous. These include vertical panels with lights, barricades, temporary sign supports, and Category 1 devices with attachments (e.g. drums with lights). Category 2 devices manufactured after December 31, 2019 shall be MASH-16 compliant. Category 2 devices manufactured on or before December 31, 2019, and compliant with NCHRP 350 or MASH 2009, may be used on contracts let before December 31, 2024.

Category 3 includes devices that are expected to cause significant velocity changes or other potentially harmful reactions to impacting vehicles. These include crash cushions (impact

attenuators), truck mounted attenuators, and other devices not meeting the definitions of Category 1 or 2. Category 3 devices manufactured after December 31, 2019 shall be MASH-16 compliant. Category 3 devices manufactured on or before December 31, 2019, and compliant with NCHRP 350 or MASH 2009, may be used on contracts let before December 31, 2029. Category 3 devices shall be crash tested for Test Level 3 or the test level specified.

Category 4 includes portable or trailer-mounted devices such as arrow boards, changeable message signs, temporary traffic signals, and area lighting supports. It is preferable for Category 4 devices manufactured after December 31, 2019 to be MASH-16 compliant; however, there are currently no crash tested devices in this category, so it remains exempt from the NCHRP 350 or MASH compliance requirement.

For each type of device, when no more than one MASH-16 compliant is available, an NCHRP 350 or MASH-2009 compliant device may be used, even if manufactured after December 31, 2019."

Revise Articles 1106.02(g), 1106.02(k), and 1106.02(l) to read:

"(g) Truck Mounted/Trailer Mounted Attenuators. The attenuator shall be approved for use at Test Level 3. Test Level 2 may be used for normal posted speeds less than or equal to 45 mph.

(k) Temporary Water Filled Barrier. The water filled barrier shall be a lightweight plastic shell designed to accept water ballast and be on the Department's qualified product list.

Shop drawings shall be furnished by the manufacturer and shall indicate the deflection of the barrier as determined by acceptance testing; the configuration of the barrier in that test; and the vehicle weight, velocity, and angle of impact of the deflection test. The Engineer shall be provided one copy of the shop drawings.

(l) Movable Traffic Barrier. The movable traffic barrier shall be on the Department's qualified product list.

Shop drawings shall be furnished by the manufacturer and shall indicate the deflection of the barrier as determined by acceptance testing; the configuration of the barrier in that test; and the vehicle weight, velocity, and angle of impact of the deflection test. The Engineer shall be provided one copy of the shop drawings. The barrier shall be capable of being moved on and off the roadway on a daily basis."



Storm Water Pollution Prevention Plan

Route Charles Avenue
Section n/a
County DuPage

Marked Rte. Charles Avenue
Project No. n/a
Contract No.

This plan has been prepared to comply with the provisions of the National Pollutant Discharge Elimination System (NPDES) Permit No. ILR10 (Permit ILR10), issued by the Illinois Environmental Protection Agency (IEPA) for storm water discharges from construction site activities.

I certify under penalty of law that this document and all attachments were prepared under my direction or supervision in accordance with a system designed to assure that qualified personnel properly gathered and evaluated the information submitted. Based on my inquiry of the person or persons who manage the system, or those persons directly responsible for gathering the information, the information submitted is, to the best of my knowledge and belief, true, accurate and complete. I am aware that there are significant penalties for submitting false information, including the possibility of fine and imprisonment for knowing violations.

Kevin Mantels
Print Name
Assistant Village Engineer
Title
Village of Villa Park
Agency

Signature
Date

Note: Guidance on preparing each section of BDE 2342 can be found in Chapter 41 of the IDOT Bureau of Design and Environment Manual. Chapter 41 and this form also reference the IDOT Drainage Manual which should be readily available.

I. Site Description:

- A. Provide a description of the project location (include latitude and longitude, Section, Town, and Range): See Attachment A.
B. Provide a description of the construction activity which is the subject of this plan. Include the number of construction stages, drainage improvements, in-stream work, installation, maintenance, removal of erosion measures, and permanent stabilization: See Attachment A.
C. Provide the estimated duration of this project: 4 months
D. The total area of the construction site is estimated to be 1.81 acres. The total area of the site estimated to be disturbed by excavation, grading or other activities is 1.81 acres.
E. The following are weighted averages of the runoff coefficient for this project before and after construction activities are completed (See Section 4-102 of the IDOT Drainage Manual): C = 0.6 (Proposed); C = 0.6 (Existing)
F. List all soils found within project boundaries. Include map unit name, slope information, and erosivity: n/a
G. If wetlands were delineated for this project, provide an extent of wetland acreage at the site (See Phase I report): n/a
H. Provide a description of potentially erosive areas associated with this project: See Attachment A.

I. The following is a description of soil disturbing activities by stages, their locations, and their erosive factors (e.g., steepness of slopes, length of slopes, etc.):

See Attachment A.

J. See the erosion control plans and/or drainage plans for this contract for information regarding drainage patterns, approximate slopes anticipated before and after major grading activities, locations where vehicles enter or exit the site and controls to prevent offsite sediment tracking (to be added after contractor identifies locations), areas of soil disturbance, the location of major structural and non-structural controls identified in the plan, the location of areas where stabilization practices are expected to occur, surface waters (including wetlands) and locations where storm water is discharged to surface water including wetlands.

K. Identify who owns the drainage system (municipality or agency) this project will drain into:

Village of Villa Park

L. The following is a list of General NPDES ILR40 permittees within whose reporting jurisdiction this project is located.

Village of Villa Park

M. The following is a list of receiving water(s) and the ultimate receiving water(s) for this site. In addition, include receiving waters that are listed as Biologically Significant Streams by the IDNR. The location of the receiving waters can be found on the erosion and sediment control plans:

Salt Creek

N. Describe areas of the site that are to be protected or remain undisturbed. These areas may include steep slopes (i.e., 1:3 or steeper), highly erodible soils, streams, stream buffers, specimen trees, natural vegetation, nature preserves, etc. Include any commitments or requirements to protect adjacent wetlands.

For any storm water discharges from construction activities within 50-feet of Waters of the US (except for activities for water-dependent structures authorized by a Section 404 permit, describe: a) How a 50-foot undisturbed natural buffer will be provided between the construction activity and the Waters of the United States, or b) How additional erosion and sediment controls will be provided within that area.

See Attachment A.

O. Per the Phase I document, the following sensitive environmental resources are associated with this project and may have the potential to be impacted by the proposed development. Further guidance on these resources is available in Section 41-4 of the BDE Manual.

303(d) Listed receiving waters for suspended solids, turbidity, or siltation

The name(s) of the listed water body, and identification of all pollutants causing impairment:

Provide a description of how erosion and sediment control practices will prevent a discharge of sediment resulting from a storm event equal to or greater than a twenty-five (25) year, twenty-four (24) hour rainfall event

Provide a description of the location(s) of direct discharge from the project site to the 303(d) water body:

Provide a description of the location(s) of any dewatering discharges to the MS4 and/or water body:

Applicable Federal, Tribal, State or Local Programs

Floodplain

Historic Preservation

Receiving waters with Total Maximum Daily Load (TMDL) for sediment, total suspended solids, turbidity or siltation

TMDL (fill out this section if checked above)

The name(s) of the listed water body:

Provide a description of the erosion and sediment control strategy that will be incorporated into the site design that is consistent with the assumptions and requirements of the TMDL:

If a specific numeric waste load allocation has been established that would apply to the project's discharges, provide a description of the necessary steps to meet that allocation:

- Threatened and Endangered Species/Illinois Natural Areas (INA)/Nature Preserves
- Other
- Wetland

P. The following pollutants of concern will be associated with this construction project:

- |  |  |
|--|--|
| <input checked="" type="checkbox"/> Antifreeze / Coolants  | <input checked="" type="checkbox"/> Solid Waste Debris                               |
| <input checked="" type="checkbox"/> Concrete   | <input type="checkbox"/> Solvents  |
| <input checked="" type="checkbox"/> Concrete Curing Compounds                                      | <input checked="" type="checkbox"/> Waste water from cleaning construction equipment |
| <input checked="" type="checkbox"/> Concrete Truck Waste   | <input type="checkbox"/> Other (specify)   |
| <input checked="" type="checkbox"/> Fertilizers / Pesticides                                       | <input type="checkbox"/> Other (specify)   |
| <input checked="" type="checkbox"/> Paints   | <input type="checkbox"/> Other (specify)   |
| <input checked="" type="checkbox"/> Petroleum (gas, diesel, oil, kerosene, hydraulic oil / fluids) | <input type="checkbox"/> Other (specify)   |
| <input checked="" type="checkbox"/> Soil Sediment  | <input type="checkbox"/> Other (specify)   |

**II. Controls:**

This section of the plan addresses the controls that will be implemented for each of the major construction activities described in I.C. above and for all use areas, borrow sites, and waste sites. For each measure discussed, the Contractor will be responsible for its implementation as indicated. The Contractor shall provide to the Resident Engineer a plan for the implementation of the measures indicated. The Contractor, and subcontractors, will notify the Resident Engineer of any proposed changes, maintenance, or modifications to keep construction activities compliant with the Permit ILR10. Each such Contractor has signed the required certification on forms which are attached to, and are a part of, this plan:

- A. **Erosion and Sediment Controls:** At a minimum, controls must be coordinated, installed and maintained to:
1. Minimize the amount of soil exposed during construction activity;
  2. Minimize the disturbance of steep slopes;
  3. Maintain natural buffers around surface waters, direct storm water to vegetated areas to increase sediment removal and maximize storm water infiltration, unless infeasible;
  4. Minimize soil compaction and, unless infeasible, preserve topsoil.
- B. **Stabilization Practices:** Provided below is a description of interim and permanent stabilization practices, including site- specific scheduling of the implementation of the practices. Site plans will ensure that existing vegetation is preserved where attainable and disturbed portions of the site will be stabilized. Stabilization practices may include but are not limited to: temporary seeding, permanent seeding, mulching, geotextiles, sodding, vegetative buffer strips, protection of trees, preservation of mature vegetation, and other appropriate measures. Except as provided below in II(B)(1) and II(B)(2), stabilization measures shall be initiated **immediately** where construction activities have temporarily or permanently ceased, but in no case more than **one (1) day** after the construction activity in that portion of the site has temporarily or permanently ceases on all disturbed portions of the site where construction will not occur for a period of fourteen (14) or more calendar days.
1. Where the initiation of stabilization measures is precluded by snow cover, stabilization measures shall be initiated as soon as practicable.
  2. On areas where construction activity has temporarily ceased and will resume after fourteen (14) days, a temporary stabilization method can be used.

The following stabilization practices will be used for this project:

- Erosion Control Blanket / Mulching
- Temporary Turf (Seeding, Class 7)

- Geotextiles
- Permanent Seeding
- Preservation of Mature Vegetation
- Protection of Trees
- Sodding
- Temporary Erosion Control Seeding
- Temporary Mulching
- Vegetated Buffer Strips
- Other (specify)
- Other (specify)
- Other (specify)
- Other (specify)

Describe how the stabilization practices listed above will be utilized during construction:

See Attachment A.

Describe how the stabilization practices listed above will be utilized after construction activities have been completed:

See Attachment A.

C. **Structural Practices:** Provided below is a description of structural practices that will be implemented, to the degree attainable, to divert flows from exposed soils, store flows or otherwise limit runoff and the discharge of pollutants from exposed areas of the site. Such practices may include but are not limited to: perimeter erosion barrier, earth dikes, drainage swales, sediment traps, ditch checks, subsurface drains, pipe slope drains, level spreaders, storm drain inlet protection, rock outlet protection, reinforced soil retaining systems, gabions, and temporary or permanent sediment basins. The installation of these devices may be subject to Section 404 of the Clean Water Act.

The following structural practices will be used for this project:

- Aggregate Ditch
- Concrete Revetment Mats
- Dust Suppression
- Dewatering Filtering
- Gabions
- In-Stream or Wetland Work
- Level Spreaders
- Paved Ditch
- Permanent Check Dams
- Perimeter Erosion Barrier
- Permanent Sediment Basin
- Retaining Walls
- Riprap
- Rock Outlet Protection
- Sediment Trap
- Storm Drain Inlet Protection
- Stabilized Construction Exits
- Stabilized Trench Flow
- Slope Mattress
- Slope Walls
- Temporary Ditch Check
- Temporary Pipe Slope Drain
- Temporary Sediment Basin
- Temporary Stream Crossing
- Turf Reinforcement Mats
- Other (specify)
- Other (specify)
- Other (specify)
- Other (specify)
- Other (specify)
- Other (specify)
- Other (specify)

Describe how the structural practices listed above will be utilized during construction:

See Attachment A.

Describe how the structural practices listed above will be utilized after construction activities have been completed:

n/a

D. **Treatment Chemicals**

Will polymer flocculants or treatment chemicals be utilized on this project:  Yes  No

If yes above, identify where and how polymer flocculants or treatment chemicals will be utilized on this project.

E. **Permanent (i.e., Post-Construction) Storm Water Management Controls:** Provided below is a description of measures that will be installed during the construction process to control volume and pollutants in storm water discharges that will occur after construction operations have been completed. The installation of these devices may be subject to Section 404 of the Clean Water Act.

1. Such practices may include but are not limited to: storm water detention structures (including wet ponds), storm water retention structures, flow attenuation by use of open vegetated swales and natural depressions, infiltration of runoff on site, and sequential systems (which combine several practices).

The practices selected for implementation were determined based on the technical guidance in Chapter 41 (Construction Site Storm Water Pollution Control) of the IDOT Bureau of Design and Environment Manual. If practices other than those discussed in Chapter 41 are selected for implementation or if practices are applied to situations different from those covered in Chapter 41, the technical basis for such decisions will be explained below.

2. Velocity dissipation devices will be placed at discharge locations and along the length of any outfall channel as necessary to provide a non-erosive velocity flow from the structure to a water course so that the natural physical and biological characteristics and functions are maintained and protected (e.g., maintenance of hydrologic conditions such as the hydroperiod and hydrodynamics present prior to the initiation of construction activities).

Description of permanent storm water management controls:

Check valve backflow preventer in storm sewer at Charles Avenue.

- F. **Approved State or Local Laws:** The management practices, controls and provisions contained in this plan will be in accordance with IDOT specifications, which are at least as protective as the requirements contained in the Illinois Environmental Protection Agency's Illinois Urban Manual. Procedures and requirements specified in applicable sediment and erosion site plans or storm water management plans approved by local officials shall be described or incorporated by reference in the space provided below. Requirements specified in sediment and erosion site plans, site permits, storm water management site plans or site permits approved by local officials that are applicable to protecting surface water resources are, upon submittal of an NOI, to be authorized to discharge under the Permit ILR10 incorporated by reference and are enforceable under this permit even if they are not specifically included in the plan.

Description of procedures and requirements specified in applicable sediment and erosion site plans or storm water management plans approved by local officials:

See plans.

- G. **Contractor Required Submittals:** Prior to conducting any professional services at the site covered by this plan, the Contractor and each subcontractor responsible for compliance with the permit shall submit to the Resident Engineer a Contractor Certification Statement, BDE 2342a.

1. The Contractor shall provide a construction schedule containing an adequate level of detail to show major activities with implementation of pollution prevention BMPs, including the following items:

- Approximate duration of the project, including each stage of the project
- Rainy season, dry season, and winter shutdown dates
- Temporary stabilization measures to be employed by contract phases
- Mobilization timeframe
- Mass clearing and grubbing/roadside clearing dates
- Deployment of Erosion Control Practices
- Deployment of Sediment Control Practices (including stabilized construction entrances/exits)
- Deployment of Construction Site Management Practices (including concrete washout facilities, chemical storage, refueling locations, etc.)
- Paving, saw-cutting, and any other pavement related operations
- Major planned stockpiling operations
- Timeframe for other significant long-term operations or activities that may plan non-storm water discharges such as dewatering, grinding, etc.
- Permanent stabilization activities for each area of the project

2. During the pre-construction meeting, the Contractor and each subcontractor shall provide, as an attachment to their signed Contractor Certification Statement, a discussion of how they will comply with the requirements of the permit in regard to the following items and provide a graphical representation showing location and type of BMPs to be used when applicable:

- Temporary Ditch Checks - Identify what type and the source of Temporary Ditch Checks that will be installed as part of the project. The installation details will then be included with the SWPPP.

- Vehicle Entrances and Exits – Identify type and location of stabilized construction entrances and exits to be used and how they will be maintained.
- Material Delivery, Storage and Use – Discuss where and how materials including chemicals, concrete curing compounds, petroleum products, etc. will be stored for this project.
- Stockpile Management – Identify the location of both on-site and off-site stockpiles. Discuss what BMPs will be used to prevent pollution of storm water from stockpiles.
- Waste Disposal – Discuss methods of waste disposal that will be used for this project.
- Spill Prevention and Control – Discuss steps that will be taken in the event of a material spill (chemicals, concrete curing compounds, petroleum, etc.)
- Concrete Residuals and Washout Wastes – Discuss the location and type of concrete washout facilities to be used on this project and how they will be signed and maintained.
- Litter Management – Discuss how litter will be maintained for this project (education of employees, number of dumpsters, frequency of dumpster pick-up, etc.).
- Vehicle and Equipment Fueling – Identify equipment fueling locations for this project and what BMPs will be used to ensure containment and spill prevention.
- Vehicle and Equipment Cleaning and Maintenance – Identify where equipment cleaning and maintenance locations for this project and what BMPs will be used to ensure containment and spill prevention.
- Dewatering Activities – Identify the controls which will be used during dewatering operations to ensure sediments will not leave the construction site.
- Polymer Flocculants and Treatment Chemicals – Identify the use and dosage of treatment chemicals and provide the Resident Engineer with Material Safety Data Sheets. Describe procedures on how the chemicals will be used and identify who will be responsible for the use and application of these chemicals. The selected individual must be trained on the established procedures.
- Additional measures indicated in the plan.

### III. Maintenance:

When requested by the Contractor, the Resident Engineer will provide general maintenance guides (e.g., IDOT Erosion and Sediment Control Field Guide) to the Contractor for the practices associated with this project. Describe how all items will be checked for structural integrity, sediment accumulation and functionality. Any damage or undermining shall be repaired immediately. Provide specifics on how repairs will be made. The following additional procedures will be used to maintain, in good and effective operating conditions, the vegetation, erosion and sediment control measures and other protective measures identified in this plan. It will be the Contractor's responsibility to attain maintenance guidelines for any manufactured BMPs which are to be installed and maintained per manufacture's specifications.

See Attachment A.

### IV. Inspections:

Qualified personnel shall inspect disturbed areas of the construction site including Borrow, Waste, and Use Areas, which have not yet been finally stabilized, structural control measures, and locations where vehicles and equipment enter and exit the site using IDOT Storm Water Pollution Prevention Plan Erosion Control Inspection Report (BC 2259). Such inspections shall be conducted at least once every seven (7) calendar days and within twenty-four (24) hours of the end of a storm or by the end of the following business or work day that is 0.5 inch or greater or equivalent snowfall.

Inspections may be reduced to once per month when construction activities have ceased due to frozen conditions. Weekly inspections will recommence when construction activities are conducted, or if there is 0.5" or greater rain event, or a discharge due to snowmelt occurs.

If any violation of the provisions of this plan is identified during the conduct of the construction work covered by this plan, the Resident Engineer shall notify the appropriate IEPA Field Operations Section office by email at: [epa.swnoncomp@illinois.gov](mailto:epa.swnoncomp@illinois.gov), telephone or fax within twenty-four (24) hours of the incident. The Resident Engineer shall then complete and submit an "Incidence of Non-Compliance" (ION) report for the identified violation within five (5) days of the incident. The Resident Engineer shall use forms provided by IEPA and shall include specific information on the cause of noncompliance, actions which were taken to prevent any further causes of noncompliance, and a statement detailing any environmental impact which may have resulted from the noncompliance. All reports of non-compliance shall be signed by a responsible authority in accordance with Part VI. G of the Permit ILR10.

The Incidence of Non-Compliance shall be mailed to the following address:

Illinois Environmental Protection Agency  
Division of Water Pollution Control  
Attn: Compliance Assurance Section  
1021 North Grand East

Post Office Box 19276  
Springfield, Illinois 62794-9276

**V. Failure to Comply:**

Failure to comply with any provisions of this Storm Water Pollution Prevention Plan will result in the implementation of a National Pollutant Discharge Elimination System/Erosion and Sediment Control Deficiency Deduction against the Contractor and/or penalties under the Permit ILR10 which could be passed on to the Contractor.



**Storm Water Pollution Prevention Plan  
Attachment A  
Charles Avenue  
DuPage County  
Section**

**I. Site Description:**

**A. Provide a description of the project location (include latitude and longitude):**

The project is located on Charles Avenue, beginning at St. Charles Road and ending at Oak Street. The total net and gross length of the project is 1,312.00 feet (0.248 mile) for the reconstruction and realignment of Charles Avenue in the Village of Villa Park, DuPage County. The project is located at 41° 53' 30" N and 87° 58' 30" W.

**B. Provide a description of the construction activity which is the subject of this plan:**

The project includes the reconstruction and realignment of Charles Avenue. The work to be performed under this contract consists of pavement removal, earth excavation, aggregate subgrade improvement, HMA full-depth pavement, PCC curb and gutter, PCC sidewalk, pavement markings, erosion and sediment control, traffic control and protection, water main, combined sewer separation, storm sewer and structures, and landscaping.

Erosion and sediment control measures for the project include the use of temporary seeding, erosion control blanket, perimeter erosion barrier, dust control watering, inlet filters, and sodding.

**H. Provide a description of potentially erosive areas associated with this project:**

The ends of Charles Avenue (St. Charles Road and Oak Street) each slope toward the intersection with Elm Street. There is potential for eroded soil to inundate storm sewer inlets at the intersection.

**I. The following is a description of soil disturbing activities by stages, their locations, and their erosive factors (e.g. steepness of slopes, length of slopes, etc):**

The project consists of one construction stage.

1. Installation of storm sewer, water main, combined sewer repair, and structures.
2. Pavement removal.
3. Existing topsoil will be stripped and removed from the site.
4. Grading.
5. Installation of the subgrade, curb and gutter, and pavement.

**N. Describe areas of the site that are to be protected or remain undisturbed. These areas may include steep slopes, highly erodible soils, streams, stream buffers, specimen trees, natural vegetation, nature preserves, etc.**

Areas that are protected with perimeter erosion control barrier shall remain undisturbed throughout the duration of the project.

**Storm Water Pollution Prevention Plan  
Attachment A  
Charles Avenue  
DuPage County  
Section**

**II. Controls**

**B. Stabilization Practices**

**Describe how the stabilization practices listed above will be utilized during construction:**

Excavated areas shall be either permanently sodded once final gradation has taken place, as shown on the plans. If not, they shall be temporarily seeded in accordance with the Standard Specifications for Road and Bridge Construction.

Stabilization controls runoff volume and velocity, peak runoff rates, and volumes of discharge to minimize exposed soil, disturbed slopes, and sediment discharges from construction, and it provides for natural buffers and minimization of soil compaction. Existing vegetated areas where disturbance can be avoided will not require stabilization.

**Describe how the stabilization practices listed above will be utilized after construction activities have been completed:**

The temporary erosion control system will be removed, and permanent erosion control items will be installed as shown on the plans. Maintenance and repair of these items shall be the responsibility of the Contractor prior to completion of the project. Upon completion of the project, the maintenance and repair of the permanent erosion control items shall be the responsibility of the Village of Villa Park.

**C. Structural Practices**

**Describe how the structural practices listed above will be utilized during construction:**

Perimeter erosion barrier will be installed at the beginning of construction and remain for the duration of the project. Perimeter erosion barrier will reduce the potential for untreated runoff to flow offsite. Perimeter erosion barrier will be comprised of silt fence. Silt fence will be used as perimeter erosion barrier in areas where there is the potential for erosion and sediment to sheet flow offsite.

Storm drain inlet protection will be installed on existing and proposed storm sewer structures within the curb and gutter. Storm drain inlet and pipe protection will be installed on existing and proposed storm sewer structures and culverts within the parkways and ditches. Both measures will be used to treat runoff from the jobsite and reduce the potential for offsite contamination.

**Storm Water Pollution Prevention Plan  
Attachment A  
Charles Avenue  
DuPage County  
Section**

**E. Description of Permanent Stormwater Management Controls:**

All existing storm sewer lines on site will be protected during construction to ensure no debris flows into the system. All existing storm sewer lines and structures on site will then be removed. A new storm sewer system will replace the existing system. This new system will also be protected during construction to prevent debris from entering the system.

**III. Maintenance:**

All erosion and sediment control measures will be maintained in accordance with the IDOT Erosion and Sediment Control Field Guide for Construction Inspection.

All erosion and sediment control measures should be checked weekly and after each rainfall 0.5 inch or greater in a 24-hour period or equivalent snowfall. Additionally, during winter months, all measures should be checked after each significant snowmelt.

All offsite borrow, waste, and use areas are part of the construction site and are to be inspected according to the language in this section.

- (a) Perimeter Erosion Barrier—Barrier shall be installed prior to any earth-disturbing activities. It shall have no tears or gaps and must not be leaning. Any stakes that are missing or broken must be replaced immediately. If the sediment reaches one-third the height of the barrier, maintenance or replacement is required. Repair the barrier if undermining occurs anywhere along its entire length. Remove the barrier once final stabilization is established.
- (b) Inlet Protection—Remove sediment from inlet filter basket when basket is 25% full or when 50% of the fabric pores are covered with silt. Remove ponded water on road surfaces immediately. Clean filter if standing water is present longer than one hour after a rain event. Remove trash accumulated around or on top of protection. When a filter is removed for cleaning, replace filter if any tear is present.
- (c) Temporary Seeding—A visual inspection of this item is necessary to determine whether it has germinated. If the seed has failed to germinate, another application of seed may be necessary. Restore rills greater than 4 inches deep as quickly as possible on slopes steeper than 1V:4H to prevent the sheet-flow from becoming concentrated flow patterns. If excessive weed development occurs, mowing may be necessary.
- (d) Permanent Sodding—A visual inspection of this item is necessary to determine whether it has germinated. If the sod has failed to germinate, another application might be necessary.
- (e) Erosion Control Blanket—Repair damage from water running beneath the blanket and restore blanket when displacement occurs. Reseeding may be necessary. Replace all displaced blankets and restaple.



1021 North Grand Avenue East • P.O. Box 19276 • Springfield • Illinois • 62794-9276 • (217) 782-3397

**Division of Water Pollution Control  
Notice of Intent (NOI) for General Permit  
to Discharge Storm Water Associated with Construction Site Activities**

*This fillable form may be completed online, a copy saved locally, printed and signed before it is submitted to the Permit Section at the above address.*

For Office Use Only

**OWNER INFORMATION**

Permit No. ILR10 \_\_\_\_\_

Company/Owner Name: Village of Villa Park  
Mailing Address: 20 South Ardmore Avenue Phone: 630-834-8505  
City: Villa Park State: IL Zip: 60181 Fax: 630-834-8509  
Contact Person: Kevin Mantels E-mail: kmantels@invillapark.com  
Owner Type (select one) City

**CONTRACTOR INFORMATION**

MS4 Community:  Yes  No

Contractor Name: \_\_\_\_\_  
Mailing Address: \_\_\_\_\_ Phone: \_\_\_\_\_  
City: \_\_\_\_\_ State: \_\_\_\_\_ Zip: \_\_\_\_\_ Fax: \_\_\_\_\_

**CONSTRUCTION SITE INFORMATION**

Select One:  New  Change of information for: ILR10 \_\_\_\_\_  
Project Name: Charles Avenue Improvements Project County: DuPage  
Street Address: Elm Street and Charles Avenue City: Villa Park IL Zip: 60181  
Latitude: 41 53 30 Longitude: -87 58 30 3 39N 11E  
(Deg) (Min) (Sec) (Deg) (Min) (Sec) Section Township Range  
Approximate Construction Start Date Jul 16, 2021 Approximate Construction End Date Oct 29, 2021

Total size of construction site in acres: 1.75

If less than 1 acre, is the site part of a larger common plan of development?  
 Yes  No

Fee Schedule for Construction Sites:  
Less than 5 acres - \$250  
5 or more acres - \$750

**STORM WATER POLLUTION PREVENTION PLAN (SWPPP)**

Has the SWPPP been submitted to the Agency?  Yes  No

(Submit SWPPP electronically to: [epa.constilr10swppp@illinois.gov](mailto:epa.constilr10swppp@illinois.gov))

Location of SWPPP for viewing: Address: 20 South Ardmore Avenue City: Villa Park

SWPPP contact information: Inspector qualifications: \_\_\_\_\_

Contact Name: Kevin Mantels

Phone: 630-834-8505 Fax: 630-834-8509 E-mail: kmantels@invillapark.com

Project inspector, if different from above Inspector qualifications: \_\_\_\_\_

Inspector's Name: Kyle Troka P.E. \_\_\_\_\_

Phone: 815-744-4200 Fax: 815-744-4215 E-mail: kyle.troka@strand.com

This Agency is authorized to require this information under Section 4 and Title X of the Environmental Protection Act (415 ILCS 5/4, 5/39). Failure to disclose this information may result in: a civil penalty of not to exceed \$50,000 for the violation and an additional civil penalty of not to exceed \$10,000 for each day during which the violation continues (415 ILCS 5/42) and may also prevent this form from being processed and could result in your application being denied. This form has been approved by the Forms Management Center.

**TYPE OF CONSTRUCTION (select one)**

Construction Type Reconstruction

SIC Code: \_\_\_\_\_

Type a detailed description of the project:

The work consists of removing the existing pavement and replacing it with full-depth hot mix asphalt pavement, combination curb and gutter, sidewalk, pavement markings, landscaping, storm sewer and structures, water main, and other miscellaneous items to be constructed along the length of the project.

**HISTORIC PRESERVATION AND ENDANGERED SPECIES COMPLIANCE**

Has the project been submitted to the following state agencies to satisfy applicable requirements for compliance with Illinois law on:

Historic Preservation Agency       Yes       No      <http://www.illinoishistory.gov/PS/rcdocument.htm>

Endangered Species       Yes       No      <http://dnr.illinois.gov/ecopublic/>

**RECEIVING WATER INFORMATION**

Does your storm water discharge directly to:     Waters of the State    or     Storm Sewer

Owner of storm sewer system: Village of Villa Park

Name of closest receiving water body to which you discharge: Salt Creek

Mail completed form to: Illinois Environmental Protection Agency  
Division of Water Pollution Control  
Attn: Permit Section  
Post Office Box 19276  
Springfield, Illinois 62794-9276  
or call (217) 782-0610  
FAX: (217) 782-9891

Or submit electronically to: [epa.constilr10swppp@illinois.gov](mailto:epa.constilr10swppp@illinois.gov)

I certify under penalty of law that this document and all attachments were prepared under my direction and supervision in accordance with a system designed to assure that qualified personnel properly gather and evaluate the information submitted. Based on my inquiry of the person or persons who manage this system, or those persons directly responsible for gathering the information, the information submitted is, to the best of my knowledge and belief, true, accurate, and complete. I am aware that there are significant penalties for submitting false information, including the possibility of fine and imprisonment. In addition, I certify that the provisions of the permit, including the development and implementation of a storm water pollution prevention plan and a monitoring program plan, will be complied with.

**Any person who knowingly makes a false, fictitious, or fraudulent material statement, orally or in writing, to the Illinois EPA commits a Class 4 felony. A second or subsequent offense after conviction is a Class 3 felony. (415 ILCS 5/44(h))**

Owner Signature: \_\_\_\_\_

Kevin Mantels  
Printed Name:

Date: \_\_\_\_\_

Assistant Village Engineer  
Title:

**INSTRUCTIONS FOR COMPLETION OF CONSTRUCTION ACTIVITY NOTICE OF INTENT (NOI) FORM**

Submit original, electronic or facsimile copies. Facsimile and/or electronic copies should be followed-up with submission of an original signature copy as soon as possible. Please write "copy" under the "For Office Use Only" box in the upper right hand corner of the first page.

***This fillable form may be completed online, a copy saved locally, printed and signed before it is submitted to the Permit Section at:***

Illinois Environmental Protection Agency  
Division of Water Pollution Control  
Permit Section  
Post Office Box 19276  
Springfield, Illinois 62794-9276  
or call (217) 782-0610

FAX: (217) 782-9891

Or submit electronically to: [epa.constilr10swppp@illinois.gov](mailto:epa.constilr10swppp@illinois.gov)

**Reports must be typed or printed legibly and signed.**

Any facility that is not presently covered by the General NPDES Permit for Storm Water Discharges From Construction Site Activities is considered a new facility.

If this is a change in your facility information, renewal, etc., please fill in your permit number on the appropriate line, changes of information or permit renewal notifications do not require a fee.

**NOTE: FACILITY LOCATION IS NOT NECESSARILY THE FACILITY MAILING ADDRESS, BUT SHOULD DESCRIBE WHERE THE FACILITY IS LOCATED.**

Use the formats given in the following examples for correct form completion.

	Example	Format
Section	12	1 or 2 numerical digits
Township	12N	1 or 2 numerical digits followed by "N" or "S"
Range	12W	1 or 2 numerical digits followed by "E" or "W"

For the Name of Closest Receiving Waters, do not use terms such as ditch or channel. For unnamed tributaries, use terms which include at least a named main tributary such as "Unnamed Tributary to Sugar Creek to Sangamon River."

Submission of initial fee and an electronic submission of Storm Water Pollution Prevention Plan (SWPPP) for Initial Permit prior to the Notice of Intent being considered complete for coverage by the ILR10 General Permits. Please make checks payable to: Illinois EPA at the above address.

Construction sites with less than 5 acres of land disturbance - fee is \$250.

Construction sites with 5 or more acres of land disturbance - fee is \$750.

SWPPP should be submitted electronically to: [epa.constilr10swppp@illinois.gov](mailto:epa.constilr10swppp@illinois.gov). When submitting electronically, use Project Name and City as indicated on NOI form.

**APPENDIX B**

**IDOT HIGHWAY STANDARDS AND DISTRICT ONE DETAILS**



ABV ABOVE	CU YD CUBIC YARD	HATCH HATCHING	PM PAVEMENT MARKING	STD STANDARD
A/C ACCESS CONTROL	CULV CULVERT	HD HEAD	PED PEDESTAL	SBI STATE BOND ISSUE
AC ACRE	C&G CURB & GUTTER	HDW HEADWALL	PNT POINT	SR STATE ROUTE
ADJ ADJUST	D DEGREE OF CURVE	HDUTY HEAVY DUTY	PC POINT OF CURVATURE	STA STATION
AS AERIAL SURVEYS	DC DEPRESSED CURVE	ha HECTARE	PI POINT OF INTERSECTION OF HORIZONTAL CURVE	SPBGR STEEL PLATE BEAM GUARDRAIL
AGG AGGREGATE	DET DETECTOR	HMA HOT MIX ASPHALT	PRC POINT OF REVERSE CURVE	SS STORM SEWER
AH AHEAD	DIA DIAMETER	HWY HIGHWAY	PT POINT OF TANGENCY	STY STORY
APT APARTMENT	DIST DISTRICT	HORIZ HORIZONTAL	POT POINT ON TANGENT	ST STREET
ASPH ASPHALT	DOM DOMESTIC	HSE HOUSE	POLYETH POLYETHYLENE	STR STRUCTURE
AUX AUXILIARY	DBL DOUBLE	IL ILLINOIS	PCC PORTLAND CEMENT CONCRETE	e SUPERELEVATION RATE
AGS AUXILIARY GAS VALVE (SERVICE)	DSEL DOWNSTREAM ELEVATION	IMP IMPROVEMENT	PP PORTLAND CEMENT CONCRETE	S.E. RUN SUPERELEVATION RUNOFF LENGTH
AVE AVENUE	DSFL DOWNSTREAM FLOWLINE	IN DIA INCH DIAMETER	PP POWER POLE OR PRINCIPAL POINT	SURF SURFACE
AX AXIS OF ROTATION	DR DRAINAGE OR DRIVE	INL INLET	PRM PRIME	SMK SURVEY MARKER
BK BACK	DI DRAINAGE INLET OR DROP INLET	INST INSTALLATION	PE PRIVATE ENTRANCE	T TANGENT DISTANCE
B-B BACK TO BACK	DRV DRIVEWAY	IDS INTERSECTION DESIGN STUDY	PROF PROFILE	T.R TANGENT RUNOUT DISTANCE
BKPL BACKPLATE	DCT DUCT	INV INVERT	PGL PROFILE GRADELINE	TEL TELEPHONE
B BARN	EA EACH	IP IRON PIPE	PROJ PROJECT	TB TELEPHONE BOX
BARR BARRICADE	EB EASTBOUND	IR IRON ROD	P.C. PROPERTY CORNER	TP TELEPHONE POLE
BL BASELINE	EOP EDGE OF PAVEMENT	JT JOINT	PL PROPERTY LINE	TEMP TEMPORARY
BGN BEGIN	E-CL EDGE TO CENTERLINE	kg KILOGRAM	PR PROPOSED	TBM TEMPORARY BENCH MARK
BM BENCHMARK	E-E EDGE TO EDGE	km KILOMETER	R RADIUS or RESIDENTIAL	TD TILE DRAIN
BIND BINDER	ELEC ELECTRICAL	LS LANDSCAPING	RR RAILROAD	TBE TO BE EXTENDED
BIT BITUMINOUS	EL ELEVATION	LN LANE	RRS RAILROAD SPIKE	TBR TO BE REMOVED
BTM BOTTOM	ENR ENTRANCE	LT LEFT	RPS REFERENCE POINT STAKE	TBS TO BE SAVED
BLVD BOULEVARD	EXC EXCAVATION	LIDAR LIGHT DETECTION AND RANGING	REF REFLECTIVE	TWP TOWNSHIP
BRK BRICK	EX EXISTING	LP LIGHT POLE	RCCP REINFORCED CONCRETE CULVERT PIPE	TR TOWNSHIP ROAD
BBOX BUFFALO BOX	EXPWAY EXPRESSWAY	LGT LIGHTING	REINF REINFORCEMENT	TS TRAFFIC SIGNAL
BLDG BUILDING	E EXTERNAL DISTANCE OF HORIZONTAL CURVE	LF LINEAL FEET OR LINEAR FEET	REM REMOVAL	TSCB TRAFFIC SIGNAL CONTROL BOX
CATV CABLE	E OFFSET DISTANCE TO VERTICAL CURVE	L LITER OR CURVE LENGTH	RC REMOVE CROWN	TSC TRAFFIC SIGNAL CENTER
CIP CAST IRON PIPE	F-F FACE TO FACE	LC LONG CHORD	REP REPLACEMENT	TRVS TRANSVERSE
CB CATCH BASIN	FA FEDERAL AID	LNG LONGITUDINAL	REST RESTAURANT	TRVL TRAVEL
C-C CENTER TO CENTER	FAI FEDERAL AID INTERSTATE	L SUM LUMP SUM	RESURF RESURFACING	TRN TURN
CL CENTERLINE OR CLEARANCE	FAP FEDERAL AID PRIMARY	MACH MACHINE	RET RETAINING	TY TYPE
CL-E CENTERLINE TO EDGE	FA5 FEDERAL AID SECONDARY	MB MAIL BOX	RT RIGHT	T-A TYPE A
CL-F CENTERLINE TO FACE	FAUS FEDERAL AID URBAN SECONDARY	MH MANHOLE	ROW RIGHT-OF-WAY	TYP TYPICAL
CTS CENTERS	FP FENCE POST	MATL MATERIAL	RD ROAD	UNDGND UNDERGROUND
CERT CERTIFIED	OPT OPTIC	MED MEDIAN	RDWY ROADWAY	USGS U.S. GEOLOGICAL SURVEY
CHSLD CHISELED	FE FIELD ENTRANCE	m METER	RTE ROUTE	USEL UPSTREAM ELEVATION
CS CITY STREET	FH FIRE HYDRANT	METH METHOD	SAN SANITARY	USFL UPSTREAM FLOWLINE
CP CLAY PIPE	FL FLOW LINE	M MID-ORDINATE	SANS SANITARY SEWER	UTIL UTILITY
CLSD CLOSED	FB FOOT BRIDGE	mm MILLIMETER	SEC SECTION	VBOX VALVE BOX
CLID CLOSED LID	FDN FOUNDATION	mm DIA MILLIMETER DIAMETER	SEED SEEDING	VV VALVE VAULT
CT COAT OR COURT	FR FRAME	MIX MIXTURE	SHAP SHAPING	VLT VAULT
COMB COMBINATION	F&G FRAME & GRATE	MBH MOBILE HOME	S SHED	VEH VEHICLE
C COMMERCIAL BUILDING	FRWAY FREEWAY	MDD MODIFIED	SH SHEET	VP VENT PIPE
CE COMMERCIAL ENTRANCE	GAL GALLON	MFT MOTOR FUEL TAX	SHLD SHOULDER	VERT VERTICAL
CONC CONCRETE	GALV GALVANIZED	N & BC NAIL & BOTTLE CAP	SHLW SIDEWALK OR SOUTHWEST	VC VERTICAL CURVE
CONST CONSTRUCT	G GARAGE	N & C NAIL & CAP	SIG SIGNAL	VPC VERTICAL POINT OF CURVATURE
CONTD CONTINUED	GM GAS METER	N & W NAIL & WASHER	SOD SODDING	VPI VERTICAL POINT OF INTERSECTION
CONT CONTINUOUS	GV GAS VALVE	NC NORMAL CROWN	SM SOLID MEDIUM	VPT VERTICAL POINT OF TANGENCY
COR CORNER	GIS GEOGRAPHICAL INFORMATION SYSTEM	NB NORTHBOUND	SB SOUTHBOUND	WM WATER METER
CORR CORRUGATED	GRAN GRANULAR	NE NORTHEAST	SE SOUTHEAST	WV WATER VALVE
CMP CORRUGATED METAL PIPE	GR GRATE	NW NORTHWEST	SPL SPECIAL	WMAIN WATER MAIN
CNTY COUNTY	GRVL GRAVEL	O/S OFFSET	SD SPECIAL DITCH	WB WESTBOUND
CH COUNTY HIGHWAY	GND GROUND	O&C OIL AND CHIP	SQ FT SQUARE FEET	WILDFL WILDFLOWERS
CSE COURSE	GUT GUTTER	OLID OPEN LID	m <sup>2</sup> SQUARE METER	W WITH
XSECT CROSS SECTION	GP GUY POLE	PAT PATTERN	mm <sup>2</sup> SQUARE MILLIMETER	WO WITHOUT
m <sup>3</sup> CUBIC METER	GW GUY WIRE	PVD PAVED	SQ YD SQUARE YARD	
mm <sup>3</sup> CUBIC MILLIMETER	HH HANDHOLE	PVMT PAVEMENT	STB STABILIZED	

Illinois Department of Transportation

DESIGNED BY: [Signature] DATE: 1/1/21

CHECKED BY: [Signature] DATE: 1/1/21

APPROVED BY: [Signature] DATE: 1/1/21

4611-03/25

DATE	REVISIONS	STANDARD SYMBOLS, ABBREVIATIONS AND PATTERNS (Sheet 1 of 9)
1-1-21	Updated fonts, abbreviations and symbols.	
1-1-19	Added new symbols.	
		STANDARD 000001-08



**EROSION & SEDIMENT CONTROL ITEMS**

**EX**

**PR**

- Cleaning & Grading Limits
- Dike
- Erosion Control Fence
- Perimeter Erosion Barrier
- Temporary Fence

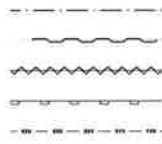

- Ditch Check Temporary
- Ditch Check Permanent



- Inlet & Pipe Protection
- Sediment Basin

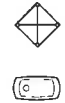

- Erosion Control Blanket
- Fabric Formed Concrete Revetment Mat

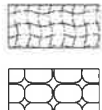

- Turf Reinforcement Mat
- Mulch Temporary

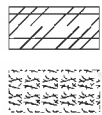

- Mulch Method 1
- Mulch Method 2 Stabilized

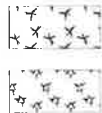

- Mulch Method 3 Hydraulic



**CONTOUR ITEMS**

**EX**

**PR**

- Approx. Index Line
- Approx. Intermediate Line
- Index Contour
- Intermediate Contour



Illinois Department of Transportation

PASSED January 1, 2021

INTEGRITY OF POLICY AND PROCEDURES

APPROVED January 2, 2021

ENGINEER OF DESIGN AND SURVEYING

FILE NUMBER

**NON-HIGHWAY IMPROVEMENT ITEMS**

**EX**

**PR**

- Noise Attenuation Levee
- Field Line
- Fence
- Base of Levee
- Mailbox
- Multiple Mailboxes
- Pay Telephone
- Advertising Sign
- ITS Camera
- Wind Turbine
- Cellular Tower
- Intelligent Transportation Systems

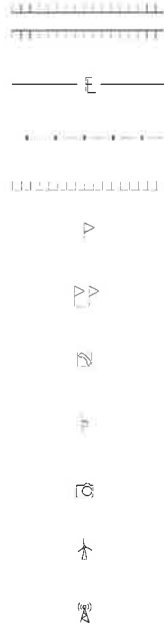

**LANDSCAPING ITEMS**

**EX**

**PR**

- Contour Mounding Line
- Fence
- Fence Post
- Shrubs
- Mowline
- Perennial Plants
- Seeding Class 2
- Seeding Class 2A
- Seeding Class 4
- Seeding Class 4 & 5 Combined

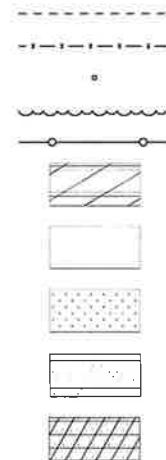

**EXISTING LANDSCAPING ITEMS (contd.)**

**EX**

**PR**

- Seeding Class 5
- Seeding Class 7
- Seedlings Type 1
- Seedlings Type 2
- Sodding
- Mowstake w/Sign



- Tree Trunk Protection
- Evergreen Tree
- Shade Tree

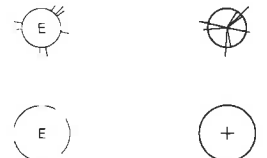

**LIGHTING**

**EX**

**PR**

- Duct
- Conduit
- Electrical Aerial Cable
- Electrical Buried Cable
- Controller
- Underpass Luminaire
- Power Pole

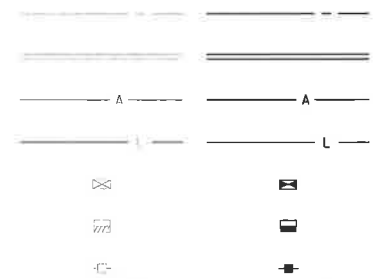

**STANDARD SYMBOLS, ABBREVIATIONS AND PATTERNS**  
(Sheet 3 of 9)

STANDARD 000001-08

**LIGHTING  
(contd.)**

**EX**

**PR**

Pull Point



Handhole



Heavy Duty Handhole



Junction Box



Light Unit Comb



Electrical Ground



Traffic Flow Arrow



High Mast Pole  
(Half Size)



Light Unit-1



**PAVEMENT (MISC.)**

**EX**

**PR**

Keyed Long Joint



Keyed Long Joint w/Tie Bars

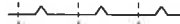
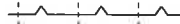

Sawed Long Joint w/Tie Bars



Bituminous Shoulder



Bituminous Taper



Stabilized Driveway



Widening



**PAVEMENT MARKINGS**

**EX**

**PR**

Handicap Symbol



RR Crossing



Raised Marker Amber 1 Way



Raised Marker Amber 2 Way



Raised Marker Crystal 1 Way



Two Way Turn Left



Shoulder Diag. Pattern



Skip-Dash White



Skip Dash Yellow



Stop Line



Solid Line



Double Centerline



Dotted Lines

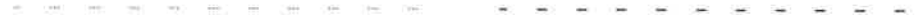

Illinois Department of Transportation

PASSER: [Signature] January 1, 2021

DESIGNER: [Signature] January 1, 2021

APPROVER: [Signature] January 1, 2021

ILLINOIS DEPARTMENT OF TRANSPORTATION

STATE OF ILLINOIS

**STANDARD SYMBOLS,  
ABBREVIATIONS  
AND PATTERNS**

[Sheet 4 of 9]

**STANDARD 000001-08**

**PAVEMENT MARKINGS**  
**(contd.)**

**EX**

**PR**

CL 2Ln 2Way  
RRPM 12.2 m (40') o.c.



CL 2Ln 2Way  
RRPM 80' (24.4 m) o.c.

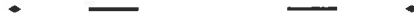

CL Multilane Div.  
RRPM 40' (12.2 m) o.c.



CL Multilane Div.  
RRPM 80' (24.4 m) o.c.



CL Multilane Div. Dbl.  
RRPM 80' (24.4 m) o.c.



CL Multilane Undiv.



Two Way Turn Left Line



Urban Combination Left



Urban Combination Right



Urban Left Turn Arrow



Urban Right Turn Arrow



Urban Left Turn Only



Urban Right Turn Only



Urban Thru Only

ONLY ONLY ONLY



Urban LT & RT Turn Arrow

Urban Thru Arrow

Illinois Department of Transportation

ISSUED January 1, 2021

MANAGER OF POLICY AND PROCEDURES

APPROVED January 1, 2021

ILLINOIS DEPARTMENT OF TRANSPORTATION

**RAILROAD ITEMS**

**EX**

**PR**

Abandoned Railroad



Railroad



Railroad Point



Control Box



Crossing Gate



Flashing Signal



Railroad Cant Mast Arm



Crossbuck



**REMOVAL ITEMS**

**EX**

**PR**

Removal Tic



Bituminous Removal



Hatch Pattern



Tree Removal Single



**RIGHT OF WAY ITEMS**

**EX**

**PR**

Future ROW Corner Monument



ROW Marker



ROW Line



Easement

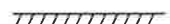

Temporary Easement

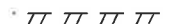

**STANDARD SYMBOLS,  
ABBREVIATIONS  
AND PATTERNS**  
(Sheet 5 of 9)

**STANDARD 000001-08**

**PAVEMENT MARKINGS**  
**(contd.)**

**EX**

Urban U-Turn

Urban Combined U-Turn

Rural Combination Left

Rural Combination Right

Rural Left Turn Arrow

Rural Right Turn Arrow

Rural Left Turn Only

Rural Right Turn Only

Rural Thru Only

Rural Thru Arrow

Rural Lt & Rt Turn Arrow

Bike Lane Symbol

Bike Lane Text

Bike Path Shared

Bike Shared Roadway

Lane Drop Symbol

ONLY ONLY ONLY

**PR**

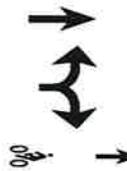
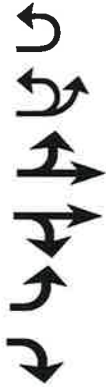

BIKE LANE

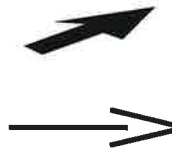

Illinois Department of Transportation	
PREPARED BY <i>[Signature]</i>	January 1, 2021
APPROVED BY <i>[Signature]</i>	January 1, 2021
ENGINEER OF DESIGN AND ENVIRONMENT	

Wrong Way Arrow

**STANDARD SYMBOLS,  
ABBREVIATIONS  
AND PATTERNS**

(Sheet 6 of 9)

**STANDARD 000001-08**

**RIGHT OF WAY ITEMS**

(contd.)

**EX**

**PR**

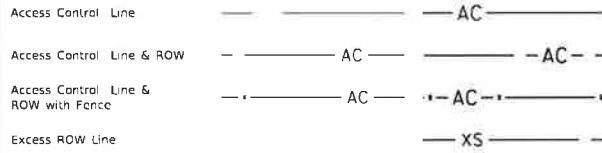

**ROADWAY PLAN ITEMS**

**EX**

**PR**

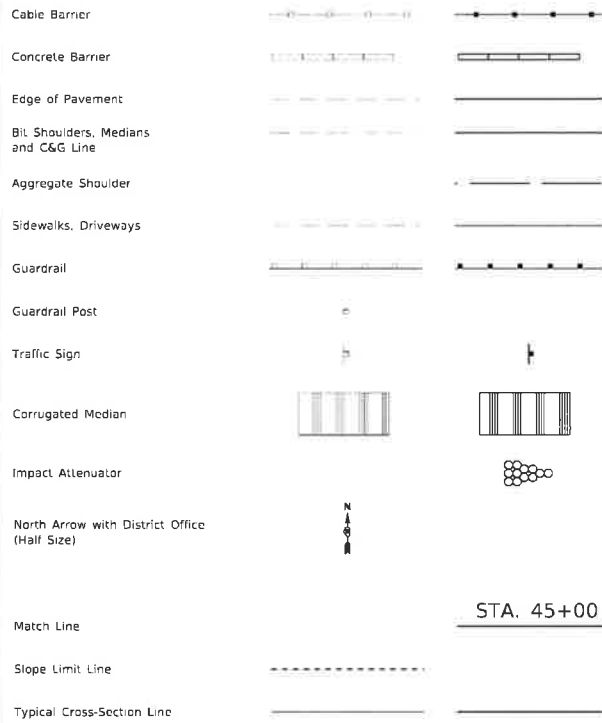

STA. 45+00

Illinois Department of Transportation

DESIGNED BY: [Signature] DATE: [Date]

CHECKED BY: [Signature] DATE: [Date]

APPROVED BY: [Signature] DATE: [Date]

ENGINEER OF DESIGN AND ENVIRONMENT

**ROADWAY PROFILES**

**EX**

**PR**

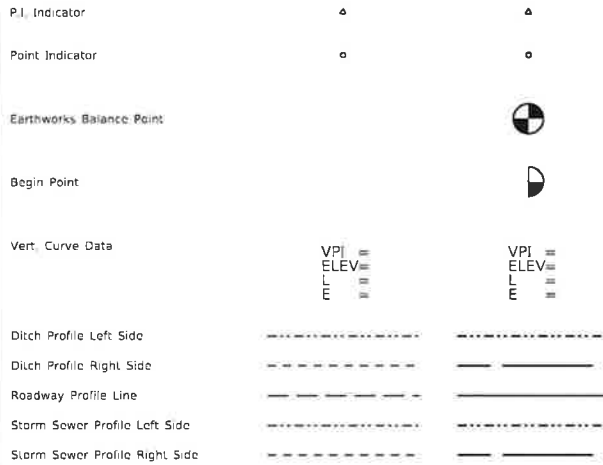

**SIGNING ITEMS**

**EX**

**PR**

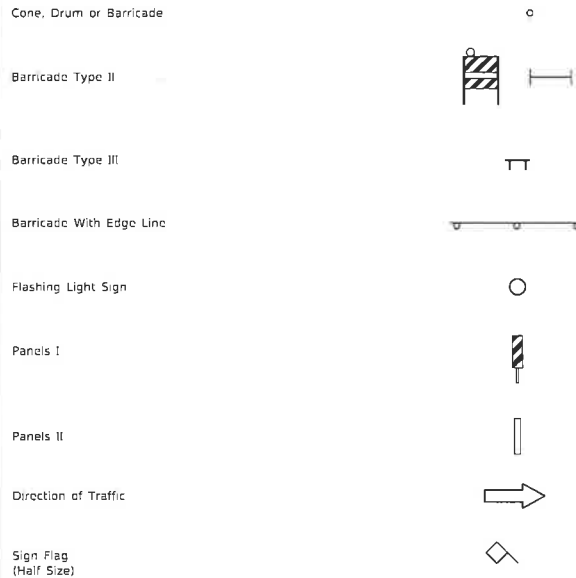

**SIGNING ITEMS**

(contd.)

**EX**

**PR**

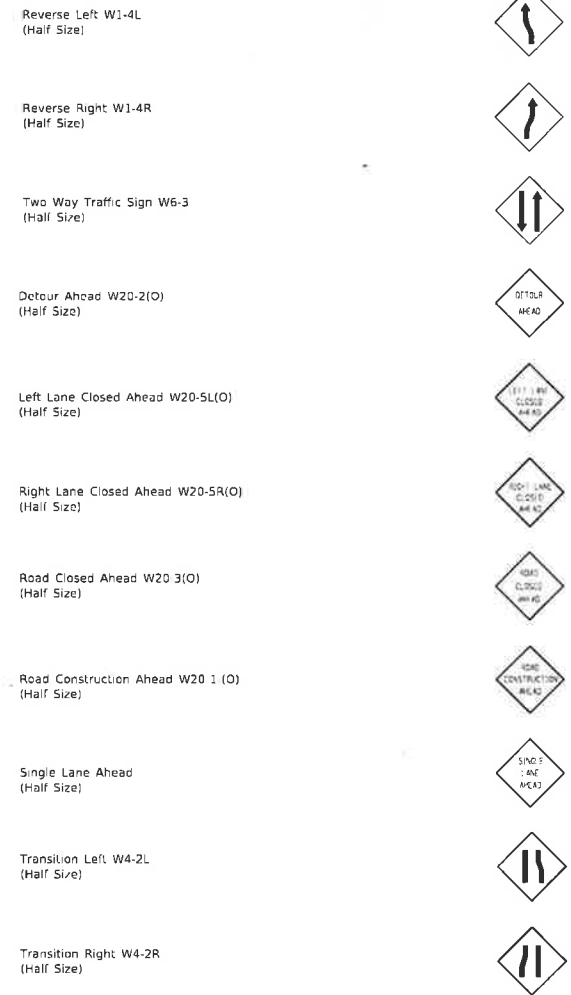

**STANDARD SYMBOLS, ABBREVIATIONS AND PATTERNS**

(Sheet 7 of 9)

STANDARD 000001-08

**SIGNING ITEMS  
(contd.)**

**EX**

**PR**

- One Way Arrow Lrg. W1-6-(O)  
(Half Size)
- Two Way Arrow Large W1-7-(O)  
(Half Size)
- Detour M4 10L (O)  
(Half Size)
- Detour M4-10R-(O)  
(Half Size)
- One Way Left R6-1L  
(Half Size)
- One Way Right R6-1R  
(Half Size)
- Left Turn Lane R3-100L  
(Half Size)
- Keep Left R4-7AL  
(Half Size)
- Keep Left R4-7BL  
(Half Size)
- Keep Right R4-7AR  
(Half Size)
- Keep Right R4-7BR  
(Half Size)
- Stop Here On Red R10-6-AL  
(Half Size)
- Stop Here On Red R10-6-AR  
(Half Size)
- No Left Turn R3-2  
(Half Size)
- No Right Turn R3-1  
(Half Size)
- Road Closed R11-2  
(Half Size)
- Road Closed Thru Traffic R11-2  
(Half Size)



**STRUCTURES ITEMS**

**EX**

**PR**

- Box Culvert Barrel
- Box Culvert Headwall
- Bridge Pier
- Bridge
- Retaining Wall
- Temporary Sheet Piling

**TRAFFIC SHEET  
ITEMS**

**EX**

**PR**

- Cable Number
- Left Turn Green
- Left Turn Yellow
- Signal Backplate
- Signal Section 8" (200 mm)
- Signal Section 12" (300 mm)
- Walk/Don't Walk Letters
- Walk/Don't Walk Symbols



**TRAFFIC SIGNAL  
ITEMS**

**EX**

**PR**

- Galv. Steel Conduit
- Underground Cable
- Detector Loop Line
- Detector Loop Large
- Detector Loop Small
- Detector Loop Quadrupole

**STANDARD SYMBOLS,  
ABBREVIATIONS  
AND PATTERNS**

(Sheet 8 of 9)

**STANDARD 000001-08**

Illinois Department of Transportation

PROJECT: [Signature] January 1, 2011

APPROVED: [Signature] January 1, 2011

ENGINEER OF DESIGN AND ENVIRONMENT

ALERT OFFICE

<b>TRAFFIC SIGNAL ITEMS (contd.)</b>			<b>UNDERGROUND UTILITY ITEMS</b>			<b>UTILITY ITEMS (contd.)</b>			
	<b>EX</b>	<b>PR</b>		<b>EX</b>	<b>PR</b>	<b>ABANDONED</b>		<b>EX</b>	<b>PR</b>
Detector Raceway			Cable TV				Traffic Signal		
Aluminum Mast Arm			Electric Cable				Traffic Signal Control Box		
Steel Mast Arm			Fiber Optic				Water Meter		
Veh. Detector Magnetic			Gas Pipe				Water Meter Valve Box		
Conduit Splice			Oil Pipe				Profile Line		
Controller			Sanitary Sewer				Aerial Power Line		
Gulfbbox Junction			Telephone Cable				<b>VEGETATION ITEMS</b>		
Wood Pole			Water Pipe				Deciduous Tree		
Temp. Signal Head			<b>UTILITIES ITEMS</b>				Bush or Shrub		
Handhole			Controller				Evergreen Tree		
Double Handhole			Double Handhole				Stump		
Heavy Duty Handhole			Fire Hydrant				Orchard/Nursery Line		
Junction Box			GuyWire or Deadman Anchor				Vegetation Line		
Ped. Pushbutton Detector			Handhole				Woods & Bush Line		
Ped. Signal Head			Heavy Duty Handhole				<b>WATER FEATURE ITEMS</b>		
Power Pole Service			Junction Box				Stream or Drainage Ditch		
Priority Veh. Detector			Light Pole				Waters Edge		
Signal Head			Manhole				Water Surface Indicator		
Signal Head w/Backplate			Monitoring Well (Gasoline)				Water Point		
Signal Post			Pipeline Warning Sign				Disappearing Ditch		
Closed Circuit TV			Power Pole				Marsh		
Video Detector System			Power Pole with Light				Marsh/Swamp Boundary		
			Sanitary Sewer Cleanout						
			Splice Box Above Ground						
			Telephone Splice Box Above Ground						
			Telephone Pole						

Illinois Department of Transportation

ISSUED: *[Signature]* FEBRUARY 1, 2021

APPROVED: *[Signature]* FEBRUARY 1, 2021

1611 03/05

**STANDARD SYMBOLS, ABBREVIATIONS AND PATTERNS**  
(Sheet 9 of 9)

**STANDARD 000001-08**

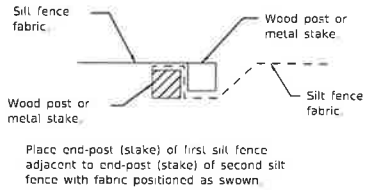

**STEP 1**

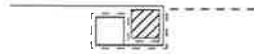

Rotate posts (stakes) together 180° clockwise and drive both posts (stakes) 18 (450) into ground.

**STEP 2**

**ATTACHING TWO SILT FILTER FENCES**  
(Not applicable for J-hooks)

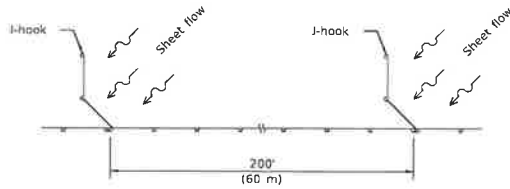

**SILT FILTER J-HOOK PLACEMENT**

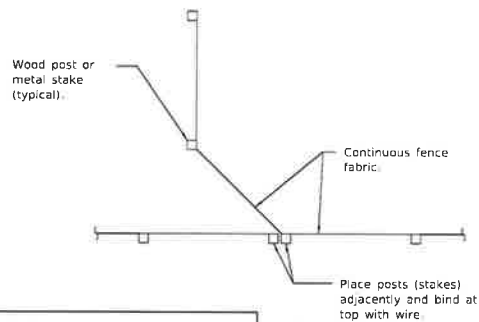

**J-HOOK**

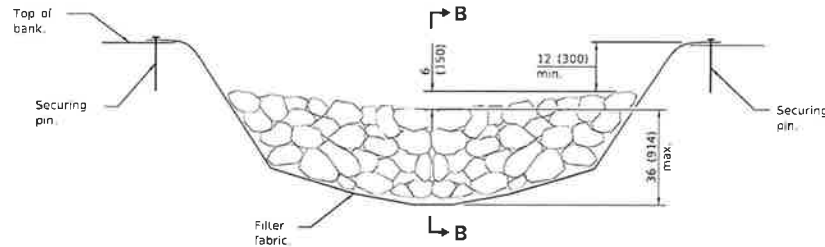

**ELEVATION**

\* When the ditch check is within the clear zone and the road is open to traffic, the traffic approach slope of the aggregate shall be 1:4 (V:H).

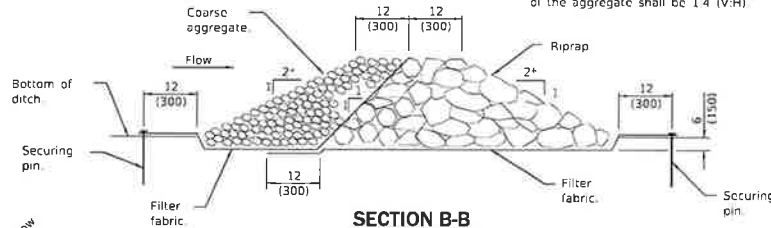

**SECTION B-B**

**AGGREGATE DITCH CHECK**

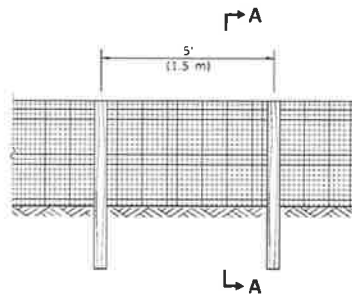

**ELEVATION**

**SILT FILTER FENCE AS A PERIMETER EROSION BARRIER**

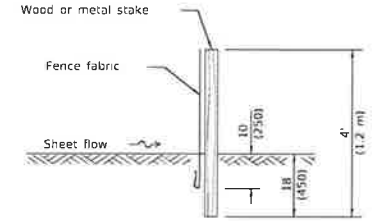

**SLICE METHOD**

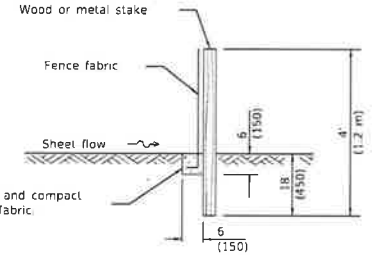

**TRENCH METHOD**

**SECTION A-A**

Excavate, backfill and compact trench to secure fabric.

**GENERAL NOTES**

The installation details and dimensions shown for perimeter erosion barriers shall also apply for inlet and pipe protection.

All dimensions are in inches (millimeters) unless otherwise shown.

DATE	REVISIONS
1-1-13	Corrected notation for flowline (E) on SEDIMENT BASIN ELEVATION.
1-1-12	Omitted hay/straw perimeter barrier. Added SLICE METHOD to SECTION A-A.

**TEMPORARY EROSION CONTROL SYSTEMS**  
(Sheet 1 of 2)

**STANDARD 280001-07**

Illinois Department of Transportation

PASSED January 1, 2013

ENGINEER OF POLICY AND PROCEDURES

APPROVED January 3, 2013

ENGINEER OF DESIGN AND ENVIRONMENT

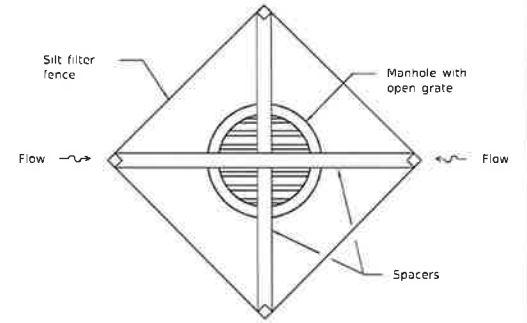
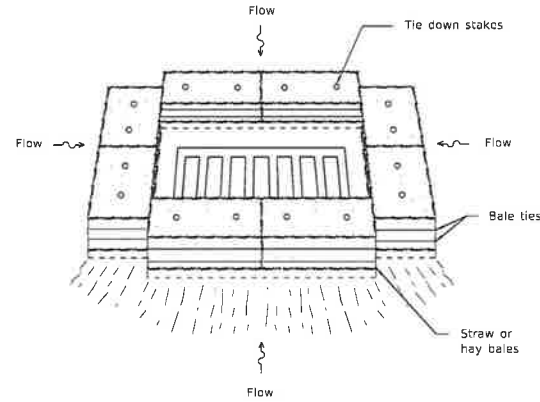
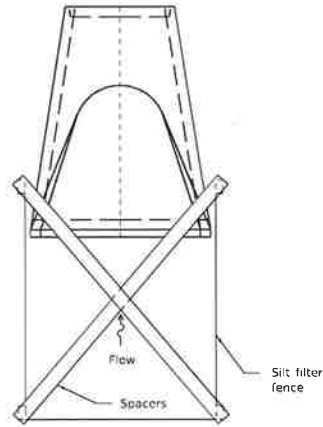
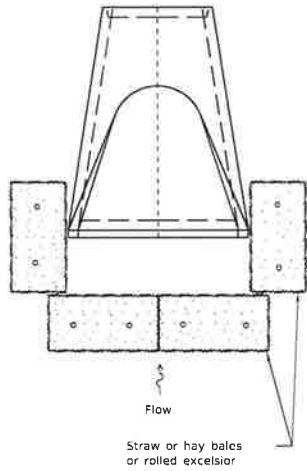

**INLET AND PIPE PROTECTION**

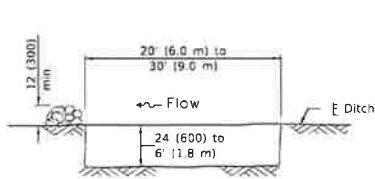

The performance of the basin will improve if put into a series

**ELEVATION**

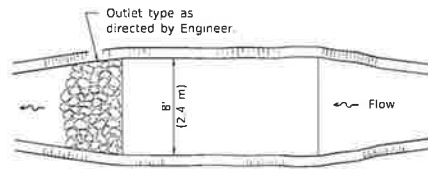

The long dimension should be parallel with the direction of the flow. Accumulated silt shall be removed anytime the basins become 75% filled.

**PLAN**

**SEDIMENT BASIN**

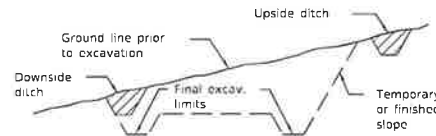

**TYPICAL CUT CROSS-SECTION**

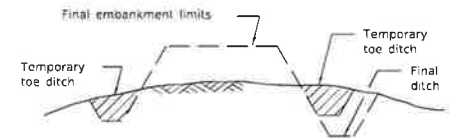

**TYPICAL FILL CROSS-SECTION**

**TEMPORARY DITCHES FOR CUT & FILL SECTIONS**

**TEMPORARY EROSION CONTROL SYSTEMS**

(Sheet 2 of 2)

**STANDARD 280001-07**

Illinois Department of Transportation

PASS/ID January 1, 2013

ENGINEER OF POLICY AND PROCEDURES  
Michael Brand

APPROVED January 1, 2013

ENGINEER OF DESIGN AND INSPECTION

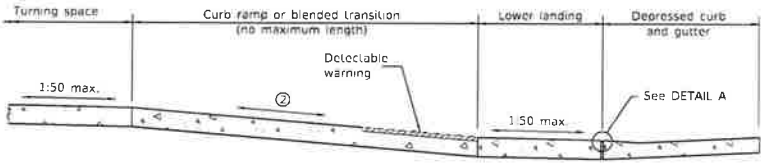
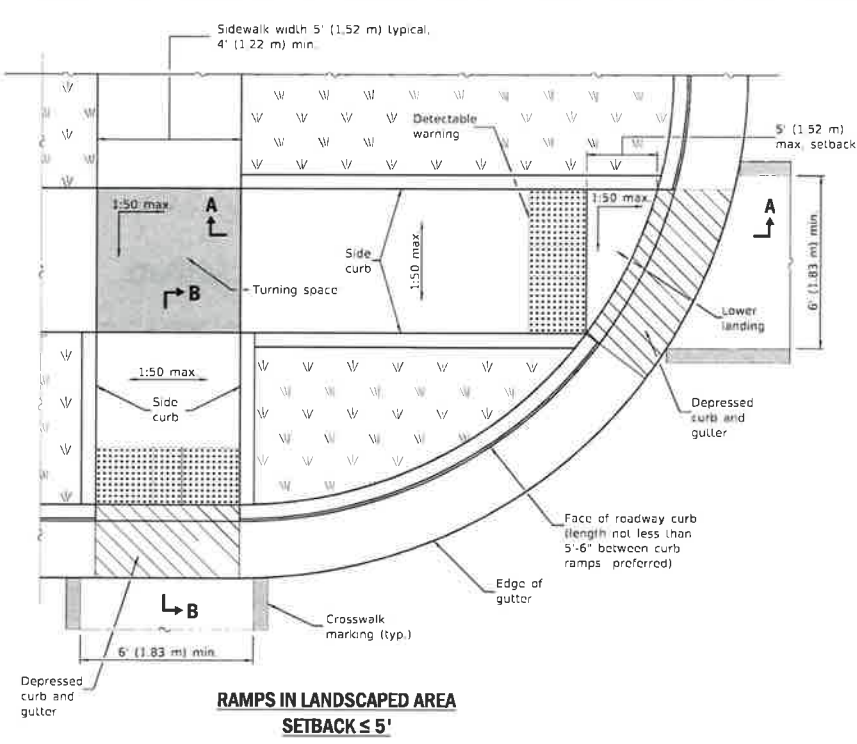

② The running slope of a curb ramp shall be 1:20 min. and 1:12 max. The running slope of a blended transition shall be 1:20 max.

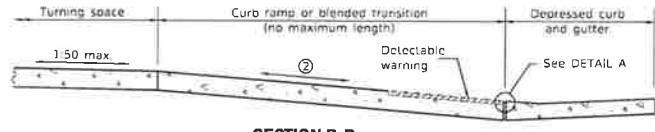
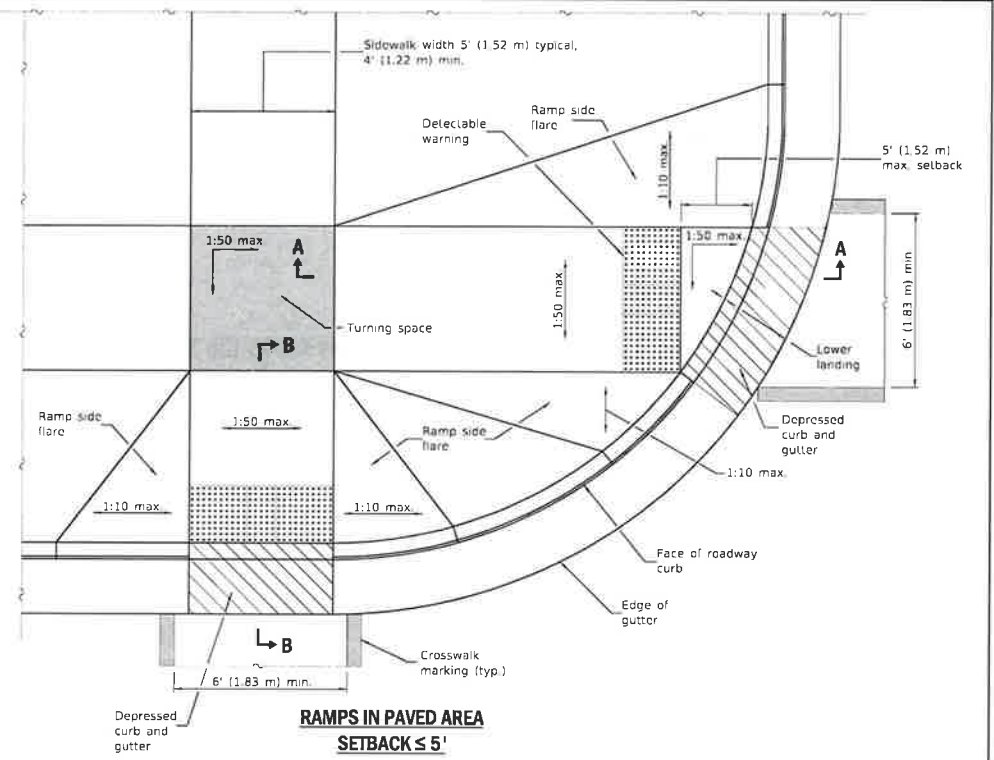

② The running slope of a curb ramp shall be 1:20 min. and 1:12 max. The running slope of a blended transition shall be 1:20 max.

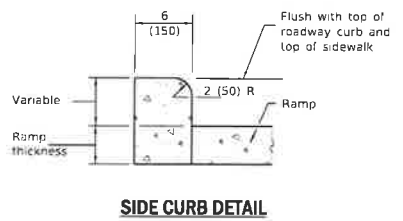
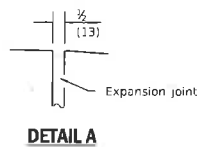

Illinois Department of Transportation

PASSIT January 1, 2019

HIGHWAY DESIGN AND PROCEDURES

APPROVED January 1, 2019

REGISTERED PROFESSIONAL ENGINEER

See Sheet 2 for GENERAL NOTES.

DATE	REVISIONS
1-1-19	Removed "15-foot rule", added "Blended transitions" and placement tolerances for detectable warnings
1-1-18	Omitted diagonal slope at turning spaces and lower landings.

**PERPENDICULAR CURB RAMPS FOR SIDEWALKS**

(Sheet 1 of 2)

**STANDARD 424001-11**

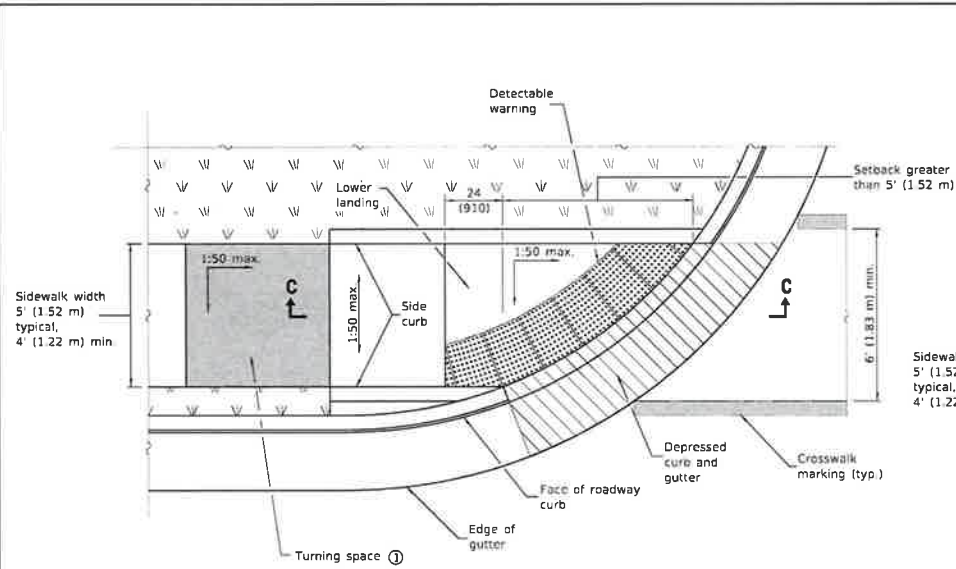

**RAMP IN LANDSCAPED AREA  
SETBACK > 5'**

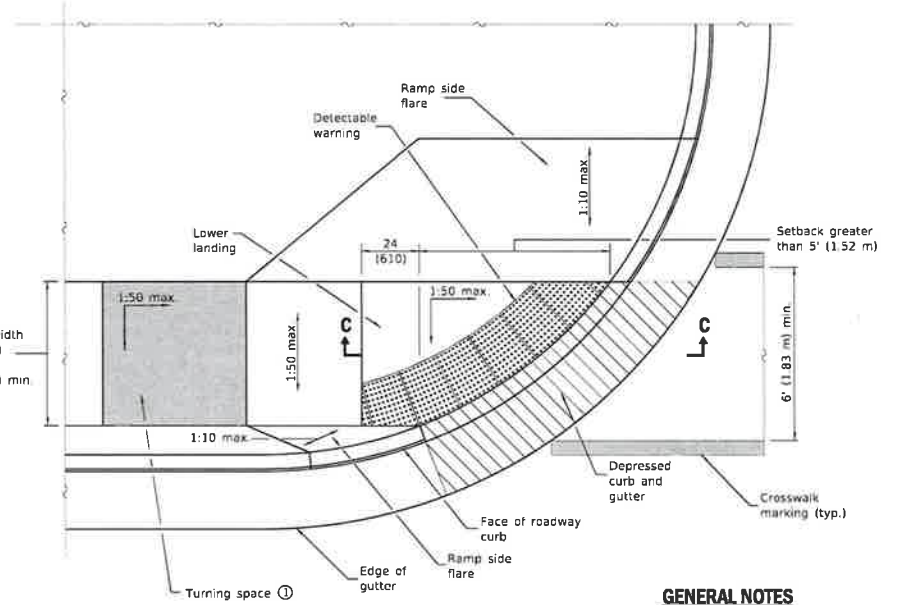

**RAMP IN PAVED AREA  
SETBACK > 5'**

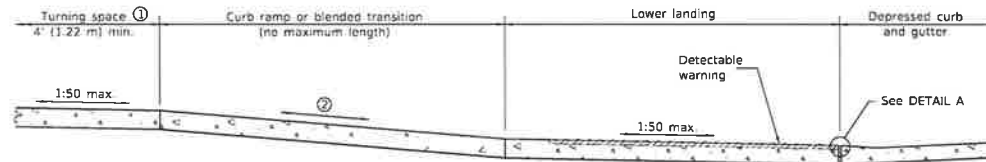

**SECTION C-C**

- ① This turning space not required for blended transitions.
- ② The running slope of a curb ramp shall be 1:20 min. and 1:12 max. The running slope of a blended transition shall be 1:20 max.

**GENERAL NOTES**

All slope ratios are expressed as units of vertical displacement to units of horizontal displacement (V:H).

Where the turning space is constrained on a side opposite a ramp, the minimum length of the turning space in the direction of the ramp-run shall be 5' (1.52 m).

Where 1:50 maximum slope is shown, 1:64 is preferred.

Detectable warnings are shown in their ideal locations but the following placement tolerances are allowed.

**Side Border** - Detectable warnings should extend the full width of the walking surface (excluding flared sides) but a border along each side up to 2 in. (50 mm) in width is allowed.

**Curb Set-Back** - Detectable warnings located at the back of curb should closely align with the curb but a gap up to 6 in. (150 mm) behind the curb is allowed.

See Standard 606001 for details of depressed curb adjacent to curb ramp.

All dimensions are in inches (millimeters) unless otherwise shown.

**PERPENDICULAR CURB RAMPS  
FOR SIDEWALKS**

(Sheet 2 of 2)

**STANDARD 424001-11**

Illinois Department of Transportation

PASSED	January 1, 2019	154870
ENGINEER OF POLICY AND PROCEDURES		
APPROVED	January 1, 2019	154870
ENGINEER OF DESIGN AND TRANSPORTATION		

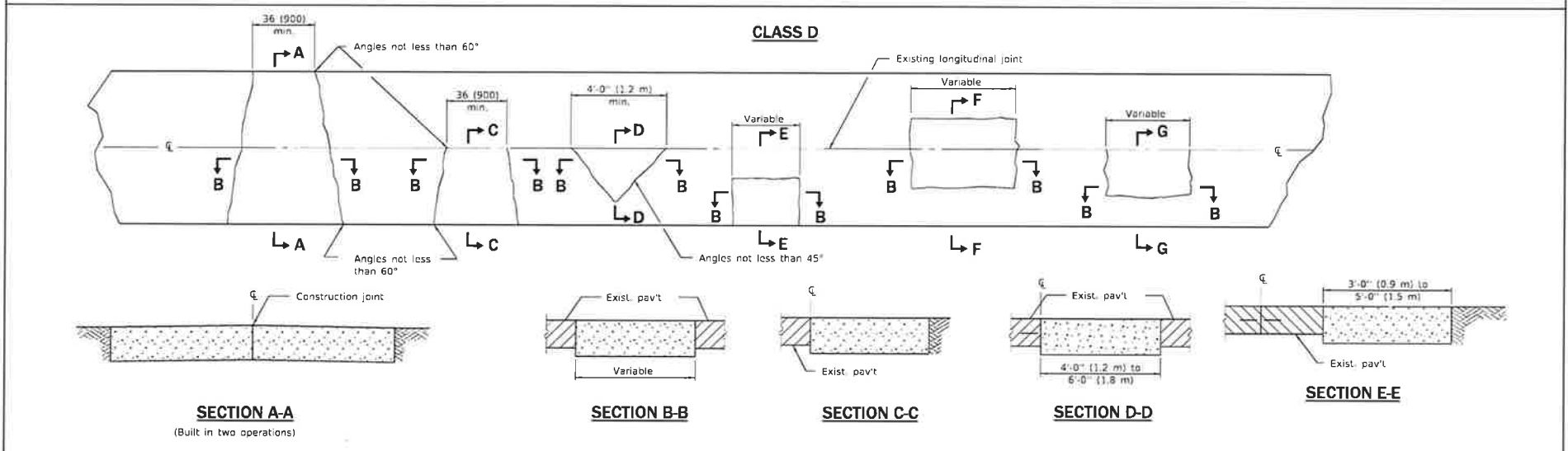
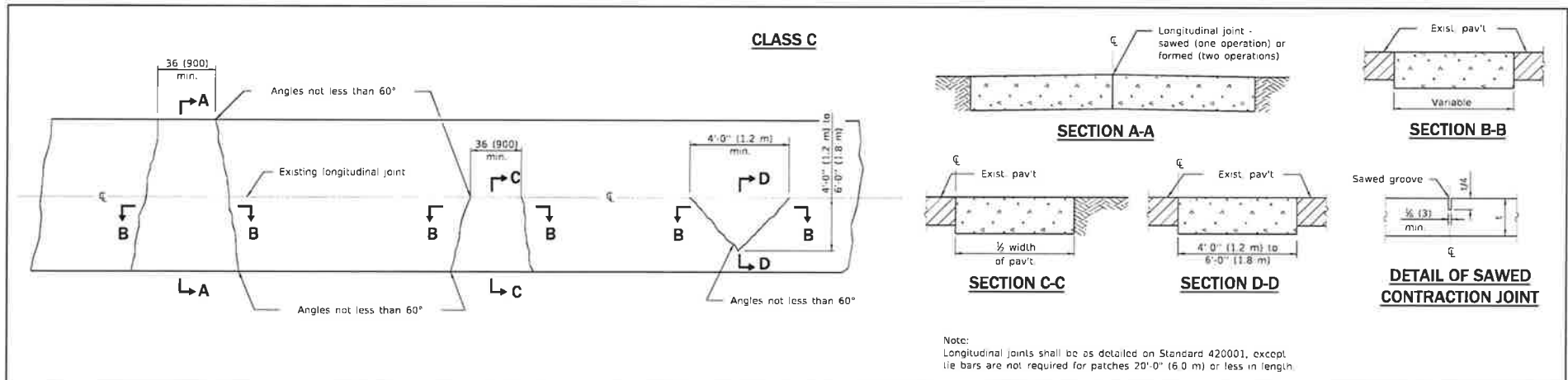

**GENERAL NOTES**  
Existing tie bars shall be either cut or removed. Marginal bars shall be cut.  
All dimensions are in inches (millimeters) unless otherwise shown.

DATE	REVISIONS
1 1 08	Switched units to English (metric)
1-1-07	Revised Note for Class C patches

**CLASS C and D PATCHES**

**STANDARD 442201-03**

Illinois Department of Transportation

PASSED January 1, 2008

MANAGER OF POLICY AND PROCEDURES

APPROVED Henry L. 2008

ENGINEER OF DESIGN AND ENVIRONMENT

METRIC CONIC

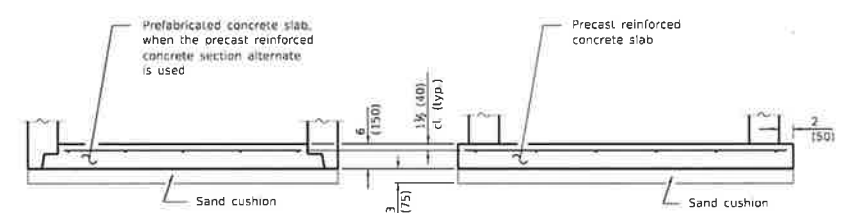
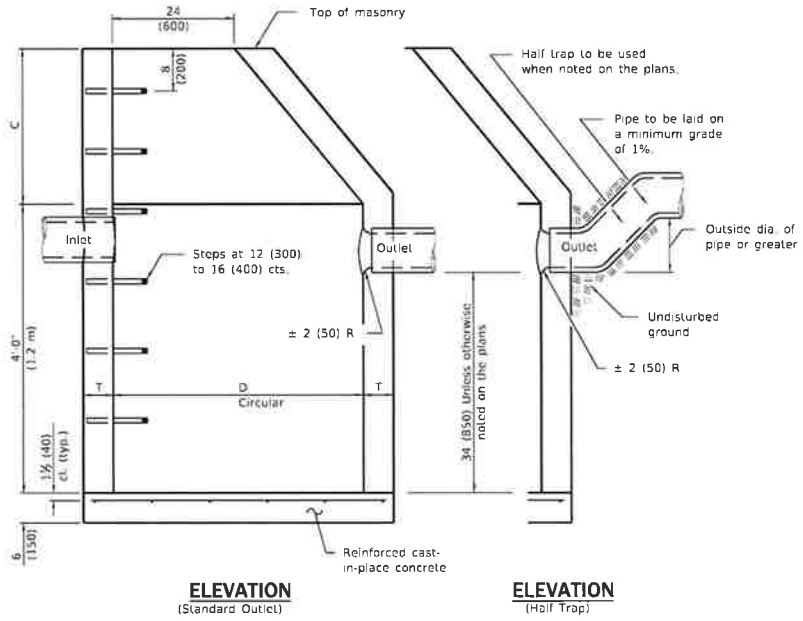

**ALTERNATE BOTTOM SLAB**

ALTERNATE MATERIALS FOR WALLS	D	C	T (min.)
Concrete Masonry Unit	4'-0" (1.2 m)	30 (750)	5 (125)
	5'-0" (1.5 m)	3'-9" (1.15 m)	5 (125)
Brick Masonry	4'-0" (1.2 m)	30 (750)	8 (200)
	5'-0" (1.5 m)	3'-9" (1.15 m)	8 (200)
Precast Reinforced Concrete Section	4'-0" (1.2 m)	30 (750)	4 (100)
	5'-0" (1.5 m)	3'-9" (1.15 m)	5 (125)
Cast-in-place Concrete	4'-0" (1.2 m)	30 (750)	6 (150)
	5'-0" (1.5 m)	3'-9" (1.15 m)	6 (150)

\* For precast reinforced concrete sections, dimension "C" may vary from the dimension given to plus 6 (150).

**GENERAL NOTES**

Bottom slabs shall be reinforced with a minimum of 0.20 sq. in./ft (420 sq. mm/m) in both directions with a maximum spacing of 12 (300).

Bottom slabs may be connected to the riser as determined by the fabricator; however, only a single row of reinforcement around the perimeter may be utilized.

See Standard 602601 for optional precast reinforced concrete flat slab top.

See Standard 602701 for details of steps.

All dimensions are in inches (millimeters) unless otherwise shown.

Illinois Department of Transportation

ISSUED: February 3, 2011

APPROVED: *Michael Brand*

ENGINEER OF POLICY AND PROCEDURES

APPROVED: *[Signature]*

February 3, 2011

ENGINEER OF DESIGN AND ENVIRONMENT

DATE	REVISIONS
1-1-11	Added 'Outside' to half trap note. Detail rein. in slabs.
	Revised general notes.
1-1-09	Switched units to English (metric).

**CATCH BASIN TYPE A**

**STANDARD 602001-02**

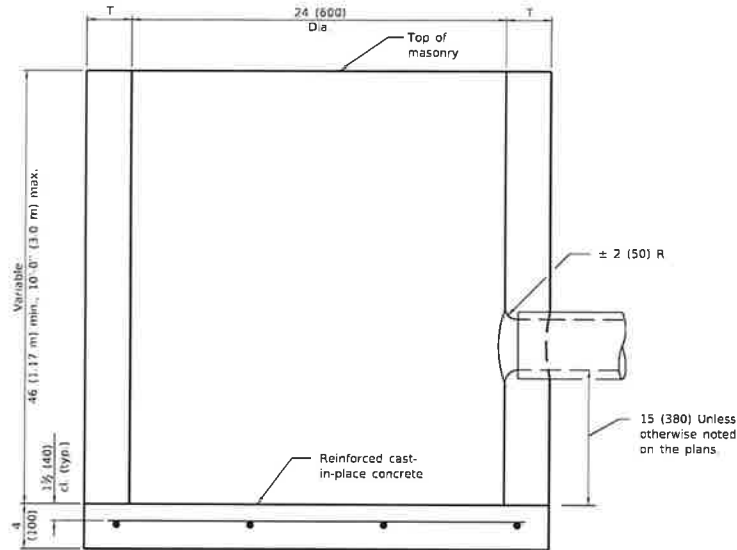

**ELEVATION**

ALTERNATE MATERIALS FOR WALLS	T (min)
Precast Reinforced Concrete Section	3 (75)
Concrete Masonry Unit	5 (125)
Cast-in-Place Concrete	6 (150)
Brick Masonry	8 (200)

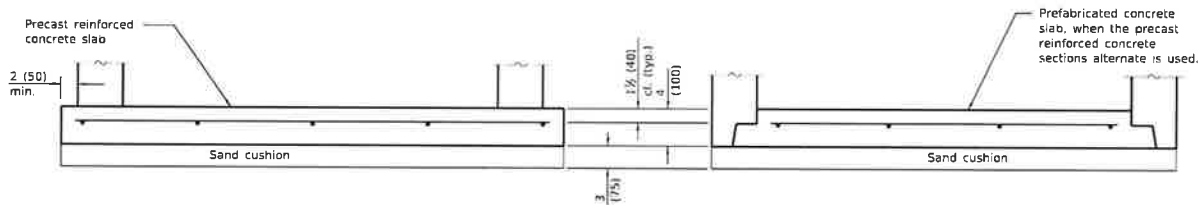

**ALTERNATE BOTTOM SLAB**

**GENERAL NOTES**

Bottom slabs shall be reinforced with a minimum of 0.27 sq. in./ft. (570 sq. mm/m) in both directions with a maximum spacing of 9 (230).

Bottom slabs may be connected to the riser as determined by the fabricator; however, only a single row of reinforcement around the perimeter may be utilized.

All dimensions are in inches (millimeters) unless otherwise shown.

Illinois Department of Transportation

ISSUED: January 1, 2011

ENGINEER: *Michael Beaudin*

APPROVED: *[Signature]* January 1, 2011

ENGINEER OF DESIGN AND PERFORMANCE

DATE: 1/1/2011

DATE	REVISIONS
1-1-11	Detailed rein in slabs
	Added max. limit to height
	Added general notes
1-1-09	Switched units to
	English (metric)

**CATCH BASIN TYPE C**

**STANDARD 602011-02**

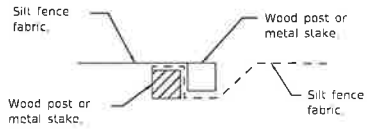

Place end-post (stake) of first silt fence adjacent to end-post (stake) of second silt fence with fabric positioned as shown.

**STEP 1**

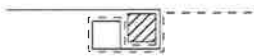

Rotate posts (stakes) together 180° clockwise and drive both posts (stakes) 18 (450) into ground.

**STEP 2**

**ATTACHING TWO SILT FILTER FENCES**  
(Not applicable for J-hooks)

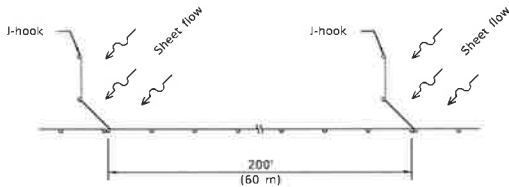

**SILT FILTER J-HOOK PLACEMENT**

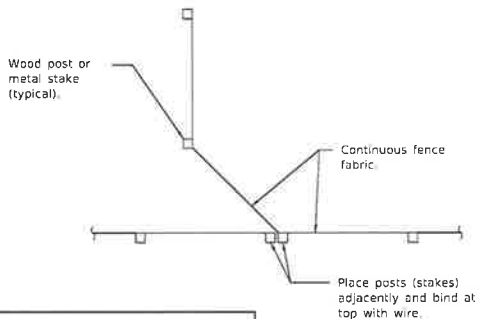

**J-HOOK**

Illinois Department of Transportation

PASS ID: *Michael Beard* January 1, 2013  
ENGINEER OF POLICY AND PROCEDURES

APPROVED: *[Signature]* January 1, 2013  
ENGINEER OF DESIGN AND ENVIRONMENT

6.1.1. 03/05

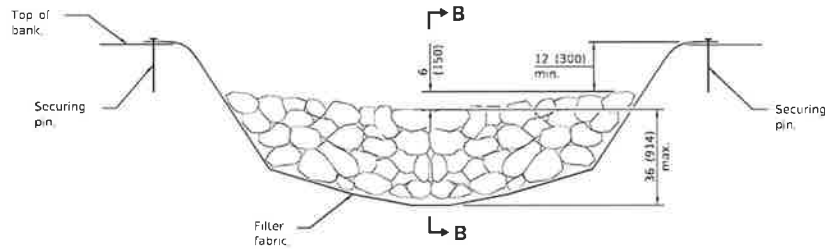

**ELEVATION**

When the ditch check is within the clear zone and the road is open to traffic, the traffic approach slope of the aggregate shall be 1:4 (V:H)

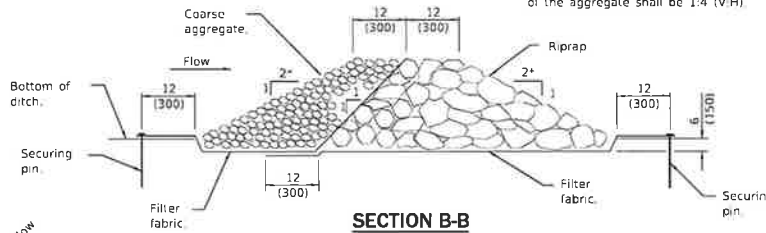

**SECTION B-B**

**AGGREGATE DITCH CHECK**

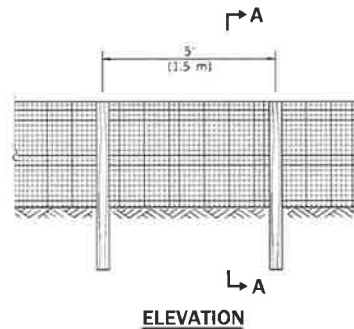

**SILT FILTER FENCE AS A PERIMETER EROSION BARRIER**

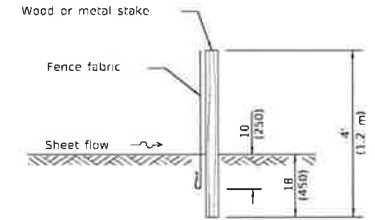

**SLICE METHOD**

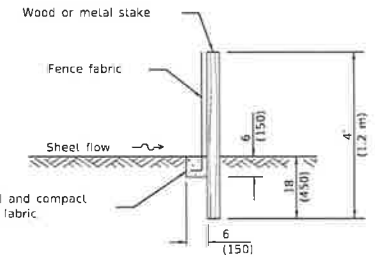

**TRENCH METHOD**

**SECTION A-A**

Excavate, backfill and compact trench to secure fabric.

**GENERAL NOTES**

The installation details and dimensions shown for perimeter erosion barriers shall also apply for inlet and pipe protection.

All dimensions are in inches (millimeters) unless otherwise shown.

DATE	REVISIONS
1-1-13	Corrected notation for flowline (f) on SEDIMENT BASIN ELEVATION.
1-1-12	Omitted hay/straw perimeter barrier. Added SLICE METHOD to SECTION A-A.

**TEMPORARY EROSION CONTROL SYSTEMS**  
(Sheet 1 of 2)

**STANDARD 280001-07**

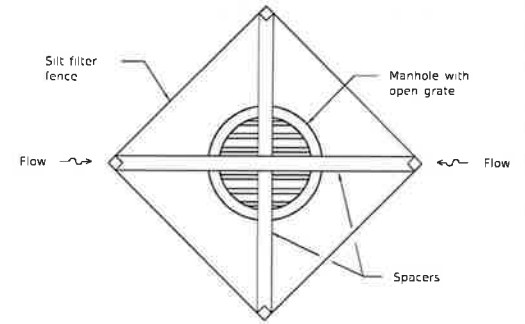
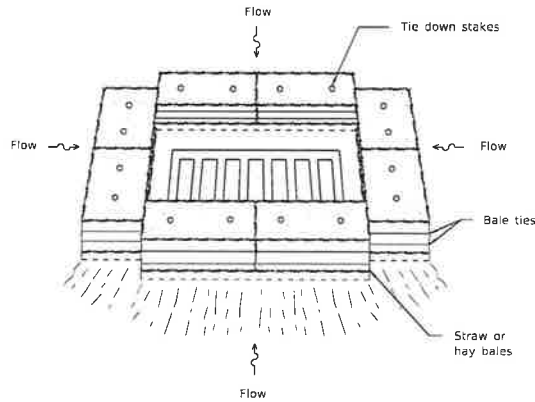
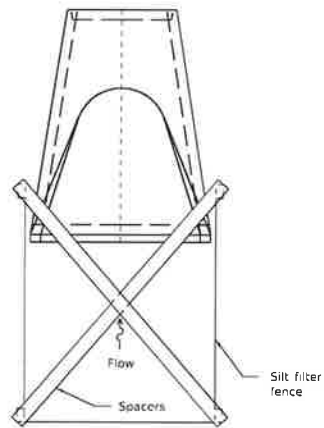
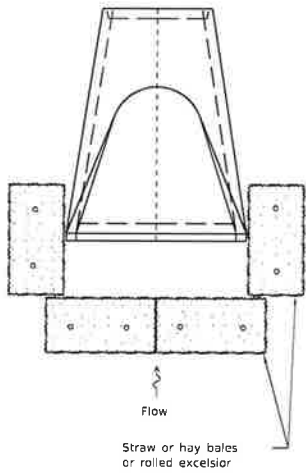

**INLET AND PIPE PROTECTION**

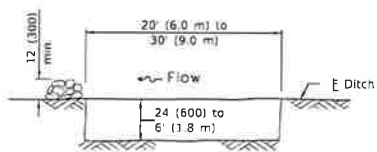

The performance of the basin will improve if put into a series

**ELEVATION**

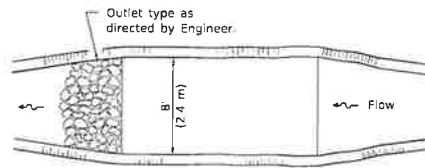

The long dimension should be parallel with the direction of the flow. Accumulated silt shall be removed anytime the basins become 75% filled

**PLAN**

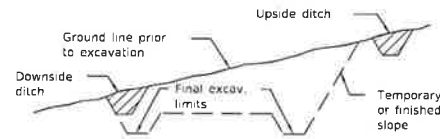

**TYPICAL CUT CROSS-SECTION**

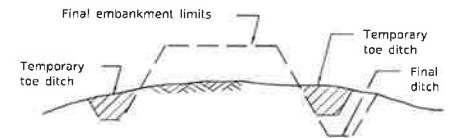

**TYPICAL FILL CROSS-SECTION**

**TEMPORARY DITCHES FOR CUT & FILL SECTIONS**

**SEDIMENT BASIN**

Illinois Department of Transportation	
PASS: D	2013
ENGINEER OF POLICY AND PROCEDURES	2013
ENGINEER OF DESIGN AND ENVIRONMENT	2013

**TEMPORARY EROSION CONTROL SYSTEMS**

(Sheet 2 of 2)

**STANDARD 280001-07**

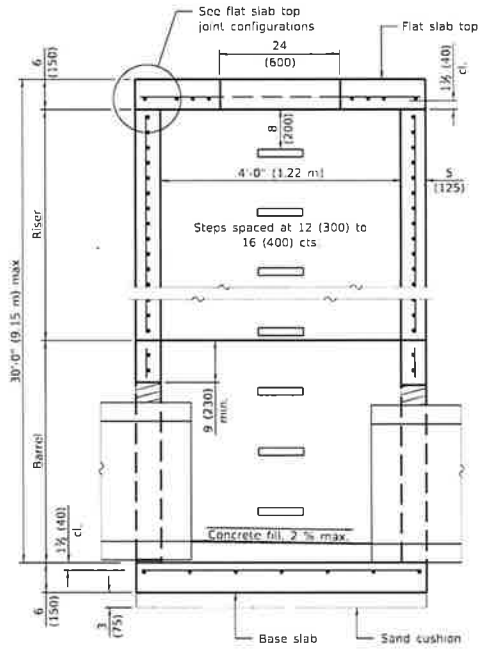

**SECTION PARALLEL TO PIPE**  
(Without conical top riser)

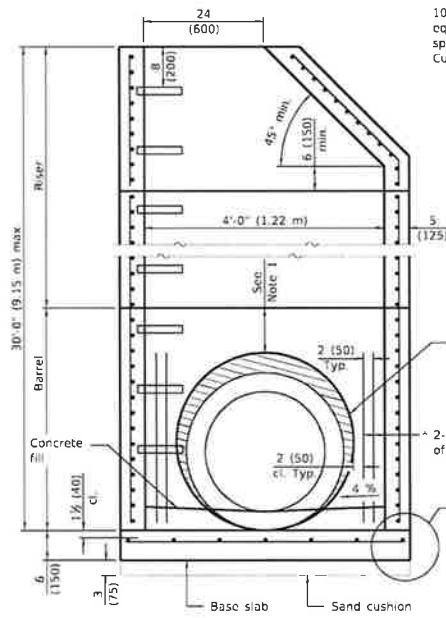

**SECTION PERPENDICULAR TO PIPE**  
(With conical top riser)

\* As an alternate, the barrel wall reinforcement may be reduced to riser wall reinforcement with #3 (#10) bars placed around the pipe penetration holes as shown. This option may be utilized when the pipe penetration holes are formed as opposed to cored.

**GEOMETRIC LIMITS FOR PIPE PENETRATION HOLES**

- Note 1: A minimum of 9 (230) of monolithic reinforced concrete shall be maintained above pipe penetration holes > 24 (600).
- Note 2: A minimum 12 (300) inside arc length of reinforced concrete shall be maintained between pipe penetration holes > 15 (380).
- Note 3: A maximum of 60 percent of the inside perimeter of the reinforced concrete manhole walls may be removed.
- Note 4: Horizontal joints that intersect pipe penetration holes > 15 (380) shall have one joint splice for every location around the perimeter of the joint where the inside arc length between pipe penetration holes is < 24 (600). See joint splice detail.
- Note 5: The recommended pipe penetration hole is equal to the O.D. of the pipe plus 4 (100).
- Note 6: Only pipe penetration holes ≤ 15 (380) are allowed in riser sections.

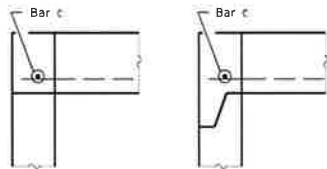

**FLAT SLAB TOP JOINT CONFIGURATIONS**  
(Shown at access hole)

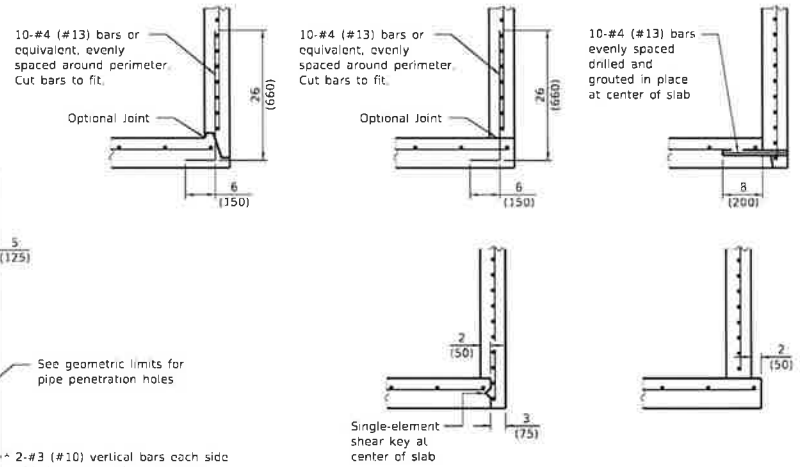

**BASE SLAB JOINT CONFIGURATIONS**

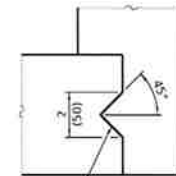

Single-element shear key at center of slab

**SHEAR KEY GEOMETRY**  
(Reinforcement not shown for clarity)

**GENERAL NOTES**

- The manufacturer shall ensure that all precast manhole sections are additionally reinforced where required to resist damage from handling, shipping and installation stresses.
- Lifting holes shall be located in the sections as per the manufacturer's recommendations.
- See Standard 602701 for details of manhole steps.
- All dimensions are in inches (millimeters) unless otherwise noted.

DATE	REVISIONS
1-1-21	Revised Note 1 and lifting hole general note
3-1-19	Moved wall reinforcement from inside face to middle.

**PRECAST MANHOLE TYPE A**  
**4' (1.22 m) DIAMETER**

(Sheet 1 of 2)

**STANDARD 602401-07**

Illinois Department of Transportation

PASSED January 1, 2021 2021

ENGINEER OF POLICY AND PROCEDURES

APPROVED January 1, 2021 2021

ILLINOIS DEPARTMENT OF TRANSPORTATION

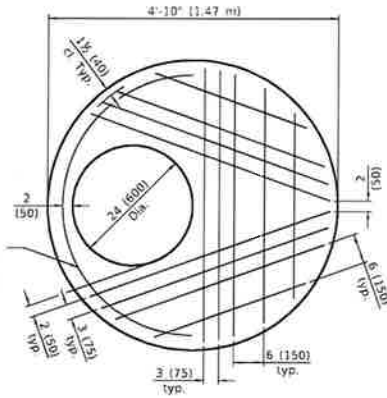

Bar c #5 (#16), 6'-10" (2.08 m) length, 26 (660) radius bottom

**PLAN - FLAT SLAB TOP**

(Showing layout of reinforcement bars and c bars)

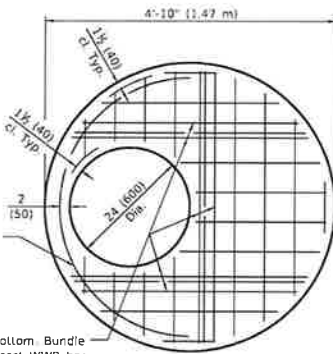

Bar c #5 (#16), 6'-10" (2.08 m) length, 26 (660) radius bottom

#5 (#16) bars bottom. Bundle first bar with closest WWR bar to the opening and place second bar ±3 (75) away.

**PLAN - FLAT SLAB TOP**

(Showing layout of welded wire reinforcement and c bars)

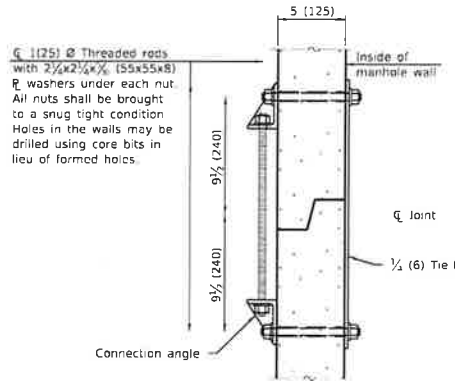

1/2 (125) Ø Threaded rods with 2 1/2 x 2 1/2 x 1/2 (55x55x8) R washers under each nut. All nuts shall be brought to a snug tight condition. Holes in the walls may be drilled using core bits in lieu of formed holes.

**JOINT SPLICE**

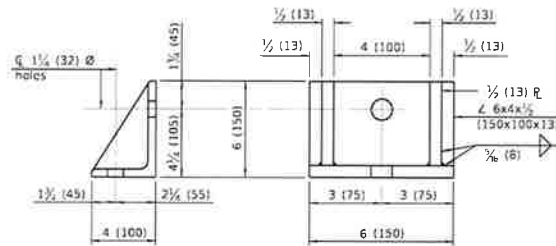

**CONNECTION ANGLE**

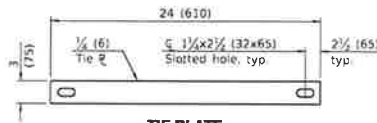

**TIE PLATE**

**FLAT SLAB TOP REINFORCEMENT**

Location	WWR (each direction)		Rebar		Bar Size
	A <sub>s</sub> (min.)	Spacing (max.)	A <sub>s</sub> (min.)	Spacing (max.)	
Bottom Mat	** 0.62 sq. in./ft. (1312 sq. mm/m)	6 (150)	See plan view for rebar orientation and soacing and this table for bar size		#5 (#16)

\*\* Only one layer of WWR permitted to avoid congestion

**WALL REINFORCEMENT**

Location	Orientation	WWR or Rebar	
		A <sub>s</sub> (min.)	Spacing (max.)
Riser	Circumferential	0.12 sq. in./ft. (254 sq. mm/m)	6 (150)
	Vertical	0.045 sq. in./ft. (95 sq. mm/m)	8 (200)
Barrel	Circumferential	0.12 sq. in./ft. (254 sq. mm/m)	6 (150)
	Vertical	0.16 sq. in./ft. (339 sq. mm/m)	4 (100)

**BASE SLAB REINFORCEMENT**

Location	Total Height	WWR or Rebar (each direction)	
		A <sub>s</sub> (min.)	Spacing (max.)
Top Mat	≤ 20 ft. (6.10 m)	0.24 sq. in./ft. (508 sq. mm/m)	10 (250)
	> 20 ft. (6.10 m)	0.24 sq. in./ft. (508 sq. mm/m)	10 (250)

Illinois Department of Transportation

PASSE ID: 10771

ENGINEER OF POLICY AND PROCEDURES

APPROVED: January 1, 2021

ENGINEER OF DESIGN AND PROCUREMENT

**PRECAST MANHOLE TYPE A  
4' (1.22 m) DIAMETER**

(Sheet 2 of 2)

**STANDARD 602401-07**

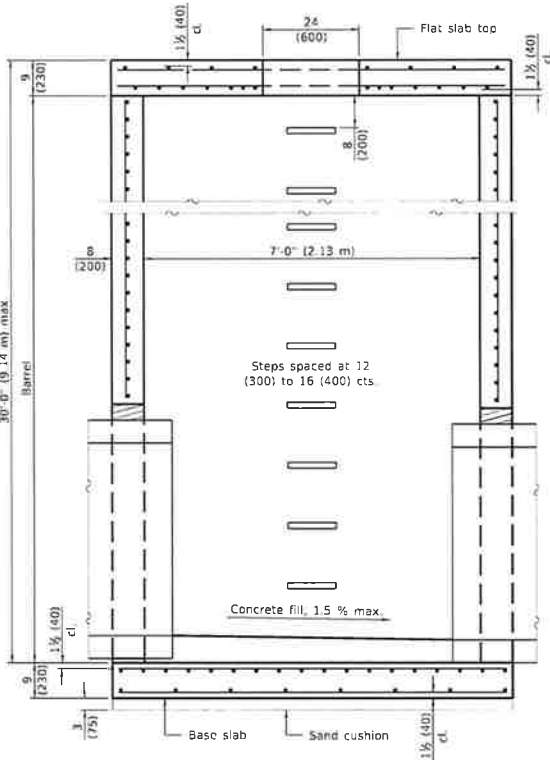

**SECTION PARALLEL TO PIPE**  
(Without conical top riser)

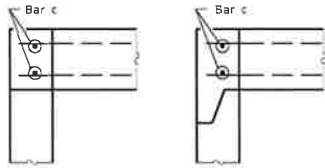

**FLAT SLAB TOP JOINT CONFIGURATIONS**  
(Shown at access hole)

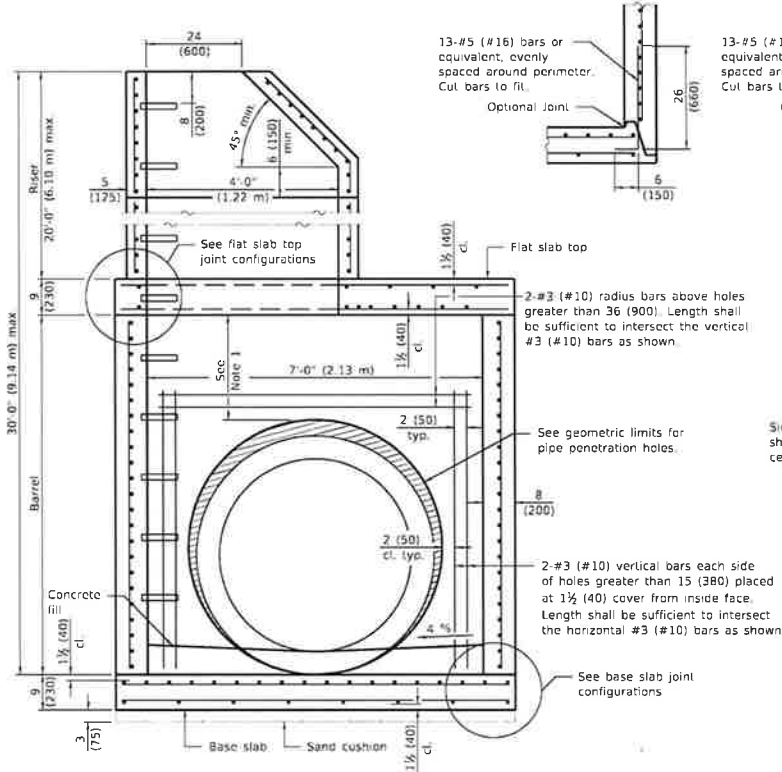

**SECTION PERPENDICULAR TO PIPE**  
(With conical top riser)

**GEOMETRIC LIMITS FOR PIPE PENETRATION HOLES**

- Note 1: A minimum of 12 (300) of monolithic reinforced concrete shall be maintained above pipe penetration holes > 36 (900).
- Note 2: A minimum 12 (300) inside arc length of reinforced concrete shall be maintained between pipe penetration holes > 15 (380).
- Note 3: A maximum of 60 percent of the inside perimeter of the reinforced concrete manhole walls may be removed.
- Note 4: Horizontal joints that intersect pipe penetration holes > 15 (380) shall have one joint splice for every location around the perimeter of the joint where the inside arc length between pipe penetration holes is < 24 (600). See joint splice detail.
- Note 5: The recommended pipe penetration hole is equal to the O.D. of the pipe plus 4 (100).
- Note 6: Only pipe penetration holes ≤ 15 (380) are allowed in riser sections.

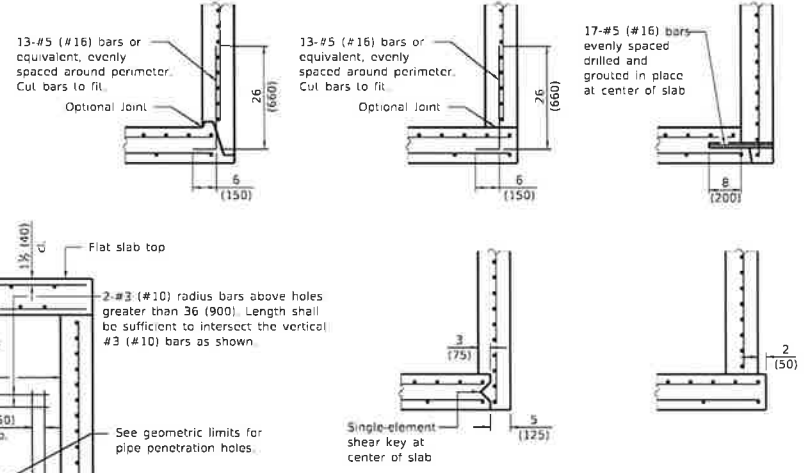

**BASE SLAB JOINT CONFIGURATIONS**

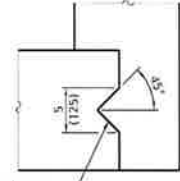

**SHEAR KEY GEOMETRY**  
(Reinforcement not shown for clarity)

**GENERAL NOTES**

- Pipe holes shall be formed to facilitate proper placement of hole reinforcement.
- The manufacturer shall ensure that all precast manhole sections are additionally reinforced where required to resist damage from handling, shipping and installation stresses.
- Lifting holes shall be located in the sections as per the manufacturer's recommendations.
- See Standard 602701 for details of manhole steps.
- All dimensions are in inches (millimeters) unless otherwise noted.

Illinois Department of Transportation

PASSE 01 205 874 1 3221

ENGINEER OF POLICY AND PROCEDURES

APPROVED: [Signature] 2021

NO. 13 - 000005

DATE	REVISIONS
1-1-21	Revised Note 1 and lifting hole general note.
3-1-19	Moved wall reinforcement from inside face to middle.

**PRECAST MANHOLE TYPE A**  
**7' (2.13 m) DIAMETER**  
(Sheet 1 of 3)

**STANDARD 602411-09**

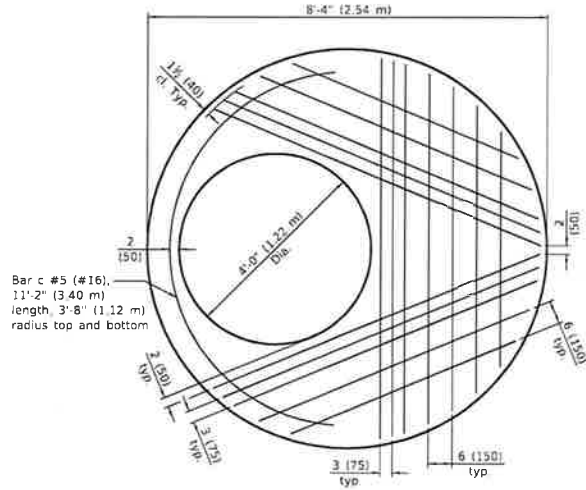

Bar c #5 (#16),  
8'-2" (2.49 m)  
length, 3'-8" (1.12 m)  
radius top and bottom

**PLAN - FLAT SLAB TOP**

(Showing layout of bottom reinforcement bars and c bars)

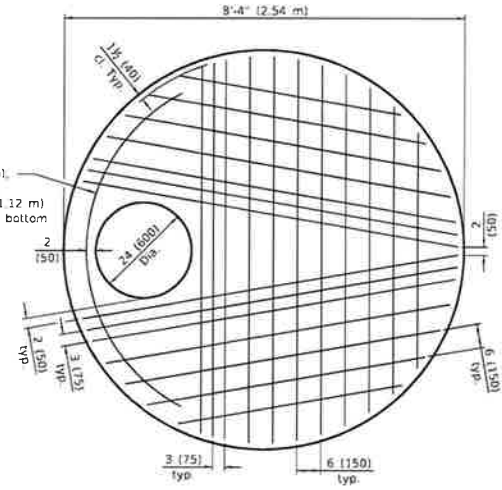

Bar c #5 (#16),  
8'-2" (2.49 m)  
length, 3'-8" (1.12 m)  
radius top and bottom

**PLAN - FLAT SLAB TOP**

(Showing layout of Welded Wire Reinforcement and c bars)  
WWR not permitted for riser heights > 10' (3.05 m).

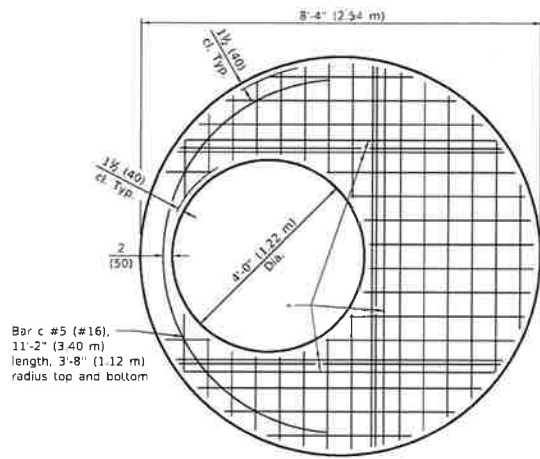

Bar c #5 (#16),  
11'-2" (3.40 m)  
length, 3'-8" (1.12 m)  
radius top and bottom

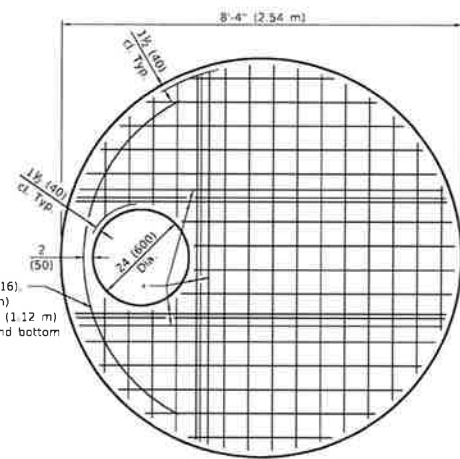

\* #5 (#16) bars bottom: Bundle first bar with closest WWR bar to the opening and place second bar ±3 (75) away

Illinois Department of Transportation

PASS: 11      2021

ENGINEER OF POLICY AND PROCEEDINGS

APPROVED:      2021

ENGINEER OF DESIGN AND TRANSPORTATION

**PRECAST MANHOLE TYPE A**  
**7' (2.13 m) DIAMETER**  
(Sheet 2 of 3)

**STANDARD 602411-09**

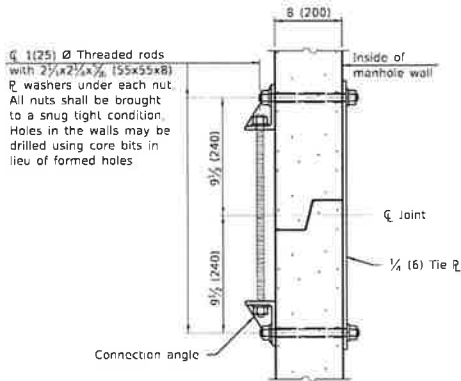

**JOINT SPLICE**

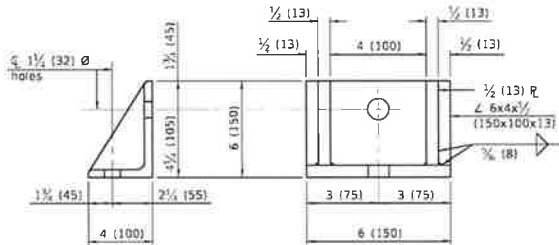

**CONNECTION ANGLE**

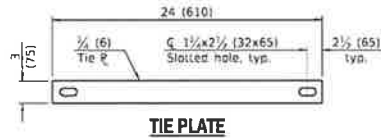

**TIE PLATE**

Use 1 (25)  $\varnothing$  Threaded rods with 2 1/2 x 2 1/2 x 1/4 (32x32x6) R washers under each nut. All nuts shall be brought to a snug tight condition. Holes in the walls may be drilled using core bits in lieu of formed holes

**FLAT SLAB TOP REINFORCEMENT**

Location	Riser Height (RH)	WWR (each direction)		Rebar (each direction except as noted)		
		A <sub>s</sub> (min.)	Spacing (max.)	A <sub>s</sub> (min.)	Spacing (max.)	Bar Size
Top Mat	All	0.11 sq. in./ft. (233 sq. mm/m)	18 (450)	0.11 sq. in./ft. (233 sq. mm/m)	18 (450)	#3 or #4 (#10) (#13)
Bottom Mat	RH ≤ 10 ft. (3.05 m)	** 0.62 sq. in./ft. (312 sq. mm/m)	6 (150)	See plan view for rebar orientation and spacing and this table for bar size		
	RH > 10 ft. (3.05 m)	WWR not permitted				

\*\* Only one layer of WWR permitted to avoid congestion

**WALL REINFORCEMENT**

Location	Orientation	WWR or Rebar	
		A <sub>s</sub> (min.)	Spacing (max.)
4 ft. (1.22 m) $\varnothing$ Riser	Circumferential	0.12 sq. in./ft. (254 sq. mm/m)	6 (150)
	Vertical	0.045 sq. in./ft. (95 sq. mm/m)	8 (200)
7 ft. (2.13 m) $\varnothing$ Barrel	Circumferential	0.21 sq. in./ft. (445 sq. mm/m)	6 (150)
	Vertical	0.045 sq. in./ft. (95 sq. mm/m)	8 (200)

**BASE SLAB REINFORCEMENT**

Location	Riser Height (RH)/ Total Height (TH)	WWR or Rebar (each direction)	
		A <sub>s</sub> (min.)	Spacing (max.)
Top Mat	RH ≤ 10 ft. (3.05 m) & TH ≤ 20 ft. (6.10 m)	0.32 sq. in./ft. (677 sq. mm/m)	6 (150)
	RH > 10 ft. (3.05 m) or TH > 20 ft. (6.10 m)	0.52 sq. in./ft. (1101 sq. mm/m)	6 (150)
Bottom Mat	All	0.11 sq. in./ft. (233 sq. mm/m)	18 (450)

Illinois Department of Transportation  
 PASSED BY: [Signature] 2021  
 ENGINEER OF POLICY AND PROCEDURES  
 APPROVED: [Signature] 2021  
 ENGINEER OF DESIGN AND ESTIMATION

**PRECAST MANHOLE TYPE A**  
**7' (2.13 m) DIAMETER**  
 (Sheet 3 of 3)  
**STANDARD 602411-09**

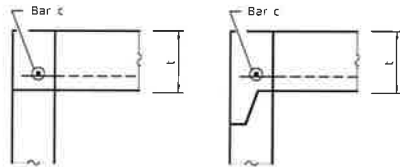

**FLAT SLAB TOP JOINT CONFIGURATIONS  
FOR D = 36 (900) AND D = 4'-0" (1.22 m)**

(Shown at access hole)

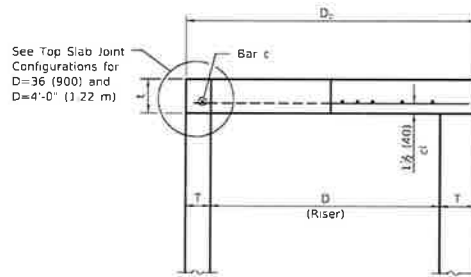

**SECTION THRU FLAT SLAB TOP  
FOR D = 36 (900) AND D = 4'-0" (1.22 m)**

See Top Slab Joint Configurations for D=5'-0" (1.52 m)

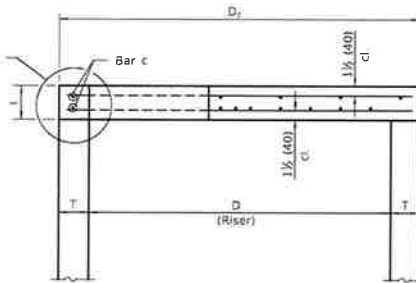

**SECTION THRU FLAT SLAB TOP  
FOR D = 5'-0" (1.52 m)**

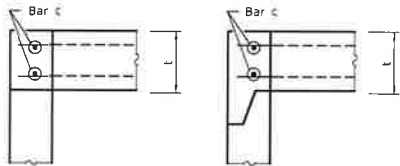

**FLAT SLAB TOP JOINT CONFIGURATIONS  
D = 5'-0" (1.52 m)**

(Shown at access hole)

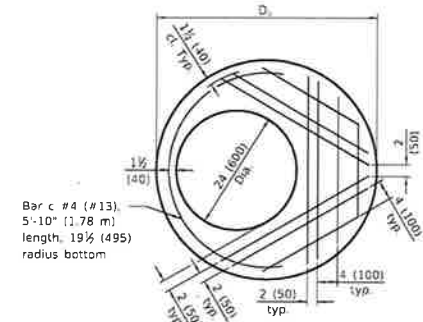

**PLAN - FLAT SLAB TOP FOR D = 36 (900)**  
(Showing layout of reinforcement bars and c bars)

Bar c #4 (#13),  
5'-10" (1.78 m)  
length, 19 1/2 (495)  
radius bottom

#4 (#13) bars bottom. Bundle with closest WWR bar to the opening.

**PLAN - FLAT SLAB TOP FOR D = 36 (900)**  
(Showing layout of welded wire reinforcement and c bars)

**TABLE**

D	T	D <sub>o</sub> (min.)	t
36 (900)			6 (150)
4'-0" (1.2 m)	See applicable Standards	D + 2T	6 (150)
5'-0" (1.5 m)			8 (200)

Illinois Department of Transportation

PROJECT: *ALRD* 2018

ENGINEER OF PROJECT AND PROPOSER:

APPROVER: *[Signature]* 2018

ENGINEER OF DESIGN AND MANAGEMENT:

DATE: 08/11/2018

**GENERAL NOTES**

The flat slab top may be used in lieu of the tapered tops shown on Standards 602001, 602016, or 602306 at the option of the Contractor or when field conditions prohibit the use of tapered tops.

Lifting holes shall be located in the sections as per the manufacturer's recommendations.

All dimensions are in inches (millimeters) unless otherwise shown.

DATE	REVISIONS
1-1-19	Expanded / refined reinforcement options
1-1-18	Revised for compliance with LRFD.

**PRECAST REINFORCED  
CONCRETE FLAT SLAB TOP**

(Sheet 1 of 2)

**STANDARD 602601-06**

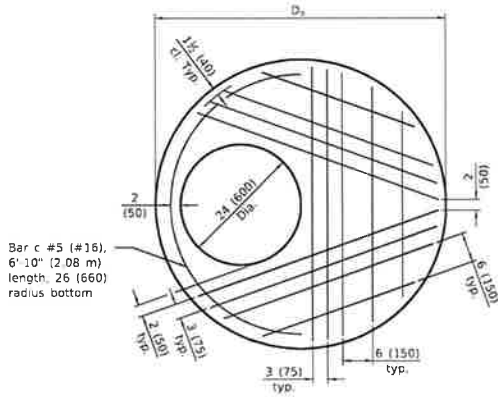

Bar c #5 (#16),  
6'-10" (2.08 m)  
length, 26 (660)  
radius bottom

**PLAN - FLAT SLAB TOP FOR D = 4'-0" (1.22 m)**  
(Showing layout of reinforcement bars and c bars)

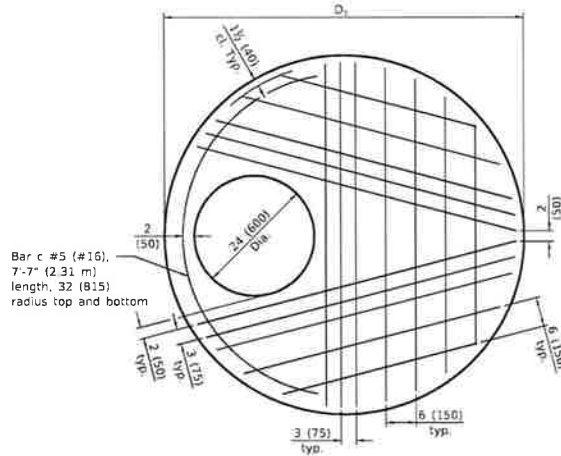

Bar c #5 (#16),  
7'-7" (2.31 m)  
length, 32 (815)  
radius top and bottom

**PLAN - FLAT SLAB TOP FOR D = 5'-0" (1.52 m)**  
(Showing layout of bottom reinforcement bars and c bars)

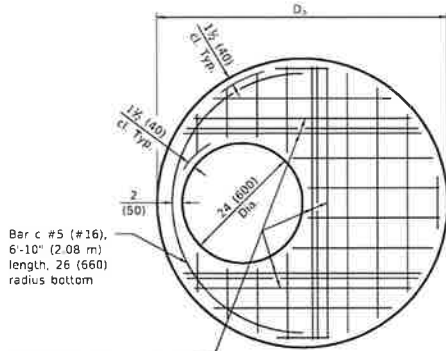

Bar c #5 (#16),  
6'-10" (2.08 m)  
length, 26 (660)  
radius bottom

#5 (#16) bars bottom. Bundle first bar with closest WWR bar to the opening and place second bar ±3 (75) away.

**PLAN - FLAT SLAB TOP FOR D = 4'-0" (1.22 m)**  
(Showing layout of welded wire reinforcement and c bars)

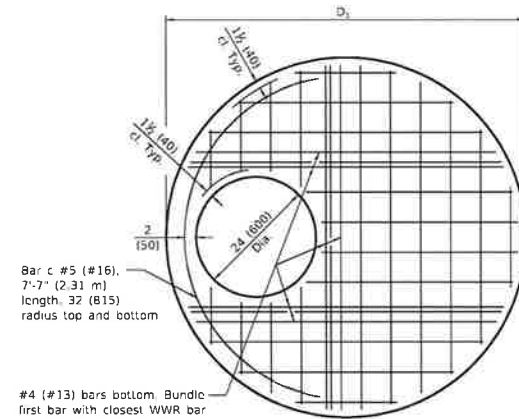

Bar c #5 (#16),  
7'-7" (2.31 m)  
length, 32 (815)  
radius top and bottom

#4 (#13) bars bottom. Bundle first bar with closest WWR bar to the opening and place second bar ±3 (75) away.

**PLAN - FLAT SLAB TOP FOR D = 5'-0" (1.52 m)**  
(Showing layout of welded wire reinforcement and c bars)

**FLAT SLAB TOP REINFORCEMENT FOR D = 36 (900)**

Location	WWR (each direction)		Rebar		Bar Size
	A <sub>s</sub> (min.)	Spacing (max.)	A <sub>s</sub> (min.)	Spacing (max.)	
Bottom Mat	* 0.60 sq in./ft (1270 sq. mm/m)	6 (150)	See plan view for rebar orientation and spacing and this table for bar size		#4 (#13)

**FLAT SLAB TOP REINFORCEMENT FOR D = 4'-0" (1.22 m)**

Location	WWR (each direction)		Rebar		Bar Size
	A <sub>s</sub> (min.)	Spacing (max.)	A <sub>s</sub> (min.)	Spacing (max.)	
Bottom Mat	* 0.62 sq in./ft (1312 sq. mm/m)	6 (150)	See plan view for rebar orientation and spacing and this table for bar size		#5 (#16)

**FLAT SLAB TOP REINFORCEMENT FOR D = 5'-0" (1.52 m)**

Location	WWR (each direction)		Rebar (each direction except as noted)		Bar Size
	A <sub>s</sub> (min.)	Spacing (max.)	A <sub>s</sub> (min.)	Spacing (max.)	
Top Mat	0.11 sq in./ft (233 sq. mm/m)	18 (450)	0.11 sq in./ft (233 sq. mm/m)	18 (450)	#3 or #4 (#10) (#13)
Bottom Mat	* 0.40 sq in./ft (847 sq. mm/m)	6 (150)	See plan view for rebar orientation and spacing and this table for bar size		#4 (#13)

\* Only one layer of WWR permitted to avoid congestion.

Illinois Department of Transportation

PASS ID: *[Signature]* January 3, 2019

ENGINEER OF POLICY AND PROCEDURES

APPROVED: *[Signature]* January 3, 2019

ENGINEER OF DESIGN AND ENVIRONMENT

**PRECAST REINFORCED  
CONCRETE FLAT SLAB TOP**

(Sheet 2 of 2)

STANDARD 602601-06

CONTRACT

CAST IRON STEPS

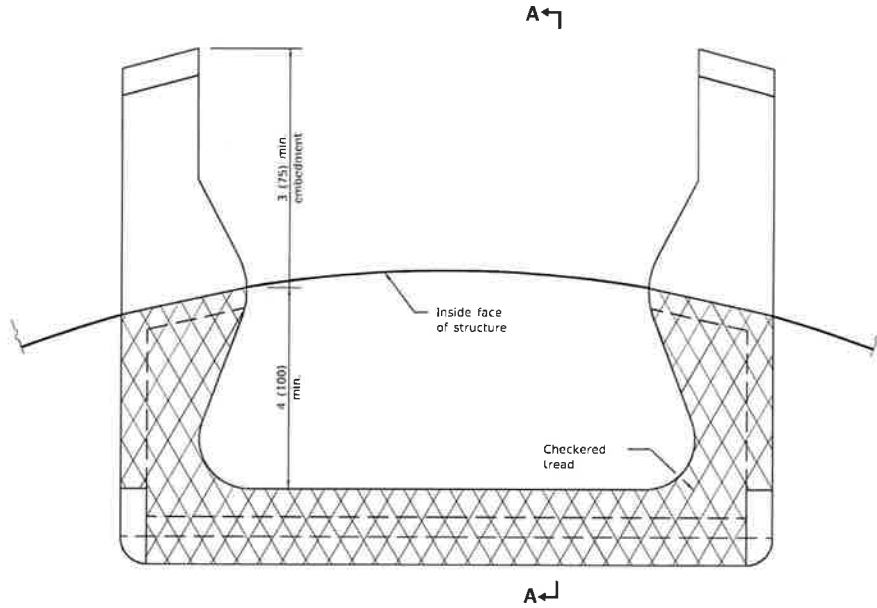

PLAN VIEW

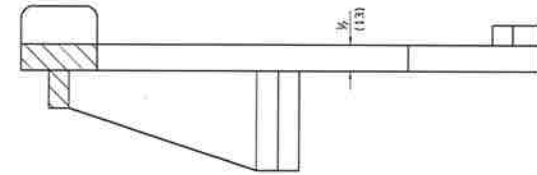

SECTION A-A

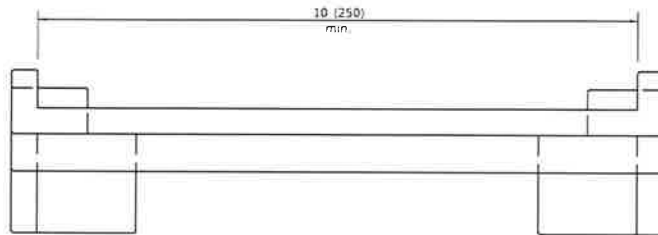

ELEVATION VIEW

All dimensions are in inches (millimeters) unless otherwise shown.

Illinois Department of Transportation

PASSED January 1, 2009

ENGINEER OF POLICY AND PROCEDURES

APPROVED February 1, 2009

ENGINEER OF DESIGN AND ESTIMATION

DATE

DATE	REVISIONS
1-1-09	Switched units to English (metric)
4-1-06	Revised title, drawings, and added plastic steps on sheet 2

MANHOLE STEPS

(Sheet 1 of 2)

STANDARD 602701-02

OWNER COPY

PLASTIC STEPS

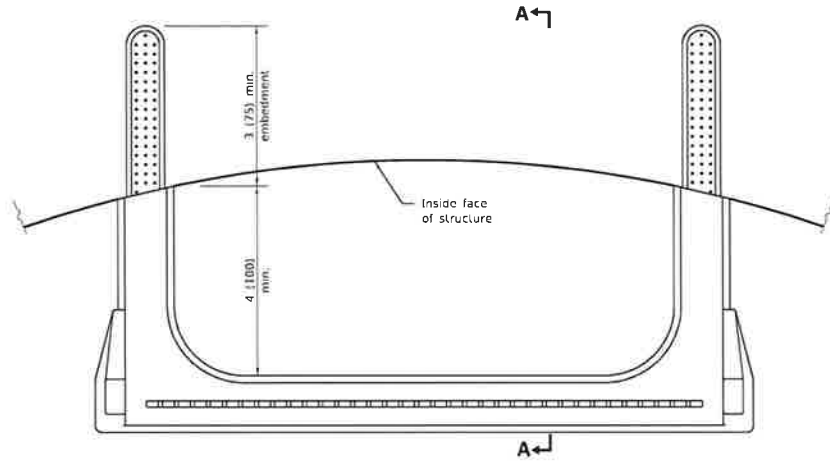

PLAN VIEW

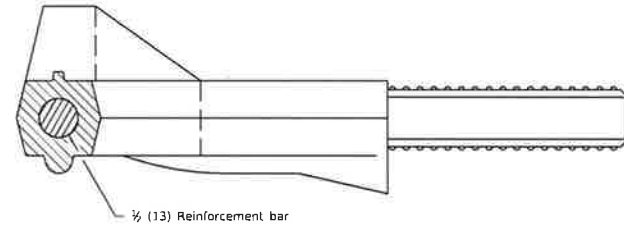

SECTION A-A

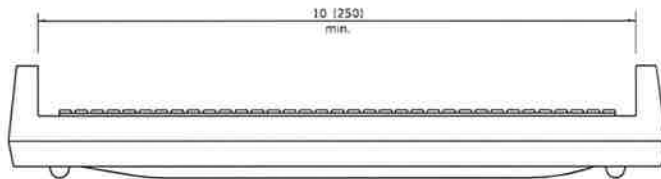

ELEVATION VIEW

Illinois Department of Transportation

ISSUED January 1, 2009

ENGINEER OF POLICY AND PROCEDURES

APPROVED January 1, 2009

ILLINOIS DEPARTMENT OF TRANSPORTATION

ISSUED 11/1/09

MANHOLE STEPS

(Sheet 2 of 2)

STANDARD 602701-02

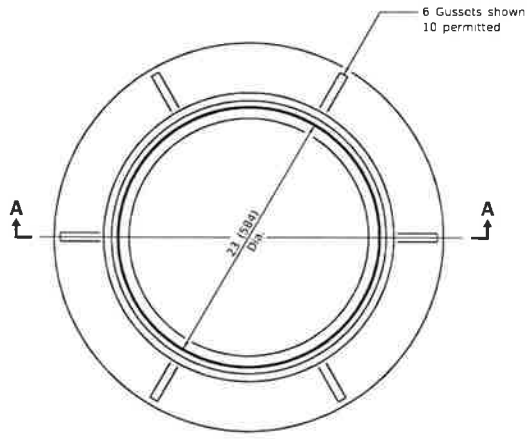

**CAST FRAME**

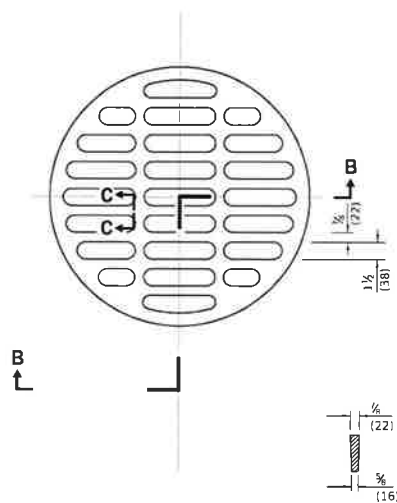

**SECTION C-C**

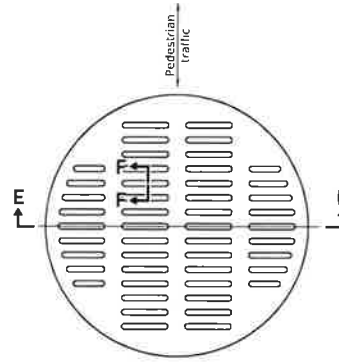

**SECTION F-F**

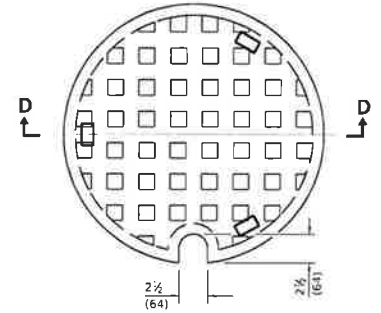

**SECTION D-D**

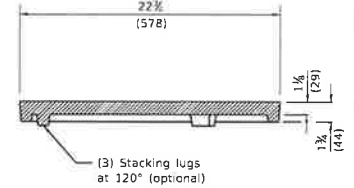

**CAST CLOSED LID**

Gray Iron Lid

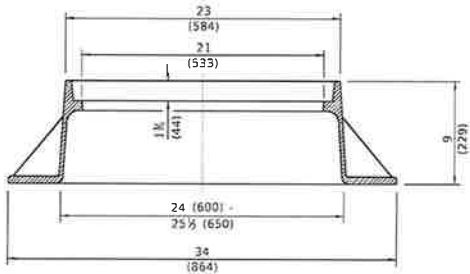

**SECTION A-A**

Gray Iron

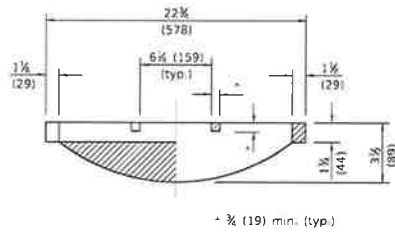

**SECTION B-B**

**CAST OPEN LID**

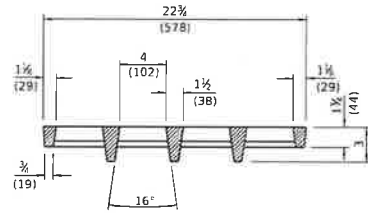

**SECTION E-E**

**ADA COMPLIANT  
CAST OPEN LID**

All dimensions are in inches (millimeters) unless otherwise shown.

Illinois Department of Transportation

PROJECT: SECURITY 7070

DESIGNER: POLY AND ASSOCIATES

APPROVED: Ministry 7030

DESIGNER OF DESIGN AND ENVIRONMENT

DATE: 1-1-20

DATE	REVISIONS
1-1-20	Revised dimension in Section B-B of cast open lid.
1-1-15	Revised dimensioning of frame. Added ADA compliant open lid.
1-1-09	Switched units to English (metric).

**FRAME AND LIDS  
TYPE 1**

**STANDARD 604001-05**

1/4" (10) Dia hole and 5/8"x5/8" (16x140) slotted hole for galvanized 1/2" (M12) bolt, nut, and washer.

Curb box adjustable from 4 1/2" (115) to 9" (225)

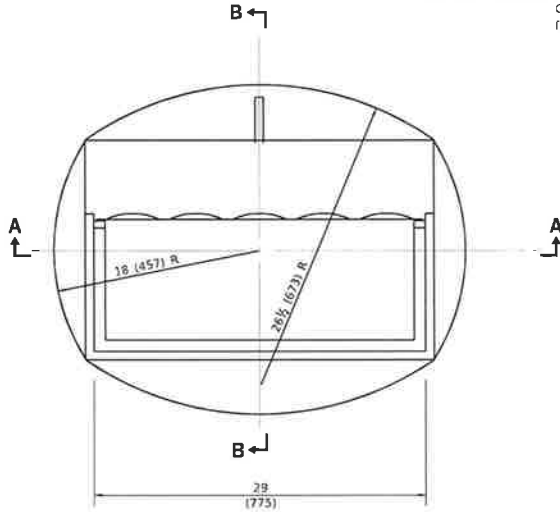

CAST FRAME

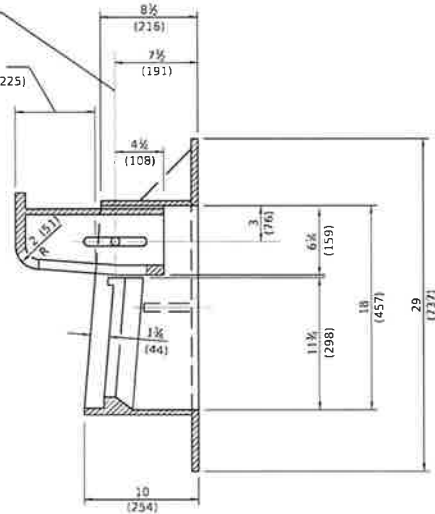

SECTION B-B

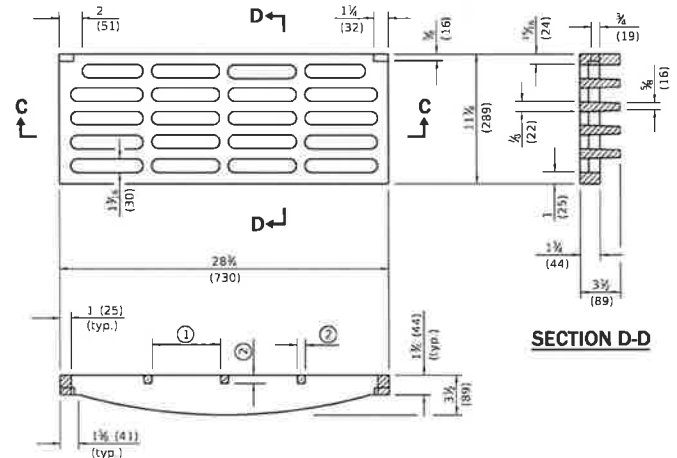

SECTION C-C

SECTION D-D

- ① = 6 1/2 (159) max (typ.)
- ② = 3/4 (19) min (typ.)

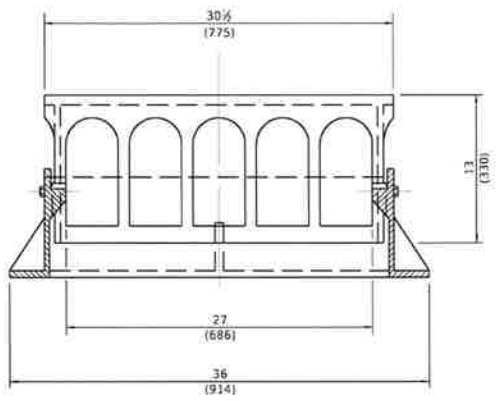

SECTION A-A

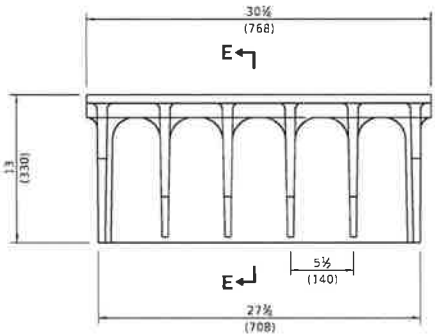

ALTERNATE CURB BOX

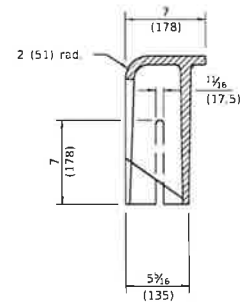

SECTION E-E

CAST GRATE

All dimensions are in inches (millimeters) unless otherwise shown.

Illinois Department of Transportation

DESIGNED BY: [Signature] 2015

ENGINEER IN CHARGE: [Signature] 2015

APPROVED BY: [Signature] 2015

ENGINEER OF DESIGN AND ENVIRONMENT

DATE	REVISIONS
1-1-15	Revised dimensions of frame and alternate curb box
4-1-09	Switched units to English (metric)

**FRAME AND GRATE  
TYPE 11**

**STANDARD 604051-04**

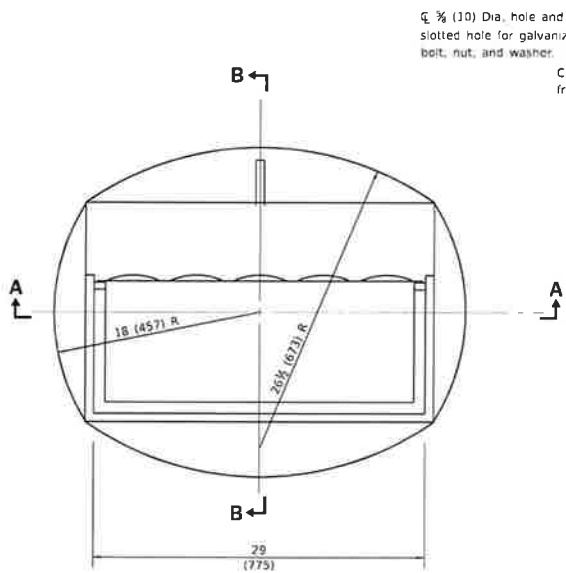

**CAST FRAME**

Ø 3/8 (10) Dia. hole and 5/8x5/8 (16x140) slotted hole for galvanized 1/2 (M12) bolt, nut, and washer.

Curb box adjustable from 4 1/2 (115) to 9 (225)

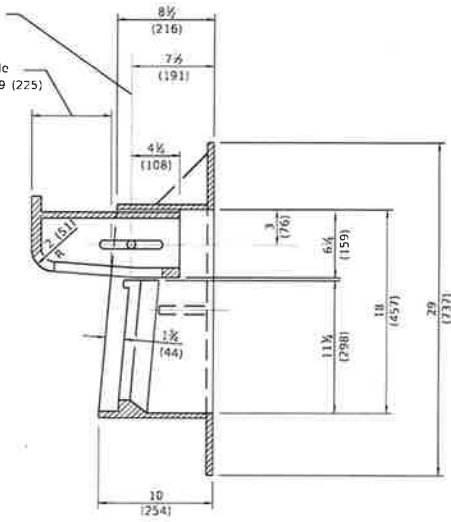

**SECTION B-B**

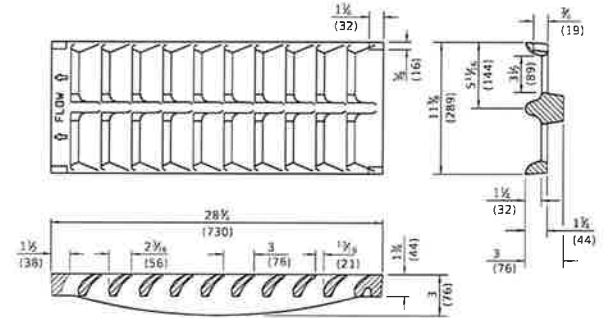

**CAST GRATE**

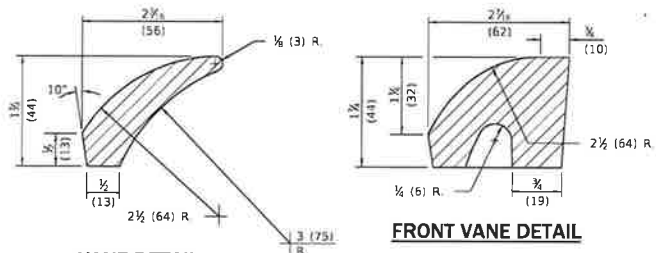

**FRONT VANE DETAIL**

**VANE DETAIL**

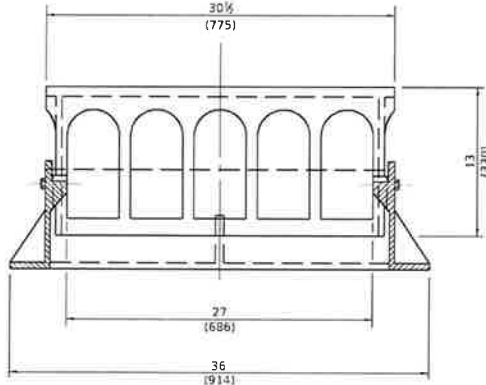

**SECTION A-A**

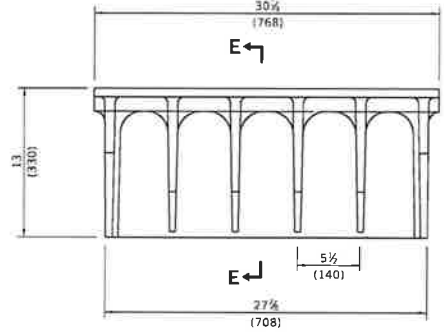

**ALTERNATE CURB BOX**

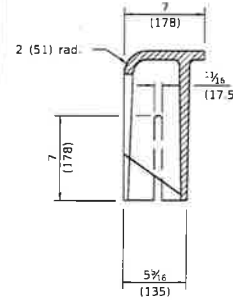

**SECTION E-E**

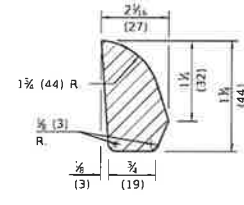

**SIDE RIB DETAIL**

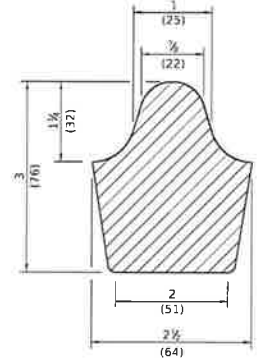

**MIDDLE RIB DETAIL**

All dimensions are in inches (millimeters) unless otherwise shown.

Illinois Department of Transportation

PASSEY: \_\_\_\_\_ 7015

Michael Beard  
ENGINEER OF POLICY AND PROCEDURES

APPROVED: \_\_\_\_\_ 2015

ENGINEER OF DESIGN AND INSPECTION

DATE: \_\_\_\_\_

DATE	REVISIONS
1-1-15	Revised dimensions of frame and alternate curb box
1-1-09	Switched units to English (metric)

**FRAME AND GRATE  
TYPE 11V**

**STANDARD 604056-04**

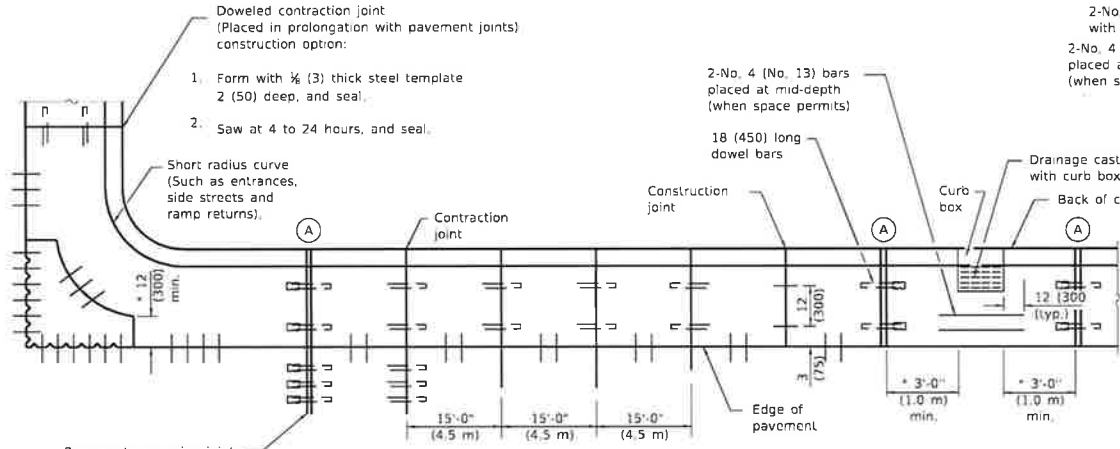

**PLAN**  
**ADJACENT TO PCC PAVEMENT OR PCC BASE COURSE**

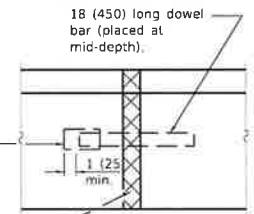
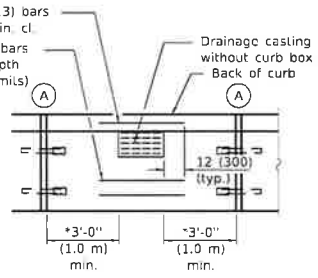

**DETAIL A**  
**EXPANSION JOINT**

\* This dimension shall be adjusted to align with joint on the adjacent pavement

Full depth & width 1 (25) - thick (min.) preformed expansion joint filler.

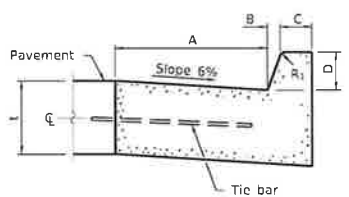

**BARRIER CURB**

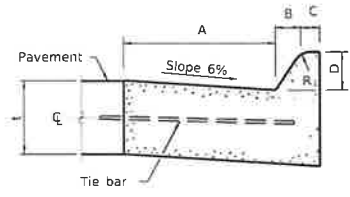

**MOUNTABLE CURB**

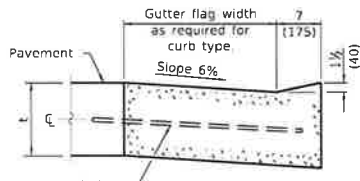

**DEPRESSED CURB (TYPICAL)**

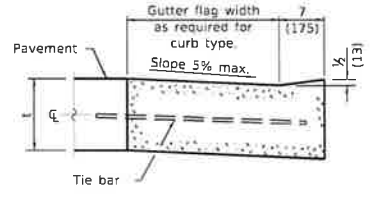

**DEPRESSED CURB ADJACENT TO CURB RAMP ACCESSIBLE TO THE DISABLED**

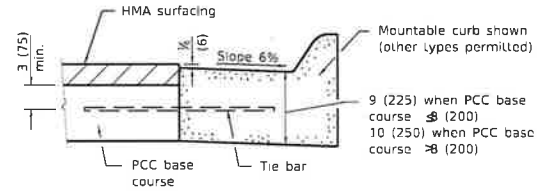

**ADJACENT TO PCC BASE COURSE WITH HMA SURFACING**

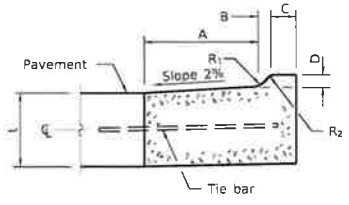

**M-2.06 (M-5.15) and M-2.12 (M-5.30)**

**GENERAL NOTES**

The bottom slope of combination curb and gutter constructed adjacent to pcc pavement shall be the same slope as the subbase or 6% when subbase is omitted.

t = Thickness of pavement.

Longitudinal joint tie bars shall be No. 6 (No. 19) at 36 (900) centers in accordance with details for longitudinal construction joint shown on Standard 420001.

A minimum clearance of 2 (50) between the end of the tie bar and the back of the curb shall be maintained.

The dowel bars shown in contraction joints will only be required for monolithic construction. See Standard 606301 for details of corner islands.

All dimensions are in inches (millimeters) unless otherwise shown.

TABLE OF DIMENSIONS BARRIER CURB					
TYPE	A	B	C	D	R <sub>1</sub>
B-6.06	6	1	6	6	1
(B-15.15)	(150)	(25)	(150)	(150)	(25)
B-6.12	12	1	6	6	1
(B-15.3)	(300)	(25)	(150)	(150)	(25)
B-6.18	18	1	6	6	1
(B-15.45)	(450)	(25)	(150)	(150)	(25)
B-6.24	24	1	6	6	1
(B-15.60)	(600)	(25)	(150)	(150)	(25)
B-9.12	12	2	5	9	1
(B-22.30)	(300)	(50)	(125)	(225)	(25)
B-9.18	18	2	5	9	1
(B-22.45)	(450)	(50)	(125)	(225)	(25)
B-9.24	24	2	5	9	1
(B-22.60)	(600)	(50)	(125)	(225)	(25)

\* For corner islands only.

TABLE OF DIMENSIONS MOUNTABLE CURB							
TYPE	A	B	C	D	R <sub>1</sub>	R <sub>2</sub>	
M-2.06	6	2	4	2	3	2	
(M-5.15)	(150)	(50)	(100)	(50)	(75)	(50)	
M-2.12	12	2	4	2	3	2	
(M-5.30)	(300)	(50)	(100)	(50)	(75)	(50)	
M-4.06	6	4	3	4	3	NA	
(M-10.15)	(150)	(100)	(75)	(100)	(75)	NA	
M-4.12	12	4	3	4	3	NA	
(M-10.30)	(300)	(100)	(75)	(100)	(75)	NA	
M-4.18	18	4	3	4	3	NA	
(M-10.45)	(450)	(100)	(75)	(100)	(75)	NA	
M-4.24	24	4	3	4	3	NA	
(M-10.60)	(600)	(100)	(75)	(100)	(75)	NA	
M-6.06	6	6	2	6	2	NA	
(M-15.15)	(150)	(150)	(50)	(150)	(50)	NA	
M-6.12	12	6	2	6	2	NA	
(M-15.30)	(300)	(150)	(50)	(150)	(50)	NA	
M-6.18	18	6	2	6	2	NA	
(M-15.45)	(450)	(150)	(50)	(150)	(50)	NA	
M-6.24	24	6	2	6	2	NA	
(M-15.60)	(600)	(150)	(50)	(150)	(50)	NA	

Illinois Department of Transportation

PASSIT

APPROVED: *Michael Bennett* January 3, 2018

ENGINEER OF POLICY AND PROGRAMS

APPROVED: *Maureen M. Davis* January 3, 2018

ENGINEER OF DESIGN AND ENVIRONMENT

SCALE: 1/8" = 1'-0"

DATE	REVISIONS
1-1-18	Revised General Note for tie bar spacing to 36 (900) cts.
1-1-15	Added B-6.06 (B-15.15) barrier curb and gutter to table (corner islands only).

**CONCRETE CURB TYPE B AND COMBINATION CONCRETE CURB AND GUTTER**

(Sheet 1 of 2)

**STANDARD 606001-07**

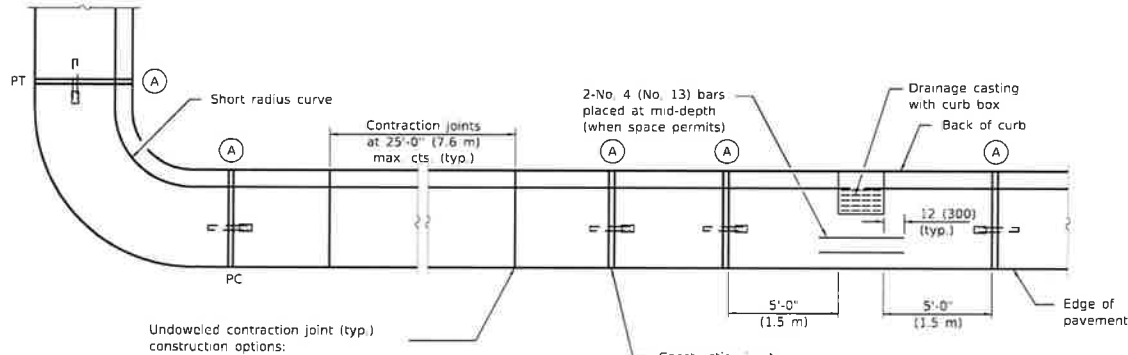

Undoweled contraction joint (typ.) construction options:

1. Form with 1/8 (3) thick steel template 2 (50) deep, and seal.
2. Saw 2 (50) deep at 4 to 24 hours, and seal.
3. Insert 3/8 (20) thick preformed joint filler full depth and width.

**PLAN**

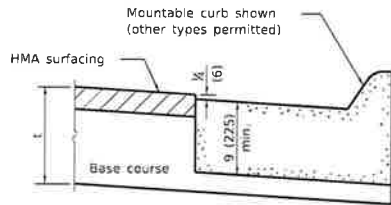
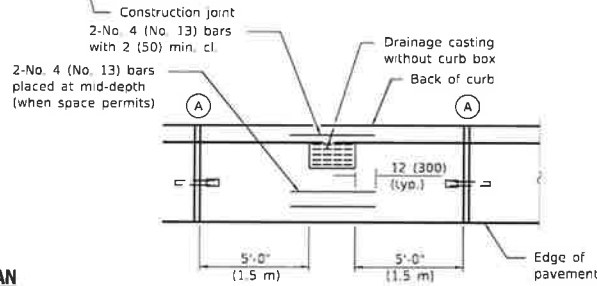

**ON DISTURBED SUBGRADE**

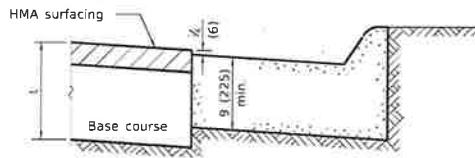

**ON UNDISTURBED SUBGRADE**

**ADJACENT TO FLEXIBLE PAVEMENT**

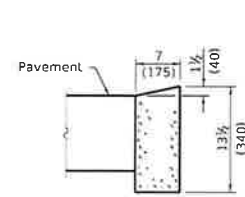

**DEPRESSED CURB**

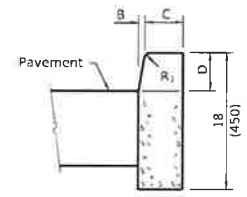

**BARRIER CURB**

**ADJACENT TO FLEXIBLE PAVEMENT**

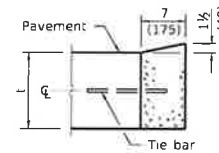

**DEPRESSED CURB**

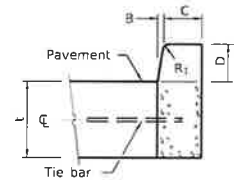

**BARRIER CURB**

**ADJACENT TO PCC PAVEMENT OR PCC BASE COURSE**

**CONCRETE CURB TYPE B**

**CONCRETE CURB TYPE B  
AND COMBINATION  
CONCRETE CURB AND GUTTER**

(Sheet 2 of 2)

**STANDARD 606001-07**

Illinois Department of Transportation

WSS: 11 2018

PREPARED BY: Michael K... 2018

APPROVED BY: ... 2018

ENGINEER: DESIGN AND ENVIRONMENT

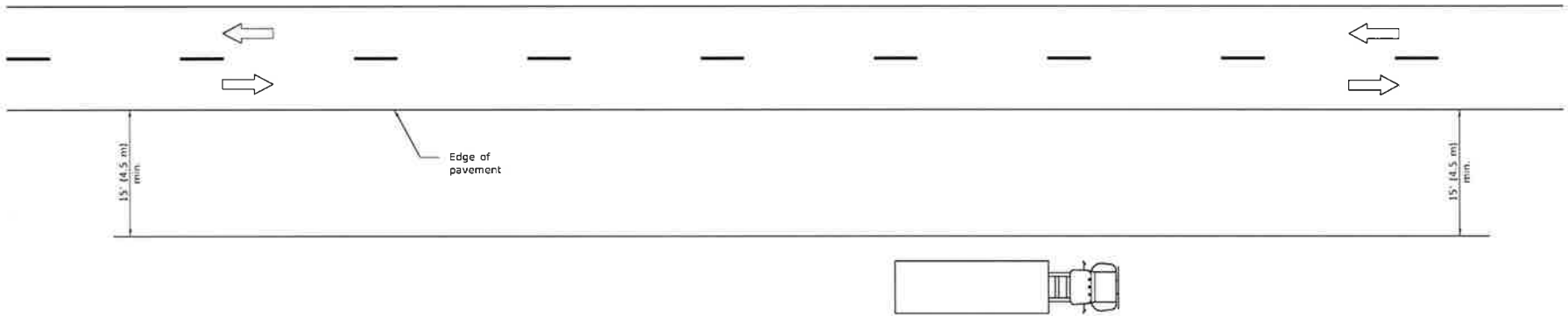

**TYPICAL APPLICATIONS**

- Landscaping work
- Utility work
- Fencing contracts and maintenance
- Cleaning culverts

**GENERAL NOTES**

This Standard is used where at all times all vehicles, equipment, workers or their activities are more than 15' (4.5 m) from the edge of pavement.

When the work operation requires that two or more work vehicles cross the 15' (4.5 m) clear zone in any one hour, traffic control shall be according to Standard 701006.

All dimensions are in inches (millimeters) unless otherwise shown.

Illinois Department of Transportation

PASSED January 1, 2009

ENGINEER OF OPERATIONS *[Signature]*

APPROVED January 1, 2009

ILLINOIS DEPARTMENT OF DESIGN AND PAVEMENT

ISSUED 1.14.09

DATE	REVISIONS
1-1-09	Switched units to English (metric)
1-1-05	Revised title and notes

**OFF-RD OPERATIONS,  
2L, 2W, MORE THAN  
15' (4.5 m) AWAY**

**STANDARD 701001-02**

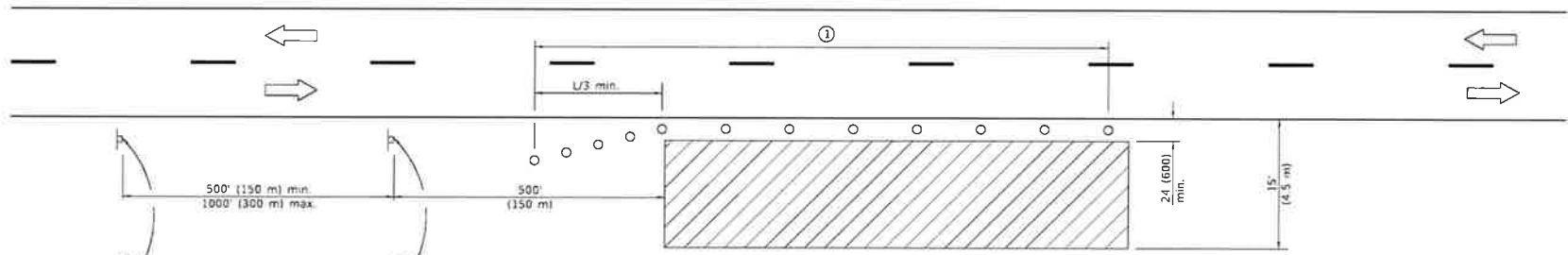

For contract construction projects  
  
 W20-1103(0)-48



For maintenance and utility projects  
  
 W20-1(0)-48



**TYPICAL APPLICATIONS**

- Utility operations
- Culvert extensions
- Side slope changes
- Guardrail installation and maintenance
- Delineator installation
- Landscaping operations
- Shoulder repair
- Sign installation and maintenance

**SYMBOLS**

-  Work area
-  Sign
-  Cone, drum or barricade

① When the work operation exceeds one hour, cones, drums or barricades shall be placed at 25' (8 m) centers for L/3 distance, and at 50' (15 m) centers through the remainder of the work area.

**GENERAL NOTES**

This Standard is used where any vehicles, equipment, workers or their activities will encroach in the area 15' (4.5 m) to 24' (600) from the edge of pavement.

Calculate L as follows

**SPEED LIMIT**

**FORMULAS**

- 40 mph (70 km/h) or less:
- 45 mph (80 km/h) or greater:

$$L = \frac{WS^2}{60} \quad L = \frac{WS^2}{150}$$

$$L = (W)(S) \quad L = 0.65(W)(S)$$

- W = Width of offset in feet (meters)
- S = Normal posted speed mph (km/h).

All dimensions are in inches (millimeters) unless otherwise shown.

DATE	REVISIONS
1-1-14	Revised workers sign number to agree with current MUTCD.
1-1-13	Omitted text 'WORKERS' sign

**OFF-ROAD OPERATIONS, 2L, 2W, 15' (4.5 m) TO 24" (600 mm) FROM PAVEMENT EDGE**

**STANDARD 701006-05**

Illinois Department of Transportation

PASS IT 2014

ENGINEER OF SAFETY ENGINEERING

APPROVED 2014

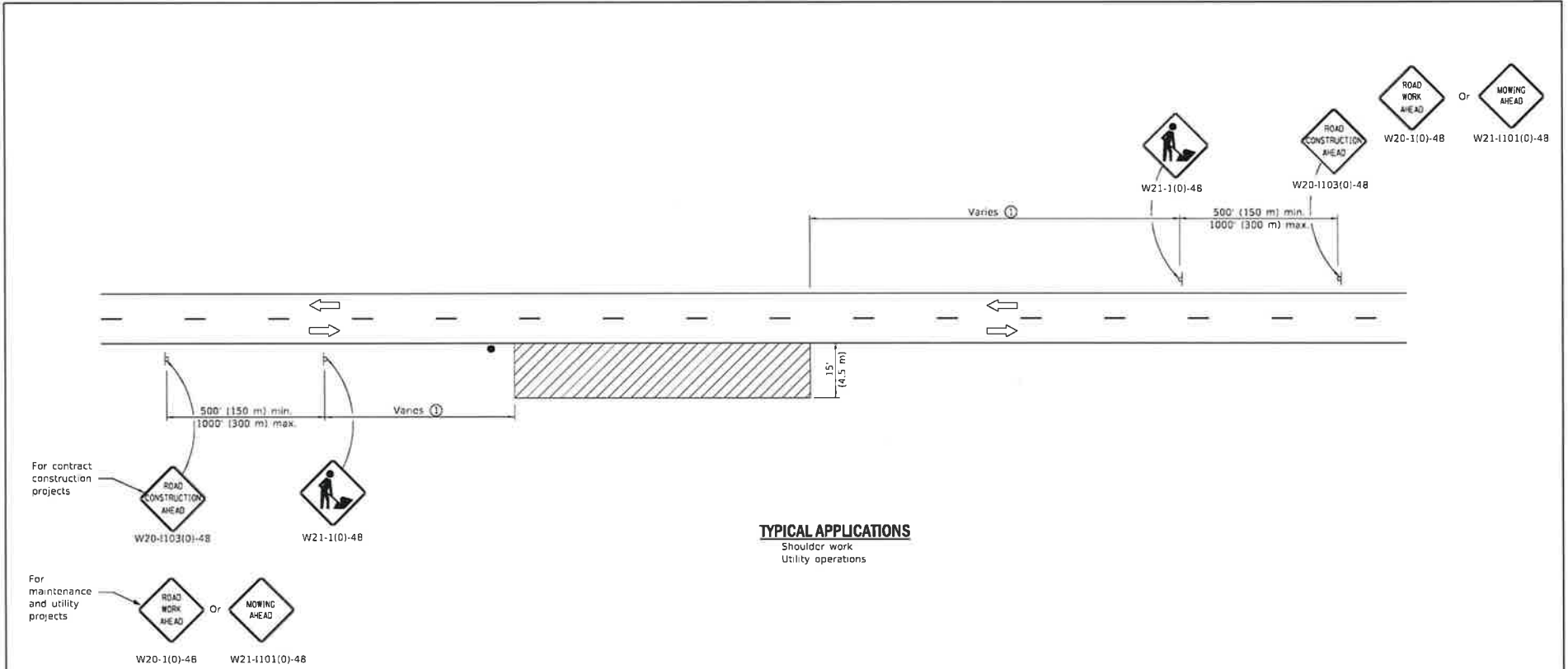

REGISTER OF TRAFFIC AND ENVIRONMENT

16 1.1 OFFICE



**TYPICAL APPLICATIONS**  
Shoulder work  
Utility operations

**SYMBOLS**

-  Work area
-  Sign
-  Flagger with traffic control sign when required

**GENERAL NOTES**

This Standard is used where at any time, any vehicle, equipment, workers or their activities require an intermittent or continuous moving operation on the shoulder, where the average speed is 1 mph (2 km/h) or less.

When the work operation does not exceed 60 minutes, traffic control may be according to Standard 701301.

All dimensions are in inches (millimeters) unless otherwise shown.

① Minimum distance is 200' (60 m). Maximum distance to be determined by the Engineer but should not exceed 1/2 the length required for one normal working day's operation, or 4 miles (6.4 km) whichever is less.

Illinois Department of Transportation

ISSUED: [Signature] 2014  
 ENGINEER OF SAFETY ENGINEERING

APPROVED: [Signature] 2014  
 ENGINEER OF DESIGN AND MAINTENANCE

DATE	REVISIONS
1-1-14	Revised workers sign number to agree with current MUTCD.
1-1-13	Omitted text 'WORKERS' sign.

**OFF-RD MOVING OPERATIONS, 2L, 2W, DAY ONLY**

STANDARD 701011-04

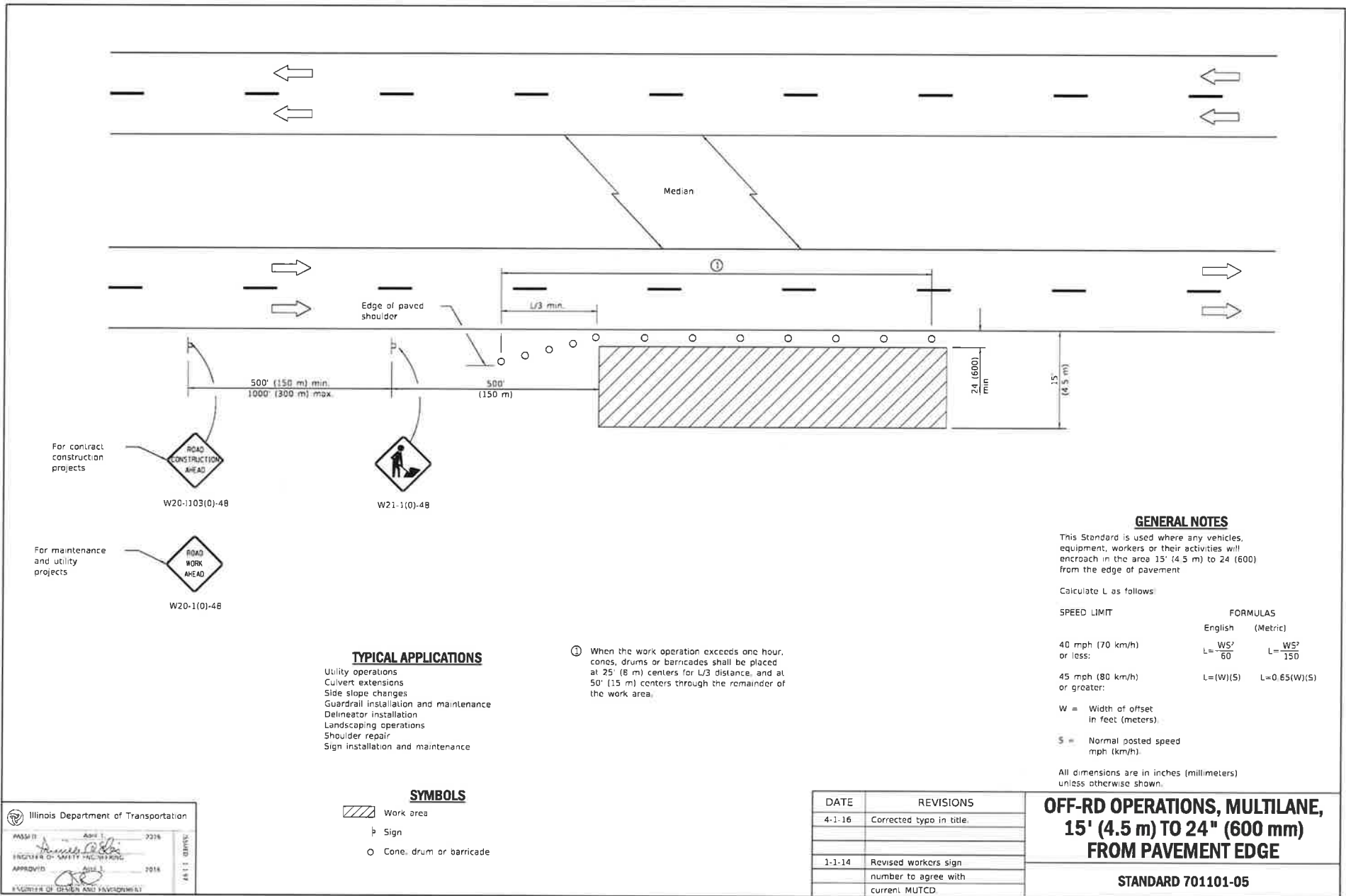

**GENERAL NOTES**

This Standard is used where any vehicles, equipment, workers or their activities will encroach in the area 15' (4.5 m) to 24' (600 mm) from the edge of pavement

Calculate L as follows:

SPEED LIMIT	FORMULAS	
	English	(Metric)
40 mph (70 km/h) or less:	$L = \frac{WS^2}{60}$	$L = \frac{WS^2}{150}$
45 mph (80 km/h) or greater:	$L = (W)(S)$	$L = 0.65(W)(S)$

W = Width of offset in feet (meters)  
 S = Normal posted speed mph (km/h).

All dimensions are in inches (millimeters) unless otherwise shown.

**TYPICAL APPLICATIONS**

- Utility operations
- Culvert extensions
- Side slope changes
- Guardrail installation and maintenance
- Delineator installation
- Landscaping operations
- Shoulder repair
- Sign installation and maintenance

① When the work operation exceeds one hour, cones, drums or barricades shall be placed at 25' (8 m) centers for L/3 distance, and at 50' (15 m) centers through the remainder of the work area.

**SYMBOLS**

- Work area
- Sign
- Cone, drum or barricade

DATE	REVISIONS
4-1-16	Corrected typo in title.
1-1-14	Revised workers sign number to agree with current MUTCD

**OFF-ROAD OPERATIONS, MULTILANE, 15' (4.5 m) TO 24" (600 mm) FROM PAVEMENT EDGE**

**STANDARD 701101-05**

Illinois Department of Transportation

PROJECT: 03216

APPROVED: [Signature]

DATE: 2016

ENGINEER OF DESIGN AND ENVIRONMENT

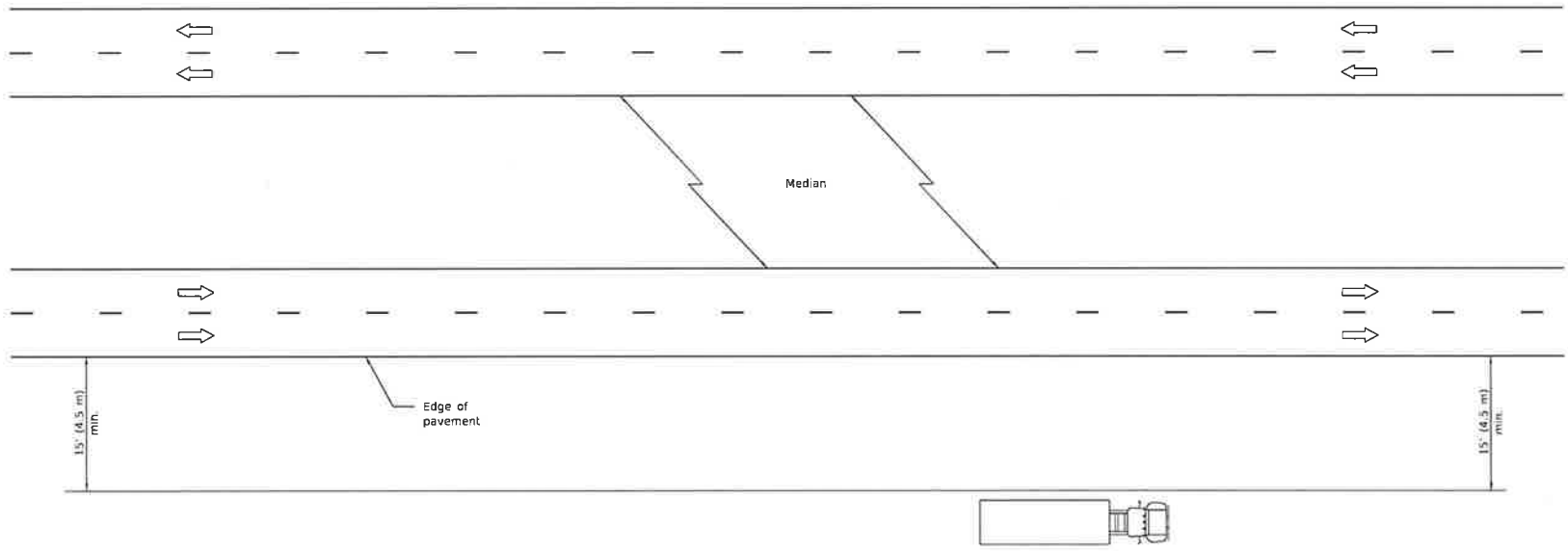

**TYPICAL APPLICATIONS**

- Landscaping work
- Utility work
- Fencing contracts

**GENERAL NOTES**

This Standard is used where at all times all vehicles, equipment, workers or their activities are more than 15' (4.5 m) from the edge of pavement.

When the work operation requires that two or more work vehicles cross the 15' (4.5 m) clear zone in any one hour, traffic control shall be according to Standard 701101.

This Standard also applies to work performed in the median more than 15' (4.5 m) from either pavement.

All dimensions are in inches (millimeters) unless otherwise shown.

**OFF-RD OPERATIONS, MULTILANE,  
MORE THAN 15' (4.5 m) AWAY**

**STANDARD 701106-02**

Illinois Department of Transportation

PASSED January 3, 2009

ENGINEER OF OPERATIONS

APPROVED January 3, 2009

ENGINEER OF DESIGN AND DEVELOPMENT

DATE	REVISIONS
1-1-05	Switched units to English (metric).
1-1-05	Revised title.

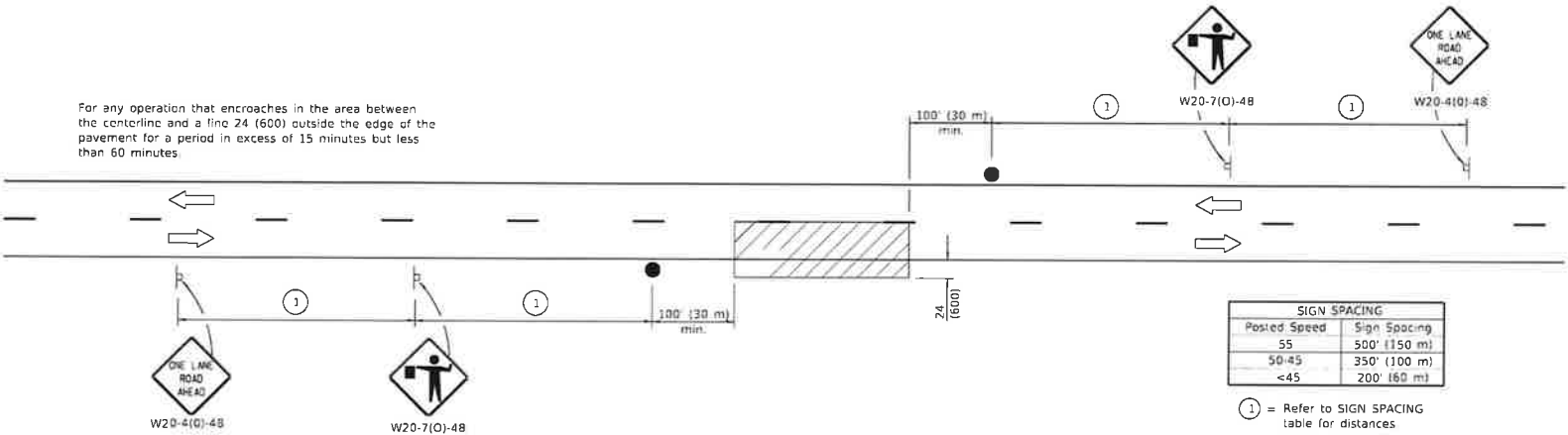
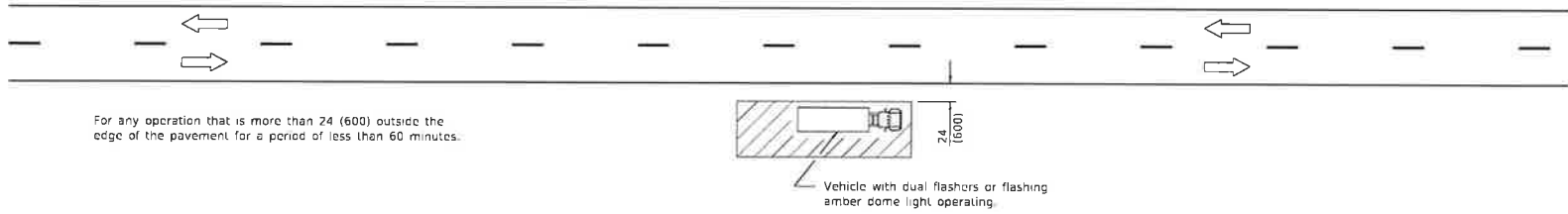
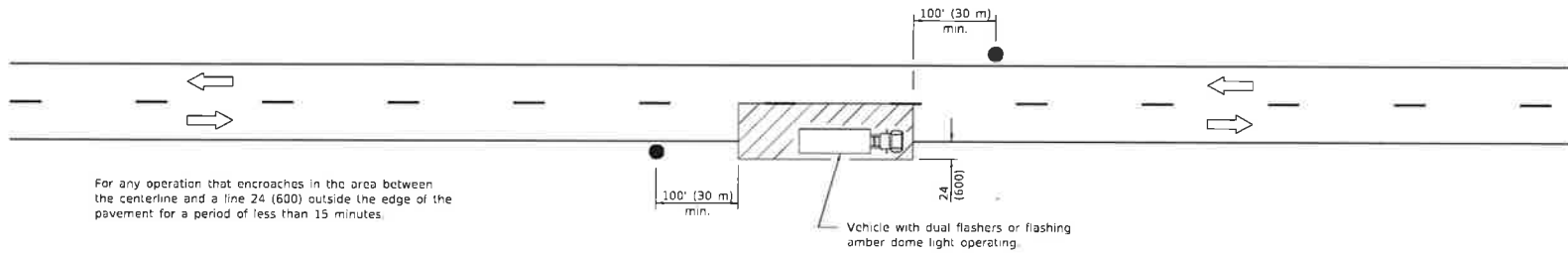

**TYPICAL APPLICATIONS**

- Marking patches
- Field survey
- String line
- Utility operations
- Cleaning up debris on pavement

**SYMBOLS**

- Work area
- Sign on portable or permanent support
- Flagger with traffic control sign

All dimensions are in inches (millimeters) unless otherwise shown.

Illinois Department of Transportation

ISSUED: December 1, 2011

ENGINEER OF SAFETY ENGINEERING

APPROVED: January 1, 2011

ENGINEER OF DESIGN AND DEVELOPMENT

DATE	REVISIONS
1-1-11	Revised flagger sign
1-1-09	Switched units to English (metric)

**LANE CLOSURE, 2L, 2W, SHORT TIME OPERATIONS**

STANDARD 701301-04

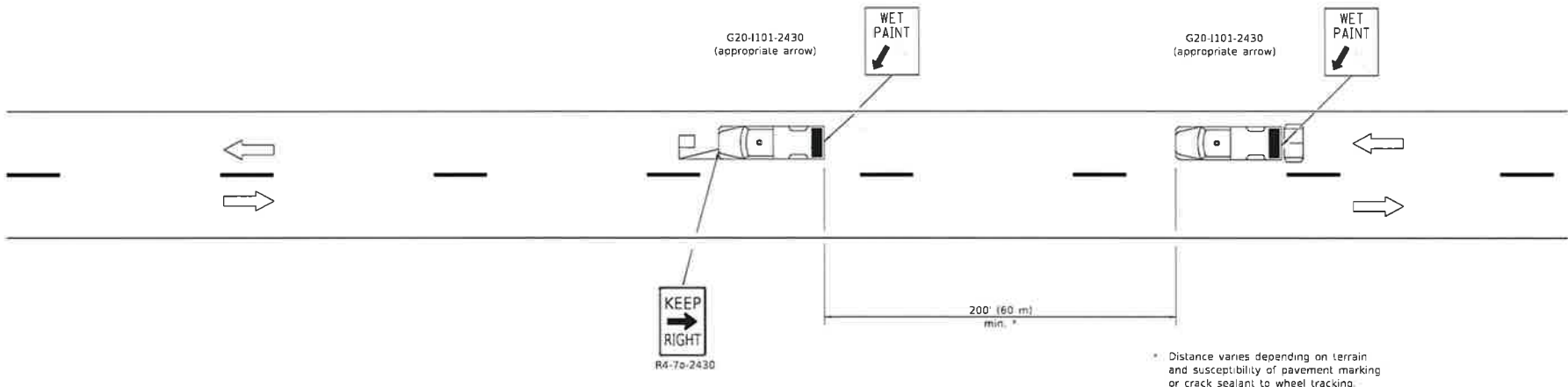

**TYPICAL APPLICATIONS**

- Landscaping work
- Utility work
- Pavement marking
- Weed spraying
- Roadmeter measurements
- Debris cleanup
- Crack pouring

**SYMBOLS**

- Arrow board (Hazard Mode only)
- Truck with headlights, emergency flashers and flashing amber light. (visible from all directions)
- 18x18 (450x450) min. orange flag (use when guide wheel is used)
- Truck mounted attenuator

**GENERAL NOTES**

This Standard is used where any vehicle, equipment, workers or their activities will require a continuous moving operation where the average speed is greater than 3 mph (5 km/h).

For shoulder operations not encroaching on the pavement, use DETAIL A, Standard 701426.

All dimensions are in inches (millimeters) unless otherwise shown.

DATE	REVISIONS
1-1-09	Switched units to English (metric) Omitted
	Pass With Care sign
1-1-00	Elim. speed restrictions in Standard title.

**LANE CLOSURE 2L, 2W MOVING OPERATIONS-DAY ONLY**

**STANDARD 701311-03**

Illinois Department of Transportation

PASSED: January 1, 2009

ISSUED: 1-1-09

ENGINEER OF OPERATIONS: *[Signature]*

APPROVED: January 1, 2009

*[Signature]*

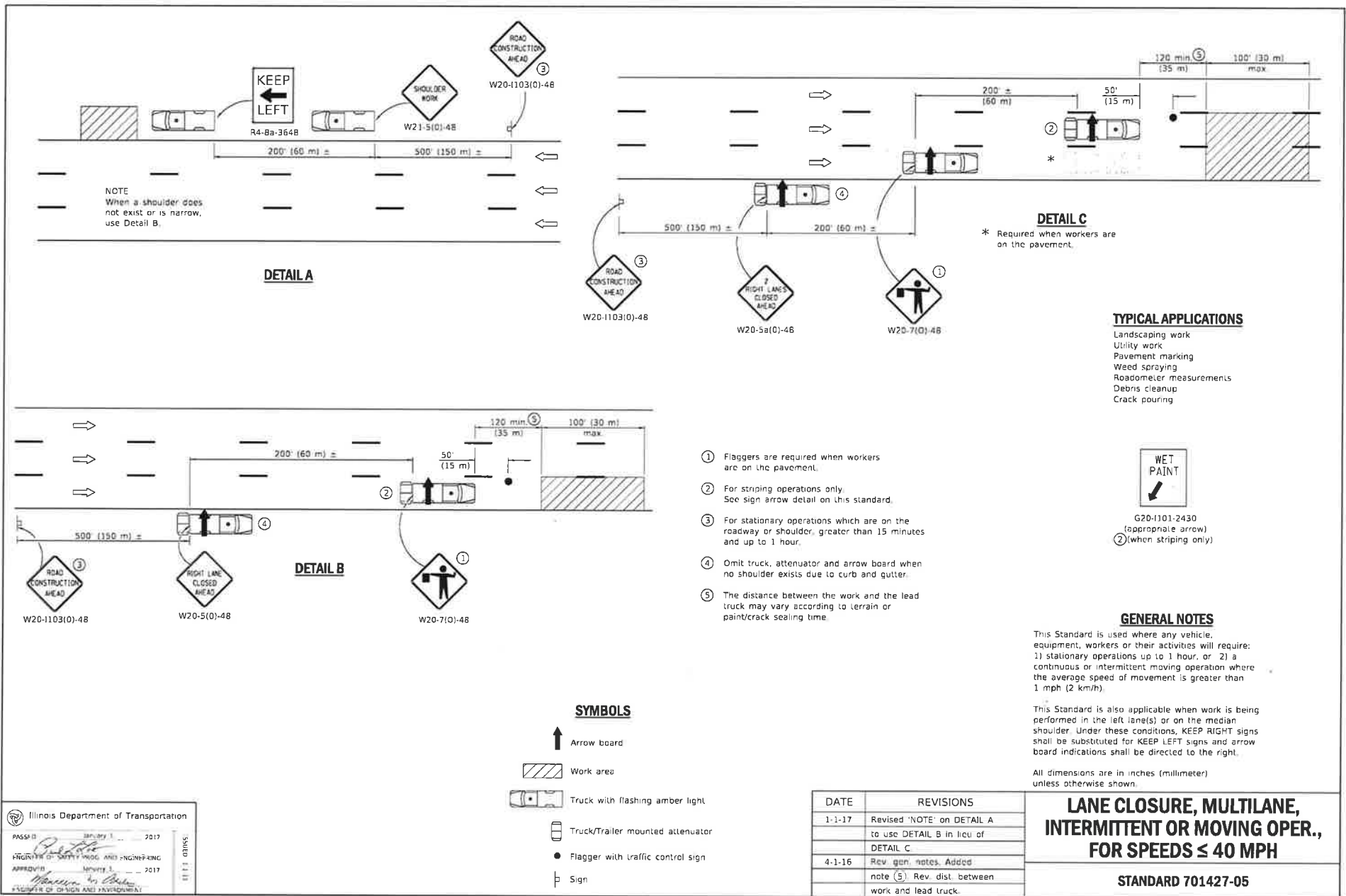

NOTE  
When a shoulder does not exist or is narrow, use Detail B.

DETAIL A

DETAIL B

DETAIL C

\* Required when workers are on the pavement.

**TYPICAL APPLICATIONS**

- Landscaping work
- Utility work
- Pavement marking
- Weed spraying
- Roadometer measurements
- Debris cleanup
- Crack pouring



G20-1101-2430 (appropriate arrow)  
② (when striping only)

- ① Flaggers are required when workers are on the pavement.
- ② For striping operations only. See sign arrow detail on this standard.
- ③ For stationary operations which are on the roadway or shoulder, greater than 15 minutes and up to 1 hour.
- ④ Omit truck, attenuator and arrow board when no shoulder exists due to curb and gutter.
- ⑤ The distance between the work and the lead truck may vary according to terrain or paint/crack sealing time.

**GENERAL NOTES**

This Standard is used where any vehicle, equipment, workers or their activities will require: 1) stationary operations up to 1 hour, or 2) a continuous or intermittent moving operation where the average speed of movement is greater than 1 mph (2 km/h).

This Standard is also applicable when work is being performed in the left lane(s) or on the median shoulder. Under these conditions, KEEP RIGHT signs shall be substituted for KEEP LEFT signs and arrow board indications shall be directed to the right.

All dimensions are in inches (millimeter) unless otherwise shown.

**SYMBOLS**

- Arrow board
- Work area
- Truck with flashing amber light
- Truck/trailer mounted attenuator
- Flagger with traffic control sign
- Sign

DATE	REVISIONS
1-1-17	Revised 'NOTE' on DETAIL A to use DETAIL B in lieu of DETAIL C
4-1-16	Rev. gen. notes. Added note ⑤. Rev. dist. between work and lead truck.

**LANE CLOSURE, MULTILANE, INTERMITTENT OR MOVING OPER., FOR SPEEDS ≤ 40 MPH**

STANDARD 701427-05

Illinois Department of Transportation  
 PASS # 01 January 1, 2017  
 HIGHWAY DESIGN, PLANNING AND ENGINEERING  
 APPROVED: [Signature] February 3, 2017  
 ENGINEER OF DESIGN AND ENVIRONMENT

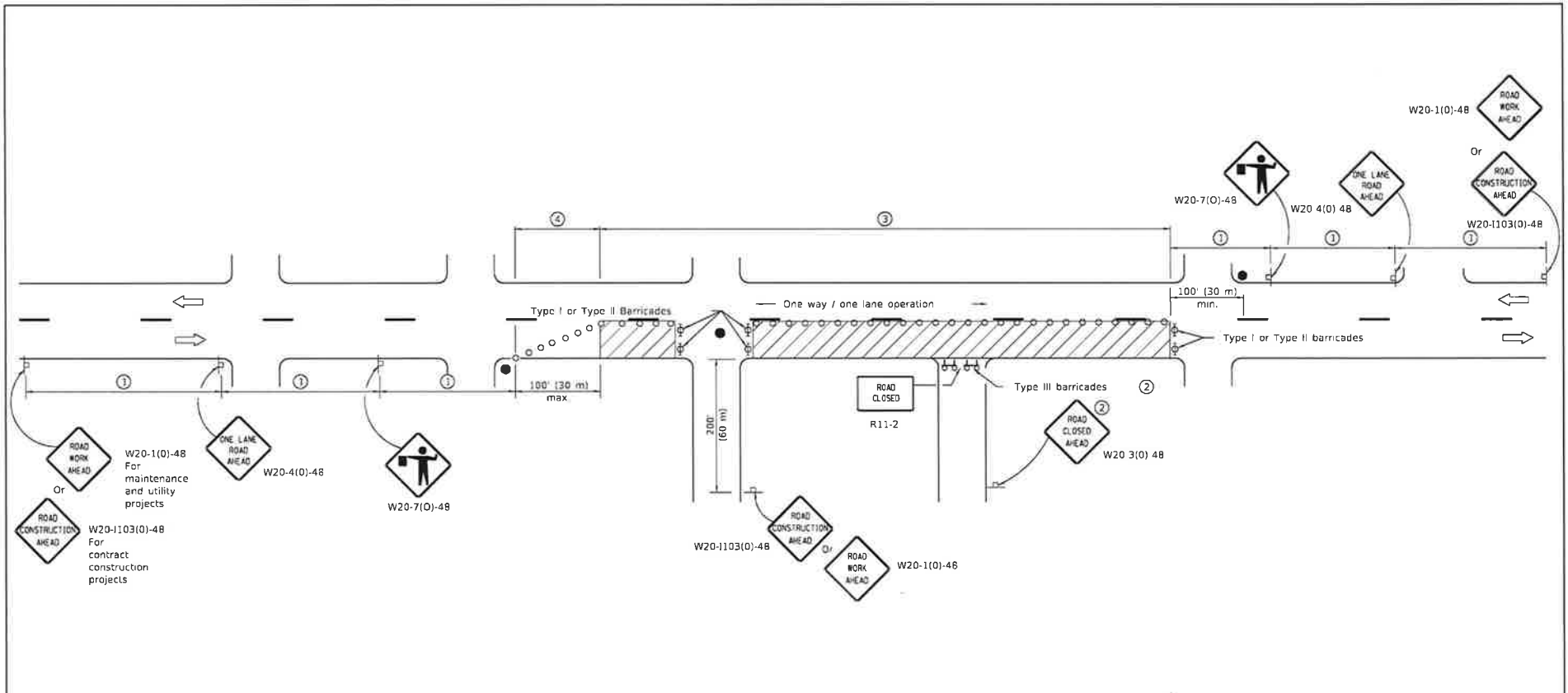

SIGN SPACING	
Posted Speed	Sign Spacing
55	500' (150 m)
50-45	350' (100 m)
<45	200' (60 m)

**SYMBOLS**

- Work area
- Cone, drum or barricade (not required for moving operations)
- Sign on portable or permanent support
- Flagger with traffic control sign
- Barricade or drum with flashing light
- Type III barricade with flashing lights

- ① Refer to SIGN SPACING TABLE for distances
- ② For approved sideroad closures.
- ③ Cones at 25' (8 m) centers for 250' (75 m). Additional cones may be placed at 50' (15 m) centers. When drums or Type I or Type II barricades are used, the interval between devices may be doubled.
- ④ Cones, drums or barricades at 20' (6 m) centers.

**GENERAL NOTES**

This Standard is used where at any time, day or night, any vehicle, equipment, workers or their activities encroach on the pavement requiring the closure of one traffic lane in an urban area.

All dimensions are in inches (millimeters) unless otherwise shown.

Illinois Department of Transportation

PASSE-D: \_\_\_\_\_ 2011

ENGINEER OF SAFETY ENGINEERING: *James C. [Signature]*

APPROVED BY: \_\_\_\_\_ 2011

PLATE: 000000

ENGINEER OF DESIGN AND REVISIONS

DATE	REVISIONS
1-1-11	Revised flagger sign.
1-1-09	Switched units to English (metric).
	Corrected sign No.'s

**URBAN LANE CLOSURE,  
2L, 2W, UNDIVIDED**

**STANDARD 701501-06**

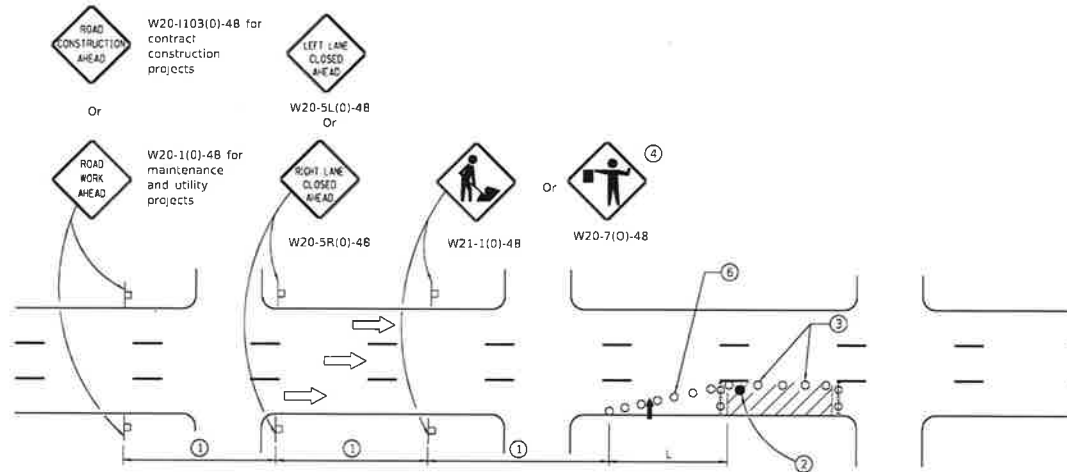

SIGN SPACING	
Posted Speed	Sign Spacing
55	500 (150 m)
50-45	350 (100 m)
<45	200 (60 m)

**SYMBOLS**

- Arrow board
- Cone, drum or barricade
- Sign on portable or permanent support
- Work area
- Barricade or drum with flashing light
- Type III barricade with flashing lights
- Flagger with traffic control sign.

- ① Refer to SIGN SPACING TABLE for distances
- ② Required for speeds > 40 MPH
- ③ Cones at 25' (8 m) centers for 250' (75 m). Additional cones may be placed at 50' (15 m) centers. When drums or Type I or Type II barricades are used, the interval between devices may be doubled.
- ④ Use flagger sign only when flagger is present.
- ⑤ For approved sideroad closures.
- ⑥ Cones, drums or barricades at 20' (6 m) in taper.

**GENERAL NOTES**

This Standard is used where at any time, day or night, any vehicle, equipment, workers or their activities encroach on the pavement during shoulder operations or where construction requires lane closures in urban areas.

Calculate L as follows:

SPEED LIMIT	FORMULAS	
	English	(Metric)
40 mph (70 km/h) or less:	$L = \frac{WS^2}{60}$	$L = \frac{WS^2}{150}$
45 mph (80 km/h) or greater:	$L = (W)(S)$	$L = 0.65(W)(S)$

W = Width of offset in feet (meters).  
S = Normal posted speed mph (km/h).

All dimensions are in inches (millimeters) unless otherwise shown.

Illinois Department of Transportation

ISSUED: 10-1-14 2014

ENGINEER OF SAFETY ENGINEERING: [Signature]

APPROVED: [Signature] 2014

ENGINEER OF DESIGN AND ENVIRONMENT

DATE: 10-1-14

DATE	REVISIONS
1-1-14	Revised workers sign number to agree with current MUTCD
1-1-13	Omitted text 'WORKERS' sign

**URBAN LANE CLOSURE, MULTILANE, 1W OR 2W WITH NONTRAVERSABLE MEDIAN**  
(Sheet 1 of 2)

**STANDARD 701601-09**

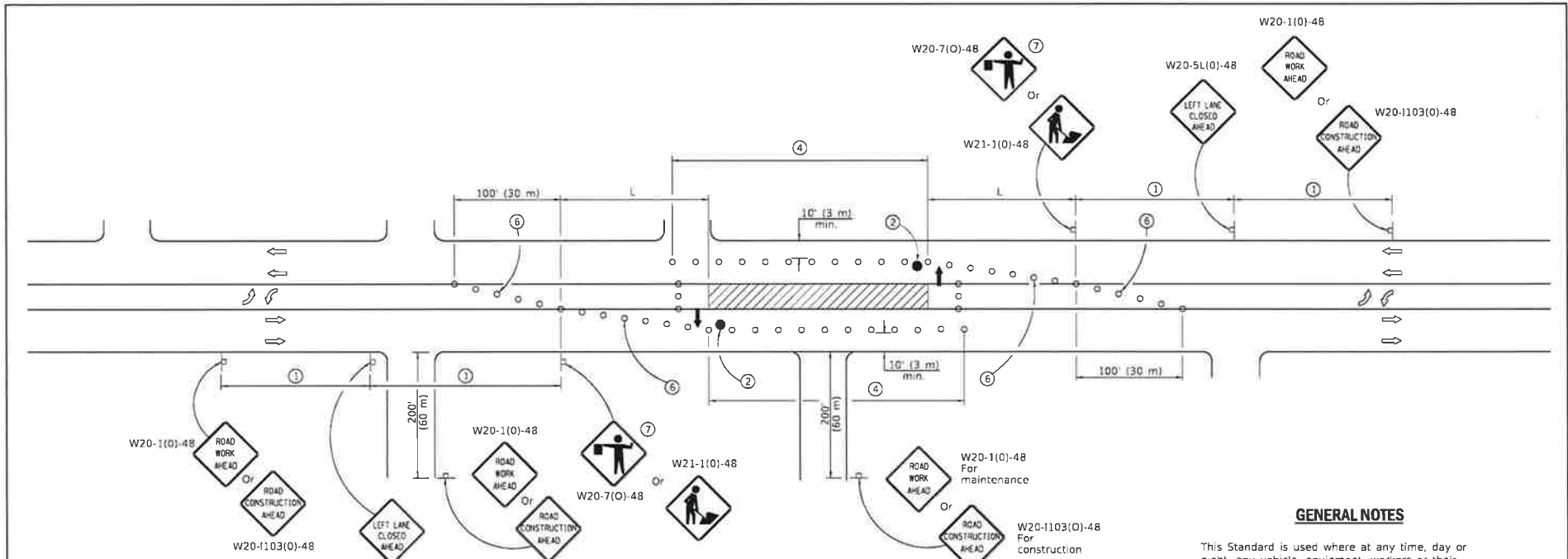

SIGN SPACING	
Posted Speed	Sign Spacing
55	500' (150 m)
50-45	350' (100 m)
<45	200' (60 m)

**SYMBOLS**

- Arrow board
- Work area
- Barricade or drum with steady burning monidirectional light
- Flagger with traffic control sign
- Cone, drum or barricade
- Sign on portable or permanent support
- Type III barricade with flashing lights

**CASE I**

- ① Refer to SIGN SPACING TABLE for distances.
- ② Required for speeds > 40 mph (70 km/h).
- ③ Required if work exceeds 500' (164 m) or 1 block, repeat every 1 mile (1.6 km).
- ④ Cones at 25' (8 m) centers for 250' (75 m) on approach. Additional cones may be placed at 50' (15 m) centers. When drums or type I or II barricades are used, the interval between devices may be doubled.
- ⑤ For approved sideroad closures.
- ⑥ Cones, drums or barricades at 20' (6 m) centers in taper.
- ⑦ Use flagger sign only when flagger is present.

**GENERAL NOTES**

This Standard is used where at any time, day or night, any vehicle, equipment, workers or their activities encroach on the pavement requiring the closure of one traffic lane in an Urban area.

If the work operation is performed between 9:00 a.m. and 3:00 p.m. and does not exceed 15 min. Traffic protection shall be as shown for Standard 701426.

Calculate L as follows:

**SPEED LIMIT**

40 mph (70 km/h) or less:	$L = \frac{WS^2}{60}$	<b>FORMULAS</b>	English (Metric)
45 mph (80 km/h) or greater:	$L = (W)(S)$	$L = 0.65(W)(S)$	

W = Width of offset in feet (meters).  
 S = Normal posted speed mph (km/h).

All dimensions are in inches (millimeters) unless otherwise shown.

Illinois Department of Transportation

APPROVED: [Signature] January 1, 2019  
 ENGINEER OF SAFETY AND ENGINEERING

APPROVED: [Signature] January 1, 2019  
 ENGINEER OF DESIGN AND ENVIRONMENT

DATE	REVISIONS
1-1-19	Revised to allow cones at night.
1-1-18	Moved arrow boards into closed lanes for CASE I.

**URBAN LANE CLOSURE, MULTILANE, 2W WITH BIDIRECTIONAL LEFT TURN LANE**  
 (Sheet 1 of 4)

**STANDARD 701602-10**

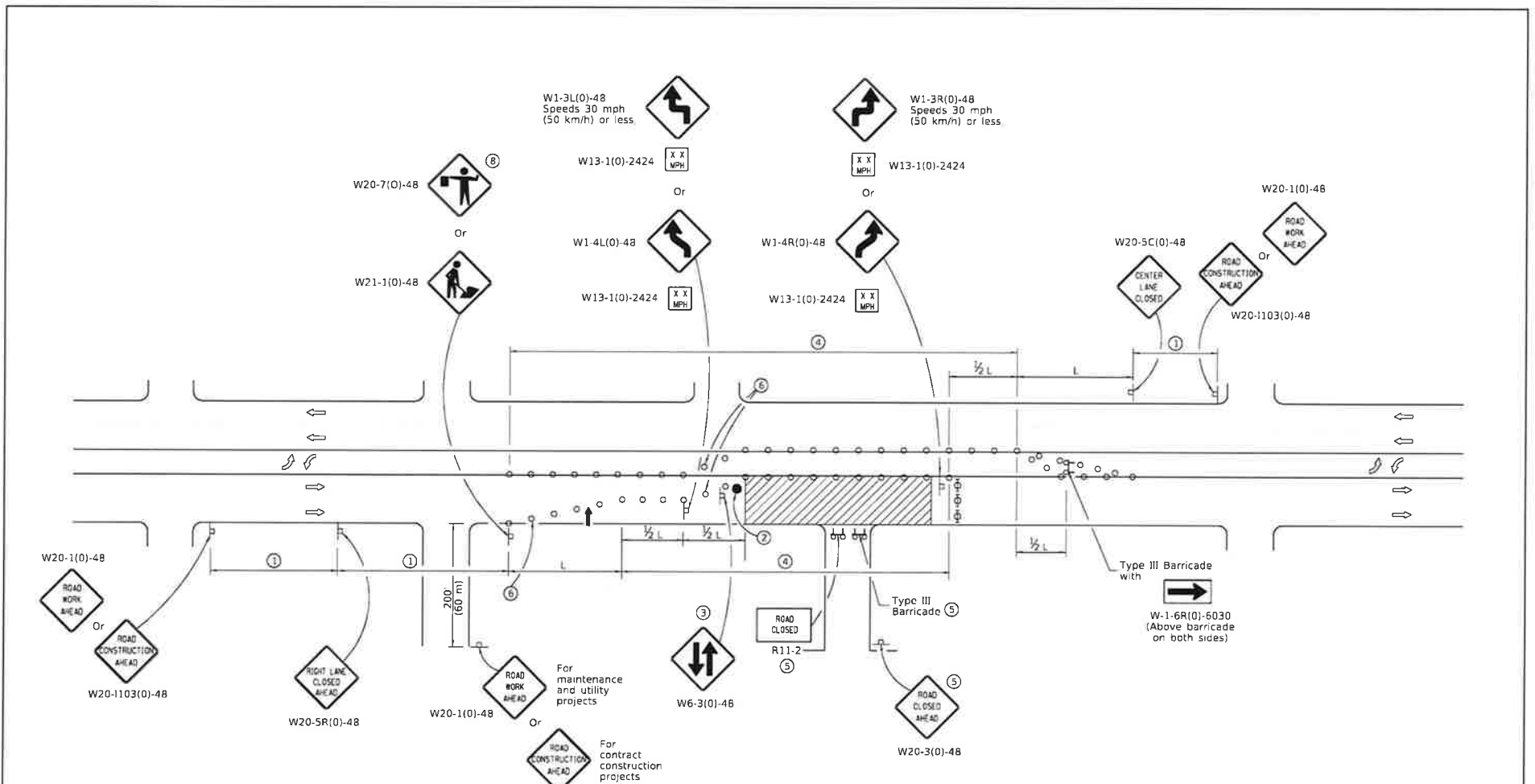

CASE II

Illinois Department of Transportation

APPROVED: *[Signature]* January 1, 2019  
 ENGINEER OF SAFETY PROG AND ENGINEERING

APPROVED: *[Signature]* January 1, 2019  
 ENGINEER OF DESIGN AND PAVEMENT

FILED OFFICE

**URBAN LANE CLOSURE,  
 MULTILANE, 2W WITH  
 BIDIRECTIONAL LEFT TURN LANE**

(Sheet 2 of 4)

**STANDARD 701602-10**

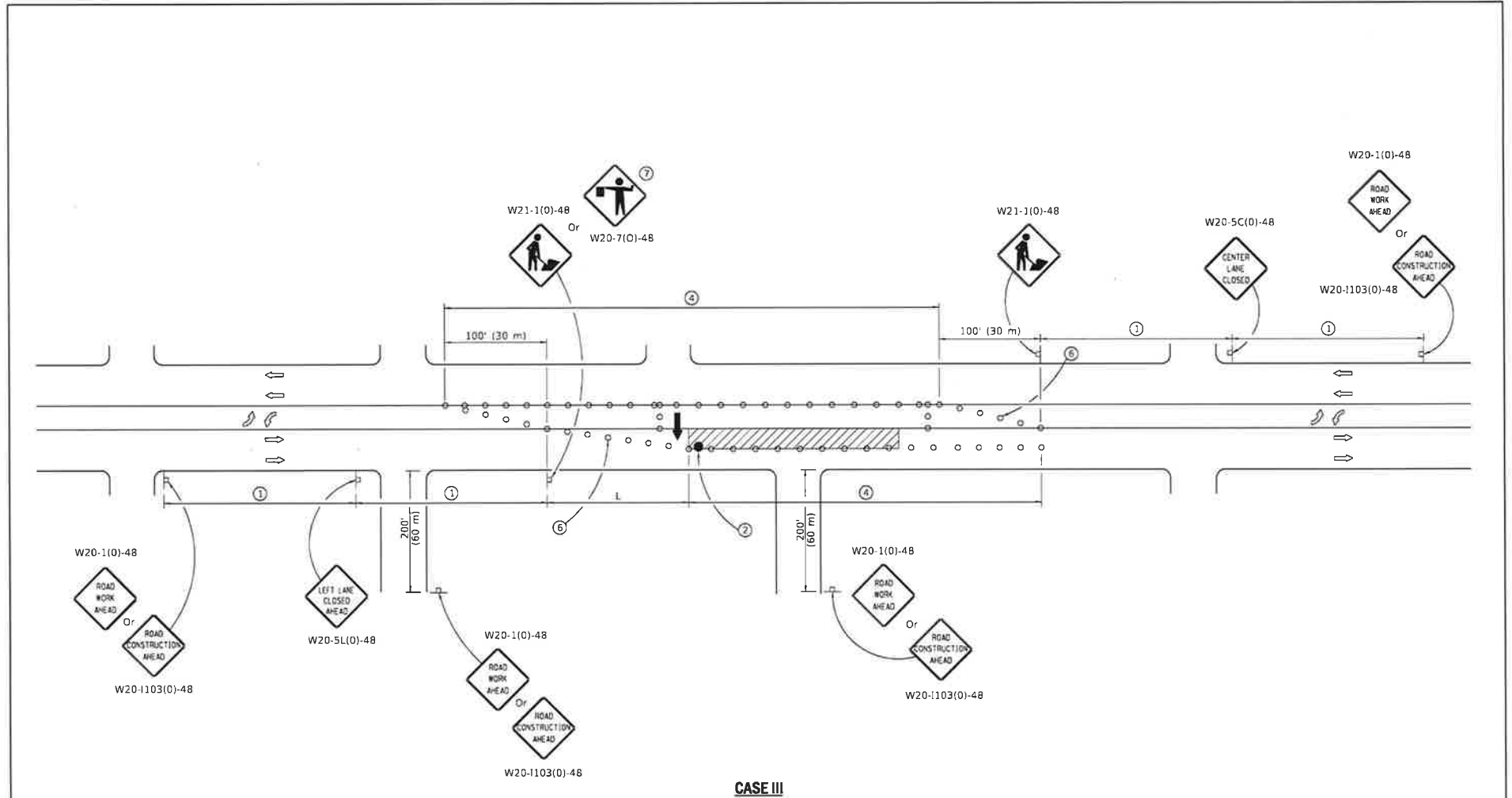

Illinois Department of Transportation

APPROVED: \_\_\_\_\_ January 3, 2019  
 ENGINEER OF SAFETY PROC AND ENGINEERING

APPROVED: \_\_\_\_\_ January 3, 2019  
 ENGINEER OF DESIGN AND ENVIRONMENT

FILED: JMS/MS

**URBAN LANE CLOSURE,  
 MULTILANE, 2W WITH  
 BIDIRECTIONAL LEFT TURN LANE**

(Sheet 3 of 4)

**STANDARD 701602-10**

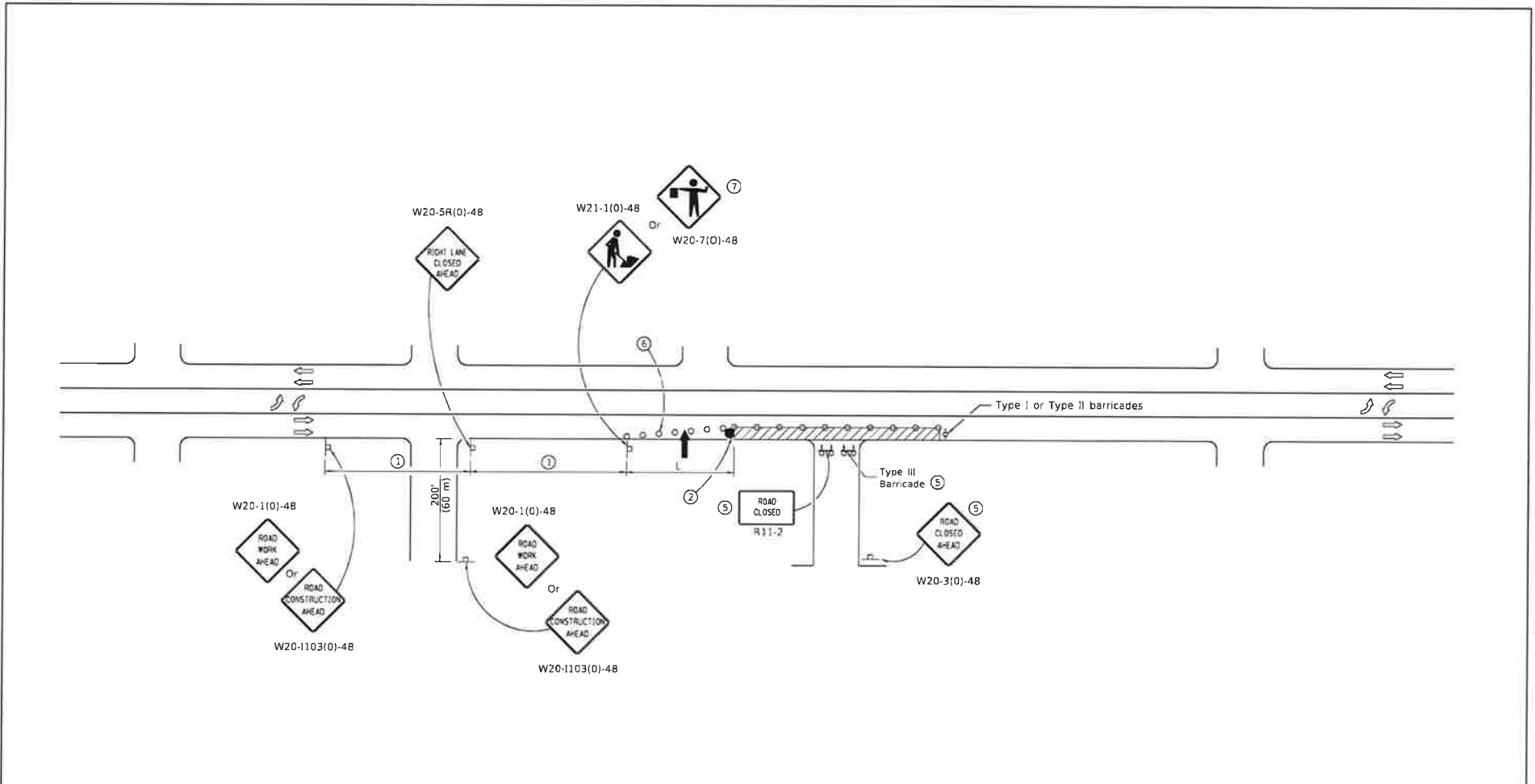

**CASE IV**

Illinois Department of Transportation

APPROVED: *[Signature]* January 1, 2019  
 ENGINEER OF SAFETY PROG. AND ENGINEERING

APPROVED: *[Signature]* January 1, 2019  
 ENGINEER OF DESIGN AND ENVIRONMENTAL

FILED: 01/01/19

**URBAN LANE CLOSURE,  
 MULTILANE, 2W WITH  
 BIDIRECTIONAL LEFT TURN LANE**

(Sheet 4 of 4)

**STANDARD 701602-10**

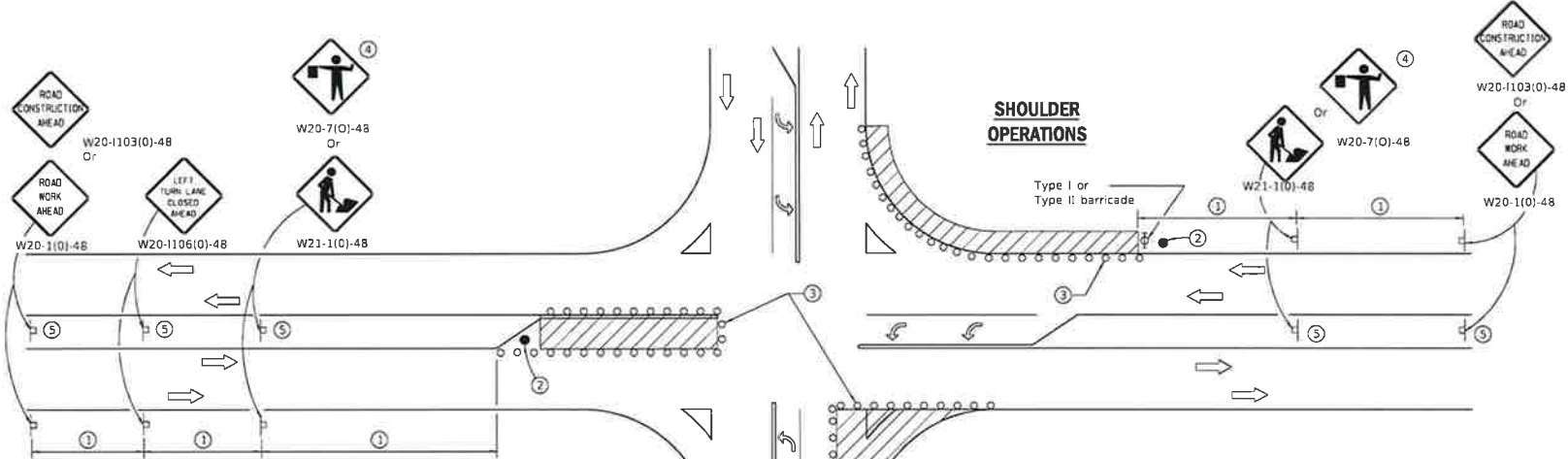

**LEFT TURN LANE OR CENTER MEDIAN OPERATIONS**

- ① Refer to SIGN SPACING TABLE for distance.
- ② Required for speed > 40 mph.
- ③ Cones at 25' (8 m) centers for 250' (75 m). Additional cones may be placed at 50' (15 m) centers. When drums or Type I or Type II barricades are used, the interval between devices may be doubled.
- ④ Use flagger sign only when flagger is present.
- ⑤ Omit this sign when median is less than 10' (3 m) or for bi-directional turn lanes.
- ⑥ Cones, drums or barricades at 20' (6 m) centers in taper.
- ⑦ Advanced arrow board required for speeds > 45 mph.
- ⑧ Three Type II barricades, drums or vertical barricades at 50' (15 m) centers.

**SYMBOLS**

- Work area
- Cone, drum or barricade
- Sign on portable or permanent support
- Arrow board
- Barricade or drum with flashing light
- Flagger with traffic control sign

SIGN SPACING	
Posted Speed	Sign Spacing
55	300' (150 m)
50-45	350' (100 m)
<45	200' (60 m)

**SHOULDER OPERATIONS**

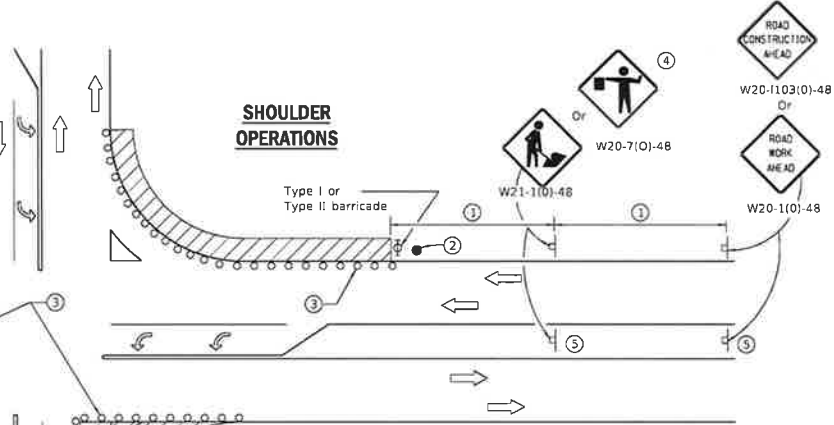

**CORNER ISLAND OPERATIONS**

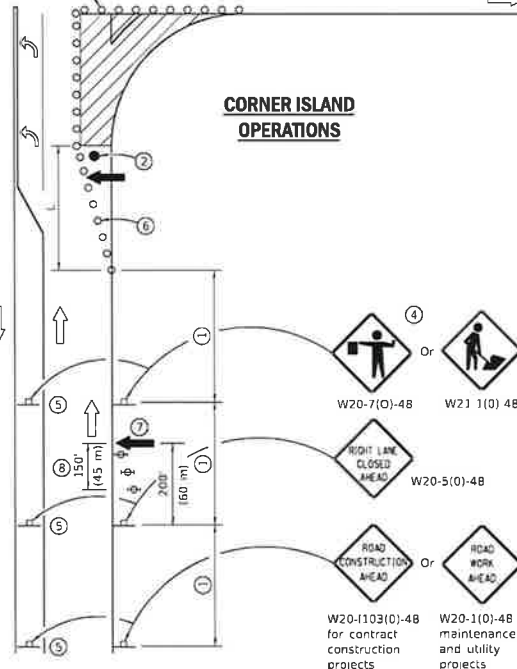

**GENERAL NOTES**

This Standard is used where at any time, day or night, any vehicle, equipment, workers or their activities encroach on the pavement during shoulder operations or where construction requires lane closures in an urban area.

Calculate L as follows:

SPEED LIMIT	FORMULAS	
	English	Metric
40 mph (70 km/h) or less:	$L = \frac{WS^2}{60}$	$L = \frac{WS^2}{150}$
45 mph (80 km/h) or greater:	$L = (W)(S)$	$L = 0.65(W)(S)$

W = Width of offset in feet (meters)

S = Normal posted speed mph (km/h).

All dimensions are in inches (millimeters) unless otherwise shown.

Illinois Department of Transportation

APPROVED: *[Signature]* April 1, 2016

ENGINEER OF SAFETY ENGINEERING

APPROVED: *[Signature]* April 1, 2016

ENGINEER OF DESIGN AND ENVIRONMENT

DATE	REVISIONS
4-1-16	Corrected sign number for LEFT TURN LANE CLOSED AHEAD
1-1-14	Added devices at arrow board upstream from taper
	Rev. workers sign number.

**URBAN LANE CLOSURE, MULTILANE INTERSECTION**

STANDARD 701701-10

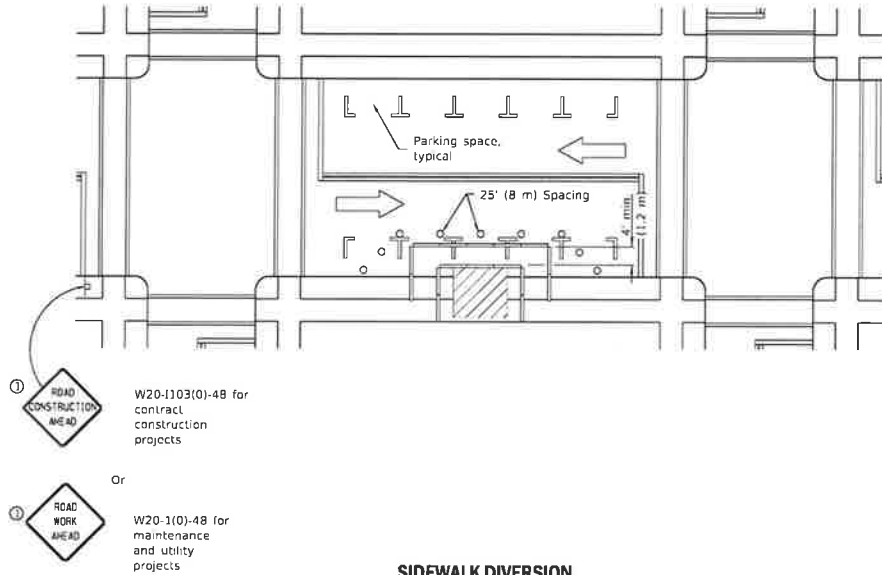

**SIDEWALK DIVERSION**

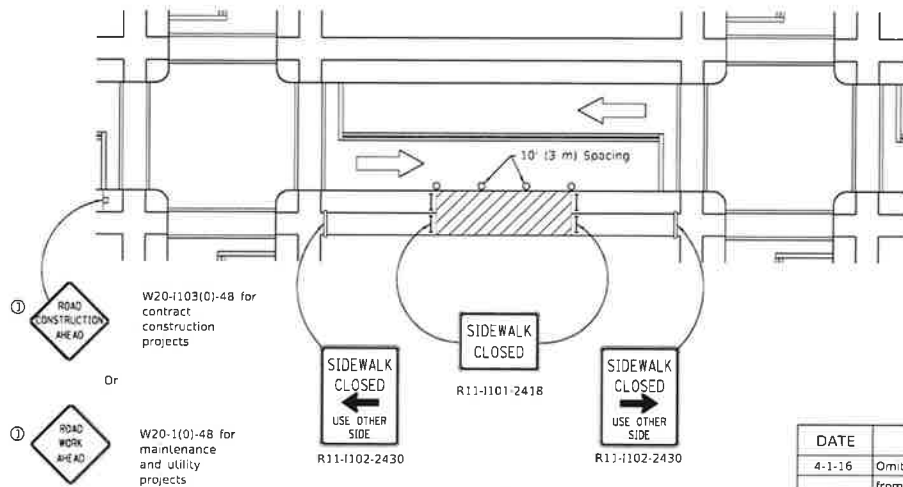

**SIDEWALK CLOSURE**

① Omit whenever duplicated by road work traffic control

**SYMBOLS**

- Work area
- Sign on portable or permanent support
- Barricade or drum
- Cone, drum or barricade
- Type III barricade
- Detectable pedestrian channelizing barricade

**GENERAL NOTES**

This Standard is used where, at any time, pedestrian traffic must be rerouted due to work being performed.

This Standard must be used in conjunction with other Traffic Control & Protection Standards when roadway traffic is affected.

Temporary facilities shall be detectable and accessible

The temporary pedestrian facilities shall be provided on the same side of the closed facilities whenever possible.

The SIDEWALK CLOSED / USE OTHER SIDE sign shall be placed at the nearest crosswalk or intersection to each end of the closure. Where the closure occurs at a corner, the signs shall be erected on the corners across the street from the closure. The SIDEWALK CLOSED signs shall be used at the ends of the actual closures.

Type III barricades and R11-2-4830 signs shall be positioned as shown in "ROAD CLOSED TO ALL TRAFFIC" detail on Standard 701901.

All dimensions are in inches (millimeters) unless otherwise shown.

Illinois Department of Transportation

ISSUED: April 1, 2018

REVISOR OF SAFETY FACILITIES

APPROVED: April 1, 2018

66 E. 11. 97

DATE	REVISIONS
4-1-16	Omitted orange safety fence from standard as this is covered in the std spec
1-1-12	Added SIDEWALK DIVERSION
	Modified appearance of plan view. Renamed Std.

**SIDEWALK, CORNER OR CROSSWALK CLOSURE**

(Sheet 1 of 2)

**STANDARD 701801-06**

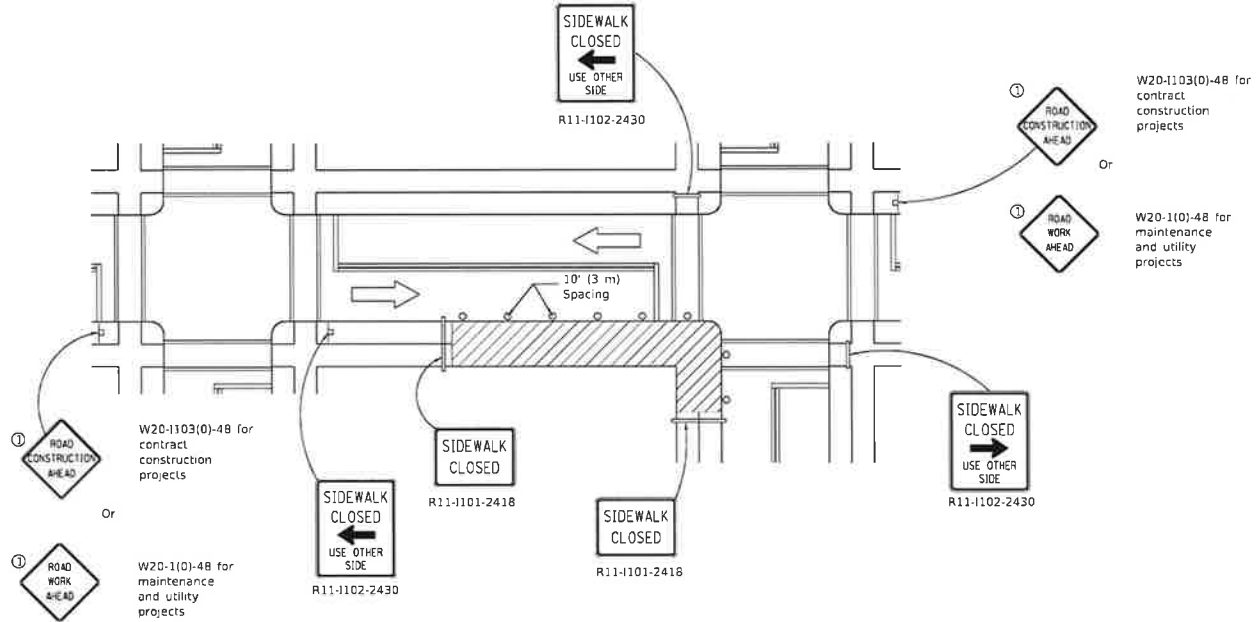

**CORNER CLOSURE**

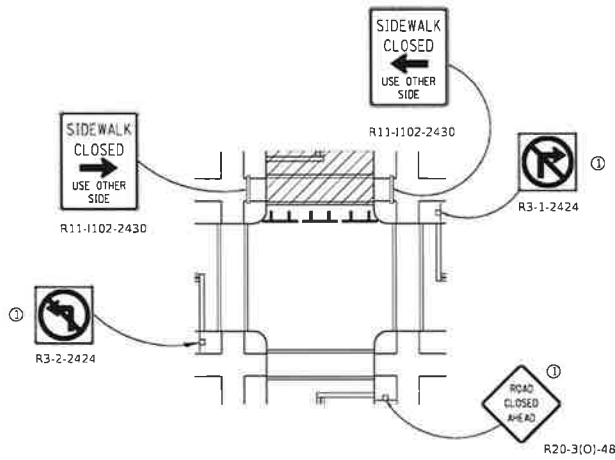

**CROSSWALK CLOSURE**

**SIDEWALK, CORNER OR CROSSWALK CLOSURE**  
 (Sheet 2 of 2)  
**STANDARD 701801-06**

Illinois Department of Transportation

PASS: IT 2016

APPROVED: *[Signature]* 2018

ENGINEER OF SAFETY ENGINEERING

APPROVED: *[Signature]* 2018

ENGINEER OF DESIGN AND ENVIRONMENT

DATE: 03/20/18

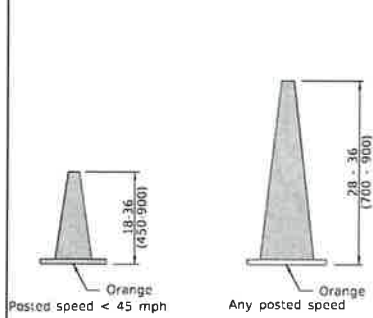

**DAYTIME USE**

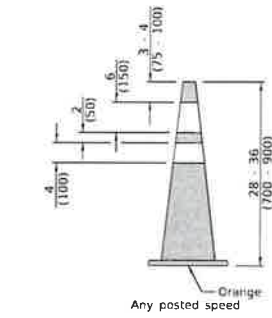

**CONES**

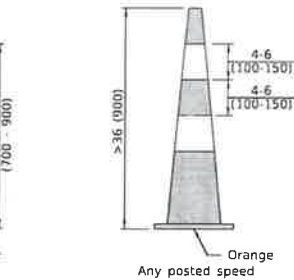

**DAY OR NIGHTTIME USE**

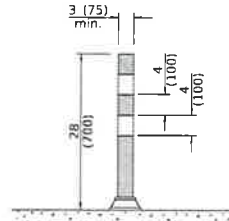

**TUBULAR MARKER**

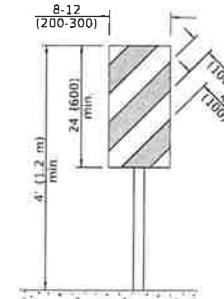

**VERTICAL PANEL  
POST MOUNTED**

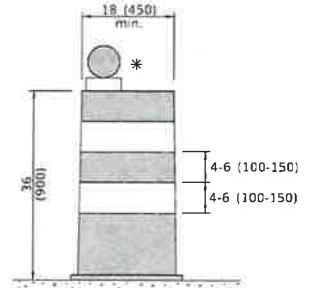

**DRUM**

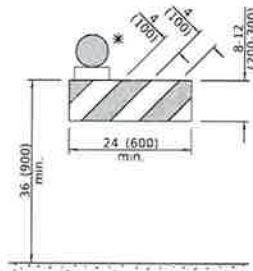

**TYPE I BARRICADE**

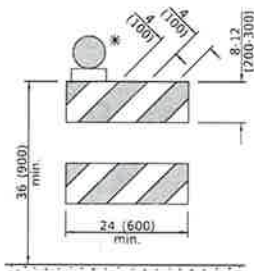

**TYPE II BARRICADE**

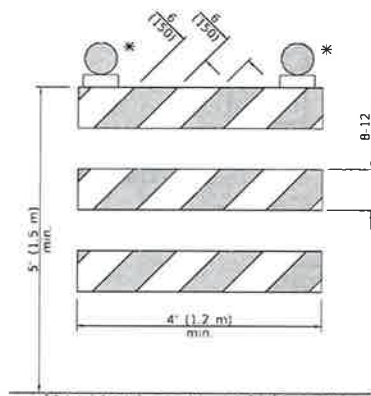

**TYPE III BARRICADE**

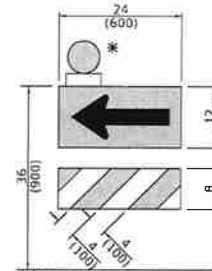

**DIRECTION INDICATOR  
BARRICADE**

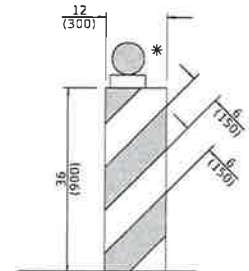

**VERTICAL BARRICADE**

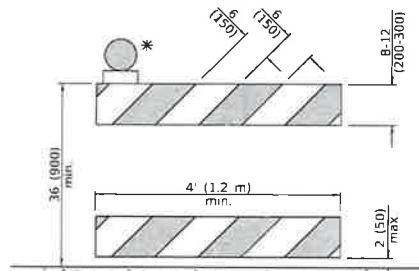

**DETECTABLE PEDESTRIAN  
CHANNELIZING BARRICADE**

\* Warning lights (if required)

**GENERAL NOTES**

All heights shown shall be measured above the pavement surface.

All dimensions are in inches (millimeters) unless otherwise shown.

Illinois Department of Transportation

APPROVED: [Signature] January 1, 2019  
 ENGINEER OF SAFETY TRAFFIC AND SIGNING

APPROVED: [Signature] January 3, 2019  
 ENGINEER OF SIGNS AND PAVEMENTS

ET 111 0885

DATE	REVISIONS
1-1-19	Revised cone usage and added cones >36" (900 mm) height.
1-1-18	Revised END WORK ZONE SPEED LIMIT sign from orange to white background.

**TRAFFIC CONTROL DEVICES**

(Sheet 1 of 3)

**STANDARD 701901-08**

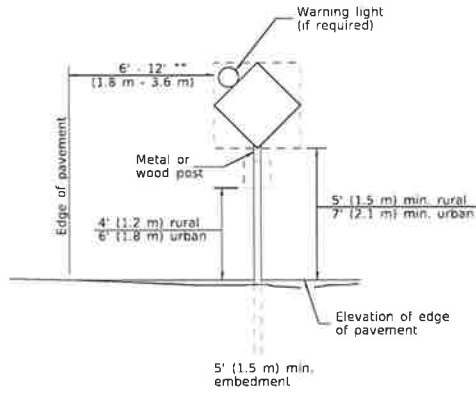

**POST MOUNTED SIGNS**

\*\* When curb or paved shoulder are present this dimension shall be 24 (600) to the face of curb or 5' (1.8 m) to the outside edge of the paved shoulder.

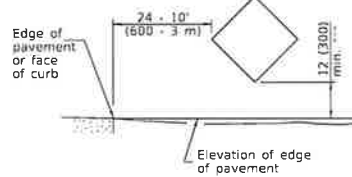

**SIGNS ON TEMPORARY SUPPORTS**

\*\*\* When work operations exceed four days, this dimension shall be 5 (1.5 m) min. If located behind other devices, the height shall be sufficient to be seen completely above the devices.

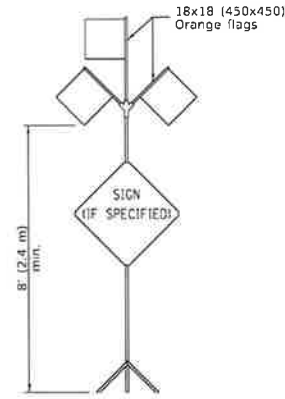

**HIGH LEVEL WARNING DEVICE**

ROAD CONSTRUCTION NEXT X MILES G20-1104(0)-6036	END CONSTRUCTION G20-1105(0)-6024
--	---

This signing is required for all projects 2 miles (3200 m) or more in length.  
ROAD CONSTRUCTION NEXT X MILES sign shall be placed 500' (150 m) in advance of project limits.  
END CONSTRUCTION sign shall be erected at the end of the job unless another job is within 2 miles (3200 m).  
Dual sign displays shall be utilized on multi-lane highways.

**WORK LIMIT SIGNING**

WORK ZONE	W21-1115(0)-3618
SPEED LIMIT <b>XX</b>	R2-1-3648
PHOTO ENFORCED	R10-1108p-3618 ****
\$\$\$ FINE MINIMUM	R2-1106p-3618

Sign assembly as shown on Standards or as allowed by District Operations.

END WORK ZONE SPEED LIMIT	G20-1103-6036
---------------------------------	---------------

This sign shall be used when the above sign assembly is used.

**HIGHWAY CONSTRUCTION  
SPEED ZONE SIGNS**

\*\*\*\* R10-1108p shall only be used along roadways under the jurisdiction of the State.



W12-1103-4848

**WIDTH RESTRICTION SIGN**

XX'-XX" width and X miles are variable.

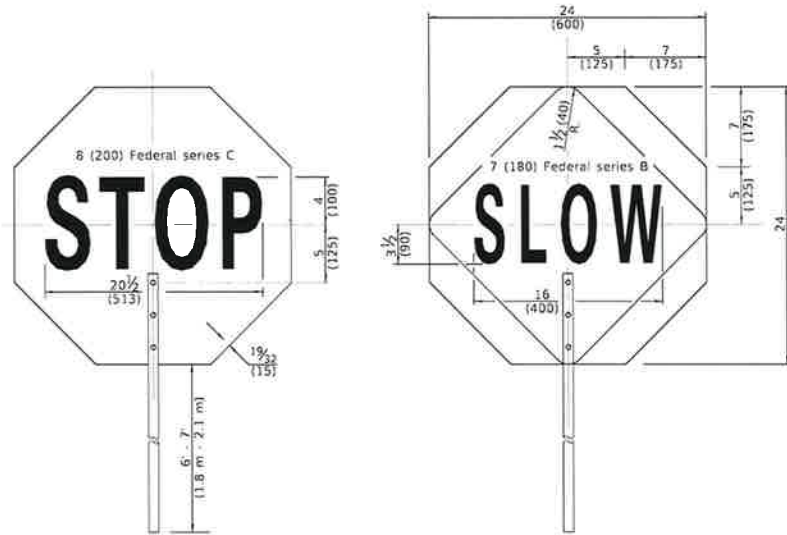

FRONT SIDE

REVERSE SIDE

**FLAGGER TRAFFIC CONTROL SIGN**

Illinois Department of Transportation

APPROVED: [Signature] DATE: 11/1/2019  
ENGINEER OF SAFETY PROG. AND ENGINEERING

APPROVED: [Signature] DATE: 11/1/2019  
ENGINEER OF DESIGN AND ENVIRONMENT

FILED: [Signature]

**TRAFFIC CONTROL  
DEVICES**

(Sheet 2 of 3)

**STANDARD 701901-08**

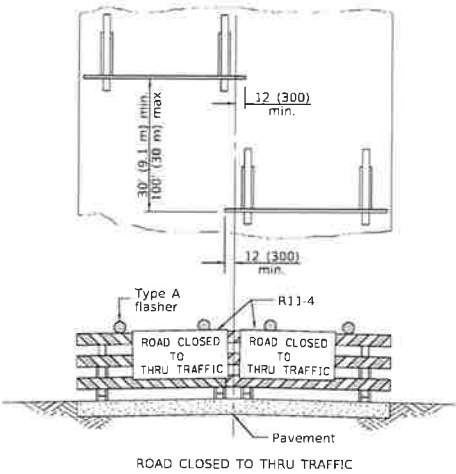
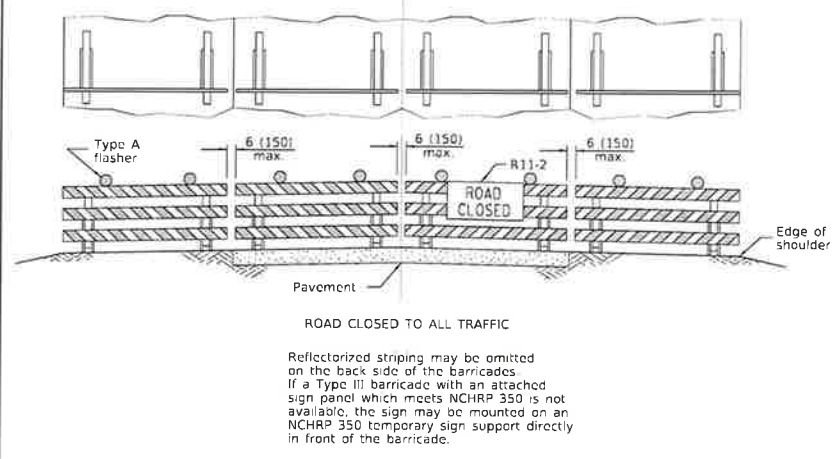
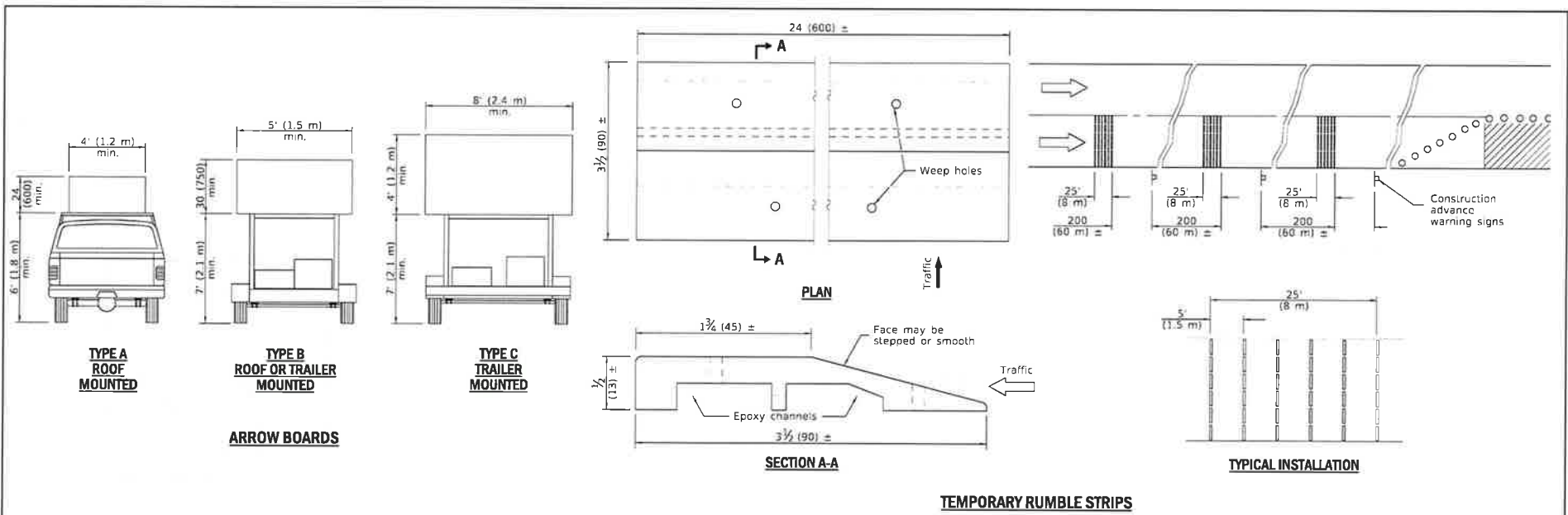

**TYPICAL APPLICATIONS OF TYPE III BARRICADES CLOSING A ROAD**

Reflectorized striping shall appear on both sides of the barricades. If a Type III barricade with an attached sign panel which meets NCHRP 350 is not available, the signs may be mounted on NCHRP 350 temporary sign supports directly in front of the barricade.

Illinois Department of Transportation

APPROVED: [Signature] 2019  
ENGINEER OF SAFETY PROG. AND ENGINEERING

APPROVED: [Signature] 2018  
ENGINEER OF DESIGN AND ENVIRONMENT

1111 02000

**TRAFFIC CONTROL DEVICES**

(Sheet 3 of 3)

**STANDARD 701901-08**

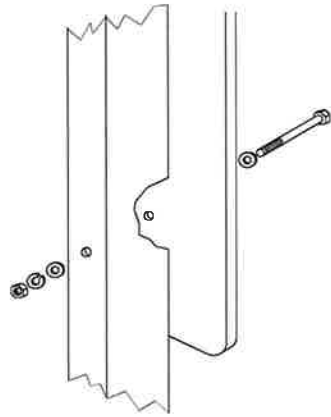

Sign panel 36 (900) wide or less

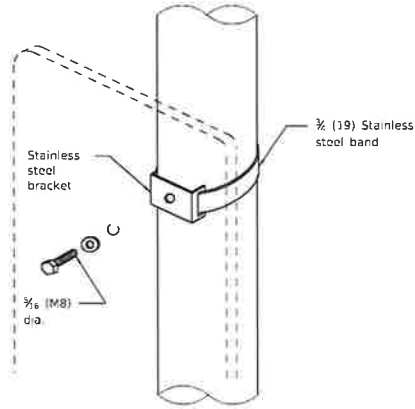

Sign panel 36 (900) wide or less

Section modulus (minimum)	Axis A	Axis B
Steel	0.050 in. <sup>3</sup> (819 mm <sup>3</sup> )	0.105 in. <sup>3</sup> (1720 mm <sup>3</sup> )
Aluminum	0.150 in. <sup>3</sup> (2458 mm <sup>3</sup> )	0.315 in. <sup>3</sup> (5162 mm <sup>3</sup> )

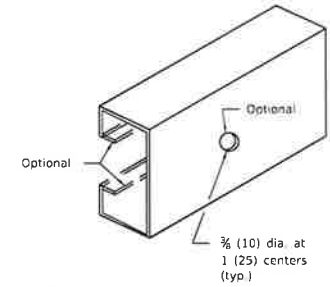
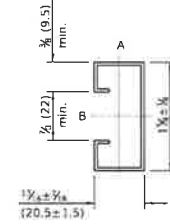

**SUPPORTING CHANNEL DETAILS**

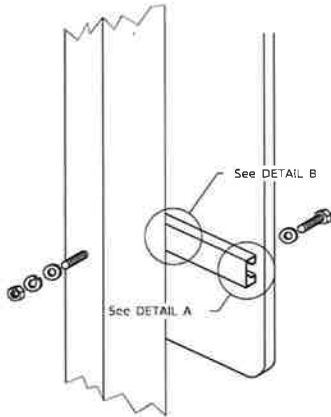

Sign panel over 36 (900) wide

**WOOD OR TELESCOPING STEEL POSTS**

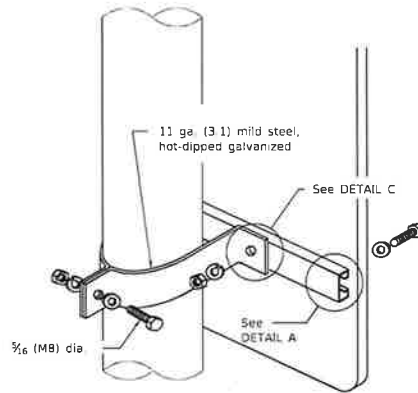

Sign panel over 36 (900) wide

**LIGHT OR SIGNAL STANDARDS**

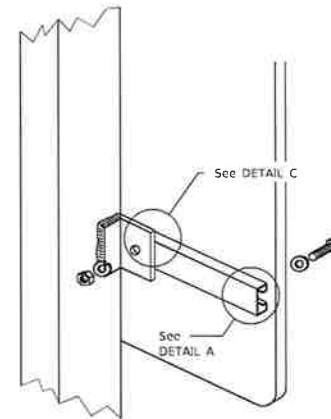

**BREAKAWAY STEEL TUBING POSTS**  
(All sign panel sizes)

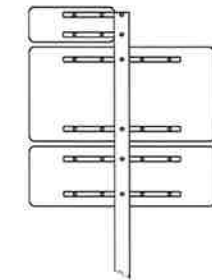

**ROUTE MARKER ASSEMBLY**

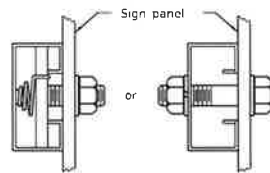

**DETAIL A**

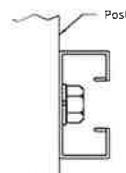

**DETAIL B**

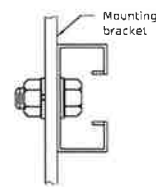

**DETAIL C**

All dimensions are in inches (millimeters) unless otherwise shown.

DATE	REVISIONS
1-1-09	Switched units to English (metric)
1-1-97	Renum Standard 2319-6.

**SIGN PANEL MOUNTING DETAILS**

STANDARD 720001-01

Illinois Department of Transportation  
 PASS/ID January 1, 2009  
 ENGINEER OF OPERATIONS  
 APPROVED January 1, 2009  
 REGISTERED PROFESSIONAL ENGINEER

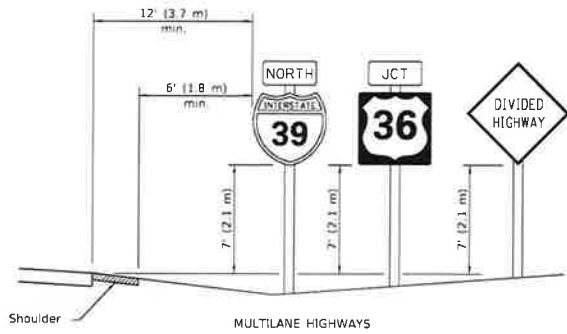

MULTILANE HIGHWAYS

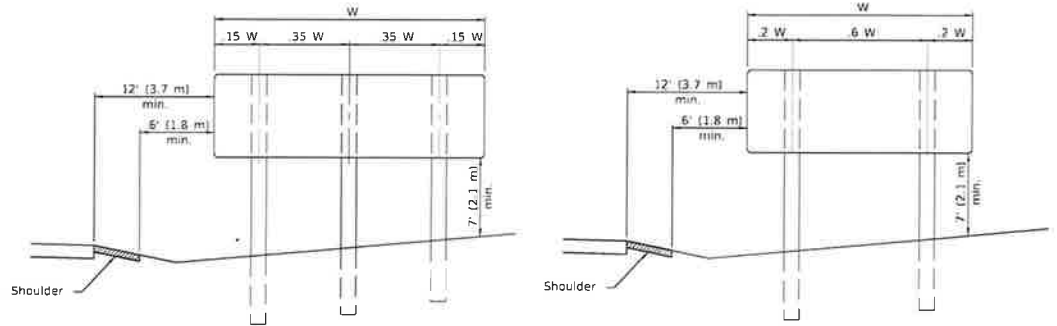

POST SPACING FOR NON-FREEWAY SIGN PANELS

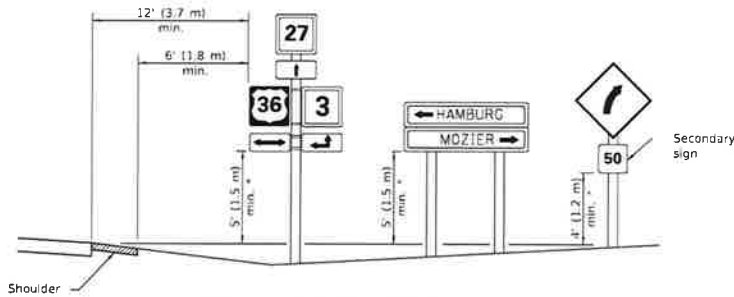

\* In any area where parking is likely to occur or where there are obstructions to view or where signs are located over sidewalks, the height shall be at least 7' (2.1 m).

TWO LANE RURAL HIGHWAYS

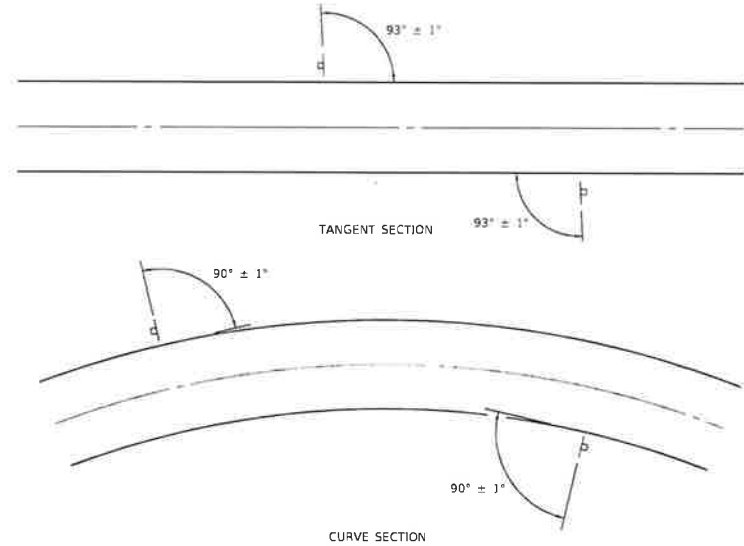

GROUND MOUNT SIGN POSITIONING

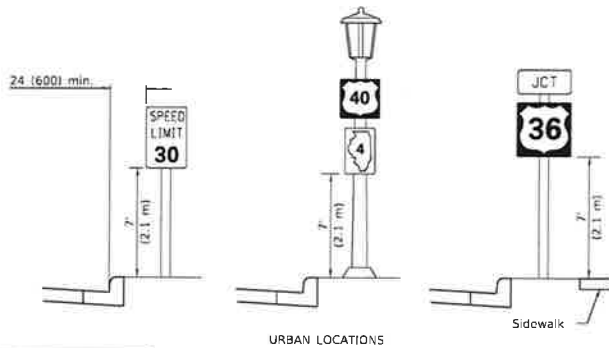

URBAN LOCATIONS

**TYPICAL INSTALLATIONS**

Signs in any area shall be erected to a uniform height above the edge of the pavement.

All dimensions are in inches (millimeters) unless otherwise shown.

Illinois Department of Transportation

PASSED January 1, 2014

DESIGNED BY: [Signature]

APPROVED BY: [Signature]

46 (1) 01050

DATE	REVISIONS
1-1-14	Added shoulders and slopes. Changed sign distances from roadway and shoulder.
1-1-12	Rev. sign elev. for multilane hwy's. Revised sign elev. and dist. to curb for rural loc.

**SIGN PANEL ERECTION DETAILS**

STANDARD 720006-04

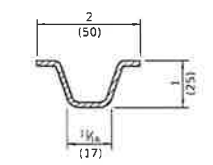
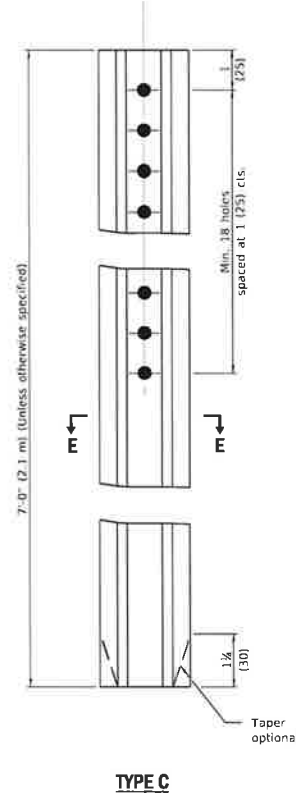
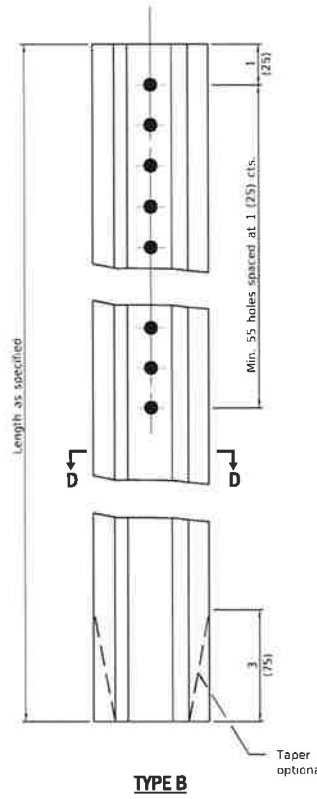
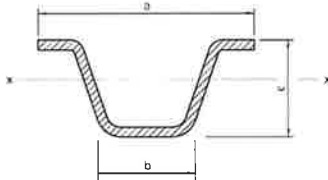
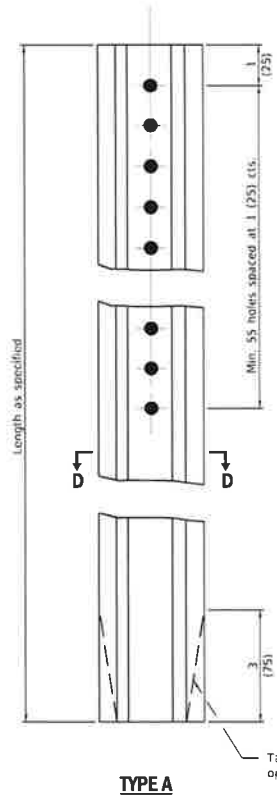

Steel - 1.12 lbs./ft. (1.67 kg/m)

		a	b	c	S <sub>x-x</sub> in. <sup>2</sup> (mm <sup>2</sup> )	lbs./ft. (kg/m)
TYPE A	Steel	3/8 (7.6)	1/4 (3.2)	1/8 (3.2)	0.223 (3.504)	2.08 (2.98)
	Aluminum	3/8 (9.5)	1/4 (4.3)	1/8 (4.6)	0.231 (3.28)	0.90 (1.34)
TYPE B	Steel	3/8 (9.5)	1/4 (3.2)	1/8 (3.2)	0.241 (3.588)	3.00 (4.46)
	Aluminum	4/8 (11.8)	2/8 (5.7)	2/8 (6.0)	0.888 (14.52)	1.30 (1.93)

**GENERAL NOTES**

Dimensions shown for cross sections are minimum.

All holes are 3/8 (10).

S<sub>x-x</sub> is the minimum section modulus about the x-x axis of the post as shown. For posts in which holes are punched or drilled for more than half their length, S<sub>x-x</sub> shall be computed for the net section.

All dimensions are in inches (millimeters) unless otherwise shown.

Illinois Department of Transportation

PASSED January 1, 2009

ENGINEER OF POLICY AND PROCEDURES

APPROVED January 31, 2009

ILLINOIS DEPARTMENT OF TRANSPORTATION

DATE	REVISIONS
1-1-09	Switched units to English (metric)
1-1-97	Renum. Standard 2350-4.

**METAL POSTS FOR SIGNS, MARKERS & DELINEATORS**

STANDARD 720011-01

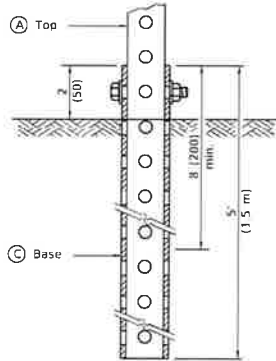

**GROUND MOUNT DETAIL**

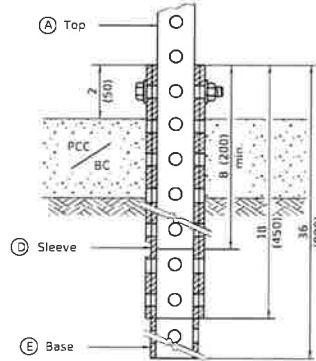

**PAVEMENT MOUNT DETAIL**

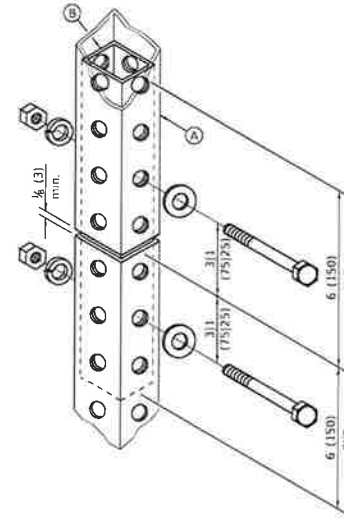

**SPLICE DETAIL**

A	2 x 2 x var. (51 x 51 var.)
B	1 3/4 x 1 3/4 x 12 (44 x 44 x 300)
C	2 1/4 x 2 1/4 x 60 (57 x 57 x 1500)
D	2 1/2 x 2 1/2 x 18 (64 x 64 x 450)
E	2 1/2 x 2 1/4 x 36 (57 x 57 x 900)

**GENERAL NOTES**

All bolts 3/8 (M10) hex head zinc or cadmium plated.

All dimensions are in inches (millimeters) unless otherwise shown.

Illinois Department of Transportation

PASSED January 1, 2009

ENGINEER OF OPERATIONS

APPROVED

6011 0100

DATE	REVISIONS
1-1-09	Switched units to English (metric)
1-1-07	New Standard Used to be part of Standard 720006

**TELESCOPING STEEL SIGN SUPPORT**

**STANDARD 728001-01**

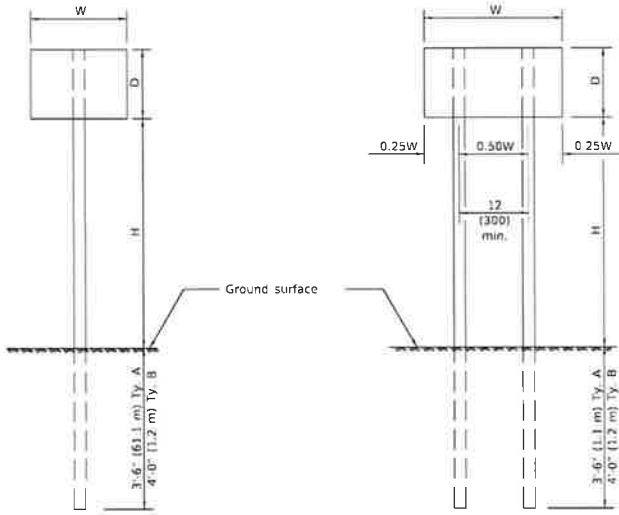

**ONE POST INSTALLATION**

**TWO POST INSTALLATION**

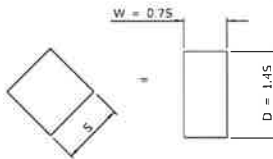

For diamond shaped sign with side S as shown, use required post size for a sign with W = 0.75 and D = 1.45.

SIGN DEPTH (D)	H	NO. AND TYPE OF POST FOR SIGN WIDTH (W)				
		12 (300)	18 (450)	24 (600)	30 (750)	36 (900)
18 (450)	5'-0" (1.5 m)	A	A	A	A	A
	5'-6" (1.7 m)	A	A	A	A	A
	6'-0" (1.8 m)	A	A	A	A	B
	6'-6" (2.0 m)	A	A	A	A	B
	7'-0" (2.1 m)	A	A	A	A	B
	7'-6" (2.3 m)	A	A	A	A	B
	8'-0" (2.4 m)	A	A	A	A	B
	8'-6" (2.6 m)	A	A	A	B	B
	9'-0" (2.7 m)	A	A	A	B	B
24 (600)	5'-0" (1.5 m)	A	A	A	A	B
	5'-6" (1.7 m)	A	A	A	A	B
	6'-0" (1.8 m)	A	A	A	B	B
	6'-6" (2.0 m)	A	A	A	B	B
	7'-0" (2.1 m)	A	A	A	B	B
	7'-6" (2.3 m)	A	A	A	B	B
	8'-0" (2.4 m)	A	A	A	B	2A
	8'-6" (2.6 m)	A	A	B	B	2A
	9'-0" (2.7 m)	A	A	B	B	2A
30 (750)	5'-0" (1.5 m)	A	A	A	B	B
	5'-6" (1.7 m)	A	A	A	B	2A
	6'-0" (1.8 m)	A	A	A	B	2A
	6'-6" (2.0 m)	A	A	A	B	2A
	7'-0" (2.1 m)	A	A	B	B	2A
	7'-6" (2.3 m)	A	A	B	B	2A
	8'-0" (2.4 m)	A	A	B	B	2A
	8'-6" (2.6 m)	A	A	B	2A	2A
	9'-0" (2.7 m)	A	A	B	2A	2A
36 (900)	5'-0" (1.5 m)	A	A	B	B	2A
	5'-6" (1.7 m)	A	A	B	B	2A
	6'-0" (1.8 m)	A	A	B	B	2A
	6'-6" (2.0 m)	A	A	B	2A	2A
	7'-0" (2.1 m)	A	A	B	2A	2A
	7'-6" (2.3 m)	A	A	B	2A	2A
	8'-0" (2.4 m)	A	B	B	2A	2A
	8'-6" (2.6 m)	A	B	B	2A	2B
	9'-0" (2.7 m)	A	B	2A	2A	2B
4'-0" (1.2 m)	5'-0" (1.5 m)	A	A	B	2A	2A
	5'-6" (1.7 m)	A	B	B	2A	2A
	6'-0" (1.8 m)	A	B	B	2A	2A
	6'-6" (2.0 m)	A	B	2A	2A	2B
	7'-0" (2.1 m)	A	B	2A	2A	2B
	7'-6" (2.3 m)	A	B	2A	2B	2B
	8'-0" (2.4 m)	A	B	2A	2B	2B
	8'-6" (2.6 m)	B	B	2B	2B	2B
	9'-0" (2.7 m)	B	2A	2B	2B	2B

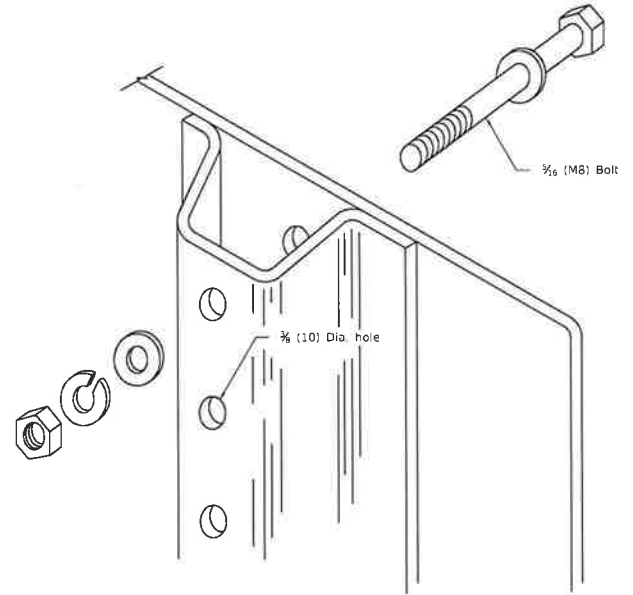

**DETAIL OF MOUNTING SIGN TO POST**

NOTE: Minimum of 2 bolts per post required.

**GENERAL NOTES**

DESIGN: Current AASHTO Standard Specifications for Structural Supports for Highway Signs, Luminaires and Traffic Signals.

LOADING: for 60 mph (95 km/h) wind velocity with 30% gust factor, normal to sign.

SOIL PRESSURE: Minimum allowable soil pressure 1.25 tsf (120 kPa).

See Standard 720011 for details of Types A and B posts.

All dimensions are in inches (millimeters) unless otherwise shown.

DATE	REVISIONS
1-1-09	Switched units to English (metric).
1-1-97	Revised Standard 2363-2.

**APPLICATIONS OF TYPES A & B METAL POSTS (FOR SIGNS & MARKERS)**

**STANDARD 729001-01**

Illinois Department of Transportation

PASS # \_\_\_\_\_ January 1, 2009

ENGINEER OF POLICY AND PROCEDURES

APPROVED \_\_\_\_\_ January 1, 2009

ENGINEER OF DESIGN AND ENVIRONMENT

6 1/8" x 11" (152 mm x 279 mm)

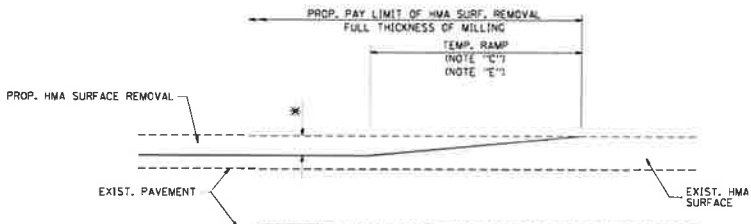

MILLED TEMPORARY RAMP  
(FOR BUTT JOINT AND HMA TAPER SEE DETAIL BELOW)

**OPTION 1**

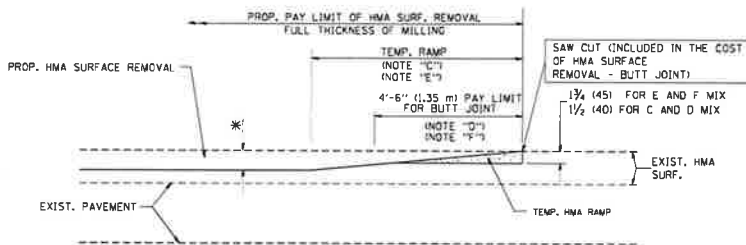

HMA CONSTRUCTED TEMPORARY RAMP  
(FOR BUTT JOINT AND HMA TAPER SEE DETAIL BELOW)

**OPTION 2**

**TYPICAL TEMPORARY RAMP**

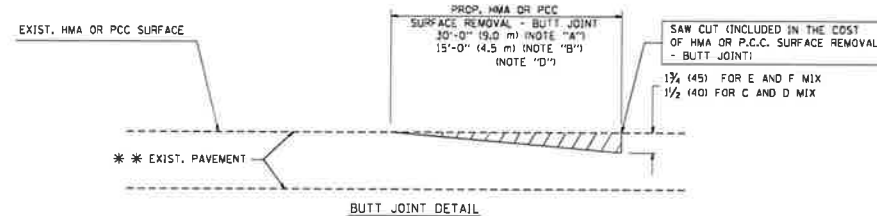

BUTT JOINT DETAIL

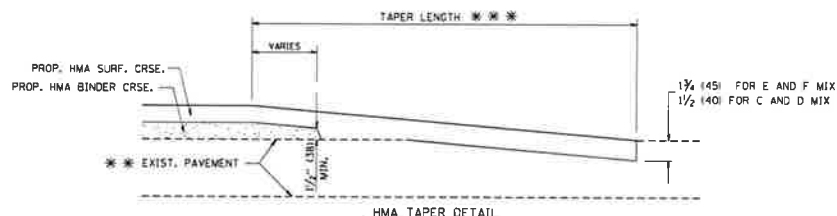

HMA TAPER DETAIL

**TYPICAL BUTT JOINT AND HMA TAPER FOR RESURFACING ONLY**

\* \* PC CONCRETE, HMA OR HMA RESURFACED PAVEMENT.

**NOTES**

- A: MAINLINE ROADWAYS AND MAJOR SIDE ROADS.
- B: MINOR SIDE ROADS.
- C: THE TEMP. RAMP SHALL BE CONSTRUCTED IMMEDIATELY UPON REMOVAL OF THE EXISTING HMA SURFACE.
- D: THE BUTT JOINT SHALL BE CONSTRUCTED IMMEDIATELY PRIOR TO PLACING THE PROPOSED HMA COURSES.
- E: TAPER THE TEMP. RAMP AT A RATE OF 3'-0" (900 mm) PER 1 INCH (25 mm) OF MILLING THICKNESS.
- F: INSTALLATION AND REMOVAL OF THE 4'-6" (1.35 m) TEMP. RAMP IS INCLUDED IN COST OF HMA SURFACE REMOVAL - BUTT JOINT.
- G: SEE ARTICLE 406.08 AND 406.14 OF THE STANDARD SPECIFICATIONS FOR "HMA AND/OR PCC SURFACE REMOVAL, BUTT JOINT".
- \* SEE TYPICAL SECTIONS FOR MILLING THICKNESS.
- \* \* \* 20'-0" (6.1 m) PER 1 (25) RESURFACING (NOTE "A")
- 10'-0" (3.0 m) PER 1 (25) RESURFACING (NOTE "B")

**BASIS OF PAYMENT:**

THE BUTT JOINT WILL BE PAID FOR AT THE CONTRACT UNIT PRICE PER SQUARE YARD (SQUARE METER) FOR "HOT-MIX ASPHALT SURFACE REMOVAL - BUTT JOINT" OR FOR "PORTLAND CEMENT CONCRETE SURFACE REMOVAL - BUTT JOINT".

ALL DIMENSIONS ARE IN INCHES (MILLIMETERS) UNLESS OTHERWISE SHOWN.

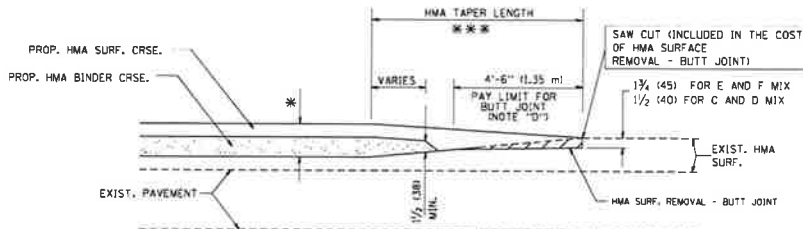

BUTT JOINT AND HMA TAPER

**TYPICAL BUTT JOINT AND HMA TAPER FOR MILLING AND RESURFACING**

FILE NAME: W:\miller\27234\27234.dgn	USER NAME: j.guyton	DESIGNED: M. DE FONG	REVISED: R. SHAW 10-25-94
		DRAWN:	REVISED: A. ABBAS 03-21-97
	PLOT SCALE: 1/8"=1'-0"	CHECKED:	REVISED: M. SANCHEZ 04-08-01
	PLOT DATE: 1/14/2009	DATE: 06-13-90	REVISED: R. BORO 01-01-07

STATE OF ILLINOIS  
DEPARTMENT OF TRANSPORTATION

BUTT JOINT AND  
HMA TAPER DETAILS

SCALE: NONE SHEET NO. 1 OF 1 SHEETS STA. TO STA.

SECTION	COUNTY	TOTAL SHEETS
B0400-05 B032		
CONTRACT NO.		
FEB. ROAD DIST. NO. 1 ILLINOIS, I.D. PROJECT		

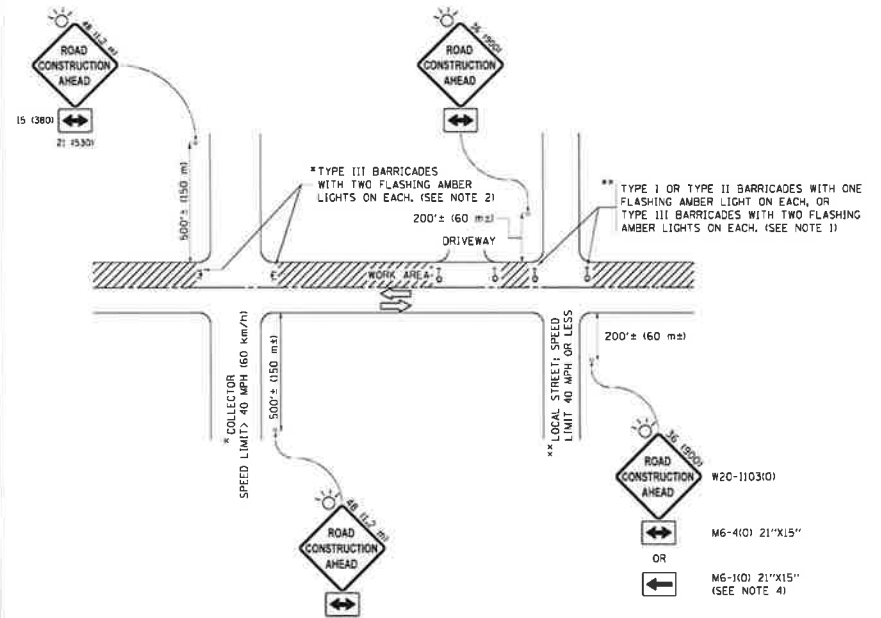

**NOTES:**

1. SIDE ROAD WITH A SPEED LIMIT OF 40 MPH (60 km/h) OR LESS AS SHOWN ON THE DRAWING AND AS DIRECTED BY THE ENGINEER:
  - a) ONE "ROAD CONSTRUCTION AHEAD" SIGN 36 x 36 (900x900) WITH A FLASHER MOUNTED ON IT APPROXIMATELY 200' (60 m) IN ADVANCE OF THE MAIN ROUTE.
  - b) THE CLOSED PORTION OF THE MAIN ROUTE SHALL BE PROTECTED BY BLOCKING WITH TYPE I, TYPE II OR TYPE III BARRICADES, 1/3 OF THE CROSS SECTION OF THE CLOSED PORTION.
2. SIDE ROAD WITH A SPEED LIMIT GREATER THAN 40 MPH (60 km/h) AS SHOWN ON THE DRAWING AND AS DIRECTED BY THE ENGINEER:
  - a) ONE "ROAD CONSTRUCTION AHEAD" SIGN 48 x 48 (1.2 m x 1.2 m) WITH A FLASHER MOUNTED ON IT APPROXIMATELY 500' (150 m) IN ADVANCE OF THE MAIN ROUTE.
  - b) THE CLOSED PORTION OF THE MAIN ROUTE SHALL BE PROTECTED BY BLOCKING WITH TYPE III BARRICADES, 1/2 OF THE CROSS SECTION OF THE CLOSED PORTION.
3. CONES MAY BE SUBSTITUTED FOR BARRICADES OR DRUMS AT HALF THE SPACING DURING DAY OPERATIONS. CONES SHALL BE A MINIMUM OF 28 (710) IN HEIGHT.
4. WHEN THE SIDE ROAD LIES BETWEEN THE BEGINNING OF THE MAINLINE SIGNING AND THE WORK ZONE, A SINGLE HEADED ARROW (M6-1) SHALL BE USED IN LIEU OF THE DOUBLE HEADED ARROW (M6-4).
5. WHEN WORK IS BEING PERFORMED ON A SIDE ROAD OR DRIVEWAY, FOLLOW THE APPLICABLE STANDARD(S), THE DIRECTIONAL ARROW (M6-1 OR M6-4) SHALL BE COVERED OR REMOVED WHEN NO LONGER CONSISTENT WITH THE TRAFFIC CONTROL SET-UP.
6. ADVANCE WARNING SIGNS ARE TO BE OMITTED ON DRIVEWAYS UNLESS OTHERWISE SPECIFIED IN THE PLANS OR BY THE ENGINEER.
7. THE TRAFFIC CONTROL AND PROTECTION FOR SIDE ROADS, INTERSECTIONS, AND DRIVEWAYS SHALL BE INCLUDED IN THE COST OF SPECIFIED TRAFFIC CONTROL STANDARDS OR ITEMS.

All dimensions are in inches (millimeters) unless otherwise shown.

DESIGNED - L.J.A.	REVISOR - A. HOUSEH 10-15-98
CHECKED - A. SCHUTZEL 07-01-13	REVISOR - T. RAMMACHER 01-06-00
DATE - 06-89	REVISOR - A. SCHUTZEL 09-15-16

**STATE OF ILLINOIS  
DEPARTMENT OF TRANSPORTATION**

**TRAFFIC CONTROL AND PROTECTION FOR  
SIDE ROADS, INTERSECTIONS, AND DRIVEWAYS**

SCALE: NONE SHEET 1 OF 1 SHEETS STA. TO STA.

SECTION	COUNTY	TOTAL SHEETS
TC-10		
CONTRACT NO.		
ILLINOIS FED. AID PROJECT		



**APPENDIX C**

**ORDINANCE 3733 AMENDING THE REQUIREMENTS OF  
BIDDERS FOR CONSTRUCTION PROJECTS**



**Ordinance No. 3733****AN ORDINANCE OF THE VILLAGE OF VILLA PARK, DUPAGE COUNTY, ILLINOIS AMENDING THE REQUIREMENTS OF BIDDERS FOR CONSTRUCTION PROJECTS**

**WHEREAS**, the Village of Villa Park (the “*Village*”) is a duly organized and validly existing non home-rule municipality created in accordance with the Constitution of the State of Illinois of 1970 and the laws of the State; and,

**WHEREAS**, section 8-9-1 of the Illinois Municipal Code (65 ILCS 5/8-9-2) allows the Village to require competitive bidding after advertising for bids in the manner prescribed by ordinance; and,

**WHEREAS**, the President and Board of Trustees desire to adopt purchasing procedures to provide for additional requirements of bidders for construction projects to have active apprenticeship and training programs approved and registered with the United States Department of Labor’s Bureau of Apprenticeship and Training and to have bidders show three similar projects they constructed within the last five years.

**NOW, THEREFORE, BE IT ORDAINED** by the President and Board of Trustees of the Village of Villa Park, DuPage County, Illinois, as follows:

**Section 1.** That Section 2-219 of the Villa Park Municipal Code, as amended, be and is hereby amended by placing the existing text as subsection A. and adding a new subsection B. to read as follows:

“B. A responsible bidder for the construction of public works projects shall meet and submit evidence of compliance with the following requirements:

- (1) All applicable laws prerequisite to doing business in the State of Illinois,
- (2) A federal employer tax identification number or social security number,
- (3) Provision of Section 2000(e) of Chapter 21, Title 42 of the United States Code and Federal Executive Order No. 11246 as amended by Executive Order No. 11375 (known as the Equal Opportunity Employer provisions),
- (4) Certificates of insurance indicating the following coverage’s: general liability, worker’s compensation, completed operations, automobile, hazardous occupation and product liability
- (5) Compliance with all provisions of the Illinois Prevailing Wage Act, including wages, medical and hospitalization insurance and retirement for those trades covered in the Act,
- (6) The bidder and all bidder’s sub-contractors must participate in active apprenticeship and training programs approved and registered with the United States Department of Labor’s Bureau of Apprenticeship and Training for each of the trades of work contemplated under the proposed contract,
- (7) All contractors and sub-contractors are required to file certified payrolls as specified in Illinois Pubic Act 94-0515, and follow all provisions of the Employee Classification Act (820 ILCS 185/1 et seq.), and

(8) All bidders must provide three (3) projects of a similar nature constructed in the immediate past five (5) years with the name, address and telephone number of the contact person having knowledge of the project along with three (3) references (name, address, and telephone number) with knowledge of the integrity and business practices of the bidder.”

**Section 2.** This Ordinance shall be in full force and effect upon its passage, approval, and publication as provided by law.

Passed this 11 day of February, 2013.

AYES: ALL

NAYS: Aiello Bulthuis

ABSENT: \_\_\_\_\_

Approved this 11 day of February, 2013.

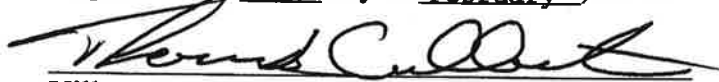

Village President

Attest:

  
Village Clerk

Published in pamphlet form:

2-11, 2013

**APPENDIX D**

**IRMA CONTRACTUAL INSURANCE GUIDELINES**



## IRMA CONTRACTUAL INSURANCE GUIDELINES

### I. INSURANCE REQUIREMENTS

Contractor shall procure and maintain, for the duration of the contract, insurance against claims for injuries to persons or damages to property, which may arise from or in connection with the performance of the work hereunder by the Contractor, his agents, representatives, employees or subcontractors.

#### MINIMUM SCOPE OF INSURANCE

Coverage shall be at least as broad as:

- A. Insurance Services Office Commercial General Liability occurrence form CG 0001 with the member named as additional insured, on a form at least as broad as the attached sample endorsement including ISO Additional Insured Endorsement CG 2010 (Exhibit A), CG 2026 (Exhibit B).

#### **CG2037 - Completed Operations – (Exhibit C)**

**Required if box is checked**  ; and

- B. Owners and Contractors Protective Liability (OCP) policy with the member as insured

**Required if box is checked**  ; and

- C. Insurance Service Office Business Auto Liability coverage form number CA 0001, Symbol 01 "Any Auto."

- D. Workers' Compensation as required by the Workers' Compensation Act of the State of Illinois and Employers' Liability insurance.

**Coverage required for employee exposure to lead, if box is checked**

- E. Builder Risk Property Coverage with member as loss payee

**Required if box is checked** .

- F. Environmental Impairment/Pollution Liability Coverage for pollution incidents as a result of a claim for bodily injury, property damage or remediation costs from an incident at, on or migrating beyond the contracted work site. Coverage shall be extended to Non-Owned Disposal sites resulting from a pollution incident at, on or mitigating beyond the site; and also provide coverage for incidents occurring during transportation of pollutants.

**Required if box is checked** .

#### MINIMUM LIMITS OF INSURANCE

Contractor shall maintain limits no less than the following, **if required under above scope**:

- A. Commercial General Liability: \$1,000,000 combined single limit per occurrence for bodily injury, and property damage and \$1,000,000 per occurrence for personal injury. The general aggregate shall be twice the required occurrence limit. Minimum General Aggregate shall be no less than \$2,000,000 or a project/contract

specific aggregate of \$1,000,000.

- B. Owners and Contractors Protective Liability (OCP): \$1,000,000 combined single limit per occurrence for bodily injury and property damage.
- C. Business Automobile Liability: \$1,000,000 combined single limit per accident for bodily injury and property damage.
- D. Workers' Compensation and Employers' Liability: Workers' Compensation coverage with statutory limits and Employers' Liability limits of \$500,000 per accident.
- E. Builder's Risk: Shall insure against "All Risk" of physical damage, including water damage (flood and hydrostatic pressure not excluded), on a completed replacement cost basis.
- F. Environmental Impairment/Pollution Liability: \$1,000,000 combined single limit per occurrence for bodily injury, property damage and remediation costs.

### **DEDUCTIBLES AND SELF-INSURED RETENTIONS**

Any deductibles or self-insured retentions must be declared to and approved by the member. At the option of the member, either: the insurer shall reduce or eliminate such deductibles or self-insured retentions as respects the member, its officials, employees, agents and volunteers; or the Contractor shall procure a bond guaranteeing payment of losses and related investigation, claim administration and defense expenses.

### **OTHER INSURANCE PROVISIONS**

The policies are to contain, or be endorsed to contain, the following provisions:

#### **A. General Liability and Automobile Liability Coverages**

1. The member, its officials, agents, employees and volunteers are to be covered as additional insureds as respects: liability arising out of the Contractor's work, including activities performed by or on behalf of the Contractor; products and completed operations of the Contractor; premises owned, leased or used by the Contractor; or automobiles owned, leased, hired or borrowed by the Contractor. The coverage shall contain no special limitations on the scope of protection afforded to the member, its officials, agents, employees and volunteers.
2. The Contractor's insurance coverage shall be primary as respects the member, its officials, employees, agents and volunteers. Any insurance or self-insurance maintained by the member, its officials, agents, employees and volunteers shall be excess of Contractor's insurance and shall not contribute with it.
3. Any failure to comply with reporting provisions of the policies shall not affect coverage provided to the member, its officials, employees, agents and volunteers.
4. The Contractor's insurance shall contain a Severability of Interests/Cross Liability clause or language stating that Contractor's insurance shall apply

separately to each insured against whom claim is made or suit is brought, except with respect to the limits of the insurer's liability.

- 5. If any commercial general liability insurance is being provided under an excess or umbrella liability policy that does not "follow form," then the Contractor shall be required to name the member, its officials, employees, agents and volunteers as additional insureds.
- 6. All general liability coverages shall be provided on an occurrence policy form. Claims-made general liability policies will not be accepted.
- 7. The contractor and all subcontractors hereby agree to waive any limitation as to the amount of contribution recoverable against them by member. This specifically includes any limitation imposed by any state statute, regulation, or case law including any Workers' Compensation Act provision that applies a limitation to the amount recoverable in contribution such as Kotecki v. Cyclops Welding.

**B. Workers' Compensation and Employers' Liability Coverage**

The insurer shall agree to waive all rights of subrogation against the member, its officials, employees, agents and volunteers for losses arising from work performed by Contractor for the municipality.

- 1. NCCI Alternate Employer Endorsement (WC 000301) in place to insure that workers' compensation coverage applies under contractor's coverage rather than member's if the member is borrowing, leasing or in day to day control of contractors employee.

**Required if box is checked** .

**C. Professional Liability (Required if box is checked  )**

- 1. Professional liability insurance with limits not less than \$1,000,00 each claim with respect to negligent acts, errors and omissions in connection with professional services to be provided under the contract, with a deductible not-to-exceed \$50,000 without prior written approval.
- 2. If the policy is written on a claims-made form, the retroactive date must be equal to or preceding the effective date of the contract. In the event the policy is cancelled, non-renewed or switched to an occurrence form, the Contractor shall be required to purchase supplemental extending reporting period coverage for a period of not less than three (3) years.
- 3. Provide a certified copy of actual policy for review.
- 4. Recommended Required Coverage (architect, engineer, surveyor, consultant): Professional liability insurance that provides indemnification and defense for injury or damage arising out of acts, errors, or omissions in providing the following professional services, but not limited to the following:
  - a. Preparing, approving or failure to prepare or approve maps, drawings, opinions, report, surveys, change orders, designs or specifications;
  - b. Providing direction, instruction, supervision, inspection, engineering

services or failing to provide them, if that is the primary cause of injury or damage.

**D. All Coverages**

Each insurance policy required shall have the member expressly endorsed onto the policy as a Cancellation Notice Recipient. Should any of the policies be cancelled before the expiration date thereof, notice will be delivered in accordance with the policy provisions.

**ACCEPTABILITY OF INSURERS**

Insurance is to be placed with insurers with a Best's rating of no less than A-, VII and licensed to do business in the State of Illinois.

**VERIFICATION OF COVERAGE**

Contractor shall furnish the member with certificates of insurance naming the member, its officials, employees, agents and volunteers as additional insureds (Exhibit D), and with original endorsements affecting coverage required by this clause. The certificates and endorsements for each insurance policy are to be signed by a person authorized by that insurer to bind coverage on its behalf. The certificates and endorsements are to be received and approved by the member before any work commences. The following additional insured endorsements may be utilized: ISO Additional Insured Endorsements CG 2010 (Exhibit A) or CG 2026 (Exhibit B), and CG 2037 (Exhibit C) – Completed Operations, where required. The member reserves the right to request full certified copies of the insurance policies and endorsements.

**SUBCONTRACTORS**

Contractor shall include all subcontractors as insureds under its policies or shall furnish separate certificates and endorsements for each subcontractor. All coverages for subcontractors shall be subject to all of the requirements stated herein.

**ASSUMPTION OF LIABILITY**

The contractor assumes liability for all injury to or death of any person or persons including employees of the contractor, any sub-contractor, any supplier or any other person and assumes liability for all damage to property sustained by any person or persons occasioned by or in any way arising out of any work performed pursuant to this agreement.

**II. INDEMNITY/HOLD HARMLESS PROVISION**

To the fullest extent permitted by law, the Contractor hereby agrees to defend, indemnify and hold harmless the member, its officials, employees and agents against all injuries, deaths, loss, damages, claims, patent claims, suits, liabilities, judgments, cost and expenses, which may in anywise accrue against the member, its officials, agents and employees, arising in whole or in part or in consequence of the performance of this work by the Contractor, its employees, or subcontractors, or which may in anywise result therefore, except that arising out of the sole legal cause of the member, its employees or agents, the Contractor shall, at its own expense, appear, defend and pay all charges of attorneys and all costs and other expenses arising therefore or incurred in connections

therewith, and, if any judgment shall be rendered against the member, its officials, employees and agents, in any such action, the Contractor shall, at its own expense, satisfy and discharge the same.

Contractor expressly understands and agrees that any performance bond or insurance policies required by this contract, or otherwise provided by the Contractor, shall in no way limit the responsibility to indemnify, keep and save harmless and defend the member, its officials, employees and agents as herein provided.

The Contractor further agrees that to the extent that money is due the Contractor by virtue of this contract as shall be considered necessary in the judgment of the member, may be retained by the member to protect itself against said loss until such claims, suits, or judgments shall have been settled or discharged and/or evidence to that effect shall have been furnished to the satisfaction of the member.

### **III. SAFETY/LOSS PREVENTION**

#### **Safety/Loss Prevention Program Requirements**

- Successful bidder will provide written confirmation that a safety/loss prevention program was in place at least 90 days prior to submitting the bid proposal.
- Evidence of completed employee safety training can be provided.

#### **Regulatory Requirements**

- Successful bidder must comply with all applicable laws, regulations, and rules promulgated by any Federal, State, County, Municipal and/or other governmental unit or regulatory body now in effect or which may be in effect during the performance of the work. Included within the scope of the laws, regulations, and rules referred to in this paragraph but in no way to operate as a limitation, are Occupational Safety & Health Act (OSHA), Illinois Department of Labor (IDOL), Department of Transportation, all forms of traffic regulations, public utility, Intrastate and Interstate Commerce Commission regulations, Workers' Compensation Laws, Prevailing Wage Laws, the Social Security Act of the Federal Government and any of its titles, the Illinois Department of Human Rights, Human Rights Commission, or EEOC statutory provisions and rules and regulations.
- Evidence of specific regulatory compliance will be provided by bidder, if required by owner.

EXHIBIT A

POLICY NUMBER:

COMMERCIAL GENERAL LIABILITY  
CG 20 10 07 04

THIS ENDORSEMENT CHANGES THE POLICY. PLEASE READ IT CAREFULLY.

**ADDITIONAL INSURED – OWNERS, LESSEES OR  
CONTRACTORS – SCHEDULED PERSON OR  
ORGANIZATION**

This endorsement modifies insurance provided under the following:

COMMERCIAL GENERAL LIABILITY COVERAGE PART

SCHEDULE

Name Of Additional Insured Person(s) Or Organization(s):	Location(s) Of Covered Operations
Information required to complete this Schedule, if not shown above, will be shown in the Declarations.	

**A. Section II – Who Is An Insured** is amended to include as an additional insured the person(s) or organization(s) shown in the Schedule, but only with respect to liability for "bodily injury," "property damage" or "personal and advertising injury" caused, in whole or in part, by:

1. Your acts or omissions; or
2. The acts or omissions of those acting on your behalf;

in the performance of your ongoing operations for the additional insured(s) at the location(s) designated above.

**B.** With respect to the insurance afforded to these additional insureds, the following additional exclusions apply:

This insurance does not apply to "bodily injury" or "property damage" occurring after:

1. All work, including materials, parts or equipment furnished in connection with such work, on the project (other than service, maintenance or repairs) to be performed by or on behalf of the additional insured(s) at the location of the covered operations has been completed; or
2. That portion of "your work" out of which the injury or damage arises has been put to its intended use by any person or organization other than another contractor or subcontractor engaged in performing operations for a principal as a part of the same project.

EXHIBIT B

POLICY NUMBER:

COMMERCIAL GENERAL LIABILITY  
CG 20 26 07 04

THIS ENDORSEMENT CHANGES THE POLICY. PLEASE READ IT CAREFULLY.

**ADDITIONAL INSURED – DESIGNATED  
PERSON OR ORGANIZATION**

This endorsement modifies insurance provided under the following:

COMMERCIAL GENERAL LIABILITY COVERAGE PART

SCHEDULE

Name Of Additional Insured Person(s) Or Organization(s)
<p>EXAMPLE</p>

Information required to complete this Schedule, if not shown above, will be shown in the Declarations.

**Section II – Who Is An Insured** is amended to include as an additional insured the person(s) or organization(s) shown in the Schedule, but only with respect to liability for "bodily injury", "property damage" or "personal and advertising injury" caused, in whole or in part, by your acts or omissions or the acts or omissions of those acting on your behalf:

- A. In the performance of your ongoing operations; or
- B. In connection with your premises owned by or rented to you.

**EXHIBIT**

**C**

POLICY NUMBER:

**COMMERCIAL GENERAL LIABILITY  
CG 20 37 07 04**

**THIS ENDORSEMENT CHANGES THE POLICY. PLEASE READ IT CAREFULLY.**

**ADDITIONAL INSURED – OWNERS, LESSEES OR  
CONTRACTORS – COMPLETED OPERATIONS**

This endorsement modifies insurance provided under the following:

COMMERCIAL GENERAL LIABILITY COVERAGE PART

**SCHEDULE**

Name Of Additional Insured Person(s) Or Organization(s):	Location And Description Of Completed Operations
Information required to complete this Schedule, if not shown above, will be shown in the Declarations.	

**Section II – Who Is An Insured** is amended to include as an additional insured the person(s) or organization(s) shown in the Schedule, but only with respect to liability for "bodily injury" or "property damage" caused, in whole or in part, by "your work" at the location designated and described in the schedule of this endorsement performed for that additional insured and included in the "products-completed operations hazard".





**APPENDIX E**

**DUPAGE COUNTY PREVAILING WAGE RATES**

**OWNER COPY**

**CONTRACT**

**DuPage County Prevailing Wage Rates posted on 5/24/2021**

Trade Title	Rg	Type	C	Base	Foreman	Overtime					H/W	Pension	Vac	Trng	Other Ins
						M-F	Sa	Su	Hol						
ASBESTOS ABT-GEN	All	ALL		44.40	45.40	1.5	1.5	2.0	2.0	16.10	14.21	0.00	0.90		
ASBESTOS ABT-MEC	All	BLD		38.44	41.51	1.5	1.5	2.0	2.0	14.07	12.51	0.00	0.77		
BOILERMAKER	All	BLD		52.61	57.34	2.0	2.0	2.0	2.0	6.97	22.34	0.00	1.40		
BRICK MASON	All	BLD		47.56	52.32	1.5	1.5	2.0	2.0	11.20	20.51	0.00	0.97		
CARPENTER	All	ALL		49.76	51.76	1.5	1.5	2.0	2.0	11.79	23.34	0.00	0.73		
CEMENT MASON	All	ALL		47.00	49.00	2.0	1.5	2.0	2.0	15.75	19.73	0.00	1.00		
CERAMIC TILE FINISHER	All	BLD		41.80	41.80	1.5	1.5	2.0	2.0	11.25	13.41	0.00	0.88		
COMMUNICATION TECHNICIAN	All	BLD		34.25	37.05	1.5	1.5	2.0	2.0	12.60	23.04	2.75	0.68	0.10	
ELECTRIC PWR EQMT OP	All	ALL		46.06	62.84	1.5	1.5	2.0	2.0	6.75	12.90	0.00	1.15	1.38	
ELECTRIC PWR GRNDMAN	All	ALL		35.38	62.84	1.5	1.5	2.0	2.0	6.75	9.91	0.00	0.88	1.06	
ELECTRIC PWR LINEMAN	All	ALL		55.37	62.84	1.5	1.5	2.0	2.0	6.75	15.50	0.00	1.38	1.66	
ELECTRIC PWR TRK DRV	All	ALL		36.67	62.84	1.5	1.5	2.0	2.0	6.75	10.27	0.00	0.92	1.10	
ELECTRICIAN	All	BLD		41.49	45.49	1.5	1.5	2.0	2.0	12.60	25.90	6.00	0.85	0.10	
ELEVATOR CONSTRUCTOR	All	BLD		58.47	65.78	2.0	2.0	2.0	2.0	15.73	18.41	4.68	0.63		
FENCE ERECTOR	NE	ALL		44.42	46.42	1.5	1.5	2.0	2.0	13.68	15.40	0.00	0.65		
FENCE ERECTOR	W	ALL		47.99	51.83	2.0	2.0	2.0	2.0	13.06	24.15	0.00	1.03		
GLAZIER	All	BLD		46.35	47.85	1.5	2.0	2.0	2.0	14.79	22.67	0.00	1.26		
HEAT/FROST INSULATOR	All	BLD		51.25	54.33	1.5	1.5	2.0	2.0	14.07	14.26	0.00	0.77		
IRON WORKER	E	ALL		52.51	54.51	2.0	2.0	2.0	2.0	15.15	24.34	0.00	0.44		
IRON WORKER	W	ALL		47.99	51.83	2.0	2.0	2.0	2.0	13.06	24.15	0.00	1.03		
LABORER	All	ALL		44.40	45.15	1.5	1.5	2.0	2.0	16.10	14.21	0.00	0.90		
LATHER	All	ALL		49.76	51.76	1.5	1.5	2.0	2.0	11.79	23.34	0.00	0.73		
MACHINIST	All	BLD		49.68	52.18	1.5	1.5	2.0	2.0	7.93	8.95	1.85	1.47		
MARBLE FINISHER	All	ALL		35.73	49.05	1.5	1.5	2.0	2.0	11.20	18.71	0.00	0.87		
MARBLE MASON	All	BLD		46.71	51.38	1.5	1.5	2.0	2.0	11.20	19.98	0.00	0.95		
MATERIAL TESTER I	All	ALL		34.40		1.5	1.5	2.0	2.0	16.10	14.21	0.00	0.90		
MATERIALS TESTER II	All	ALL		39.40		1.5	1.5	2.0	2.0	16.10	14.21	0.00	0.90		
MILLWRIGHT	All	ALL		49.76	51.76	1.5	1.5	2.0	2.0	11.79	23.34	0.00	0.73		
OPERATING ENGINEER	All	BLD	1	52.10	56.10	2.0	2.0	2.0	2.0	20.90	17.85	2.00	2.15		
OPERATING ENGINEER	All	BLD	2	50.80	56.10	2.0	2.0	2.0	2.0	20.90	17.85	2.00	2.15		
OPERATING ENGINEER	All	BLD	3	48.25	56.10	2.0	2.0	2.0	2.0	20.90	17.85	2.00	2.15		

OPERATING ENGINEER	All	BLD	4	46.50	56.10	2.0	2.0	2.0	2.0	20.90	17.85	2.00	2.15	
OPERATING ENGINEER	All	BLD	5	55.85	56.10	2.0	2.0	2.0	2.0	20.90	17.85	2.00	2.15	
OPERATING ENGINEER	All	BLD	6	53.10	56.10	2.0	2.0	2.0	2.0	20.90	17.85	2.00	2.15	
OPERATING ENGINEER	All	BLD	7	55.10	56.10	2.0	2.0	2.0	2.0	20.90	17.85	2.00	2.15	
OPERATING ENGINEER	All	FLT		41.00	41.00	1.5	1.5	2.0	2.0	20.90	17.85	2.00	2.15	
OPERATING ENGINEER	All	HWY	1	50.30	54.30	1.5	1.5	2.0	2.0	20.90	17.85	2.00	2.15	
OPERATING ENGINEER	All	HWY	2	49.75	54.30	1.5	1.5	2.0	2.0	20.90	17.85	2.00	2.15	
OPERATING ENGINEER	All	HWY	3	47.70	54.30	1.5	1.5	2.0	2.0	20.90	17.85	2.00	2.15	
OPERATING ENGINEER	All	HWY	4	46.30	54.30	1.5	1.5	2.0	2.0	20.90	17.85	2.00	2.15	
OPERATING ENGINEER	All	HWY	5	45.10	54.30	1.5	1.5	2.0	2.0	20.90	17.85	2.00	2.15	
OPERATING ENGINEER	All	HWY	6	53.30	54.30	1.5	1.5	2.0	2.0	20.90	17.85	2.00	2.15	
OPERATING ENGINEER	All	HWY	7	51.30	54.30	1.5	1.5	2.0	2.0	20.90	17.85	2.00	2.15	
ORNAMENTAL IRON WORKER	E	ALL		51.63	54.13	2.0	2.0	2.0	2.0	14.23	22.25	0.00	1.25	
ORNAMENTAL IRON WORKER	W	ALL		47.99	51.83	2.0	2.0	2.0	2.0	13.06	24.15	0.00	1.03	
PAINTER	All	ALL		48.30	50.30	1.5	1.5	1.5	2.0	18.23	3.65	0.00	1.45	
PAINTER - SIGNS	All	BLD		40.74	45.75	1.5	1.5	2.0	2.0	3.04	3.90	0.00	0.00	
PILEDRIVER	All	ALL		49.76	51.76	1.5	1.5	2.0	2.0	11.79	23.34	0.00	0.73	
PIPEFITTER	All	BLD		50.75	53.75	1.5	1.5	2.0	2.0	10.85	20.85	0.00	2.92	
PLASTERER	All	BLD		47.57	50.42	1.5	1.5	2.0	2.0	11.20	20.17	0.00	0.96	
PLUMBER	All	BLD		52.00	55.10	1.5	1.5	2.0	2.0	16.22	15.60	0.00	1.40	
ROOFER	All	BLD		45.75	49.75	1.5	1.5	2.0	2.0	11.23	13.61	0.00	0.91	
SHEETMETAL WORKER	All	BLD		50.33	52.85	1.5	1.5	2.0	2.0	11.00	18.46	0.00	1.29	2.39
SPRINKLER FITTER	All	BLD		51.75	54.50	1.5	1.5	2.0	2.0	13.90	17.00	0.00	0.75	
STEEL ERECTOR	E	ALL		52.51	54.51	2.0	2.0	2.0	2.0	15.15	24.34	0.00	0.44	
STEEL ERECTOR	W	ALL		47.99	51.83	2.0	2.0	2.0	2.0	13.06	24.15	0.00	1.03	
STONE MASON	All	BLD		47.56	52.32	1.5	1.5	2.0	2.0	11.20	20.51	0.00	0.97	
TERRAZZO FINISHER	All	BLD		43.54	43.54	1.5	1.5	2.0	2.0	11.25	15.61	0.00	0.90	
TERRAZZO MASON	All	BLD		47.38	50.88	1.5	1.5	2.0	2.0	11.25	17.07	0.00	0.94	
TILE MASON	All	BLD		48.75	52.75	1.5	1.5	2.0	2.0	11.25	16.90	0.00	0.95	
TRAFFIC SAFETY WORKER	All	HWY		38.50	40.10	1.5	1.5	2.0	2.0	8.90	8.90	0.00	0.90	
TRUCK DRIVER	All	ALL	1	39.27	39.82	1.5	1.5	2.0	2.0	9.88	12.80	0.00	0.15	
TRUCK DRIVER	All	ALL	2	39.42	39.82	1.5	1.5	2.0	2.0	9.88	12.80	0.00	0.15	
TRUCK DRIVER	All	ALL	3	39.62	39.82	1.5	1.5	2.0	2.0	9.88	12.80	0.00	0.15	
TRUCK DRIVER	All	ALL	4	39.82	39.82	1.5	1.5	2.0	2.0	9.88	12.80	0.00	0.15	
TUCK POINTER	All	BLD		47.25	48.25	1.5	1.5	2.0	2.0	8.59	19.48	0.00	0.94	

**Legend****Rg** Region**Type** Trade Type - All,Highway,Building,Floating,Oil & Chip,Rivers**C** Class**Base** Base Wage Rate**OT M-F** Unless otherwise noted, OT pay is required for any hour greater than 8 worked each day, Mon through Fri. The number listed is the multiple of the base wage.**OT Sa** Overtime pay required for every hour worked on Saturdays**OT Su** Overtime pay required for every hour worked on Sundays**OT Hol** Overtime pay required for every hour worked on Holidays**H/W** Health/Welfare benefit**Vac** Vacation**Trng** Training**Other Ins** Employer hourly cost for any other type(s) of insurance provided for benefit of worker.

Explanations DUPAGE COUNTY

IRON WORKERS AND FENCE ERECTOR (WEST) - West of Route 53.

The following list is considered as those days for which holiday rates of wages for work performed apply: New Years Day, Memorial Day, Fourth of July, Labor Day, Thanksgiving Day, Christmas Day and Veterans Day in some classifications/counties. Generally, any of these holidays which fall on a Sunday is celebrated on the following Monday. This then makes work performed on that Monday payable at the appropriate overtime rate for holiday pay. Common practice in a given local may alter certain days of celebration. If in doubt, please check with IDOL.

## EXPLANATION OF CLASSES

ASBESTOS - GENERAL - removal of asbestos material/mold and hazardous materials from any place in a building, including mechanical systems where those mechanical systems are to be removed. This includes the removal of asbestos materials/mold and hazardous materials from ductwork or pipes in a building when the building is to be demolished at the time or at some close future date.

ASBESTOS - MECHANICAL - removal of asbestos material from mechanical systems, such as pipes, ducts, and boilers, where the mechanical systems are to remain.

## TRAFFIC SAFETY

Effective November 30, 2018, the description of the traffic safety worker trade in this County is as follows: Work associated with barricades, horses and drums used to reduce lane usage on highway work, the installation and removal of temporary, non-temporary or permanent lane, pavement or roadway markings, and the installation and removal of temporary road signs.

## CERAMIC TILE FINISHER

The grouting, cleaning, and polishing of all classes of tile, whether for interior or exterior purposes, all burned, glazed or unglazed products; all composition materials, granite tiles, warning detectable tiles, cement tiles, epoxy composite materials, pavers, glass, mosaics, fiberglass, and all substitute materials, for tile made in tile-like units; all mixtures in tile like form of cement, metals, and other materials that are for and intended for use as a finished floor surface, stair treads, promenade roofs, walks, walls, ceilings, swimming pools, and all other places where tile is to form a finished interior or exterior. The mixing of all setting mortars including but not limited to thin-set mortars, epoxies, wall mud, and any other sand and cement mixtures or adhesives when

used in the preparation, installation, repair, or maintenance of tile and/or similar materials. The handling and unloading of all sand, cement, lime, tile, fixtures, equipment, adhesives, or any other materials to be used in the preparation, installation, repair, or maintenance of tile and/or similar materials. Ceramic Tile Finishers shall fill all joints and voids regardless of method on all tile work, particularly and especially after installation of said tile work. Application of any and all protective coverings to all types of tile installations including, but not be limited to, all soap compounds, paper products, tapes, and all polyethylene coverings, plywood, masonite, cardboard, and any new type of products that may be used to protect tile installations, Blastrac equipment, and all floor scarifying equipment used in preparing floors to receive tile. The clean up and removal of all waste and materials. All demolition of existing tile floors and walls to be re-tiled.

#### COMMUNICATIONS TECHNICIAN

Low voltage installation, maintenance and removal of telecommunication facilities (voice, sound, data and video) including telephone and data inside wire, interconnect, terminal equipment, central offices, PABX, fiber optic cable and equipment, micro waves, V-SAT, bypass, CATV, WAN (wide area networks), LAN (local area networks), and ISDN (integrated system digital network), pulling of wire in raceways, but not the installation of raceways.

#### MARBLE FINISHER

Loading and unloading trucks, distribution of all materials (all stone, sand, etc.), stocking of floors with material, performing all rigging for heavy work, the handling of all material that may be needed for the installation of such materials, building of scaffolding, polishing if needed, patching, waxing of material if damaged, pointing up, caulking, grouting and cleaning of marble, holding water on diamond or Carborundum blade or saw for setters cutting, use of tub saw or any other saw needed for preparation of material, drilling of holes for wires that anchor material set by setters, mixing up of molding plaster for installation of material, mixing up thin set for the installation of material, mixing up of sand to cement for the installation of material and such other work as may be required in helping a Marble Setter in the handling of all material in the erection or installation of interior marble, slate, travertine, art marble, serpentine, alberene stone, blue stone, granite and other stones (meaning as to stone any foreign or domestic materials as are specified and used in building interiors and exteriors and customarily known as stone in the trade), carrara, sanionyx, vitrolite and similar opaque glass and the laying of all marble tile, terrazzo tile, slate tile and precast tile, steps, risers treads, base, or any other materials that may be used as substitutes for any of the aforementioned materials and which are used on interior and exterior which are installed in a similar manner.

MATERIAL TESTER I: Hand coring and drilling for testing of materials; field inspection of uncured concrete and asphalt.

MATERIAL TESTER II: Field inspection of welds, structural steel, fireproofing, masonry, soil, facade, reinforcing steel, formwork, cured concrete, and concrete and asphalt batch plants; adjusting proportions of bituminous mixtures.

#### OPERATING ENGINEER - BUILDING

Class 1. Asphalt Plant; Asphalt Spreader; Autograde; Backhoes with Caisson Attachment; Batch Plant; Benoto (requires Two Engineers); Boiler and Throttle Valve; Caisson Rigs; Central Redi-Mix Plant; Combination Back Hoe Front End-loader Machine; Compressor and Throttle Valve; Concrete Breaker (Truck Mounted); Concrete Conveyor; Concrete Conveyor (Truck Mounted); Concrete Paver Over 27E cu. ft; Concrete Paver 27E cu. ft. and Under; Concrete Placer; Concrete Placing Boom; Concrete Pump (Truck Mounted); Concrete Tower; Cranes, All; Cranes, Hammerhead; Cranes, (GCI and similar Type); Creter Crane; Spider Crane; Crusher, Stone, etc.; Derricks, All; Derricks, Traveling; Formless Curb and Gutter Machine; Grader, Elevating; Grouting Machines; Heavy Duty Self-Propelled Transporter or Prime Mover; Highlift Shovels or Front Endloader 2-1/4 yd. and over; Hoists, Elevators, outside type rack and pinion and similar machines; Hoists, One, Two and Three Drum; Hoists, Two Tugger One Floor; Hydraulic Backhoes; Hydraulic Boom Trucks; Hydro Vac (and similar equipment); Locomotives, All; Motor Patrol; Lubrication Technician; Manipulators; Pile Drivers and Skid Rig; Post Hole Digger; Pre-Stress Machine; Pump Cretes Dual Ram; Pump Cretes: Squeeze Cretes-Screw Type Pumps; Gypsum Bulker and Pump; Raised and Blind Hole Drill; Roto Mill Grinder; Scoops - Tractor Drawn; Slip-Form Paver; Straddle Buggies; Operation of Tie Back Machine; Tournapull; Tractor with Boom and Side Boom; Trenching

## Machines.

Class 2. Boilers; Broom, All Power Propelled; Bulldozers; Concrete Mixer (Two Bag and Over); Conveyor, Portable; Forklift Trucks; Highlift Shovels or Front Endloaders under 2-1/4 yd.; Hoists, Automatic; Hoists, Inside Elevators; Hoists, Sewer Dragging Machine; Hoists, Tugger Single Drum; Laser Screed; Rock Drill (Self-Propelled); Rock Drill (Truck Mounted); Rollers, All; Steam Generators; Tractors, All; Tractor Drawn Vibratory Roller; Winch Trucks with "A" Frame.

Class 3. Air Compressor; Combination Small Equipment Operator; Generators; Heaters, Mechanical; Hoists, Inside Elevators (remodeling or renovation work); Hydraulic Power Units (Pile Driving, Extracting, and Drilling); Pumps, over 3" (1 to 3 not to exceed a total of 300 ft.); Low Boys; Pumps, Well Points; Welding Machines (2 through 5); Winches, 4 Small Electric Drill Winches.

Class 4. Bobcats and/or other Skid Steer Loaders; Oilers; and Brick Forklift.

Class 5. Assistant Craft Foreman.

Class 6. Gradall.

Class 7. Mechanics; Welders.

## OPERATING ENGINEERS - HIGHWAY CONSTRUCTION

Class 1. Asphalt Plant; Asphalt Heater and Planer Combination; Asphalt Heater Scarfire; Asphalt Spreader; Autograder/GOMACO or other similar type machines; ABG Paver; Backhoes with Caisson Attachment; Ballast Regulator; Belt Loader; Caisson Rigs; Car Dumper; Central Redi-Mix Plant; Combination Backhoe Front Endloader Machine, (1 cu. yd. Backhoe Bucket or over or with attachments); Concrete Breaker (Truck Mounted); Concrete Conveyor; Concrete Paver over 27E cu. ft.; Concrete Placer; Concrete Tube Float; Cranes, all attachments; Cranes, Tower Cranes of all types: Creter Crane; Spider Crane; Crusher, Stone, etc.; Derricks, All; Derrick Boats; Derricks, Traveling; Dredges; Elevators, Outside type Rack & Pinion and Similar Machines; Formless Curb and Gutter Machine; Grader, Elevating; Grader, Motor Grader, Motor Patrol, Auto Patrol, Form Grader, Pull Grader, Subgrader; Guard Rail Post Driver Truck Mounted; Hoists, One, Two and Three Drum; Heavy Duty Self-Propelled Transporter or Prime Mover; Hydraulic Backhoes; Backhoes with shear attachments up to 40' of boom reach; Lubrication Technician; Manipulators; Mucking Machine; Pile Drivers and Skid Rig; Pre-Stress Machine; Pump Cretes Dual Ram; Rock Drill - Crawler or Skid Rig; Rock Drill - Truck Mounted; Rock/Track Tamper; Roto Mill Grinder; Slip-Form Paver; Snow Melters; Soil Test Drill Rig (Truck Mounted); Straddle Buggies; Hydraulic Telescoping Form (Tunnel); Operation of Tieback Machine; Tractor Drawn Belt Loader; Tractor Drawn Belt Loader (with attached pusher - two engineers); Tractor with Boom; Tractaire with Attachments; Traffic Barrier Transfer Machine; Trenching; Truck Mounted Concrete Pump with Boom; Raised or Blind Hole Drills (Tunnel Shaft); Underground Boring and/or Mining Machines 5 ft. in diameter and over tunnel, etc; Underground Boring and/or Mining Machines under 5 ft. in diameter; Wheel Excavator; Widener (APSCO).

Class 2. Batch Plant; Bituminous Mixer; Boiler and Throttle Valve; Bulldozers; Car Loader Trailing Conveyors; Combination Backhoe Front Endloader Machine (Less than 1 cu. yd. Backhoe Bucket or over or with attachments); Compressor and Throttle Valve; Compressor, Common Receiver (3); Concrete Breaker or Hydro Hammer; Concrete Grinding Machine; Concrete Mixer or Paver 7S Series to and including 27 cu. ft.; Concrete Spreader; Concrete Curing Machine, Burlap Machine, Belting Machine and Sealing Machine; Concrete Wheel Saw; Conveyor Muck Cars (Haglund or Similar Type); Drills, All; Finishing Machine - Concrete; Highlift Shovels or Front Endloader; Hoist - Sewer Dragging Machine; Hydraulic Boom Trucks (All Attachments); Hydro-Blaster; Hydro Excavating (excluding hose work); Laser Screed; All Locomotives, Dinky; Off-Road Hauling Units (including articulating) Non Self-Loading Ejection Dump; Pump Cretes: Squeeze Cretes - Screw Type Pumps, Gypsum Bulker and Pump; Roller, Asphalt; Rotary Snow Plows; Rototiller, Seaman, etc., self-propelled; Self-Propelled Compactor; Spreader - Chip - Stone, etc.; Scraper - Single/Twin Engine/Push and Pull; Scraper - Prime Mover in Tandem (Regardless of Size); Tractors pulling attachments, Sheeps Foot, Disc, Compactor, etc.; Tug Boats.

Class 3. Boilers; Brooms, All Power Propelled; Cement Supply Tender; Compressor, Common Receiver (2); Concrete Mixer (Two

Bag and Over); Conveyor, Portable; Farm-Type Tractors Used for Mowing, Seeding, etc.; Forklift Trucks; Grouting Machine; Hoists, Automatic; Hoists, All Elevators; Hoists, Tugger Single Drum; Jeep Diggers; Low Boys; Pipe Jacking Machines; Post-Hole Digger; Power Saw, Concrete Power Driven; Pug Mills; Rollers, other than Asphalt; Seed and Straw Blower; Steam Generators; Stump Machine; Winch Trucks with "A" Frame; Work Boats; Tamper-Form-Motor Driven.

Class 4. Air Compressor; Combination - Small Equipment Operator; Directional Boring Machine; Generators; Heaters, Mechanical; Hydraulic Power Unit (Pile Driving, Extracting, or Drilling); Light Plants, All (1 through 5); Pumps, over 3" (1 to 3 not to exceed a total of 300 ft.); Pumps, Well Points; Vacuum Trucks (excluding hose work); Welding Machines (2 through 5); Winches, 4 Small Electric Drill Winches.

Class 5. SkidSteer Loader (all); Brick Forklifts; Oilers.

Class 6. Field Mechanics and Field Welders

Class 7. Dowell Machine with Air Compressor; Gradall and machines of like nature.

#### OPERATING ENGINEER - FLOATING

Diver. Diver Wet Tender, Diver Tender, ROV Pilot, ROV Tender

#### TRUCK DRIVER - BUILDING, HEAVY AND HIGHWAY CONSTRUCTION

Class 1. Two or three Axle Trucks. A-frame Truck when used for transportation purposes; Air Compressors and Welding Machines, including those pulled by cars, pick-up trucks and tractors; Ambulances; Batch Gate Lockers; Batch Hopperman; Car and Truck Washers; Carry-alls; Fork Lifts and Hoisters; Helpers; Mechanics Helpers and Greasers; Oil Distributors 2-man operation; Pavement Breakers; Pole Trailer, up to 40 feet; Power Mower Tractors; Self-propelled Chip Spreader; Skipman; Slurry Trucks, 2-man operation; Slurry Truck Conveyor Operation, 2 or 3 man; Teamsters; Unskilled Dumpman; and Truck Drivers hauling warning lights, barricades, and portable toilets on the job site.

Class 2. Four axle trucks; Dump Crets and Adgetors under 7 yards; Dumpsters, Track Trucks, Euclids, Hug Bottom Dump Turnapulls or Turnatrailers when pulling other than self-loading equipment or similar equipment under 16 cubic yards; Mixer Trucks under 7 yards; Ready-mix Plant Hopper Operator, and Winch Trucks, 2 Axles.

Class 3. Five axle trucks; Dump Crets and Adgetors 7 yards and over; Dumpsters, Track Trucks, Euclids, Hug Bottom Dump Turnatrailers or turnapulls when pulling other than self-loading equipment or similar equipment over 16 cubic yards; Explosives and/or Fission Material Trucks; Mixer Trucks 7 yards or over; Mobile Cranes while in transit; Oil Distributors, 1-man operation; Pole Trailer, over 40 feet; Pole and Expandable Trailers hauling material over 50 feet long; Slurry trucks, 1-man operation; Winch trucks, 3 axles or more; Mechanic--Truck Welder and Truck Painter.

Class 4. Six axle trucks; Dual-purpose vehicles, such as mounted crane trucks with hoist and accessories; Foreman; Master Mechanic; Self-loading equipment like P.B. and trucks with scoops on the front.

#### TERRAZZO FINISHER

The handling of sand, cement, marble chips, and all other materials that may be used by the Mosaic Terrazzo Mechanic, and the mixing, grinding, grouting, cleaning and sealing of all Marble, Mosaic, and Terrazzo work, floors, base, stairs, and wainscoting by hand or machine, and in addition, assisting and aiding Marble, Masonic, and Terrazzo Mechanics.

#### Other Classifications of Work:

For definitions of classifications not otherwise set out, the Department generally has on file such definitions which are available. If a task to be performed is not subject to one of the classifications of pay set out, the Department will upon being contacted state

which neighboring county has such a classification and provide such rate, such rate being deemed to exist by reference in this document. If no neighboring county rate applies to the task, the Department shall undertake a special determination, such special determination being then deemed to have existed under this determination. If a project requires these, or any classification not listed, please contact IDOL at 217-782-1710 for wage rates or clarifications.

#### LANDSCAPING

Landscaping work falls under the existing classifications for laborer, operating engineer and truck driver. The work performed by landscape plantsman and landscape laborer is covered by the existing classification of laborer. The work performed by landscape operators (regardless of equipment used or its size) is covered by the classifications of operating engineer. The work performed by landscape truck drivers (regardless of size of truck driven) is covered by the classifications of truck driver.

#### MATERIAL TESTER & MATERIAL TESTER/INSPECTOR I AND II

Notwithstanding the difference in the classification title, the classification entitled "Material Tester I" involves the same job duties as the classification entitled "Material Tester/Inspector I". Likewise, the classification entitled "Material Tester II" involves the same job duties as the classification entitled "Material Tester/Inspector II".



**APPENDIX F**  
**GEOTECHNICAL REPORT**



**FEBRUARY 25, 2020  
SEECO JOB NO. 12182G**

**FINAL  
SUBSURFACE EXPLORATION, LABORATORY TESTING AND  
GEOTECHNICAL ENGINEERING AND ANALYSIS  
FOR THE PROPOSED CHARLES AVENUE  
IMPROVEMENT PROJECT LOCATED  
IN THE VILLAGE OF VILLA PARK, DUPAGE COUNTY, ILLINOIS**

**PREPARED FOR:**

**MR. MARC GRIGAS, P.E.  
STRAND ASSOCIATES, INC.  
1170 S. HOUBOLT ROAD  
JOLIET, ILLINOIS 60431**

**PREPARED BY:**

**SEECO CONSULTANTS, INC.  
7350 DUVAN DRIVE  
TINLEY PARK, ILLINOIS 60477  
(708) 429-1666**

**TABLE OF CONTENTS**

	<b><u>PAGE</u></b>
REPORT SUMMARY .....	1
PROJECT OVERVIEW .....	5
Introduction .....	5
General Site Conditions and Project Description .....	6
Site Geology .....	8
FIELD AND LABORATORY ANALYSIS AND RESULTS .....	10
Subsurface Site Exploration Procedures .....	10
Geotech Laboratory Testing Program .....	11
Environmental Laboratory Soil Testing Program .....	11
Site Soil Conditions .....	13
Site Groundwater Conditions .....	14
ENGINEERING ANALYSIS AND RESULTS .....	14
Braced Excavations for Water Main and Storm Water Sewer Construction .....	16
Manhole Structures and Pipe Bedding .....	18
Trench Backfill .....	19
Cured-In-Place Pipe (CIPP) Lining .....	19
Full Depth Pavement Design and Construction Recommendations .....	20
Pavement Site Preparation .....	22
Pavement Design .....	24
Potential Construction Problems .....	25
Construction Consultation Engineering .....	26
Closing Remarks .....	27
APPENDIX .....	28

### REPORT SUMMARY

This geotechnical report is prepared for the proposed Charles Avenue Improvements Project that consist of approximately 1,245 linear feet of full depth pavement reconstruction, installation of approximately 1300 linear feet of 8 inch Ductile Iron Pipe (DIP) water main and installation of approximately 1217 feet of 12 inch to 21 inch diameter RCP storm sewers within the project limits on Charles Avenue from St. Charles Road to Oak Street in the Village of Villa Park, Illinois.

The existing Charles Avenue is proposed to be full depth pavement reconstruction starting from approximate Station 101+92 at St. Charles Road and ending at approximate Station 114+37 at Oak Street for a total improvement length of approximately 1,245 linear feet. The proposed pavement section proposed by Strand Associates, Inc., Project Civil Engineer consists of 2 inches of HMA Surface Course, Mix D, IL-9.5, N50 overlying 4 inches of HMA Binder Course, IL-19, N50 overlying a minimum 6 inches of compacted CA-6, Type B Crushed Stone Base Course with Aggregate Subgrade Improvement. A new 8 inch DIP water main is proposed to be installed using Open Cut Trench Excavation along the entire length of Charles Avenue starting at approximate station 101+35 and ending at approximate station 114+35 for the total approximate installation length of 1300 feet. The proposed new water main will be installed at approximately 6.5 feet to 8.5 feet below the existing pavement surface. Approximately 1217 feet of proposed 12 inches to 21 inches diameter RCP storm sewer will be installed along Charles Avenue from approximate station 103+75 to 112+35. The proposed inverts range from approximately 4 feet to 6.5 feet below existing grade level and is proposed to be installed using Open Cut Trench Excavation. Lastly, the existing 10 inches diameter VCP Sanitary Sewer pipe will be spot repaired using CIPP (Cured In Place Pipe) liner for a total approximate length of 600 feet (for 2 of the 4 segments only) and sanitary sewer service connections at a few locations will be removed and replaced. At a few locations, along the existing Sanitary Sewer pipe alignment, exploration trench will be excavated to determine the depth, size, and location of the existing sanitary sewer service lines.

A total of four (4) pavement core borings (B-1 to B-4) were cored, drilled, and sampled through approximately 1.5 inches to 1.75 inches of bituminous concrete pavement overlying approximately 6.5 inches to 7.5 inches of Portland Cement Concrete base which is underlain by moist medium to stiff dark brown, brown, gray, and black clay fill to approximate depths of 1.5 feet to 3.5 feet below the existing grade level. Underlying the above mentioned clay fill soils, borings B-1 to B-4 generally encountered very stiff to hard brown and gray to brown virgin clay to approximate depths of 8.5 feet to 11 feet below existing grade level which is underlain by very stiff gray virgin clay to the termination depths of 15 feet to 20 feet below existing grade level.

Bedrock was not encountered in pavement core borings B-1 to B-4 throughout the drilling depth of 15 feet to 20 feet below existing grade level. Therefore, bedrock excavation is not anticipated for this project.

Groundwater was not encountered in any of the pavement core borings (B-1 to B-4) to the termination depths of 15 feet to 20 feet below the existing ground surface elevation while drilling, sampling, and removal of the hollow stem augers from the boreholes for this subsurface exploration on 5/31/19. However, yearly and seasonal fluctuations in the groundwater levels are possible due to changes in hydrogeological conditions at this site over time. The project site soil conditions and groundwater conditions are provided in greater detail in the body of this report and are also provided on the **Core Boring Logs** given in the **Appendix** of this Report.

Based on the soil conditions, it is recommended that the proposed 8-inch diameter DIP water main should be installed at the designed invert depths of approximately 6.5 feet to 8.5 feet below the existing pavement grade and the proposed storm sewer can be installed at the design depths of 4 feet to 6.5 feet below the existing pavement grade. The anticipated soil conditions at the proposed design invert

elevations of the water main and storm sewer will be brown and gray to brown, very stiff to hard virgin clay (A-6) which are suitable for bearing.

The proposed water main and storm sewers to be located on Charles Avenue from St. Charles Road to Oak Street in the Village of Villa Park, Illinois should be installed in open cut trenches braced with single or stacked trench boxes. A steel trench protection box should be designed on the basis of the lateral earth pressures given on the **Apparent Lateral Earth Pressure Diagram for Trench Protection Box Design in Equivalent Clayey Soils (H≤10 Feet Deep)** as given in the **Appendix** of this report. The design of the trench protection box should be performed by a Registered Structural Engineer of Illinois. The minimum surcharge due to heavy construction equipment should be considered as 600 psf per running foot. For trench excavations the steel trench box sidewalls and struts should be capable of resisting an approximate minimum of 820 psf per foot (for maximum 10 foot depth) of box length of lateral earth pressure in comparison with the trench box allowable lateral pressure capacity.

The HMA full depth pavement reconstruction of Charles Avenue pavement from St. Charles Road to Oak Street should be designed based on an IBR value of 3 for the existing subgrade consisting of medium to stiff dark brown, brown, gray, and black clay fill overlying very stiff to hard brown and gray clay as encountered in pavement core borings B-1 to B-4. The pavement full depth reconstruction should be designed according to the Village of Villa Park residential subdivision street design criteria and the Modified AASTHO design method in Chapter 54 of the IDOT Bureau of Design and Environment Manual, current edition.

Two (2) of the four (4) borings appear to require undercut which are borings B-1 and B-3 respectively due to low strength (approximately 0.75 tsf) and higher moisture contents (25% to 27%) in which this material may not pass a proofroll inspection. Therefore it is recommended to anticipate undercutting of

these two (2) locations and adjacent areas and should be verified with proofroll operations in the field at the time of construction before undercutting.

Potential undercut Area #1 is located from approximate Station 101+92 to Station 103+90 (approximately 198 linear feet) taken from the project start to the approximate halfway point between borings B-1 and B-2 with a potential maximum undercut depth of 2 feet. The area should be undercut from back of curb to back of curb approximately 27 feet and should be undercut to the virgin very stiff brown and gray clay (A-6) at approximately 680.5 MSL. The proposed finish subgrade elevation is at approximately 682.5 MSL which gives a maximum undercut depth of approximately 2 feet from the proposed finish subgrade elevation. The anticipated volume of potential undercut is approximately 396 cubic yards for this area adjacent to boring B-1. Potential undercut Area #2 is located from approximate Station 107+45 to Station 111+25 (approximately 380 linear feet) taken from the approximate halfway point between borings B-2 and B-3 and also the approximate halfway point between borings B-3 and B-4. The area should be undercut from back of curb to back of curb approximately 27 feet and should be undercut to the virgin very stiff brown and gray clay (A-6) at approximately 675.5 MSL. The proposed finish subgrade elevation is at approximately 676.0 MSL which gives a maximum undercut depth of approximately 0.5 feet from the proposed finish subgrade elevation. The anticipated volume of potential undercut is approximately 190 cubic yards for this area adjacent to boring B-3. SEECO believes this area has a high probability to fail a proof roll because of the subgrade soils excessively wet moisture content.

The undercut areas (if required) should be backfilled with IDOT CA-6 crushed stone as per IDOT "Standard Specifications for Road and Bridge Construction," 2016 Edition. The CA-6 crushed stone should be placed in maximum 8 inch loose lifts with each lift compacted to a minimum 95% of Standard Proctor per AASHTO T99 to the proposed subgrade elevation.

Undercutting per the requirements given in this geotech report should be performed by the earthwork subcontractor using a backhoe in the presence of the Field Geotechnical Engineer after the exact undercut depth and lateral extent is determined in the field by the Field Geotechnical Engineer with the use of a SCP or DCP per IDOT's Subgrade Stability Manual. If the SCP or DCP has to be utilized to determine possible depths of undercut then Tensar Geogrid TX160 or equivalent should be examined to determine if geogrid could be used to reduce undercut depth and to provide reinforcement as well as act as a separation barrier of materials at the bottom of the undercut and the granular refill material. See IDOT Subgrade Stability Manual for details.

The water main and storm sewer construction should be done in accordance with the ISPE "Standard Specification for Water & Sewer Main Construction in Illinois," Seventh Edition, dated 2014. Detailed recommendations regarding the construction of the pavement, water main, and storm sewer are given in the body of this report.

## **PROJECT OVERVIEW**

### **Introduction**

This geotechnical report is prepared for the proposed Charles Avenue Improvements Project that consist of approximately 1,245 linear feet of full depth pavement reconstruction, installation of approximately 1300 linear feet of 8 inch Ductile Iron Pipe (DIP) water main and installation of approximately 1217 feet of 12 inch to 21 inch diameter RCP storm sewers within the project limits on Charles Avenue from St. Charles Road to Oak Street in the Village of Villa Park, Illinois.

The purpose of this report is to describe the subsurface soil conditions encountered at this site, to evaluate the physical characteristics of the soil by means of a geotech laboratory testing program and provide general engineering recommendations regarding the adequacy of the subsurface soils and excavations for the installation of the proposed water main and storm sewer, and total pavement

reconstruction recommendations, provide general construction recommendations, and address possible problems due to soil and/or prevalent groundwater conditions at this project site.

This scope of services include the field screening of the soil samples using visual, olfactory senses, and a photo-ionization detector (PID) for the presence of volatile organic vapors and one (1) representative soil sample was environmental chemical tested for VOCs, SVOCs, 8 RCRA Metals, and pH from pavement Core Boring B-1, S-1, 0.5 to 2.5 ft. Any statements in this report or on the boring logs regarding odors, colors, unusual or suspicious items or conditions are strictly for the information of the client.

This report was prepared at the request of Mr. Marc Grigas, P.E. of Strand Associates Inc., per SEECO Consultants, Inc. Proposal and Contract dated February 15, 2019 and also Strand Associates, Inc. Agreement for Professional Services dated May 15, 2019 with Strand Project No. 4627.001.

### **General Site Conditions and Project Description**

The project site is located in a developed residential area of Village of Villa Park, Illinois and the full depth pavement reconstruction will be along Charles Avenue from St. Charles Road to Oak Street (approximate station 101+92 to 114+37) for a total pavement improvement length of approximately 1245 linear feet and the proposed water main will be installed along the entire project length (approximate station 101+35 to 114+35) for a total installation length of approximately 1300 linear feet in the Village of Villa Park, Illinois. Approximately 1217 feet of proposed storm sewer will be installed along Charles Avenue from approximate station 103+75 to 112+35. And approximately 600 feet of the existing 10 inches diameter Vitrified Clay Pipe (VCP) Sanitary Sewer pipe will be spot repaired using CIPP (Cured In Place Pipe) liner.

Charles Avenue is 24 feet wide, two lane road with one lane in either direction and combination concrete curb and gutter type B-6.12 is installed on either side of the pavement. The existing pavement

section consists of approximately 1.5 inches to 1.75 inches of bituminous concrete pavement underlain by approximately 6.5 inches to 7.5 inches of Portland Cement Concrete Base. The road gently slopes down from St. Charles Road to Elm Street and gently slopes up from Elm Street to Oak Street and the existing pavement ground surface elevation ranges from approximately 676.28 MSL to 685.58 MSL. The existing pavement is in poor condition and has reached the end of its design life. The existing pavement is potholed and has excessive alligator cracking, longitudinal cracking, transverse cracking, and rutting indicating pavement failure due to freeze-thaw cycle and poor subgrade soils.

The existing Charles Avenue is proposed to be full depth pavement reconstruction starting from approximate Station 101+92 at St. Charles Road and ending at approximate Station 114+37 at Oak Street for a total improvement length of approximately 1,245 linear feet. The proposed Charles Avenue finished pavement centerline profile will be regraded a maximum of 0.62 feet to 0.64 feet below the existing pavement centerline profile for approximately 200 feet and the remaining of the proposed Charles Avenue finished pavement centerline grade and location is proposed to remain the same. The proposed pavement section proposed by Strand Associates, Inc., Project Civil Engineer consists of 2 inches of HMA Surface Course, Mix D, IL-9.5, N50 overlying 4 inches of HMA Binder Course, IL-19, N50 overlying a minimum 6 inches of compacted CA-6, Type B Crushed Stone Base Course with Aggregate Subgrade Improvement. A woven geotextile fabric will be placed on top of finished subgrade before placing of compacted Crushed Stone Base Course. New combination concrete curb and gutter type B-6.12 over 4 inches of compacted crushed stone base is proposed to be constructed on both side of the proposed new pavement section. The existing concrete sidewalk will be removed and replaced with 5-inch of Portland Cement Concrete (PCC) Sidewalk underlain by 4-inch of compacted crushed stone base.

A new 8 inch DIP Class 52 water main is proposed to be installed using Open Cut Trench Excavation along the entire length of Charles Avenue starting at approximate station 101+35 and ending at

approximate station 114+35 for the total approximate installation length of 1300 feet. The proposed new water main will be installed at approximately 6.5 feet to 8.5 feet below the existing pavement surface grade.

Approximately 1217 feet of proposed 12 inches to 21 inches diameter RCP storm sewer will be installed along Charles Avenue from approximate station 103+75 to 112+35. The proposed inverts range from approximately 4 feet to 6.5 feet below existing grade level and is proposed to be installed using Open Cut Trench Excavation method.

Lastly, the existing 10 inches diameter VCP Sanitary Sewer pipe will be spot repaired using CIPP (Cured In Place Pipe) liner for a total approximate length of 600 feet and sanitary sewer service connections at several locations will be removed and replaced. At a few locations, along the existing Sanitary Sewer pipe alignment, exploration trench will be excavated to determine the depth, size, and location of the existing sanitary sewer service lines.

The project information presented above is referenced from the project information given in an email to Mr. Matt Boladz, P.E. of SEECO Consultants, Inc. by Mr. Marc Grigas, P.E. of Strand Associates Inc. on 6/4/2019 and based on the Pre Final Project Plans, titled 'Charles Avenue Improvement Project for the Village of Villa Park, DuPage County, Illinois' total 31 Sheets, dated February, 2020 and prepared by Strand Associates, Inc., Project Civil Engineer and provided to the principal author, Mr. Sandip Dahal, of this report by Mr. Marc Grigas, P.E. of Strand Associates Inc. through email and phone conversation dated 2/13/2020 and 2/14/2020.

### **Site Geology**

The native soils at the project site are the product of the result of Wisconsinan Stage of the Continental Glacier. The Wisconsinan Ice was the last to cover the North American Continent, receding from this

area some 13,500 years ago. Present land forms in this area are the results of the Wisconsin glacial action during the Pleistocene Epoch. The soils were formed from the natural deposition erosion and weathering processes that have prevailed to the present time. The Pre-Wisconsin glacial deposits are found only in deep bedrock valleys and ravines where they were sheltered from the erosive action of the Wisconsin Ice Age.

According to the Illinois State Geological Survey (ISGS) Surficial Geology of The Chicago Region (Willman, H.B. and Lineback, Jerry A., 1970), the soils at this project site below the existing pavement and clay fill have been assigned to the Valparaiso undifferentiated of the Valparaiso Morainic System of the Wadsworth and Haeger Members of the Wedron Formation deposited during the Woodfordian Substage of the Wisconsin Stage. According to the geology map referenced above these soils are generally defined as mostly brown and gray to gray clayey and silty clayey glacial till, relatively low in content of pebbles, cobbles, boulders with local lenses of silt commonly mantled with 1 to 2 feet of modified loess.

The pavement core borings performed along Charles Avenue on May 31, 2019 by SEECO Consultants, Inc. indicates that the original virgin soils below the pavement section overlying silty clay fill at this project site consist of stiff to very stiff to hard, brown and gray silty clay glacial till. These soil borings in general, confirm the ISGS published surficial geology map for this area below the surficial pavement section and silty clay fill. The details of the onsite soil conditions can be found in the **Site Soil Conditions** subparagraph of the **FIELD AND LABORATORY ANALYSIS AND RESULTS** section of this report and **Core Boring Logs** given in the **Appendix** of this Report.

## FIELD AND LABORATORY ANALYSIS AND RESULTS

### Subsurface Site Exploration Procedures

Four (4) pavement core-borings (B-1 to B-4) were drilled and sampled to termination depths of 15 feet to 20 feet below the existing ground level by SEECO Consultants, Inc. on May 31, 2019 for the proposed Charles Avenue Improvement Project. The core-borings for this project were performed at the approximate locations indicated on the Core Boring Location Plan given in the Appendix of this report. The core borings were located in the field by a representative of SEECO Consultants, Inc. before coring and drilling commenced in the field.

Four (4) pavement cores (C-1 to C-4) were obtained from the existing pavement along Charles Avenue in Villa Park, Illinois using a 4" diameter diamond bit tipped core barrel attached to a portable coring machine by a two-man drilling crew from SEECO Consultants Inc. Refer to the Core Boring Location Plan given in the Appendix of this report for approximate core-boring locations.

After obtaining the pavement cores, the base course and the subgrade soils were drilled and sampled by a truck-mounted rotary-type Diedrich (Model D-50) drill rig with a 2 man drill crew from SEECO Consultants Inc. which advances the borehole by the hollow stem auger method. The soil samples were obtained utilizing split spoon samples in accordance with ASTM D 1586-18. The split barrel sampling procedure, a split spoon sampler has a two-inch outside diameter and inside diameter of 1-3/8 inches and a length of two feet is driven 18 inches into the soil. The sampler is advanced by driving with a 140 pound weight falling freely from a height of 30 inches with the Standard Penetration Resistance being recorded as the number of blows required to advance the sampling spoon a distance of 18 inches after an initial driving of six inches has been used to seat the sampler.

The thickness of the pavement cores and base course were measured in the field at the time of drilling and sampling. The subgrade soils that were sampled were placed into glass jars with screw type lids for further examination and testing in SEECO's Geotech laboratory. See the Core Boring Logs in the Appendix of this report.

### Geotech Laboratory Testing Program

The geotechnical laboratory testing program consists of performing in-situ natural moisture content, visual classification of all soil samples and unconfined compressive strength tests on the basis of calibrated penetrometer readings on all cohesive soil samples.

In-situ moisture content or natural water content is determined in the geotech laboratory as follows: (ASTM D 2216-19). A portion of each sample, consisting of an one-inch piece is weighed, oven-dried at  $105^{\circ}\pm 5^{\circ}\text{C}$ , and reweighed to obtain the weight of water in the sample. The moisture content is a ratio of the weight of water in the soil sample to the weight of the dry soil expressed as a percentage of the total dry weight of the soil sample.

After completion of the geotech testing program, each soil sample was visually classified on the basis of texture and plasticity in accordance with the AASHTO Soil Classification System. The estimated group symbol according to this system is included following the description of the soil on the Core Boring Logs. A brief explanation of the AASHTO Soil Classification System is included in the Appendix of this report. All laboratory test data is noted on the Core Boring Logs which are also included in the Appendix of this report.

### Environmental Laboratory Soil Testing Program

A geoenvironmental engineer from SEECO Consultants, Inc. environmentally screened the soil samples using photoionization device (PID) readings in the SEECO Consultants geotech laboratory

utilizing a Mini RAE 3000 PID 11.8 (eV) lamp in conjunction with visual and olfactory observations to determine the presence of petroleum contamination in the subsurface soils. The OVM PID readings of the soil samples obtained for this exploration are given on the Core Boring Logs in the Appendix of this report and are all 0.0 PPM. The visual and olfactory observations indicate no organic, sewage and/or petroleum odors were present in the soil samples taken. Based on the PID readings and visual and olfactory observations, it was determined that the soil samples obtained for this exploration do not appear to be contaminated at the location of these boreholes.

Also, one (1) soil sample was selected for environmental chemical testing at boring B-1, Sample 1, 0.5 to 2.5 foot depth in order to determine if the chemical constituents are above the 'Maximum Allowable Concentrations of Chemical Constituents In Uncontaminated Soil Used as Fill Material At Regulated Fill Operations (35 Ill. Adm. Code 1100 Subpart F)'. The one (1) soil sample from boring B-1, S-1 at 1'-2.5' depth was selected and sent to First Environmental Laboratories, Inc. located in Naperville, Illinois to perform VOCs, SVOCs, Total 8 RCRA Metals, and pH testing. The environmental chemical analysis results for the environmental sample were compared to the Maximum Allowable Concentration (MAC) for CCDD disposal analysis. The analytical results for the environmental soil samples are less than the MACs per 35 IAC 1100 Subpart F.

The result of the environmental chemical test and the applicable completed IEPA LPC-663 form has already been sent earlier as a separate letter report. Soil PID readings are shown on the project Core Boring Logs in the Appendix of this report

Screening of soil samples at the jobsite is no guarantee that landfill facility will accept/not reject materials since this report is prepared strictly on the basis of soil samples obtained from the soil borings only and it is not possible to determine if the site is entirely clean of contaminants per IEPA CCDD

standards. Environmental chemical analysis may be required if the soils at the time of excavation between the soil borings are found to be contaminated.

**Site Soil Conditions**

A total of four (4) pavement core borings (B-1 to B-4) were cored, drilled, and samples through the existing pavement section and subgrade soils to termination depths of 15 feet to 20 feet below the existing ground surface level. In general, the four (4) pavement core borings encountered approximately 1.5 inches to 1.75 inches of bituminous concrete pavement overlying approximately 6.5 inches to 7.5 inches of Portland Cement Concrete pavement base. The details of the pavement type and thicknesses of the surface course and pavement base encountered at these core borings are summarized in **Table No.1: Core Summary Table** below:

**Table No. 1- Core Summary Table**

<b>Core Boring No.</b>	<b>Approximate Bituminous Concrete Pavement Thickness (Inches)</b>		<b>Approximate PCC Base Thickness (Inches)</b>	<b>Remarks</b>
B-1	Surface	1.75	7.0	EOC @ 8.75 inches and core boring continued to 20 feet
B-2	Surface	1.5	7.5	EOC @ 9 inches and core boring continued to 20 feet
B-3	Surface	1.5	7.25	EOC @ 8.75 inches and core boring continued to 15 feet
B-4	Surface	1.5	6.5	EOC @ 8 inches and core boring continued to 15 feet
<b><u>AVERAGE=</u></b>		<b>1.56 inches</b>	<b>7.06 inches</b>	

EOC= End of Coring

Underlying the above mentioned pavement section, core borings (B-1 to B-4) generally encountered moist medium to stiff dark brown, brown, gray, black clay fill (A-6) to approximate depths of 1.5 feet to 3.5 feet below the existing ground surface level at each core boring location respectively. Underlying the clay fill soils, borings B-1 to B-4 generally encountered moist very stiff to hard brown and gray to brown virgin clay (A-6) to depth of 8.5 feet to 11 feet below the existing grade level, which is underlain by gray very stiff clay (A-6) to the termination depths of 15 feet to 20 feet below existing grade level.

It is recommended that the Coring Boring Logs given in the Appendix of this report should be studied for exact pavement and soil conditions at each boring/coring location.

#### **Site Groundwater Conditions**

Groundwater was not encountered in any of the core-borings (B-1 to B-4) to the termination depths of 15 feet to 20 feet below the existing ground surface elevation and was found in a dry condition while drilling, sampling, and removal of the hollow stem augers for this subsurface exploration by SEECO Consultants, Inc. on 5/31/19. However, yearly and seasonal fluctuations in the groundwater levels are possible due to changes in hydrogeological conditions at this site over time.

### **ENGINEERING ANALYSIS AND RESULTS**

#### **Storm Water Sewer and Water Main Recommendations**

Based on the pavement core borings and geotech laboratory testing of the subgrade soils for the installation of proposed 8-inch diameter DIP Class 52 water main and the proposed 12 inches to 21 inches diameter RCP storm sewer, it is recommended that the proposed water main and storm sewer should be installed at the project site using Open Cut Trench Excavation method with trench box protection at this project site.

The proposed 8 inch DIP water main will be installed at approximately 6.5 feet to 8.5 feet below the proposed pavement grade level which is generally bearing in brown and gray to brown, very stiff to hard virgin clay (A-6) soil which is suitable for bearing. Since clay glacial till soils were encountered within the four (4) pavement core borings drilled and sampled at this project location at the proposed approximate water main invert elevations, the silty clay glacial till soils generally have resistivity values of 500 to 1200 ohm – meters which is corrosive to ductile iron pipe. Therefore, it is recommended the proposed 8 inch diameter DIP water main should be wrapped with polyethylene wrap for corrosion protection. It is recommended to use polyethylene wrap due to the life cycle analysis in which polyethylene wrap lasts exponentially longer than manufacture zinc coatings according to Ductile Iron Pipe Association (DIPRA) research.

The proposed 12 inches to 21 inches RCP storm sewer will be generally installed at an invert depth of approximately 4 feet to 6.5 feet below proposed grade level which is generally bearing in brown and gray, very stiff to hard virgin clay (A-6) soil which are suitable for bearing.

The anticipated depth of excavation for the installation of proposed water main, storm sewer, and sanitary and storm manholes will be approximately 4 feet to 8.5 feet below the existing pavement grade level. Bedrock was not encountered in all four (4) pavement core borings for the entire drilling depths of 15 feet to 20 feet; therefore, bedrock excavation is not anticipated for the proposed water main and storm sewer installation. Refer to **Table No. 2** below for the sanitary sewer manholes MH-1 and MH-2 structure depth, net allowable bearing capacity, and hydrostatic uplift pressure foundation recommendations.

**Table No. 2 Sanitary Sewer Manhole Design**

Manhole No.	Adjacent Boring No.	Anticipated Rim Elevation of Proposed Manhole Structure (MSL)	Anticipated Invert of Proposed Manhole Structure (MSL)	Approximate Depth of Excavation (FT)	Anticipated Type of Soil at the Bottom of Excavation	Maximum Net Allowable Bearing Capacity at Bearing Depth (KSF)	Anticipated Hydrostatic Uplift Pressure* (PSF)
MH-1	B-1	681.14±	674.51±	6.63±	Brown and gray, very stiff, Clay, moist (A-6)	3.0	N/A
MH-2	B-4	681.83±	674.05±	7.78±	Brown, very stiff, Clay, moist (A-6)	3.0	N/A

N/A= Not Applicable

The soils at the bottom of the excavation for the proposed water main and storm sewer trenches and manholes in the vicinity of these four (4) pavement core borings (B-1 to B-4) are generally brown and gray to gray, very stiff to hard, virgin clay (A-6) soils. The pipe bedding material can be placed directly on these clay soils. Pipe bedding and trench backfill recommendations are provided later in this section.

#### **Braced Excavations for Water Main and Storm Water Sewer Construction**

Any excavation that extends greater than five (5) feet in depth should be designed in accordance with the U.S. Department of Labor, Occupational Safety and Health Administration 1989 (OSHA) "Occupational Safety and Health Standards – Excavations; Final Rule" 29 CFR, Part 1926 Subpart P. Since the proposed ductile iron water main and RCP storm sewers will be installed along Charles Avenue in Villa Park, Illinois to excavation depths of 4 feet to 8.5 feet which greater than 5 feet, the open cut excavation with vertical side walls will not be safe. Therefore, it is recommended that the trench excavations should be braced. The trench excavation with accompanying steel trench protection box should not have major problems when excavating for the proposed water main and/or storm sewers. The trench box is introduced into the trench and protects personnel in the trench and the

work under construction from damage or injury which might be caused by the collapse of the trench sidewalls. The trench box is designed to brace the two (2) parallel walls of the trench against each other. The walls of the box are constructed from sheet steel, usually double wall thickness, with a diaphragm between the two (2) sheets to provide structural rigidity. The pipe is laid inside the box after placing the bedding material and the men at the bottom of the trench join the pipe. The trench box is advanced as the excavation is dug and backfill material is placed.

The pre-fabricated steel trench protection box can be used for this project in order to protect personnel in the trench during construction and must conform to OSHA CFR 29, Part 1926, Subject P, July 1997, and the work under construction from damage or injury which might be caused by the collapse of the trench sidewalls.

The trench box should be designed for lateral earth pressure based on the apparent lateral earth pressure distribution for braced excavations based on Peck's criteria for stiff clay. The soil conditions at this project site are in general very stiff to hard cohesive glacial till soils and the minimum live load surcharge from construction equipment should be considered to be 600 psf per running foot of bracing. The depth of trenches for the proposed water main and storm sewer will vary, and will have anticipated approximate trench depths of 4 feet to 8.5 feet. Lateral earth pressure diagram is provided to 10 feet below the existing pavement surface level for possible deeper excavations. For trench excavations the steel trench box sidewalls and struts should be capable of resisting an approximate minimum of 820 psf per foot of length (for maximum 10 foot depth) of lateral earth pressure in comparison with the trench box allowable structural lateral pressure capacity. Refer to the **Apparent Lateral Earth Pressure Diagram For Trench Protection Box Design in Equivalent Clayey Soils (H ≤10 Feet Deep)** as given in the **Appendix** of this report. The utility contractor is responsible for the design of the trench protection box.

The parallel walls of the box are braced apart by adjustable pipe struts. The adjustment permits the use of the box in trenches of different widths. The box is open at both ends. The rear opening permits movement of the box along the trench while allowing passage of the completed pipe utility out of the back of the box. The front of the box is open to permit dragging the box forward through unstable ground. The top of the box is open to permit introduction of the pipe bedding and new portion of the pipe into the trench. The bottom of the box is open to permit placement of trench bedding directly on the bottom of the trench.

Trench boxes must not only be wide enough to permit the introduction of the required utility pipe or conduit together with the specified sidewall backfill cover, but also wide enough to permit passage of the backhoe bucket into the box to clean the base or bottom of the trench. Trench boxes are dragged forward by the backhoe (a hydraulic excavator) digging the trench on the front side. The backhoe hooks its bucket behind the leading pipe strut and pulls the box toward itself.

The stability of the bottom of trench excavation is controlled by the type of soil at the bottom of the trench and its underlying soils of the excavation trench. For the proposed water main and storm sewer, the bottom of an excavation in the brown and gray to gray, very stiff to hard, virgin clay soils should be stable for failure by plastic clay bottom heave since the bottom heave Factor of Safety should be greater than 1.5 for the proposed water main and storm sewer trench excavation. For conventional open cut and cover excavation construction, the following bedding and trench backfill recommendations are applicable:

#### **Manhole Structures and Pipe Bedding**

Bedding material should comply with Article 1003.04 of the IDOT Standard Specifications. The bedding material should be a well-graded granular material equivalent to IDOT FA-1, FA-2 or FA-6. A minimum 4.0 inches of bedding material is required to be placed below the water main pipe. The bedding

material must be placed in maximum 4.0 inch lifts and compacted to a minimum 95% of the maximum density according to AASHTO T-99. The placement of bedding material must comply with Article 550.04 of the IDOT Standard Specifications for Road and Bridge Construction, 2016 Edition.

### **Trench Backfill**

The silty clay cut material excavated from the water main and storm sewer trenches cannot be used as backfill for the trenches under driveways, roads or street pavements. The approved granular trench backfill material should be placed in maximum eight-inch loose lifts with each lift compacted to a minimum of 95% of maximum density as per AASHTO T-99 to the proposed subgrade of the street. Trench backfill material should be CA-6 stone of the IDOT Standard Specifications for Road and Bridge Construction, 2016 Edition. However, the final one foot of trench backfill should be compacted to 100% of maximum density as obtained according to AASHTO T-99. The excavation at any pavement areas should be completed with a bituminous concrete pavement section to match the proposed pavement section.

### **Cured-In-Place Pipe (CIPP) Lining**

The existing 10 inches diameter VCP Sanitary Sewer pipe will be spot repaired using CIPP (Cured In Place Pipe) lining for a total approximate length of 600 feet and sanitary sewer service connections at several locations will be removed and replaced. CIPP installation is widely used methods of trenchless pipeline renewal for both structural and nonstructural purpose and is usually used between manhole to manhole installations in sanitary sewers. The main components of CIPP are a flexible fabric tube and a thermosetting resin system in which the fabric tube carry and support the resin until it is installed and cured and the resin is the primary structural component of the system.

The initial setup consists of cleaning and televising of the pipeline and installation of flexible fabric tube with resin by either inversion or winched insertion method of installation and the flexible tube is forced by compressed air or water against the wall of the pipe to be rehabilitated. After the installation of

flexible tube and resin, curing of the resin is done by hot water, steam, or UV light. After curing, the new pipe is cooled and drained. The new pipe is of slightly smaller inside diameter and has a smooth interior surface which generally improves the flow capacity of the pipe by decreasing the gravity flow roughness factor "n".

The Cured-In-Place Pipe (CIPP) lining is usually suitable for all pipe shapes and pipe diameter greater than 6 inches and is a feasible method of lining for this project.

### **Full Depth Pavement Design and Construction Recommendations**

This project consists of approximately 1,245 linear feet of full depth total road reconstruction to the top of subgrade along Charles Avenue from St. Charles Road to Oak Street in the Village of Villa Park, Illinois. Based on the pavement core borings (B-1 to B-4) cored, drilled, and sampled along Charles Avenue, the subgrade soils encountered just below the existing pavement section consists of moist, dark brown, brown, gray and black, medium to stiff clay fill (A-6) soils which may be unsuitable for roadway construction and undercut may be needed based on proofroll inspection at the time of construction. Two (2) of the four (4) borings appear to require undercut which are borings B-1 and B-3 respectively due to low strength (approximately 0.75 tsf) and higher moisture contents (25% to 27%) in which this material may not pass a proofroll inspection. Therefore it is recommended to anticipate undercutting of these two (2) locations and adjacent areas.

Potential undercut Area #1 is located from approximate Station 101+92 to Station 103+90 (approximately 198 linear feet) taken from the project start to the approximate halfway point between borings B-1 and B-2 with a potential maximum undercut depth of 2 feet. The area should be undercut from back of curb to back of curb approximately 27 feet and should be undercut to the virgin very stiff brown and gray clay (A-6) at approximately 680.5 MSL. The proposed finish subgrade elevation is at approximately 682.5 MSL which gives a maximum undercut depth of approximately 2 feet from the

proposed finish subgrade elevation. The anticipated volume of potential undercut is approximately 396 cubic yards for this area adjacent to boring B-1.

Potential undercut Area #2 is located from approximate Station 107+45 to Station 111+25 (approximately 380 linear feet) taken from the approximate halfway point between borings B-2 and B-3 and also the approximate halfway point between borings B-3 and B-4. The area should be undercut from back of curb to back of curb approximately 27 feet and should be undercut to the virgin very stiff brown and gray clay (A-6) at approximately 675.5 MSL. The proposed finish subgrade elevation is at approximately 676.0 MSL which gives a maximum undercut depth of approximately 0.5 feet from the proposed finish subgrade elevation. The anticipated volume of potential undercut is approximately 190 cubic yards for this area adjacent to boring B-3. SEECO believes this area has a high probability to fail a proof roll because of the subgrade soils excessively wet moisture content.

The remaining subgrade sections estimated total length of 667 feet of the Charles Avenue should generally have stable subgrade passing a proof roll inspection and consist of Station 103+90 to Station 107+45 and Station 111+25 to Station 114+37 Refer to the following Pavement Site Preparation for the proof rolling methods and subgrade remedial actions.

**Pavement Site Preparation**

In order to prepare this pavement reconstruction project site, the following is recommended:

It is recommended that the existing bituminous concrete from the existing bituminous pavement of Charles Avenue total reconstruction pavement should be cold-milled off and trucked back to an asphalt batch plant for recycling. The existing Portland Cement Concrete base and concrete curb and gutter should be demolished and hauled off to concrete recycle plant for recycling. The existing crushed stone base course should be removed and legally disposed off-site.

Next, it is recommended to excavate to the proposed top of proposed finish subgrade elevation for the Charles Avenue total pavement reconstruction areas. It is recommended that in the area of any low/depressed areas where backfill may be needed to be placed for the preparation of subgrade, any existing water should be removed/pumped out (if needed) and any loose organic and inorganic sediment deposits collected in the low spots/depressions and any underlying soft soils must be removed before the structural fill is placed for the construction of new roadway subgrade.

After preparing the proposed pavement reconstruction areas at the site as mentioned above, the subgrade of all proposed new Charles Avenue full depth bituminous pavement areas should be proof rolled by using a rubber tire truck or tractor-trailer combination loaded with 20 tons of payload. For the preparation of subgrade if any subgrade areas of Charles Avenue areas do pump and rut during the proofroll inspection performed on the subgrade soils, then SEECO recommends to use remedial measures consisting of discing or scarifying up the subgrade soils and aerating them to dry them to a lower in situ moisture content (drying to within  $\pm 2\%$  of the optimum moisture content) and then recompacting these subgrade soils (if the construction is to be performed in hot and dry weather per methods). Once the remedial measures are performed (if needed), the subgrade soils can then be re-proofrolled in the presence of a Field Geotechnical Engineer to determine if these remediated subgrade soils are stable by passing the second proofroll inspection. If these subgrade soils fail the

proofroll after remedial measures, then SEECO Consultants Inc. recommends undercutting all the soft subgrade soils. The actual depths and lateral extent of the undercuts must be determined in the field by a Field Geotechnical Engineer from SEECO Consultants Inc. using a Static Cone Penetrometer (SCP) for clay soils and a Dynamic Cone Penetrometer (DCP) on cohesionless sand soils.

The undercut areas should be backfilled with coarse aggregate material to the proposed subgrade elevation. The type of coarse aggregate to be used for backfilling the undercut areas or raising the subgrade is given in the IDOT District One Special Provision **SECTION 303. AGGREGATE SUBGRADE IMPROVEMENT**, which is included in the **APPENDIX** of this report. Aggregate gradation for subgrade improvement is CS-01 or CS-02. The maximum nominal lift thickness of aggregate gradations CS-01 and CS-02 shall be 24 inches per IDOT specifications and the coarse aggregate material should be adequately rolled and compacted using a vibratory roller to achieve the desired keying or particle interlock and compaction of the granular fill in the subgrade to the satisfaction of the Engineer.

Undercutting per the requirements given in this geotech report should be performed by the earthwork subcontractor using a backhoe in the presence of the Field Geotechnical Engineer after the exact undercut depth and lateral extent is determined in the field by the Field Geotechnical Engineer with the use of a SCP or DCP per IDOT's Subgrade Stability Manual. The presence of the Field Geotechnical Engineer during undercutting is recommended for observation of the removal of the soils within the undercut depths, as well as to verify undercut quantities (horizontal and lateral limits). Alternatively, in the field if the SCP or DCP has to be utilized to determine possible depths of undercut then Tensar Geogrid TX160 or equivalent should be examined to determine if geogrid could be used to reduce undercut depth and to provide reinforcement as well as act as a separation barrier of materials at the bottom of the undercut and the granular refill material. See IDOT Subgrade Stability Manual for details.

Once the proposed design subgrade elevation is achieved, the subgrade should be adequately rolled with a steel drum roller. After rolling, the entire proposed new final design subgrade area should be proof rolled with a dump truck or tractor trailer loaded with a minimum 20 tons of payload before placing the crushed stone base course for the new proposed pavement areas.

### **Pavement Design**

The pavement design method of Illinois Department of Transportation (IDOT)- The Modified AASHTO Method can be utilized in the structural design of the flexible pavement. The following factors are usually taken into consideration in arriving at a design of a flexible pavement, traffic density and type of traffic and frequency (traffic count from traffic study) and design period of the proposed pavement. The traffic design information is necessary to determine the pavement design such as the distribution of single unit vehicles (SU), passenger vehicles (PV) and multiple unit vehicles (MU) along with the average daily traffic (ADT) count. The traffic study data should be obtained from a Traffic Consultant and the design of the pavement should be based on Chapter 54 'Pavement Design' of IDOT Bureau of Design and Environmental Manual, current edition. The Structural Number (SN) required for the design traffic can be used to calculate the right pavement thicknesses based on the proposed Structural Number (SN) from the assumed pavement design.

The full depth Hot Mix Asphalt (HMA) reconstruction should be designed based on an IBR value of 3 for the existing subgrade consisting of medium to stiff dark brown, brown, gray, black clay fill overlying very stiff to hard brown and gray clay as the encountered subgrade of existing Charles Avenue based on pavement core borings B-1 to B-4. The full depth HMA pavement should be designed according to the Village of Villa Park residential street design criteria and IDOT Chapter 54 of the Bureau of Design and Environment Manual.

Strand Associates, Inc. has proposed road pavement section consisting of 2 inches of Mix "D", N50 HMA surface course overlying 4 inches of N50 HMA Binder Course overlying a minimum 6 inches of compacted CA-6, Type B Crushed Stone as per IDOT "Standard Specifications for Road and Bridge Construction," 2016 Edition. This pavement section should be sufficient if the subgrade soils have been prepared as recommended above.

For the new proposed flexible pavement, the HMA surface course and HMA binder course should consist of bituminous concrete mixtures as defined in the State of Illinois "Standard Specifications for Road and Bridge Construction," Current Edition. The HMA surface course and HMA binder course should be compacted to a minimum 93% and maximum 97% theoretical density as determined by AASHTO T 209-19. This is the IDOT Big "D" value which is used with nuclear density testing of the asphalt in order to determine the percent of in-place compaction achieved in the field.

#### **Potential Construction Problems**

Groundwater was not encountered in any of the four (4) pavement core borings (B-1 to B-4) cored, drilled, and sampled to a depth of 15 feet to 20 feet below the existing pavement surface during this exploration of 5/31/2019. Therefore, groundwater problem should be minimum for the full depth reconstruction of the pavement areas and installation of proposed water main and storm sewer at this project site and any surface water collected in the trench excavations should be pumped out using standard sump and pump procedures.

Any excavation that extend greater than five feet in depth should be designed in accordance with U.S. Department of Labor, Occupational Safety and Health Administration 1989 (OSHA) "Occupational Safety and Health Standards-Excavations; Final Rule" 29 CFR, Part 1926, Subpart P. Excavations with properly sloped or braced excavation earth retention systems (such as trench boxes) to prevent excavation instability and provide safety is the responsibility of the utilities contractor. Also, the means

and methods of excavating the soil are at the discretion of the utilities contractor and are the responsibility of the utilities contractor.

**Construction Consultation Engineering**

A Field Geotechnical Engineer from SEECO Consultants Inc. should be present during the subgrade proofroll operations to document any undercut, utilities excavation operations to ensure compliance with the specifications during construction. Any deviation from the measured subsurface conditions and final surface ground elevations should be brought to the attention of the Geotechnical Engineer so that design parameters can be updated accordingly. Field density tests to determine the degree of trench backfill compaction should be performed by a Field Engineering Technician or Field Geotechnical Engineer from SEECO Consultants Inc. once the water main and storm sewer are installed and the backfilling begins. Also, a Field Engineering Technician or Field Geotechnical Engineer from SEECO Consultants Inc. should be present on site during construction to check the compaction of the new street base course and HMA lifts to verify compaction of these materials to plans and specifications.

Closing Remarks

We trust this report and the information contained herein is sufficient for your present requirements. We have welcomed the opportunity to be of service to you on this project. If there are any questions regarding this report, please contact us at your convenience.

Respectfully submitted,

SEECO Consultants, Inc.



Sandip Dahal, MSCE, EI  
Staff Geotechnical Engineer

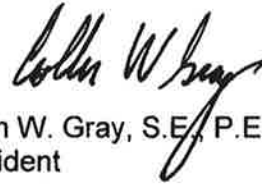

Collin W. Gray, S.E., P.E.  
President

SD:arm

I:\REPORTS\Geotech\PavementsRoads\12182G-Charles Ave -Villa Park,IL\12182G Final Revised 22520.doc

**APPENDIX**

1. **BORING LOCATION PLAN**
2. **GENERAL NOTES**
3. **CORE BORING LOGS**
4. **AASHTO SOIL CLASSIFICATION SYSTEM**
5. **APPARENT LATERAL EARTH PRESSURE DIAGRAM FOR TRENCH PROTECTION BOX DESIGN IN EQUIVALENT CLAYEY SOILS (H ≤10 FEET DEEP)**
6. **AGGREGATE SUBGRADE IMPROVEMENT (BDE)**

# **APPENDIX 1**

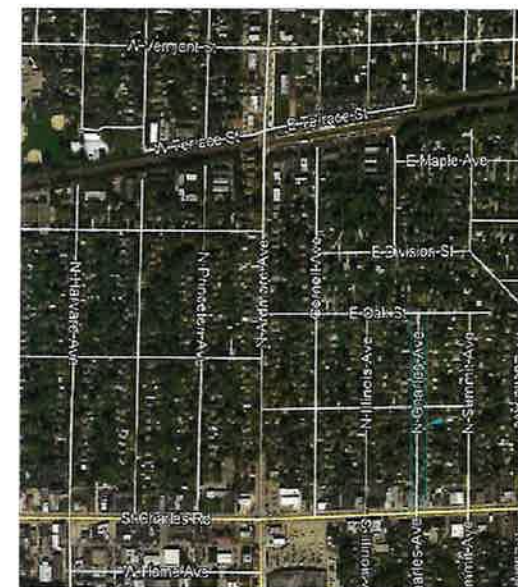
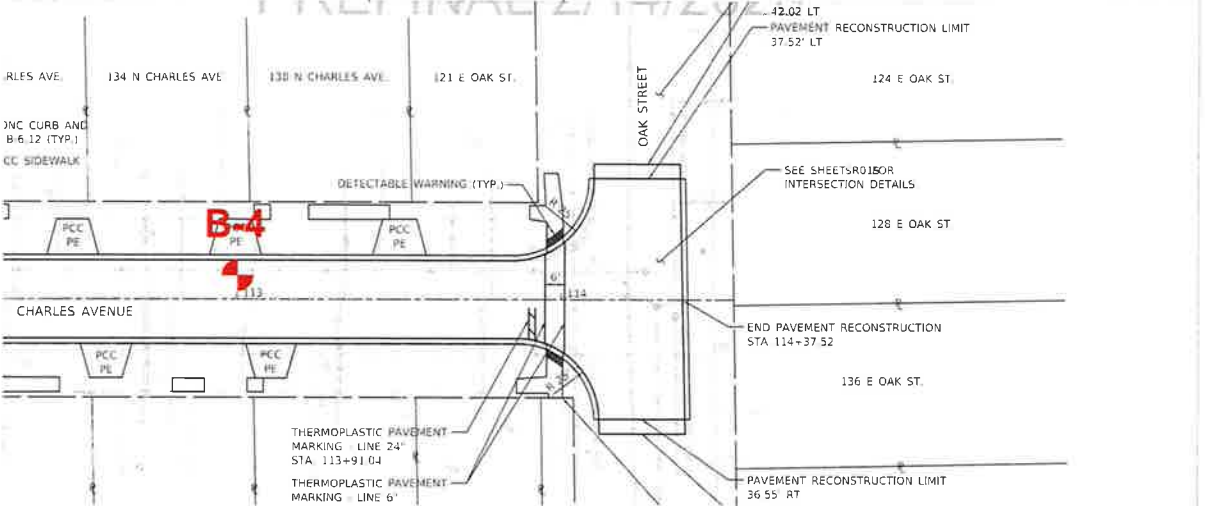
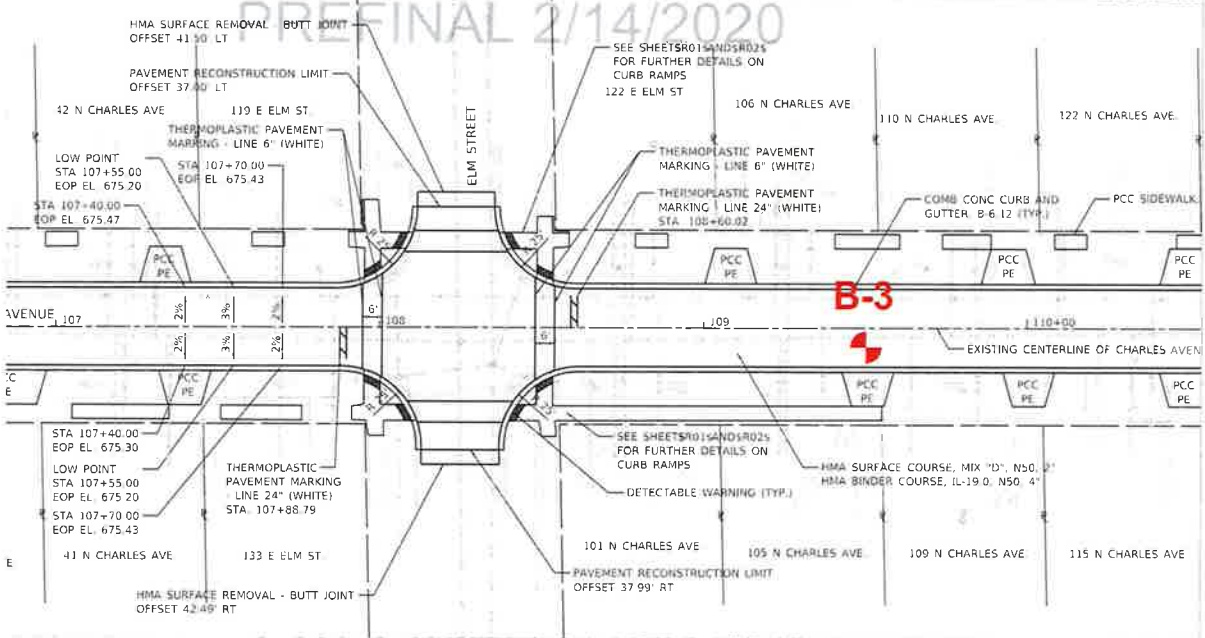
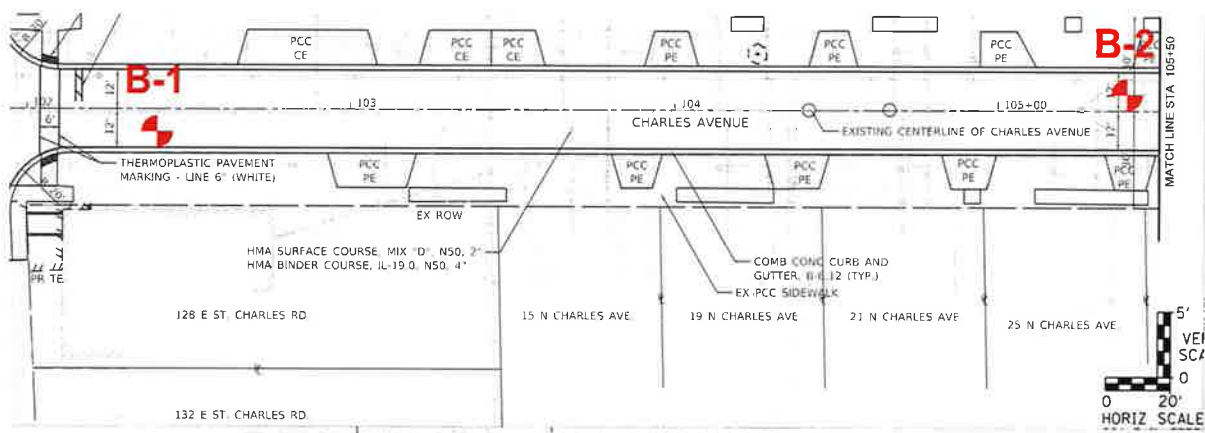

# **APPENDIX 2**

**SEECO Consultants Inc.**  
7350 DUVAN DRIVE  
TINLEY PARK, ILLINOIS 60477

GENERAL NOTES

DRILLING AND SAMPLING SYMBOLS

SS	SPLIT SPOON	1-3/8" I.D. x 2" O.D. (EXCEPT WHERE NOTED)
2T	THINWALL TUBE SAMPLER	2" O.D. x 1-7/8" I.D.
3T	THINWALL TUBE SAMPLER	3" O.D. x 2-7/8" I.D.
3P	PISTON SAMPLER	3" O.D. THINWALL TUBE
FA	CONTINUOUS FLIGHT AUGER	4" O.D.
HS	HOLLOW STEM AUGER	6-3/4" O.D. x 3-1/4" I.D.
HA	HAND AUGER	
RB	ROLLER ROCK BIT	
FT	FISHTAIL BIT	
DB	DIAMOND BIT	
AX	ROCK CORE	1-3/16" DIAMETER
BX	ROCK CORE	1-5/8" DIAMETER
NX	ROCK CORE	2-1/8" DIAMETER
AS	AUGER SAMPLE	
WS	WASH SAMPLE	
CA	COMBINED ANALYSIS	
SA	SIEVE ANALYSIS	

Standard "N" Penetration: Blows per foot of a 140 pound hammer falling 30 inches on a two inch O.D. split spoon, except where noted.

WATER LEVEL MEASUREMENT SYMBOLS

	WATER LEVEL OBSERVATION	WD	WHILE DRILLING
WCI	WET CAVE-IN	BCR	BEFORE CASING REMOVAL
DCI	DRY CAVE-IN	ACR	AFTER CASING REMOVAL
WS	WHILE SAMPLING	AB	AFTER BORING

Water levels indicated on the boring logs are the levels measured in the boring at the times indicated. In pervious soils, the indicated elevations are considered reliable groundwater levels. In impervious soils, the accurate determination of groundwater elevations are not possible in even several days observation, and additional evidence on groundwater elevations must be sought.

SOIL IDENTIFICATION TERMINOLOGY

COHESIONLESS SOILS

<u>COMPONENT</u>	<u>SIZE RANGE</u>	<u>DESCRIPTIVE TERM</u>	<u>PERCENT OF WEIGHT</u>
BOULDERS	OVER 8"	TRACE	0 - 10
COBBLES	8" TO 3"	LITTLE	10 - 20
GRAVEL	3" TO #4 SIEVE (4.75 mm)	SOME	20 - 35
SAND	#4 TO #200 SIEVE (0.074 mm)	AND	35 - 50
SILT	PASSING #200 SIEVE (0.074 mm)		

**SEECO Consultants Inc.**  
 7350 DUVAN DRIVE  
 TINLEY PARK, ILLINOIS 60477

**GENERAL NOTES**

**SOIL IDENTIFICATION TERMINOLOGY (Cont'd)**

**COHESIVE SOILS**

<u>DESCRIPTIVE TERM</u>	<u>PLASTICITY INDEX</u>
CLAYEY SILT OR ORGANIC CLAYEY SILT	4 – 7
SILTY CLAY OR ORGANIC SILTY CLAY	8 – 30
CLAY OR ORGANIC CLAY	> 30

**INTERMEDIATE SOILS**

<u>DESCRIPTIVE TERM</u>	<u>PLASTICITY INDEX</u>
SILT	0 – 3

Unconfined compression tests are generally not applicable for intermediate soils.

CONSISTENCY OF COHESIVE SOILS

RELATIVE DENSITY OF GRANULAR SOILS

1-3/8" I.D. x 2" O.D. with 140 pound hammer falling 30"

<u>UNCONFINED COMP. STRENGTH, Qu, TSF</u>	<u>CONSISTENCY</u>	<u>N – BLOWS/FT.</u>	<u>RELATIVE DENSITY</u>
<0.25	VERY SOFT	0 – 3	VERY LOOSE
0.25 - 0.49	SOFT	4 – 9	LOOSE
0.50 - 1.00	MEDIUM	10 – 29	MEDIUM DENSE
1.01 - 1.99	STIFF	30 – 49	DENSE
2.00 - 3.99	VERY STIFF	50 – 80	VERY DENSE
4.00 - 8.00	HARD	>80	EXTREMELY DENSE
>8.00	VERY HARD		

CONSISTENCY OF COHESIVE SOILS

<u>N – BLOWS/FT.</u>	<u>RELATIVE DENSITY</u>
0 – 2	VERY SOFT
2 – 4	SOFT
4 – 8	MEDIUM
8 – 15	STIFF
15 – 30	VERY STIFF
>30	HARD

**OWNER COPY**

**CONTRACT**

# **APPENDIX 3**

**BORING LOG**

CLIENT	<b>Strand Associates, Inc.</b>	PROJECT	<b>Charles Avenue Improvement Project</b>
OWNER	<b>Village of Villa Park</b>	LOCATION	<b>Charles Avenue, Villa Park, IL</b>

DEPTH ELEVATION	SAMPLE NO.	SAMPLER TYPE	SAMPLE REC. (%)	SOIL GRAPHIC LOG	BORING NUMBER	Unconfined Compressive Strength, Tons/Ft. <sup>2</sup>					REMARKS	
						1	2	3	4	5		
					<b>B-1</b>							
					SURFACE ELEVATION (M.S.L.)	<b>684.00+/-</b>						
					STATION	<b>102+39</b>				OFFSET from CL	<b>8' RT</b>	
					DESCRIPTION OF MATERIALS (LABORATORY CLASSIFICATION)							
0	1	SS	78	[Hatched Box]	1.75" BITUMINOUS CONCRETE PAVEMENT							Env. Sample
2.5		HS			7" PORTLAND CEMENT CONCRETE BASE							
2.5					FILL: CLAY, Dark Brown and Black, Some Brown, Trace Sand and Gravel, Medium, Moist (A-6)							
5.0	2	SS	89	[Hatched Box]	CLAY, Brown and Gray, Trace Sand and Gravel, Very Stiff, Moist (A-6)							
5.0		HS										
7.5	3	SS	44	[Hatched Box]								
7.5		HS										
10.0	4	SS	67	[Hatched Box]	CLAY, Brown, Trace Sand and Gravel, Very Stiff, Moist (A-6)							
10.0		HS										
12.5	5	SS	83	[Hatched Box]	CLAY, Gray, Trace Sand and Gravel, Very Stiff, Moist (A-6)							
12.5		HS										
15.0	6	SS	94	[Hatched Box]								
15.0		HS										
17.5	7	SS	56	[Hatched Box]								
17.5		HS										
20.0	8	SS	72	[Hatched Box]								
20.0		HS										
20.0					End of Boring at 20 Feet.							
22.5					Note:							
25.0					1) No Petroleum odors were observed in this boring utilizing olfactory senses. All the soil samples were screened with a MiniRae 3000 OVM photo-ionization device (PID) with all PID readings 0.0 ppm.							
					2) An environmental soil sample at S-1 (1' to 2.5') was obtained for environmental testing for pH, VOCs, SVOCs and total 8 RCRA metals.							

☉ Calibrated Penetrometer Unconfined Compression

Water Level Observations			<p align="center"><b>SEECO</b> <b>Consultants, Inc.</b></p> <p>7350 Duvan Drive, Tinley Park, IL 60477</p>	Boring Started	<b>5/31/19</b>
W.L.				Boring Completed	<b>5/31/19</b>
W.L.	<b>DRY WD/WS</b>	<b>DRY ACR</b>		Driller	<b>EN</b>
W.L.			Approved <b>MB</b>	Job No. <b>12182G</b>	Drawn By <b>NM</b>
					Sheet <b>1 of 1</b>







**OWNER COPY**

**CONTRACT**

**APPENDIX 4**

**IDOT SOIL CLASSIFICATION SYSTEM**

<b><u>GRAIN SIZE CLASSIFICATION</u></b>	<b><u>PERCENT BY WEIGHT</u></b>		
	<b><u>SAND</u></b>	<b><u>SILT</u></b>	<b><u>CLAY</u></b>
SAND	80-100	0-20	0-20
SANDY LOAM	50-80	0-50	0-20
LOAM	30-50	30-50	0-20
SILTY LOAM	0-50	50-80	0-20
SILT	0-20	80-100	0-20
SANDY CLAY LOAM	50-80	0-30	20-30
CLAY LOAM	20-50	20-50	20-30
SILTY CLAY LOAM	0-30	50-80	20-30
SANDY CLAY	50-70	0-20	30-50
SILTY CLAY	0-20	50-70	30-50
CLAY	0-50	0-50	30-100

**AASHTO SOIL CLASSIFICATION SYSTEM**

<b><u>General Classification</u></b>	<b><u>Granular Materials (35% or Less Passing No. 200)</u></b>							<b><u>Silt-Clay Materials (More than 35% Passing No. 200)</u></b>			
	<b><u>A-1</u></b>		<b><u>A-2</u></b>					<b><u>A-7</u></b>			
<b><u>Group Classification</u></b>	<b><u>A-1-a</u></b>	<b><u>A-1-b</u></b>	<b><u>A-3</u></b>	<b><u>A-2-4</u></b>	<b><u>A-2-5</u></b>	<b><u>A-2-6</u></b>	<b><u>A-2-7</u></b>	<b><u>A-4</u></b>	<b><u>A-5</u></b>	<b><u>A-6</u></b>	<b><u>A-7-5 A-7-6</u></b>
Sieve analysis, percent passing:											
No. 10	50 max.	---	---	---	---	---	---	---	---	---	---
No. 40	30 max.	50 max.	51 min.	---	---	---	---	---	---	---	---
No. 200	15 max.	25 max.	10 max.	35 max.	35 max.	35 max.	35 max.	36 min.	36 min.	36 min.	36 min.
Characteristics of fraction passing No. 40:											
Liquid Limit	---	---	---	40 max.	41 min.	40 max.	41 min.	40 max.	41 min.	40 max.	41 min.
Plasticity Index	6 max.	N.P.	N.P.	10 max.	10 max.	11 min.	11 min.	10 max.	10 max.	11 min.	11 min.*
Usual types of significant constituent materials	Stone fragments, gravel and sand		Fine sand	Silty or clayey gravel and sand			Silty soils		Clayey soils		
General rating as subgrade	Excellent to good							Fair to poor			

\*Plasticity index of A-7-5 subgroup is equal to or less than LL minus 30. Plasticity index of A-7-6 subgroup is greater than LL minus 30.

General Classification	Granular Materials (35% or Less of Total Sample Passing No. 200)						Silt-Clay Materials (More than 35% of Total Sample Passing No. 200)					
	A-1		A-3	A-2			A-4	A-5	A-6	A-7		
Group Classification	A-1-a	A-1-b	A-2-4	A-2-5	A-2-6	A-2-7				A-7-5* A-7-6		
Sieve analysis												
percent passing:												
No. 10	50 max.		51 min.		35 max.		36 min.		36 min.		36 min.	
No. 40	30 max.	50 max.	51 min.	35 max.	35 max.	35 max.	35 max.	36 min.	36 min.	36 min.	36 min.	
No. 200	15 max.	25 max.	10 max.	35 max.	35 max.	35 max.	35 max.	36 min.	36 min.	36 min.	36 min.	
Characteristics of fraction passing No. 40:												
Liquid limit	---		---		40 max.	41 min.	40 max.	41 min.	40 max.	41 min.	40 max.	41 min.
Plastic index	6 max.		NP		10 max.	10 max.	11 min.	11 min.	10 max.	10 max.	11 min.	11 min.
Significant constituent materials	Gravel and sand		Fine sand		Silty and clayey gravel and sand			Silty soils		Clayey soils		

(a) AASHTO Soil Classification System soil groups. A-8 (not shown) is peat or muck classified visually.

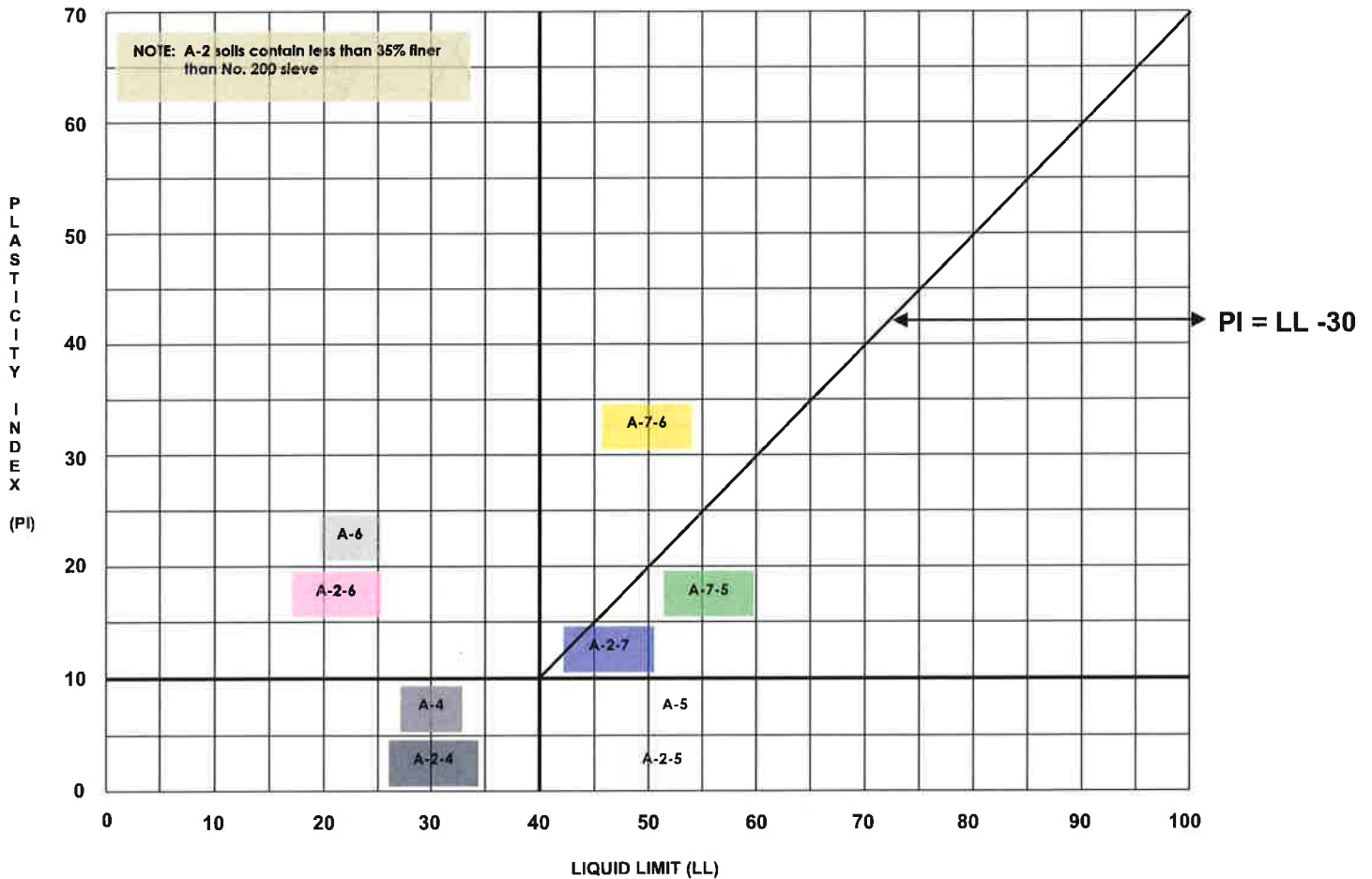

(b) Liquid Limit and plasticity index ranges for group classification of silt-clay materials. (Standard Specifications for Transportation Materials and Methods of Sampling and Testing, 27th ed., Washington, DC, American Association of State Highway and Transportation Officials, Copyright 2007. Used by permission.

Charts for use in AASHTO Soil Classification System.

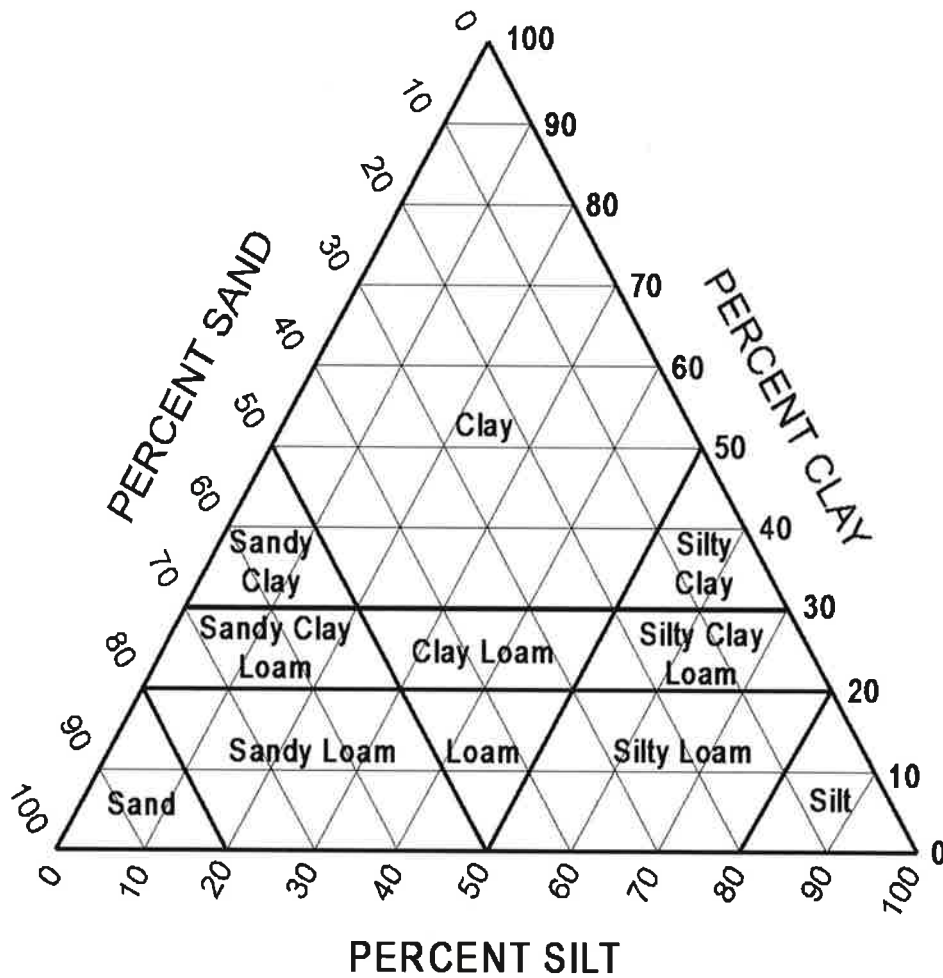

SIZE LIMITS		
SAND: 2.0 to 0.075 mm	SILT: 0.075 to 0.002 mm	CLAY: Below 0.002 mm

Figure 5.5.5.1-1 IDH Textural Classification Chart

# **APPENDIX 5**

# Apparent Lateral Earth Pressure Diagram For Trench Protection Box Design in Equivalent Clayey Soils (H ≤ 15 Feet Deep)

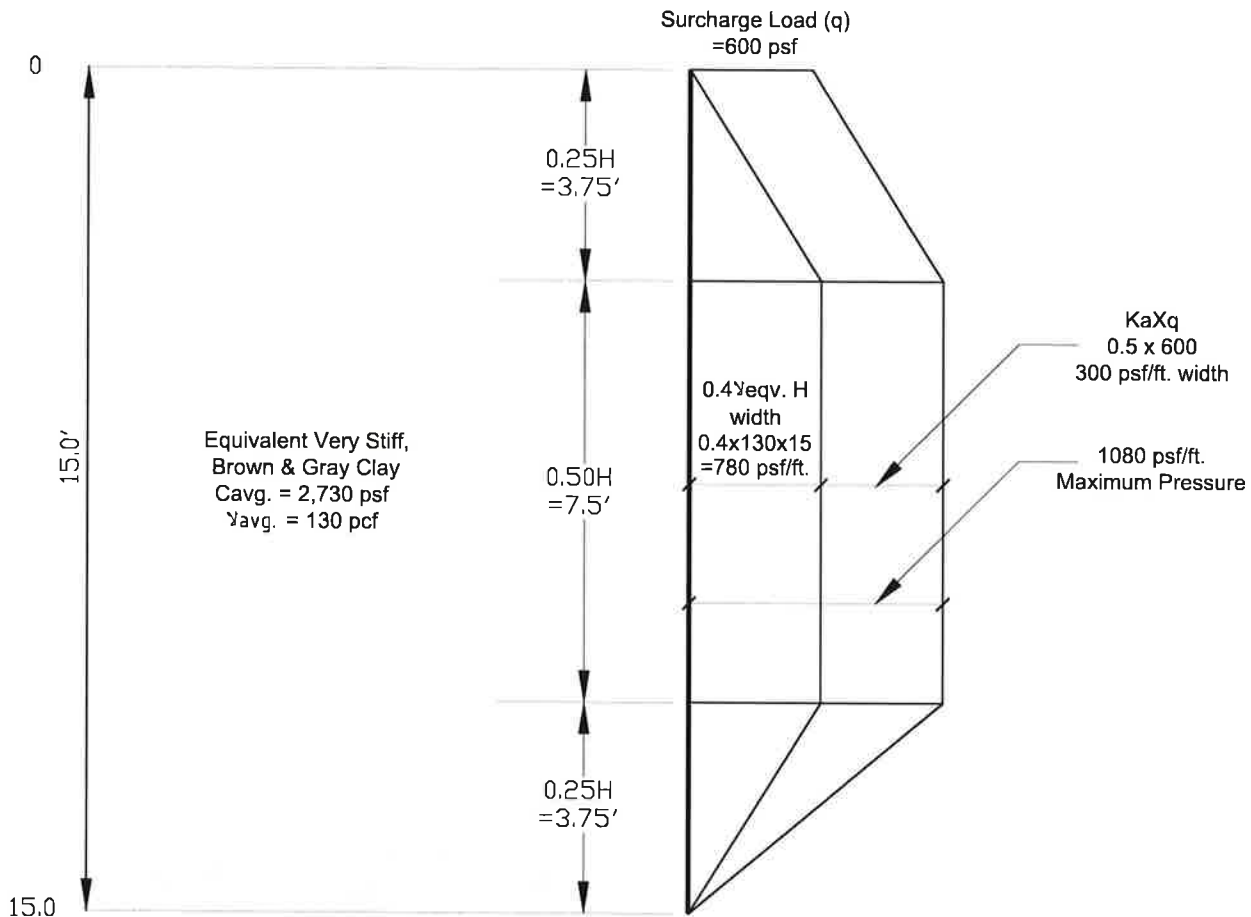

Note: Pressure Diagram for a braced excavation through the silty clay is determined by equilibrium and by assuming the area is prede-watered to the bottom of the excavation.

Cavg. = 2730 psf & γ avg. = 130 pcf  
 $\gamma_{avg} \cdot H / C_{avg} = (130 \text{ pcf} \cdot 15') / 2730 \text{ psf} = 0.71 < 4.0$

$\sigma_a = 0.4\gamma_{eqv} \cdot H + K_a \cdot q$   
 $= 0.4(130)(15) + 0.50 \cdot 600$   
 $= 1080 \text{ psf/ft.}$

Assumptions: 1) Water table is below the bottom of excavation.

DRAWN BY NM	APPROVED CWG	DATE 6/5/19	APPARENT LATERAL BRACED EARTH PRESSURE DIAGRAM FOR TRENCH PROTECTION BOX DESIGN IN COHESIVE SOILS
SCALE N.T.S.	FIGURE 1 OF 1	JOB NO. 12182G	CLIENT Strand Associates, Inc.
 <b>SEECO Consultants, Inc.</b> 7350 Duwan Drive, Tinley Park, Illinois 60477 OFFICE: (708) 429-1666 FAX: (708) 429-1689			PROJECT NAME & LOCATION Proposed Charles Avenue Improvement Project Charles Avenue, Villa Park, IL

# **APPENDIX 6**



# Illinois Department of Transportation

## Memorandum

---

To: Regional Engineers  
From: Omer M. Osman *Osman, Omer*  
Subject: Special Provision for Aggregate Subgrade Improvement  
Date: January 8, 2016

---

This special provision was developed by the Bureau of Materials and Physical Research to allow the use of gravel in fills over 24 inches in thickness. This special provision has been revised to fit with the 2016 Standard Specifications.

The designer should check with the District Geotechnical Engineer to determine the appropriate thickness of the aggregate subgrade material.

When this special provision is used, BDE special provision, Reclaimed Asphalt Pavement and Reclaimed Asphalt Shingles should also be included in the contract.

It should be included in all contracts utilizing aggregate subgrade improvements.

The districts should include the BDE Check Sheet marked with the applicable special provisions for the April 22, 2016 and subsequent lettings. The Project Development and Implementation Section will include a copy in the contract.

This special provision will be available on the transfer directory January 8, 2016.

80274m

**AGGREGATE SUBGRADE IMPROVEMENT (BDE)**

Effective: April 1, 2012

Revised: April 1, 2016

Add the following Section to the Standard Specifications:

**"SECTION 303. AGGREGATE SUBGRADE IMPROVEMENT**

**303.01 Description.** This work shall consist of constructing an aggregate subgrade improvement.

**303.02 Materials.** Materials shall be according to the following.

Item	Article/Section
(a) Coarse Aggregate .....	1004.07
(b) Reclaimed Asphalt Pavement (RAP) (Notes 1, 2, and 3) .....	1031

Note 1. Crushed RAP, from either full depth or single lift removal, may be mechanically blended with aggregate gradations CS 01, CS 02, and RR 01 but shall not exceed 40 percent of the total product. The top size of the RAP shall be less than 4 in. (100 mm) and well graded.

Note 2. RAP having 100 percent passing the 1 1/2 in. (37.5 mm) sieve and being well graded, may be used as capping aggregate in the top 3 in. (75 mm) when aggregate gradations CS 01, CS 02, or RR 01 are used in lower lifts.

Note 3. The RAP used for aggregate subgrade improvement shall be according to the current Bureau of Materials and Physical Research Policy Memorandum, "Reclaimed Asphalt Pavement (RAP) for Aggregate Applications".

**303.03 Equipment.** The vibratory machine shall be according to Article 1101.01, or as approved by the Engineer.

**303.04 Soil Preparation.** The stability of the soil shall be according to the Department's Subgrade Stability Manual for the aggregate thickness specified.

**303.05 Placing Aggregate.** The maximum nominal lift thickness of aggregate gradations CA 02, CA 06, or CA 10 shall be 12 in. (300 mm). The maximum nominal lift thickness of aggregate gradations CS 01, CS 02, and RR 01 shall be 24 in. (600 mm).

**303.06 Capping Aggregate.** The top surface of the aggregate subgrade shall consist of a minimum 3 in. (75 mm) of aggregate gradations CA 06 or CA 10. When the contract specifies that a granular subbase is to be placed on the aggregate subgrade improvement, the 3 in. (75 mm) of capping aggregate shall be the same gradation and may be placed with the underlying aggregate subgrade improvement material.

**303.07 Compaction.** All aggregate lifts shall be compacted to the satisfaction of the Engineer. If the moisture content of the material is such that compaction cannot be obtained, sufficient water shall be added so that satisfactory compaction can be obtained.

**303.08 Finishing and Maintenance of Aggregate Subgrade Improvement.** The aggregate subgrade improvement shall be finished to the lines, grades, and cross sections shown on the plans, or as directed by the Engineer. The aggregate subgrade improvement shall be maintained in a smooth and compacted condition.

**303.09 Method of Measurement.** This work will be measured for payment according to Article 311.08.

**303.10 Basis of Payment.** This work will be paid for at the contract unit price per cubic yard (cubic meter) or ton (metric ton) for AGGREGATE SUBGRADE IMPROVEMENT or at the contract unit price per square yard (square meter) for AGGREGATE SUBGRADE IMPROVEMENT, of the thickness specified."

Add the following to Section 1004 of the Standard Specifications:

**1004.07 Coarse Aggregate for Aggregate Subgrade Improvement.** The aggregate shall be according to Article 1004.01 and the following.

- (a) Description. The coarse aggregate shall be crushed gravel, crushed stone, or crushed concrete. In applications where greater than 24 in. (600 mm) of subgrade material is required, gravel may be used below the first 12 in (300 mm) of subgrade.
- (b) Quality. The coarse aggregate shall consist of sound durable particles reasonably free of deleterious materials.
- (c) Gradation.
  - (1) The coarse aggregate gradation for total subgrade thickness less than or equal to 12 in. (300 mm) shall be CA 2, CA 6, CA 10, or CS 01.

The coarse aggregate gradation for total subgrade thickness more than 12 in. (300 mm) shall be CS 01 or CS 02 as shown below or RR 01 according to Article 1005.01(c).

COARSE AGGREGATE SUBGRADE GRADATIONS					
Grad No.	Sieve Size and Percent Passing				
	8"	6"	4"	2"	#4
CS 01	100	97 ± 3	90 ± 10	45 ± 25	20 ± 20
CS 02		100	80 ± 10	25 ± 15	

COARSE AGGREGATE SUBGRADE GRADATIONS (Metric)					
---	--	--	--	--	--

Grad No.	Sieve Size and Percent Passing				
	200 mm	150 mm	100 mm	50 mm	4.75 mm
CS 01	100	97 ± 3	90 ± 10	45 ± 25	20 ± 20
CS 02		100	80 ± 10	25 ± 15	

(2) The 3 in. (75 mm) capping aggregate shall be gradation CA 6 or CA 10."

80274



# Illinois Environmental Protection Agency

1021 North Grand Avenue East • P.O. Box 19276 • Springfield • Illinois • 62794-9276 • (217) 782-3397

## Uncontaminated Soil Certification by Licensed Professional Engineer or Licensed Professional Geologist for Use of Uncontaminated Soil as Fill in a CCDD or Uncontaminated Soil Fill Operation LPC-663

Revised in accordance with 35 Ill. Adm. Code 1100, as amended by PCB R2012-009 (eff. Aug. 27, 2012)

This certification form is to be used by professional engineers and professional geologists to certify, pursuant to 35 Ill. Adm. Code 1100.205(a)(1)(B), that soil (i) is uncontaminated soil and (ii) is within a pH range of 6.26 to 9.0. If you have questions about this form, please telephone the Bureau of Land Permit Section at 217/524-3300.

This form may be completed online, saved locally, printed and signed, and submitted to prospective clean construction or demolition debris (CCDD) fill operations or uncontaminated soil fill operations.

### I. Source Location Information

(Describe the location of the source of the uncontaminated soil)

Project Name: Proposed Charles Ave. Improvement Project Office Phone Number, if available: \_\_\_\_\_

Physical Site Location (address, including number and street):

N. Charles Avenue - From St. Charles Road to Oak Street

City: Villa Park State: IL Zip Code: 60181

County: DuPage Township: Addison

Lat/Long of approximate center of site in decimal degrees (DD.ddddd) to five decimal places (e.g., 40.67890, -90.12345):

Latitude: 41.89164 Longitude: - 87.97512

(Decimal Degrees)

(-Decimal Degrees)

Identify how the lat/long data were determined:

GPS  Map Interpolation  Photo Interpolation  Survey  Other

IEPA Site Number(s), if assigned: BOL: \_\_\_\_\_ BOW: \_\_\_\_\_ BOA: \_\_\_\_\_

Approximate Start Date (mm/dd/yyyy): \_\_\_\_\_ Approximate End Date (mm/dd/yyyy): \_\_\_\_\_

Estimated Volume of debris (cu. Yd.): \_\_\_\_\_

### II. Owner/Operator Information for Source Site

Site Owner

Name: Village of Villa Park

Street Address: 11 West Home Avenue

PO Box: \_\_\_\_\_

City: Villa Park State: IL

Zip Code: 60181 Phone: 630-834-8505

Contact: Rich Salerno Public Works Director

Email, if available: \_\_\_\_\_

Site Operator

Name: Village of Villa Park

Street Address: 11 West Home Avenue

PO Box: \_\_\_\_\_

City: Villa Park State: IL

Zip Code: 60181 Phone: 630-834-8505

Contact: Rich Salerno Public Works Director

Email, if available: \_\_\_\_\_

This Agency is authorized to require this information under Section 4 and Title X of the Environmental Protection Act (415 ILCS 5/4, 5/39). Failure to disclose this information may result in: a civil penalty of not to exceed \$50,000 for the violation and an additional civil penalty of not to exceed \$10,000 for each day during which the violation continues (415 ILCS 5/42). This form has been approved by the Forms Management Center.

Uncontaminated Soil Certification

**III. Basis for Certification and Attachments**

For each item listed below, reference the attachments to this form that provide the required information.

a. A Description of the soil sample points and how they were determined to be sufficient in number and appropriately located 35 Ill. Adm. Code 1100.610(a):

Sampled 4 representative locations (B-1 to B-4). The project site is a residential area and B1/S1 was tested. Materials certified herewith as CCDD material must be free of odors, rebar, garbage, etc. and any said materials must be segregated from CCDD materials and disposed of in other legal means.

b. Analytical soil testing results to show that soil chemical constituents comply with the maximum allowable concentrations established pursuant to 35 Ill. Adm. Code Part 1100, Subpart F and that the soil pH is within the range of 6.25 to 9.0, including the documentation of chain of custody control, a copy of the lab analysis; the accreditation status of the laboratory performing the analysis; and certification by an authorized agent of the laboratory that the analysis has been performed in accordance with the Agency's rules for the accreditation of environmental and the scope of the accreditation [35 Ill. Adm. Code 1100.201(g), 1100.205(a), 1100.610]:

SEECO screened for volatile organic vapors with a PID and all samples indicated 0.0ppm. B1/S1 sample was tested and laboratory analysis met MAC table requirements.

**IV. Certification Statement, Signature and Seal of Licensed Professional Engineer or Licensed Professional Geologist**

I, Matthew Boladz, PE (name of licensed professional engineer or geologist) certify under penalty of law that the information submitted, including but not limited to, all attachments and other information, is to the best of my knowledge and belief, true, accurate and complete. In accordance with the Environmental Protection Act [415 ILCS 5/22.51 or 22.51a] and 35 Ill. Adm. Code 1100.205(a), I certify that the soil from this site is uncontaminated soil. I also certify that the soil pH is within the range of 6.25 to 9.0. In addition, I certify that the soil has not been removed from the site as part of a cleanup or removal of contaminants. All necessary documentation is attached.

***Any person who knowingly makes a false, fictitious, or fraudulent material statement, orally or in writing, to the Illinois EPA commits a Class 4 felony. A second or subsequent offense after conviction is a Class 3 felony. (415 ILCS 5/44(h))***

Company Name: SEECO Environmental Services, Inc.  
Street Address: 7350 Duvan Drive  
City: Tinley Park State: IL Zip Code: 60477  
Phone: 708-429-1685

Matthew Boladz, PE  
Printed Name:

  
Licensed Professional Engineer or  
Licensed Professional Geologist Signature:

Jun 20, 2019  
Date:

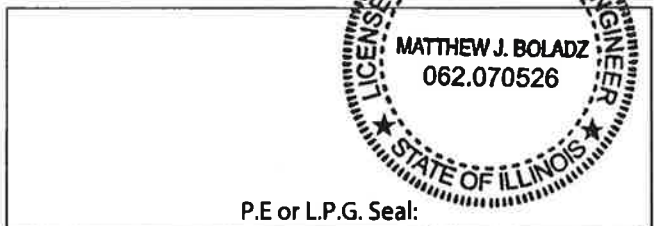

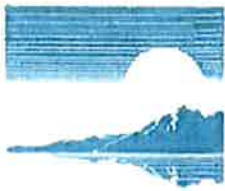

**First  
Environmental  
Laboratories, Inc.**

IL ELAP / NELAC Accreditation # 100292

1600 Shore Road • Naperville, Illinois 60563 • Phone (630) 778-1200 • Fax (630) 778-1233

June 19, 2019

Mr. Don Cassier  
**SEECO ENVIRONMENTAL SERVICES**  
7350 Duvan Drive  
Tinley Park, IL 60477

Project ID: 12182  
First Environmental File ID: 19-3587  
Date Received: June 13, 2019

Dear Mr. Don Cassier:

The above referenced project was analyzed as directed on the enclosed chain of custody record.

All Quality Control criteria as outlined in the methods and current IL ELAP/NELAP have been met unless otherwise noted. QA/QC documentation and raw data will remain on file for future reference. Our accreditation number is 100292 and our current certificate is number 004598; effective 04/23/2019 through 02/28/2020.

I thank you for the opportunity to be of service to you and look forward to working with you again in the future. Should you have any questions regarding any of the enclosed analytical data or need additional information, please contact me at (630) 778-1200.

Sincerely,



Stan Zaworski  
Project Manager



**First  
Environmental  
Laboratories, Inc.**

IL ELAP / NELAC Accreditation # 100292

1600 Shore Road • Naperville, Illinois 60563 • Phone (630) 778-1200 • Fax (630) 778-1233

### Case Narrative

**SEECO ENVIRONMENTAL SERVICES**

Lab File ID: **19-3587**

Project ID: **12182**

Date Received: **June 13, 2019**

All quality control criteria, as outlined in the methods, have been met except as noted below or on the following analytical report.

The results in this report apply to the samples in the following table:

Laboratory Sample ID	Client Sample Identifier	Date/Time Collected
19-3587-001	B-1 S-1	06/08/19

**Sample Batch Comments:**

Method 5035 vials for soil VOCs were not received. Samples preserved in lab.

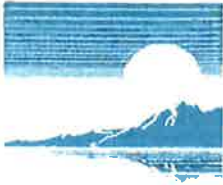

**First  
Environmental  
Laboratories, Inc.**

IL ELAP / NELAC Accreditation # 100292

1600 Shore Road • Naperville, Illinois 60563 • Phone (630) 778-1200 • Fax (630) 778-1233

### Case Narrative

**SEECO ENVIRONMENTAL SERVICES**

Lab File ID: **19-3587**

Project ID: **12182**

Date Received: **June 13, 2019**

All quality control criteria, as outlined in the methods, have been met except as noted below or on the following analytical report.

The following is a definition of flags that may be used in this report:

Flag	Description	Flag	Description
A	Method holding time is 15 minutes from collection. Lab analysis was performed as soon as possible.		
B	Analyte was found in the method blank.	L	LCS recovery outside control limits.
<	Analyte not detected at or above the reporting limit.	M	MS recovery outside control limits; LCS acceptable.
C	Sample received in an improper container for this test.	P	Chemical preservation pH adjusted in lab.
D	Surrogates diluted out; recovery not available.	Q	Result was determined by a GC/MS database search.
E	Estimated result; concentration exceeds calibration range.	S	Analysis was subcontracted to another laboratory.
G	Surrogate recovery outside control limits.	T	Result is less than three times the MDL value.
H	Analysis or extraction holding time exceeded.	W	Reporting limit elevated due to sample matrix.
J	Estimated result, concentration is less than routine RL but greater than MDL.	N	Analyte is not part of our NELAC accreditation or accreditation may not be available for this parameter.
RI.	Routine Reporting Limit (Lowest amount that can be detected when routine weights/volumes are used without dilution.)	ND	Analyte was not detected using a library search routine; No calibration standard was analyzed.



**First  
Environmental  
Laboratories, Inc.**

IL ELAP / NELAC Accreditation # 100292

1600 Shore Road • Naperville, Illinois 60563 • Phone (630) 778-1200 • Fax (630) 778-1233

**Analytical Report**

**Client:** SEECO ENVIRONMENTAL SERVICES  
**Project ID:** 12182  
**Sample ID:** B-1 S-1  
**Sample No:** 19-3587-001

**Date Collected:** 06/08/19  
**Time Collected:**  
**Date Received:** 06/13/19  
**Date Reported:** 06/19/19

Results are reported on a dry weight basis.

Analyte	Result	R.L.	Units	Flags
<b>Solids, Total</b>				
<b>Method: 2540B</b>				
Analysis Date: 06/14/19				
Total Solids	91.16		%	
<b>Volatile Organic Compounds</b>				
<b>Method: 5035A/8260B</b>				
Analysis Date: 06/17/19				
Acetone	< 200	200	ug/kg	
Benzene	< 5.0	5.0	ug/kg	
Bromodichloromethane	< 5.0	5.0	ug/kg	
Bromoform	< 5.0	5.0	ug/kg	
Bromomethane	< 10.0	10.0	ug/kg	
2-Butanone (MEK)	< 100	100	ug/kg	
Carbon disulfide	< 5.0	5.0	ug/kg	
Carbon tetrachloride	< 5.0	5.0	ug/kg	
Chlorobenzene	< 5.0	5.0	ug/kg	
Chlorodibromomethane	< 5.0	5.0	ug/kg	
Chloroethane	< 10.0	10.0	ug/kg	
Chloroform	< 5.0	5.0	ug/kg	
Chloromethane	< 10.0	10.0	ug/kg	
1,1-Dichloroethane	< 5.0	5.0	ug/kg	
1,2-Dichloroethane	< 5.0	5.0	ug/kg	
1,1-Dichloroethene	< 5.0	5.0	ug/kg	
cis-1,2-Dichloroethene	< 5.0	5.0	ug/kg	
trans-1,2-Dichloroethene	< 5.0	5.0	ug/kg	
1,2-Dichloropropane	< 5.0	5.0	ug/kg	
cis-1,3-Dichloropropene	< 4.0	4.0	ug/kg	
trans-1,3-Dichloropropene	< 4.0	4.0	ug/kg	
Ethylbenzene	< 5.0	5.0	ug/kg	
2-Hexanone	< 10.0	10.0	ug/kg	
Methyl-tert-butylether (MTBE)	< 5.0	5.0	ug/kg	
4-Methyl-2-pentanone (MIBK)	< 10.0	10.0	ug/kg	
Methylene chloride	< 20.0	20.0	ug/kg	
Styrene	< 5.0	5.0	ug/kg	
1,1,2,2-Tetrachloroethane	< 5.0	5.0	ug/kg	
Tetrachloroethene	< 5.0	5.0	ug/kg	
Toluene	< 5.0	5.0	ug/kg	
1,1,1-Trichloroethane	< 5.0	5.0	ug/kg	
1,1,2-Trichloroethane	< 5.0	5.0	ug/kg	
Trichloroethene	< 5.0	5.0	ug/kg	



**First  
Environmental  
Laboratories, Inc.**

1600 Shore Road • Naperville, Illinois 60563 • Phone (630) 778-1200 • Fax (630) 778-1233

IL ELAP / NELAC Accreditation # 100292

### Analytical Report

**Client:** SEECO ENVIRONMENTAL SERVICES  
**Project ID:** 12182  
**Sample ID:** B-1 S-1  
**Sample No:** 19-3587-001

**Date Collected:** 06/08/19  
**Time Collected:**  
**Date Received:** 06/13/19  
**Date Reported:** 06/19/19

Results are reported on a dry weight basis.

Analyte	Result	R.L.	Units	Flags
<b>Volatile Organic Compounds</b>		<b>Method: 5035A/8260B</b>		
Analysis Date: 06/17/19				
Vinyl acetate	< 10.0	10.0	ug/kg	
Vinyl chloride	< 10.0	10.0	ug/kg	
Xylene, Total	< 5.0	5.0	ug/kg	
<b>Semi-Volatile Compounds</b>		<b>Method: 8270C</b>		<b>Preparation Method 3540C</b>
Analysis Date: 06/14/19				
Preparation Date: 06/13/19				
Acenaphthene	< 330	330	ug/kg	
Acenaphthylene	< 330	330	ug/kg	
Anthracene	< 330	330	ug/kg	
Benzidine	< 330	330	ug/kg	
Benzo(a)anthracene	< 330	330	ug/kg	
Benzo(a)pyrene	< 90	90	ug/kg	
Benzo(b)fluoranthene	< 330	330	ug/kg	
Benzo(k)fluoranthene	< 330	330	ug/kg	
Benzo(ghi)perylene	< 330	330	ug/kg	
Benzoic acid	< 330	330	ug/kg	
Benzyl alcohol	< 330	330	ug/kg	
bis(2-Chloroethoxy)methane	< 330	330	ug/kg	
bis(2-Chloroethyl)ether	< 330	330	ug/kg	
bis(2-Chloroisopropyl)ether	< 330	330	ug/kg	
bis(2-Ethylhexyl)phthalate	< 330	330	ug/kg	
4-Bromophenyl phenyl ether	< 330	330	ug/kg	
Butyl benzyl phthalate	< 330	330	ug/kg	
Carbazole	< 330	330	ug/kg	
4-Chloroaniline	< 330	330	ug/kg	
4-Chloro-3-methylphenol	< 330	330	ug/kg	
2-Chloronaphthalene	< 330	330	ug/kg	
2-Chlorophenol	< 330	330	ug/kg	
4-Chlorophenyl phenyl ether	< 330	330	ug/kg	
Chrysene	< 330	330	ug/kg	
Dibenzo(a,h)anthracene	< 90	90	ug/kg	
Dibenzofuran	< 330	330	ug/kg	
1,2-Dichlorobenzene	< 330	330	ug/kg	
1,3-Dichlorobenzene	< 330	330	ug/kg	
1,4-Dichlorobenzene	< 330	330	ug/kg	
3,3'-Dichlorobenzidine	< 660	660	ug/kg	
2,4-Dichlorophenol	< 330	330	ug/kg	



**First  
Environmental  
Laboratories, Inc.**

IL ELAP / NELAC Accreditation # 100292

1600 Shore Road • Naperville, Illinois 60563 • Phone (630) 778-1200 • Fax (630) 778-1233

**Analytical Report**

**Client:** SEECO ENVIRONMENTAL SERVICES  
**Project ID:** 12182  
**Sample ID:** B-1 S-1  
**Sample No:** 19-3587-001

**Date Collected:** 06/08/19  
**Time Collected:**  
**Date Received:** 06/13/19  
**Date Reported:** 06/19/19

Results are reported on a dry weight basis.

Analyte	Result	R.L.	Units	Flags
<b>Semi-Volatile Compounds</b>				
Analysis Date: 06/14/19				
	<b>Method: 8270C</b>		<b>Preparation Method 3540C</b>	
			Preparation Date: 06/13/19	
Diethyl phthalate	< 330	330	ug/kg	
2,4-Dimethylphenol	< 330	330	ug/kg	
Dimethyl phthalate	< 330	330	ug/kg	
Di-n-butyl phthalate	< 330	330	ug/kg	
4,6-Dinitro-2-methylphenol	< 1,600	1600	ug/kg	
2,4-Dinitrophenol	< 1,600	1600	ug/kg	
2,4-Dinitrotoluene	< 250	250	ug/kg	
2,6-Dinitrotoluene	< 260	260	ug/kg	
Di-n-octylphthalate	< 330	330	ug/kg	
Fluoranthene	< 330	330	ug/kg	
Fluorene	< 330	330	ug/kg	
Hexachlorobenzene	< 330	330	ug/kg	
Hexachlorobutadiene	< 330	330	ug/kg	
Hexachlorocyclopentadiene	< 330	330	ug/kg	
Hexachloroethane	< 330	330	ug/kg	
Indeno(1,2,3-cd)pyrene	< 330	330	ug/kg	
Isophorone	< 330	330	ug/kg	
2-Methylnaphthalene	< 330	330	ug/kg	
2-Methylphenol	< 330	330	ug/kg	
3 & 4-Methylphenol	< 330	330	ug/kg	
Naphthalene	< 330	330	ug/kg	
2-Nitroaniline	< 1,600	1600	ug/kg	
3-Nitroaniline	< 1,600	1600	ug/kg	
4-Nitroaniline	< 1,600	1600	ug/kg	
Nitrobenzene	< 260	260	ug/kg	
2-Nitrophenol	< 1,600	1600	ug/kg	
4-Nitrophenol	< 1,600	1600	ug/kg	
n-Nitrosodi-n-propylamine	< 90	90	ug/kg	
n-Nitrosodimethylamine	< 330	330	ug/kg	
n-Nitrosodiphenylamine	< 330	330	ug/kg	
Pentachlorophenol	< 330	330	ug/kg	
Phenanthrene	< 330	330	ug/kg	
Phenol	< 330	330	ug/kg	
Pyrene	< 330	330	ug/kg	
Pyridine	< 330	330	ug/kg	
1,2,4-Trichlorobenzene	< 330	330	ug/kg	



**First  
Environmental  
Laboratories, Inc.**

IL ELAP / NELAC Accreditation # 100292

1600 Shore Road • Naperville, Illinois 60563 • Phone (630) 778-1200 • Fax (630) 778-1233

**Analytical Report**

**Client:** SEECO ENVIRONMENTAL SERVICES  
**Project ID:** 12182  
**Sample ID:** B-1 S-1  
**Sample No:** 19-3587-001

**Date Collected:** 06/08/19  
**Time Collected:**  
**Date Received:** 06/13/19  
**Date Reported:** 06/19/19

Results are reported on a dry weight basis.

Analyte	Result	R.L.	Units	Flags
<b>Semi-Volatile Compounds</b>				
<b>Method: 8270C</b>		<b>Preparation Method 3540C</b>		
Analysis Date: 06/14/19		Preparation Date: 06/13/19		
2,4,5-Trichlorophenol	< 330	330	ug/kg	
2,4,6-Trichlorophenol	< 330	330	ug/kg	
<b>Total Metals</b>				
<b>Method: 6010C</b>		<b>Preparation Method 3050B</b>		
Analysis Date: 06/17/19		Preparation Date: 06/14/19		
Arsenic	6.4	1.0	mg/kg	
Barium	100	0.5	mg/kg	
Cadmium	< 0.5	0.5	mg/kg	
Chromium	16.6	0.5	mg/kg	
Lead	13.8	0.5	mg/kg	
Selenium	< 1.0	1.0	mg/kg	
Silver	0.6	0.2	mg/kg	
<b>Total Mercury</b>				
<b>Method: 7471B</b>				
Analysis Date: 06/17/19				
Mercury	< 0.05	0.05	mg/kg	
<b>pH @ 25°C, 1:2</b>				
<b>Method: 9045D 2004</b>				
Analysis Date: 06/14/19 7:30				
pH @ 25°C, 1:2	8.32		Units	



First Environmental Laboratories, Inc.

CHAIN OF CUSTODY RECORD

First Environmental Laboratories

1600 Shore Road, Suite D
Naperville, Illinois 60563
Phone: (630) 778-1200 • Fax: (630) 778-1233
E-mail: firstinfo@firstenv.com • www.firstenv.com
IEPA Certification #100292

Company Name: SEELO
Street Address:
City: State: Zip:
Phone: e-mail: CASSIEN
Send Report To:
Sampled By:

Analyses

Table with columns: Date/Time Taken, Sample Description, Matrix, Comments, Lab I.D. Includes handwritten entries: 6/8/19, B-1 S-1, Soil, 19-3587-001. Diagonal text: PH, DTE & ACIA tabs, VOCs, SVOCs, Hold - Do Not Analyze.

FOR LAB USE ONLY:

Cooler Temperature: 0.1-6°C Yes \_\_\_ No \_\_\_ °C
Received within 6 hrs. of collection: \_\_\_
Ice Present: Yes \_\_\_ No \_\_\_
Sample Refrigerated: Yes \_\_\_ No \_\_\_
Refrigerator Temperature: \_\_\_ °C
5035 Vials Frozen: Yes \_\_\_ No \_\_\_
Freezer Temperature: \_\_\_ °C
Program: [ ] TACO/SRP [x] CGBB [ ] NPDES [ ] LUST [ ] SDWA

Notes and Special Instructions: EXTRA 10%

Relinquished By: [Signature] Date/Time 6/13/19
Received By: [Signature] Date/Time 6/13/19

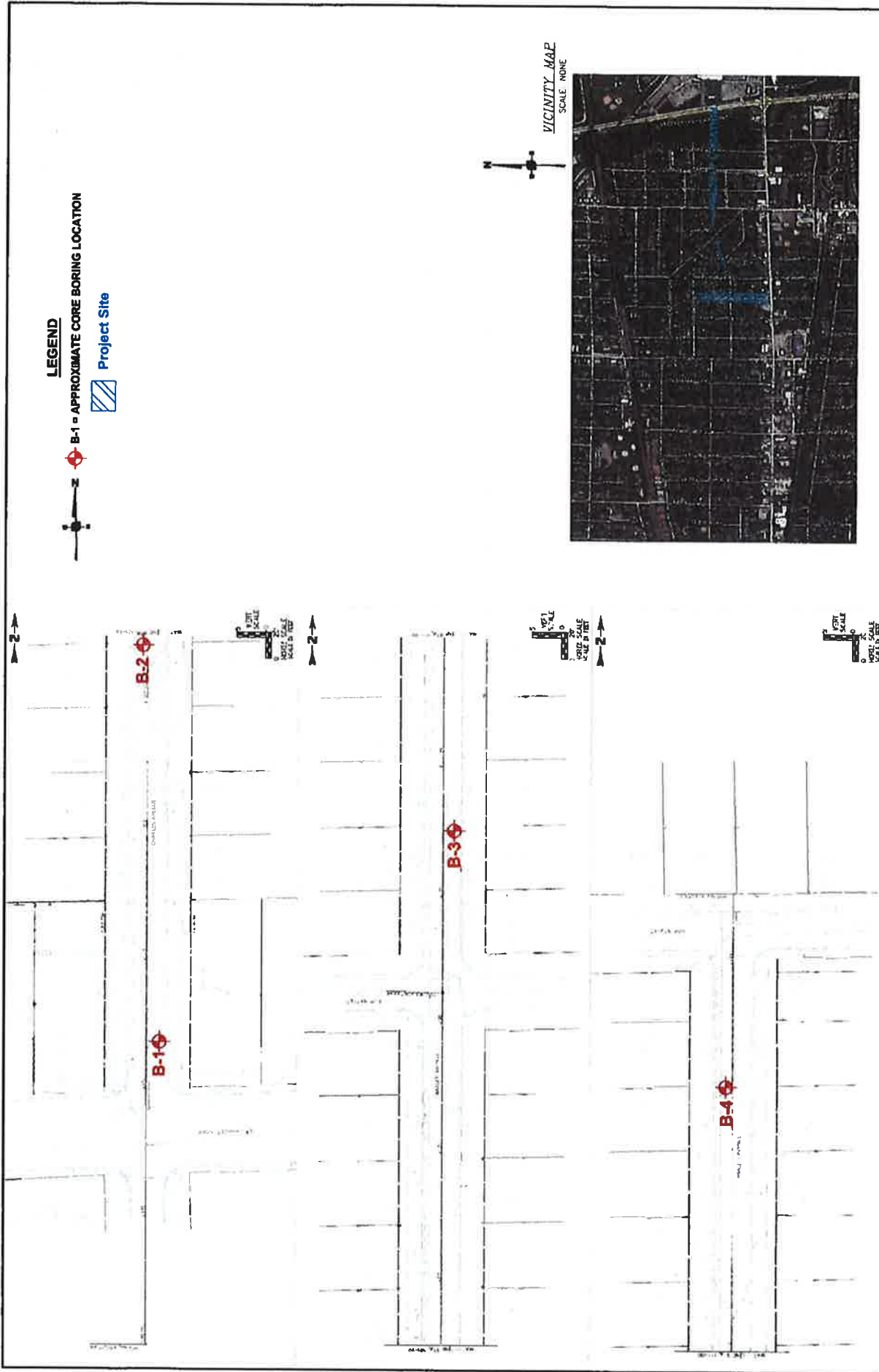

DATE	6/4/2019	SCALE	NONE	NO. OF SHEETS	1 OF 1
<b>CORE BORING LOCATION PLAN</b>					
PROJECT NAME & ADDRESS Chorus Avenue Reconstruction North Charles Avenue, Wino Park, IL 60181			CLIENT Stroud Associates, Inc.		
CONSULTANT <b>SEECO Consultants, Inc.</b> 1000 W. 15th Street, Suite 100 Chicago, IL 60604 OFFICE: (708) 433-1333 FAX: (708) 433-1333			DATE 6/4/2019		



**BORING LOG**

CLIENT <b>Strand and Associates, Inc.</b>	PROJECT <b>Charles Avenue Improvement Project</b>
ENGINEER <b>Strand and Associates, Inc.</b>	LOCATION <b>Charles Avenue, Villa Park, IL</b>

DEPTH ELEVATION	SAMPLE NO.	SAMPLER TYPE	SAMPLE REC. (%)	SOIL GRAPHIC LOG	BORING NUMBER <b>B-2</b>		Unconfined Compressive Strength, Tons/Ft. <sup>2</sup>					REMARKS	
					SURFACE ELEVATION (M.S.L.) <b>677.50</b>	STATION <b>105+40</b>	OFFSET from CL <b>8' LT</b>	1	2	3	4		5
					DESCRIPTION OF MATERIALS (LABORATORY CLASSIFICATION)								
					1.5" BITUMINOUS CONCRETE PAVEMENT								
					7.5" PORTLAND CEMENT CONCRETE BASE								
					FILL: CLAY, Brown and Gray, Some Dark Brown and Black, Trace Sand and Gravel, Medium, Moist (A-6)								
1	SS	0			No Recovery - Auger Sample		0						
2.5	HS				CLAY, Brown and Gray, Trace Sand and Gravel, Very Stiff to Hard, Moist (A-6)		0						
2	SS	72					0						
5.0	HS						0						
3	SS	89					0						
7.5	HS						0						
4	SS	50					0						
10.0	HS						0						
5	SS	78			CLAY, Gray, Trace Sand and Gravel, Very Stiff, Moist (A-6)		0						
12.5	HS						0						
6	SS	44					0						
15.0	HS						0						
7	SS	67					0						
17.5	HS						0						
8	SS	83					0						
20.0					End of Boring at 20 Feet.								
22.5					Note								
25.0					1) No Petroleum odors were observed in this boring utilizing olfactory senses. All the soil samples were screened with a MiniRae 3000 OVM photo-ionization device (PID) with all PID readings 0.0 ppm.								

☉ Calibrated Penetrometer Unconfined Compression

Water Level Observations		<b>SEECO</b> <b>Consultants, Inc.</b> 7350 Duwan Drive, Tinley Park, IL 60477	Boring Started <b>5/31/19</b>	
W.L.			Boring Completed <b>5/31/19</b>	
W.L.	<b>DRY WD/WS</b> <b>DRY ACR</b>		Driller <b>EN</b>	Rig <b>D-50</b>
W.L.			Approved <b>MB</b>	Job No. <b>12182G</b>
		Drawn By <b>NM</b>	Sheet <b>1 of 1</b>	

**BORING LOG**

CLIENT	<b>Strand and Associates, Inc.</b>	PROJECT	<b>Charles Avenue Improvement Project</b>
ENGINEER	<b>Strand and Associates, Inc.</b>	LOCATION	<b>Charles Avenue, Villa Park, IL</b>

DEPTH ELEVATION	SAMPLE NO.	SAMPLER TYPE	SAMPLE REC. (%)	SOIL GRAPHIC LOG	BORING NUMBER		Unconfined Compressive Strength, Tons/Ft. <sup>2</sup>					REMARKS
					<b>B-3</b>		1	2	3	4	5	
					SURFACE ELEVATION (M.S.L.)							
					STATION							
					OFFSET from CL							
					DESCRIPTION OF MATERIALS (LABORATORY CLASSIFICATION)							
					1.5" BITUMINOUS CONCRETE PAVEMENT							
					7.25" PORTLAND CEMENT CONCRETE BASE							
					9.25" FILL: CLAY, Dark Brown and Some Black, Trace Sand and Gravel, Medium, Moist							
1A	HS											
1B	SS	78										
2.5	HS											
2	SS	61										
5.0	HS											
3	SS	89										
7.5	HS											
4	SS	72										
10.0	HS											
5	SS	50										
12.5	HS											
6	SS	67										
15.0												
17.5												

Note:  
 1) No Petroleum odors were observed in this boring utilizing olfactory senses. All the soil samples were screened with a MiniRae 3000 OVM photo-ionization device (PID) with all PID readings 0.0 ppm.

☉ Calibrated Penetrometer Unconfined Compression

Water Level Observations			<p align="center"><b>SEECO</b>  <b>Consultants, Inc.</b>                  7350 Duvan Drive, Tinley Park, IL 60477</p>	Boring Started		5/31/19	
W.L.				Boring Completed		5/31/19	
W.L.	<b>DRY WD/WS</b>	<b>DRY ACR</b>		Approved	<b>MB</b>	Job No.	<b>12182G</b>

**BORING LOG**

CLIENT	<b>Strand and Associates, Inc.</b>	PROJECT	<b>Charles Avenue Improvement Project</b>
ENGINEER	<b>Strand and Associates, Inc.</b>	LOCATION	<b>Charles Avenue, Villa Park, IL</b>

DEPTH ELEVATION	SAMPLE NO.	SAMPLER TYPE	SAMPLE REC. (%)	SOIL GRAPHIC LOG	BORING NUMBER	Unconfined Compressive Strength, Tons/Ft. <sup>2</sup>					REMARKS
						1	2	3	4	5	
					<b>B-4</b>						
					SURFACE ELEVATION (M.S.L.)	<b>681.00</b>					
					STATION	<b>113+00</b>	OFFSET from CL	<b>8' LT</b>			
					DESCRIPTION OF MATERIALS (LABORATORY CLASSIFICATION)						
					1.5" BITUMINOUS CONCRETE PAVEMENT						
					6.5" PORTLAND CEMENT CONCRETE BASE						
	1A	SS	67		10" FILL: CLAY, Dark Brown, Some Black and Brown, Trace Sand and Gravel, Stiff, Moist						
2.5		HS			CLAY, Brown and Gray, Trace Sand and Gravel, Stiff to Very Stiff, Moist (A-6)						
	2	SS	83								
5.0		HS									
	3	SS	44								
7.5		HS									
	4	SS	61		CLAY, Gray, Trace Sand and Gravel, Very Stiff, Moist (A-6)						
10.0		HS									
	5	SS	56								
12.5		HS									
	6	SS	83								
15.0					End of Boring at 15 Feet.						
17.5					Note: 1) No Petroleum odors were observed in this boring utilizing olfactory senses. All the soil samples were screened with a MiniRae 3000 OVM photo-ionization device (PID) with all PID readings 0.0 ppm.						

⊗ Calibrated Penetrometer Unconfined Compression

Water Level Observations			<b>SEECO</b> <b>Consultants, Inc.</b> 7350 Duvan Drive, Tinley Park, IL 60477	Boring Started		<b>5/31/19</b>
W.L.				Boring Completed		<b>5/31/19</b>
W.L.	<b>DRY WD/WS</b>	<b>DRY ACR</b>		Driller	<b>EN</b>	Rig <b>D-50</b>
W.L.				Approved <b>MB</b>	Job No. <b>12182G</b>	Drawn By <b>NM</b> Sheet <b>1 of 1</b>

**APPENDIX G**  
**PERMITS**





1021 NORTH GRAND AVENUE EAST, P.O. BOX 19276, SPRINGFIELD, ILLINOIS 62794-9276 • (217) 782-3397

JB PRITZKER, GOVERNOR

JOHN J. KIM, DIRECTOR



(217) 782-1724

May 21, 2021

Richard Keehner, Jr., Village Manager  
Village of Villa Park  
20 South Ardmore Ave.  
Villa Park, IL 60181

Re: Villa Park (IL0430800)  
"Charles Avenue Improvements Project"  
Extension of Water Main Construction Permit No. 0802-FY2020

Dear Mr. Keehner:

In accordance with the request made through your engineers, Strand Associates, in a letter dated May 17, 2021, our Construction Permit No. 0802-FY2020, issued on May 1, 2020, for "Charles Avenue Improvements Project", is hereby extended.

This extension of the construction permit is void after May 20, 2022, unless construction on this project has started on or prior to that date.

Sincerely,

A handwritten signature in blue ink, appearing to read "D. Cook".

David C. Cook, P.E.  
Manager, Permit Section  
Division of Public Water Supplies

DCC:CE

cc: Strand Associates, Inc.  
Elgin Regional Office

**ILLINOIS ENVIRONMENTAL PROTECTION AGENCY**

1021 North Grand Avenue, East; Post Office Box 19276; Springfield, IL 62794-9276

Division of Public Water Supplies

Telephone 217/782-1724

**PUBLIC WATER SUPPLY CONSTRUCTION PERMIT**

SUBJECT: VILLA PARK (0430800)

Permit Issued to:  
Village of Villa Park  
20 S. Ardmore Ave.  
Villa Park, IL 60181

PERMIT NUMBER: 0802-FY2020

DATE ISSUED: May 1, 2020

PERMIT TYPE: Water Main Extension

The issuance of this permit is based on plans and specifications prepared by the engineers/architects indicated and are identified as follows. This permit is issued for the construction and/or installation of the public water supply improvements described in this document, in accordance with the provisions of the "Environmental Protection Act", Title IV, Sections 14 through 17, and Title X, Sections 39 and 40, and is subject to the conditions printed on the last page of this permit and the ADDITIONAL CONDITIONS listed below.

FIRM: Strand Associates, Inc.

NUMBER OF PLAN SHEETS: 18

TITLE OF PLANS: "Charles Avenue Improvements Project"

PROPOSED IMPROVEMENTS:

\*\*\* Installation of approximately 1,350 feet of water main with a nominal diameter of 8-inches.\*\*\*

ADDITIONAL CONDITIONS:

1. A lead informational notice must be given to each potentially affected residence at least 14 days prior to the permitted water main work. The notification must satisfy the requirements of Section 17.11 of the Environmental Protection Act. If notification is required to a residence that is a multi-dwelling building, posting at the primary entrance way to the building shall be sufficient. If the community water supply serves a population less than 3,301, alternative notification means may be utilized in lieu of an individual written notification. Refer to Section 17.11 of the Act for alternative notification requirements. Enclosed is suggested language for the notice. If this project involves water service to a significant proportion of non-English speaking consumers, the notification must contain information in the appropriate language regarding the importance and how to obtain a translated copy. The Responsible Operator in Charge of the community water system is responsible for preparing the notice. A copy of the notice used must be submitted to the Agency with the Application for Operating Permit.
2. All water mains shall be satisfactorily disinfected prior to use pursuant to Ill. Adm. Code, Title 35, Subtitle F, Section 602.310. Two consecutive sets of samples collected at least 24 hours apart must show the absence of coliform bacteria. The samples must be collected from every 1,200 feet of new water main along each branch and from the end of the line. An operating permit must be obtained before the project is placed in service.

VILLA PARK (0430800)  
PERMIT NUMBER: 0802-FY2020  
DATE ISSUED: May 1, 2020  
Page 2

3. There are no further conditions to this permit.

DCC:CLB

cc: Strand Associates, Inc.  
Elgin Regional Office  
IDPH/DEH – Plumbing and Water Quality Program  
DuPage County Department of Public Health



---

David C. Cook, P.E.  
Manager, Permit Section  
Division of Public Water Supplies

STANDARD CONDITIONS FOR CONSTRUCTION/DEVELOPMENT PERMITS  
ISSUED BY THE ILLINOIS ENVIRONMENTAL PROTECTION AGENCY

The Illinois Environmental Protection Agency Act (Illinois Compiled Statutes, Chapter 111-1/2, Section 1039) grants the Environmental Protection Agency authority to impose conditions on permits which it issues.

These standard conditions shall apply to all permits which the Agency issues for construction or development projects which require permits under the Division of Water Pollution Control, Air Pollution Control, Public Water Supplies and Land Pollution Control. Special conditions may also be imposed by the separate divisions in addition to these standard conditions.

1. Unless this permit has been extended or it has been voided by a newly issued permit, this permit will expire one year after this date of issuance unless construction or development on this project has started on or prior to that date. (See standard condition #8 below)
2. The construction or development of facilities covered by this permit shall be done in compliance with applicable provisions of Federal laws and regulations, the Illinois Environmental Protection Act, and Rules and Regulations adopted by the Illinois Pollution Control Board.
3. There shall be no deviations from the approved plans and specifications unless a written request for modification of the project, along with plans and specifications as required, shall have been submitted to the Agency and a supplemental written permit issued.
4. The permittee shall allow any agent duly authorized by the Agency upon the presentation of credentials:
  - a. to enter at reasonable times the permittee's premises where actual or potential effluent, emission or noise sources are located or where any activity is to be conducted pursuant to this permit.
  - b. to have access to and copy at reasonable times any records required to be kept under the terms and conditions of this permit.
  - c. to inspect at reasonable times, including during any hours of operation of equipment constructed or operated under this permit, such equipment or monitoring methodology or equipment required to be kept, used, operated, calibrated and maintained under this permit.
  - d. to obtain and remove at reasonable times samples of any discharge or emission of pollutants.
  - e. to enter at reasonable times and utilize any photographic, recording, testing, monitoring or other equipment for the purpose of preserving, testing, monitoring, or recording any activity, discharge, or emission authorized by this permit.
5. The issuance of this permit:
  - a. shall not be considered as in any manner affecting the title of the permits upon which the permitted facilities are to be located;
  - b. does not release the permittee from any liability for damage to person or property caused by or resulting from the construction, maintenance, or operation of the proposed facilities;
  - c. does not release the permittee from compliance with the other applicable statutes and regulations of the United States, of the State of Illinois, or with applicable local laws, ordinances and regulations;
  - d. does not take into consideration or attest to the structural stability of any units or parts of the project;
  - e. in no manner implies or suggests that the Agency (or its officers, agents or employees) assumes any liability directly or indirectly for any loss due to damage, installation, maintenance, or operation of the proposed equipment or facility.
6. These standard conditions shall prevail unless modified by special conditions.
7. The Agency may file a complaint with Board of modification, suspension or revocation of a permit:
  - a. upon discovery that the permit application misrepresentation or false statements or that all relevant facts were not disclosed; or
  - b. upon finding that any standard or special conditions have been violated; or
  - c. upon any violation of the Environmental Protection Act or any Rules or Regulation effective thereunder as a result of the construction or development authorized by this permit.
8. Division of Public Water Supply Construction Permits expire one year from date of issuance or renewal, unless construction has started. If construction commences within one year from date of issuance or renewal, the permit expires five years from the date of permit issuance or renewal. A request for extension shall be filed prior to the permit expiration date.