

OWNER COPY



**Illinois Department
of Transportation**

CONTRACT

**Local Public Agency
Formal Contract**

PROPOSAL SUBMITTED BY		
United Enterprise, LLC		
Contractor's Name		
9220 Ogden Ave, Ste. R		
Street		P.O. Box
Brookfield	IL	60513
City	State	Zip Code

STATE OF ILLINOIS
 COUNTY DuPage
Village of Villa Park
 (Name of City, Village, Town or Road District)

FOR THE IMPROVEMENT OF
 STREET NAME OR ROUTE South Michigan Avenue
 SECTION NO. N/A
 TYPES OF FUNDS Local

SPECIFICATIONS (required)

PLANS (required)

CONTRACT BOND (when required)

For Municipal Projects
 Submitted/Approved/Passed

Mayor President of Board of Trustees Municipal Official

Date

Department of Transportation
 Concurrence in approval of award

Regional Engineer

Date

For County and Road District Projects
 Submitted/Approved

Highway Commissioner

Date

Submitted/Approved

County Engineer/Superintendent of Highways

Date

County DuPage
Local Public Agency Village of Villa Park
Section Number N/A
Route South Michigan Avenue

1. THIS AGREEMENT, made and concluded the 6th day of July, 2020,
Month and Year

between the Village of Villa Park
acting by and through its Board of Trustees known as the party of the first part, and
United Enterprise, LLC his/their executors, administrators, successors or assigns,
known as the party of the second part.

2. Witnesseth: That for and in consideration of the payments and agreements mentioned in the Proposal hereto attached, to be made and performed by the party of the first part, and according to the terms expressed in the Bond referring to these presents, the party of the second part agrees with said party of the first part at his/their own proper cost and expense to do all the work, furnish all materials and all labor necessary to complete the work in accordance with the plans and specifications hereinafter described, and in full compliance with all of the terms of this agreement and the requirements of the Engineer under it.

3. And it is also understood and agreed that the LPA Formal Contract Proposal, Special Provisions, Affidavit of Illinois Business Office, Apprenticeship or Training Program Certification, and Contract Bond hereto attached, and the Plans for Section South Michigan Avenue, in The Village of Villa Park, approved by the Illinois Department of Transportation on N/A, Date, are essential documents of this contract and are a part hereof.

4. IN WITNESS WHEREOF, The said parties have executed these presents on the date above mentioned.

Attest: [Signature] The Village of Villa Park
Village Clerk By Albert Butthous
Party of the First Part

(Seal)



(If a Corporation)

Corporate Name United Enterprise, LLC

By [Signature] President Party of the Second Part

(If a Co-Partnership)

Attest: [Signature]
Secretary

Partners doing Business under the firm name of

Party of the Second Part

(If an individual)

Party of the Second Part

OWNER COPY

CONTRACT



OWNER COPY

CONTRACT

IN TESTIMONY WHEREOF, the said PRINCIPAL and the said SURETY have caused this instrument to be signed by their respective officers this 26th day of June A.D. 2020

PRINCIPAL

United Enterprise, LLC (Company Name)

By: [Signature] (Signature & Title)

Attest: [Signature] Secretary (Signature & Title)

(Company Name)

By: (Signature & Title)

Attest: (Signature & Title)

(If PRINCIPAL is a joint venture of two or more contractors, the company names and authorized signature of each contractor must be affixed.)

STATE OF ILLINOIS,

COUNTY OF Cook

I, Raymundo Ramirez, a Notary Public in and for said county, do hereby certify that

(Insert names of individuals signing on behalf or PRINCIPAL)

who are each personally known to me to be the same persons whose names are subscribed to the foregoing instrument on behalf of PRINCIPAL, appeared before me this day in person and acknowledged respectively, that they signed and delivered said instrument as their free and voluntary act for the uses and purposes therein set forth.

Given under my hand and notarial seal this 26th day of June

My commission expires 05/31/2022

[Signature]

Notary Public

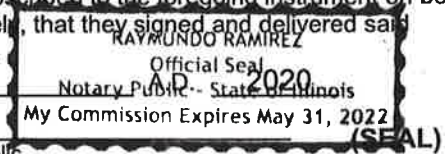

SURETY

Old Republic Surety Company (Name of Surety)

By: [Signature] (Signature of Attorney-in-Fact) James I. Moore (SEAL)

STATE OF ILLINOIS.

COUNTY OF DuPage

I, Sherry Bacskai, a Notary Public in and for said county, do hereby certify that

James I. Moore

(Insert names of individuals signing on behalf or SURETY)

who are each personally known to me to be the same persons whose names are subscribed to the foregoing instrument on behalf of SURETY, appeared before me this day in person and acknowledged respectively, that they signed and delivered said instrument as their free and voluntary act for the uses and purposes therein set forth.

Given under my hand and notarial seal this 26th day of June

My commission expires 10/22/2023

[Signature]

Notary Public

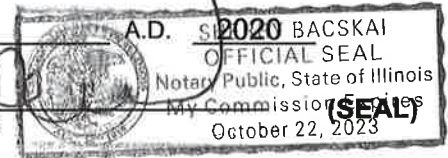

Approved this 6th day of July, A.D. 2020

Attest: [Signature] Village Clerk

Village of Villa Park (Awarding Authority) [Signature] (Chairman/Mayor/President)





OLD REPUBLIC SURETY COMPANY

POWER OF ATTORNEY

KNOW ALL MEN BY THESE PRESENTS: That OLD REPUBLIC SURETY COMPANY, a Wisconsin stock insurance corporation, does make, constitute and appoint:

James I. Moore

Its true and lawful Attorney(s)-in-Fact, with full power and authority, not exceeding \$50,000,000, for and on behalf of the company as surety, to execute and deliver and affix the seal of the company thereto (if a seal is required), bonds, undertakings, recognizances or other written obligations in the nature thereof, (other than bail bonds, bank depository bonds, mortgage deficiency bonds, mortgage guaranty bonds, guarantees of installment paper and note guaranty bonds, self-insurance workers compensation bonds guaranteeing payment of benefits, asbestos abatement contract bonds, waste management bonds, hazardous waste remediation bonds or black lung bonds), as follows: Execution Date: June 26, 2020

Surety Bond number: 5926437
Principal: United Enterprise, LLC
Obligee: Village of Villa Park

and to bind OLD REPUBLIC SURETY COMPANY thereby, and all of the acts of said Attorneys-in-Fact, pursuant to these presents, are ratified and confirmed. This appointment is made under and by authority of the board of directors at a special meeting held on February 18, 1982.

This Power of Attorney is signed and sealed by facsimile under and by the authority of the following resolutions adopted by the board of directors of the OLD REPUBLIC SURETY COMPANY on February 18, 1982.

RESOLVED that, the president, any vice-president or assistant vice president, in conjunction with the secretary or any assistant secretary, may appoint attorneys-in-fact or agents with authority as defined or limited in the instrument evidencing the appointment in each case, for and on behalf of the company to execute and deliver and affix the seal of the company to bonds, undertakings, recognizances, and suretyship obligations of all kinds; and said officers may remove any such attorney-in-fact or agent and revoke any Power of Attorney previously granted to such person.

RESOLVED FURTHER, that any bond, undertaking, recognizance, or suretyship obligation shall be valid and binding upon the Company

- (i) when signed by the president, any vice president or assistant vice president, and attested and sealed (if a seal be required) by any secretary or assistant secretary; or
- (ii) when signed by the president, any vice president or assistant vice president, secretary or assistant secretary, and countersigned and sealed (if a seal be required) by a duly authorized attorney-in-fact or agent; or
- (iii) when duly executed and sealed (if a seal be required) by one or more attorneys-in-fact or agents pursuant to and within the limits of the authority evidenced by the Power of Attorney issued by the company to such person or persons.

RESOLVED FURTHER that the signature of any authorized officer and the seal of the company may be affixed by facsimile to any Power of Attorney or certification thereof authorizing the execution and delivery of any bond, undertaking, recognizance, or other suretyship obligations of the company; and such signature and seal when so used shall have the same force and effect as though manually affixed.

IN WITNESS WHEREOF, OLD REPUBLIC SURETY COMPANY has caused these presents to be signed by its proper officer, and its corporate seal to be affixed this 1st day of October, 2018.

OLD REPUBLIC SURETY COMPANY

Assistant Secretary



President

STATE OF WISCONSIN, COUNTY OF WAUKESHA - SS

On this 1st day of October, 2018, personally came before me, Alan Pavlic and Jane E. Cherney, to me known to be the Individuals and officers of the OLD REPUBLIC SURETY COMPANY who executed the above instrument, and they each acknowledged the execution of the same, and being by me duly sworn, did severally depose and say: that they are the said officers of the corporation aforesaid, and that the seal affixed to the above instrument is the seal of the corporation, and that said corporate seal and their signatures as such officers were duly affixed and subscribed to the said instrument by the authority of the board of directors of said corporation.



Notary Public

My Commission Expires: September 28, 2022

(Expiration of notary's commission does not invalidate this instrument)

CERTIFICATE

I, the undersigned, assistant secretary of the OLD REPUBLIC SURETY COMPANY, a Wisconsin corporation, CERTIFY that the foregoing and attached Power of Attorney remains in full force and has not been revoked; and furthermore, that the Resolutions of the board of directors set forth in the Power of Attorney, are now in force.

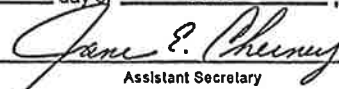

Signed and sealed at the City of Brookfield, WI this 26th day of June, 2020.

Assistant Secretary

Policy #AB9241199

**CG 20 10 10 01
ADDITIONAL INSURED - OWNERS, LESSEES OR CONTRACTORS -
SCHEDULED PERSON OR ORGANIZATION**

This endorsement modifies insurance provided under the following:

COMMERCIAL GENERAL LIABILITY COVERAGE PART

SCHEDULE

Name of Person or Organization: As listed on the certificate of insurance

(If no entry appears above, information required to complete this endorsement will be shown in the Declarations as applicable to this endorsement.)

A. Section II - Who Is An Insured is amended to include as an insured the person or organization shown in the Schedule, but only with respect to liability arising out of your ongoing operations performed for that insured.

B. With respect to the insurance afforded to these additional insureds, the following exclusion is added:

2. Exclusions

This insurance does not apply to "bodily injury" or "property damage" occurring after:

(1) All work, including materials, parts or equipment furnished in connection with such work, on the project (other than service, maintenance or repairs) to be performed by or on behalf of the additional insured(s) at the site of the covered operations has been completed; or

(2) That portion of "your work" out of which the injury or damage arises has been put to its intended use by any person or organization other than another contractor or subcontractor engaged in performing operations for a principal as a part of the same project.

CG 20 10 10 01

© ISO Properties, Inc., 2000

Policy #AB9241199

**CG 20 37 10 01
ADDITIONAL INSURED - OWNERS, LESSEES OR CONTRACTORS -
COMPLETED OPERATIONS**

This endorsement modifies insurance provided under the following:

COMMERCIAL GENERAL LIABILITY COVERAGE PART

SCHEDULE

Name of Person or Organization: As listed on the certificate of insurance

Location And Description of Completed Operations:

(If no entry appears above, information required to complete this endorsement will be shown in the Declarations as applicable to this endorsement.)

Section II - Who Is An Insured is amended to include as an insured the person or organization shown in the Schedule, but only with respect to liability arising out of "your work" at the location designated and described in the schedule of this endorsement performed for that insured and included in the "products-completed operations hazard".

CG 20 37 10 01

© ISO Properties, Inc., 2000

THIS ENDORSEMENT CHANGES THE POLICY. PLEASE READ IT CAREFULLY.

DESIGNATED INSURED FOR COVERED AUTOS LIABILITY COVERAGE

This endorsement modifies insurance provided under the following:

AUTO DEALERS COVERAGE FORM
BUSINESS AUTO COVERAGE FORM
MOTOR CARRIER COVERAGE FORM

With respect to coverage provided by this endorsement, the provisions of the Coverage Form apply unless modified by this endorsement.

This endorsement identifies person(s) or organization(s) who are "insureds" for Covered Autos Liability Coverage under the Who Is An Insured provision of the Coverage Form. This endorsement does not alter coverage provided in the Coverage Form.

This endorsement changes the policy effective on the inception date of the policy unless another date is indicated below.

Named Insured: UNITED ENTERPRISE LLC

Endorsement Effective Date: 6/30/2020

SCHEDULE

Name Of Person(s) Or Organization(s):

(See following Schedule)

Information required to complete this Schedule, if not shown above, will be shown in the Declarations.

Each person or organization shown in the Schedule is an "insured" for Covered Autos Liability Coverage, but only to the extent that person or organization qualifies as an "insured" under the Who Is An Insured provision contained in Paragraph **A.1.** of Section **II** – Covered Autos Liability Coverage in the Business Auto and Motor Carrier Coverage Forms and Paragraph **D.2.** of Section **I** – Covered Autos Coverages of the Auto Dealers Coverage Form.

Schedule for Endorsement

CA2048 FOR POLICY AB9241199

VILLAGE OF VILLA PARK, ITS OFFICIALS, EMPLOYEES, AGENTS AND VOLUNTEERS

STRAND ASSOCIATES, INC.

RETURN WITH BID



SCHEDULE OF PRICES

A bid will be declared unacceptable if neither a unit price nor total price is shown.

County DuPage
 Local Public Agency Village of Villa Park
 Section N/A
 Route South Michigan Avenue

Schedule for Multiple Bids

Combination Letter	Sections Included in Combinations	Total

Schedule for Single Bid

(For complete information covering these items, see plans and specifications)

Bidder's Proposal for making Entire Improvements

Item No.	Items	Unit	Quantity	Unit Price	Total
1	TREE REMOVAL (OVER 15 UNITS DIAMETER)	UNIT	87	46	4002. ⁰⁰
2	STUMP REMOVAL	UNIT	27	115. ²⁰	3,110. ⁴⁰
3	TREE PROTECTION FENCING	EACH	53	97	5,141. ⁰⁰
4	TREE ROOT PRUNING	EACH	53	128	6,784. ⁰⁰
5	TREE PRUNING (1 TO 10 INCH DIAMETER)	EACH	8	144. ⁵⁰	1,156. ⁰⁰
6	TREE PRUNING (OVER 10 INCH DIAMETER)	EACH	45	260	11,700. ⁰⁰
7	TREES	EACH	12	481	5,772. ⁰⁰
8	EARTH EXCAVATION	CU YD	1,950	45	87,750. ⁰⁰
9	REMOVAL AND DISPOSAL OF UNSUITABLE MATERIAL	CU YD	812	50	40,600. ⁰⁰
10	TRENCH BACKFILL	CU YD	426	37	15,762. ⁰⁰
11	GEOTECHNICAL FABRIC FOR GROUND STABILIZATION	SQ YD	4,868	1	4,868. ⁰⁰
12	PARKWAY RESTORATION	SQ YD	2,300	16	36,800. ⁰⁰
13	PERIMETER EROSION BARRIER	FOOT	250	3	750. ⁰⁰
14	INLET FILTERS	EACH	26	100	2,600. ⁰⁰
15	AGGREGATE SUBGRADE IMPROVEMENT	CU YD	812	42	34,104. ⁰⁰
16	AGGREGATE BASE COURSE, TYPE B 6"	SQ YD	4,868	7	34,076. ⁰⁰
17	BITUMINOUS MATERIALS (TACK COAT)	POUND	4,390	0. ⁵⁰	2,195. ⁰⁰
18	HOT-MIX ASPHALT BINDER COURSE, IL-19.0, N50	TON	1,134	77	87,318. ⁰⁰

RETURN WITH BID

Bidder's Proposal for making Entire Improvements

Item No.	Items	Unit	Quantity	Unit Price	Total
19	HOT-MIX ASPHALT SURFACE COURSE, MIX "D", N50	TON	574	91. ⁵⁰	52,521. ⁰⁰
20	PROTECTIVE COAT	SQ YD	2,006	1	2,006. ⁰⁰
21	HOT-MIX ASPHALT DRIVEWAY PAVEMENT, 4"	SQ YD	680	62	42,160. ⁰⁰
22	PORTLAND CEMENT CONCRETE DRIVEWAY PAVEMENT, 6 INCH	SQ YD	500	49	24,500. ⁰⁰
23	PORTLAND CEMENT CONCRETE SIDEWALK 5 INCH	SQ FT	3,590	6	21,540. ⁰⁰
24	DETECTABLE WARNINGS	SQ FT	140	35	4,900. ⁰⁰
25	PAVEMENT REMOVAL	SQ YD	4,868	21	102,228. ⁰⁰
26	DRIVEWAY PAVEMENT REMOVAL	SQ YD	1,051	14	14,714. ⁰⁰
27	COMBINATION CURB AND GUTTER REMOVAL	FOOT	3,870	6	23,220. ⁰⁰
28	SIDEWALK REMOVAL	SQ FT	4,020	1. ⁵⁰	6,030. ⁰⁰
29	STORM SEWERS, RUBBER GASKET, CLASS A, TYPE 1 12"	FOOT	39	57	2,223. ⁰⁰
30	STORM SEWERS, RUBBER GASKET, CLASS A, TYPE 2 12"	FOOT	143	45	6,435. ⁰⁰
31	STORM SEWERS, RUBBER GASKET, CLASS A, TYPE 1 24"	FOOT	155	95	14,725. ⁰⁰
32	STORM SEWERS, RUBBER GASKET, CLASS A, TYPE 2 24"	FOOT	401	97	38,897. ⁰⁰
33	STORM SEWER RESTRICTOR 15"	EACH	1	300	300. ⁰⁰
34	STORM SEWER (WATER MAIN REQUIREMENTS) 12 INCH	FOOT	121	85	10,285. ⁰⁰
35	STORM SEWER REMOVAL 8"	FOOT	66	10	660. ⁰⁰
36	PVC PIPE DRAINS SDR 26 ASTM D-2241, 6"	FOOT	150	77	11,550. ⁰⁰
37	CATCH BASINS, TYPE A, 4'-DIAMETER	EACH	2	3,500	7,000. ⁰⁰
38	CATCH BASINS, TYPE C	EACH	12	2,100	25,200. ⁰⁰
39	MANHOLES, TYPE A, 5'-DIAMETER	EACH	6	4,700	28,200. ⁰⁰
40	INLETS, TYPE A	EACH	2	1,000	2,000. ⁰⁰
41	FRAMES AND GRATES, TYPE 11	EACH	2	450	900. ⁰⁰
42	FRAMES AND GRATES, TYPE 11V	EACH	14	450	6,300. ⁰⁰
43	FRAMES AND LIDS, TYPE 1, CLOSED LID	EACH	11	325	3,575. ⁰⁰
44	MANHOLES TO BE ADJUSTED	EACH	5	400	2,000. ⁰⁰
45	INLETS TO BE ADJUSTED	EACH	7	350	2,450. ⁰⁰
46	VALVE VAULTS TO BE ADJUSTED	EACH	2	400	800. ⁰⁰
47	REMOVING MANHOLES	EACH	7	400	2,800. ⁰⁰
48	REMOVING CATCH BASINS	EACH	3	400	1,200. ⁰⁰
49	REMOVING INLETS	EACH	3	50	150. ⁰⁰

RETURN WITH BID

Bidder's Proposal for making Entire Improvements

Item No.	Items	Unit	Quantity	Unit Price	Total
50	REMOVE WATER VALVE	EACH	4	1,000	4,000. ⁰⁰
51	WATER VALVES 6"	EACH	4	5,000	20,000. ⁰⁰
52	VALVE VAULTS, TYPE A, 4'-DIAMETER	EACH	1	2,500	2,500. ⁰⁰
53	FIRE HYDRANTS TO BE REMOVED	EACH	5	2,000	10,000. ⁰⁰
54	FIRE HYDRANT WITH AUXILIARY VALVE AND VALVE BOX	EACH	8	5,000	40,000. ⁰⁰
55	WATER SERVICE CONNECTION (LONG) 1"	EACH	31	1,450	44,950. ⁰⁰
56	WATER SERVICE CONNECTION (SHORT) 1"	EACH	29	1,100	31,900. ⁰⁰
57	DOMESTIC WATER SERVICE BOXES TO BE MOVED	EACH	2	750	1,500. ⁰⁰
58	ADJUSTING WATER SERVICE LINES	EACH	23	777	17,871. ⁰⁰
59	WATER MAIN RELOCATION CONNECTION TO EXISTING WATER MAIN, 6"	EACH	6	4,300	25,800. ⁰⁰
60	SANITARY SEWER SERVICE REPLACEMENT	FOOT	252	35	8,820. ⁰⁰
62	SANITARY SEWER SERVICE RECONNECTION	EACH	14	700	9,800. ⁰⁰
63	SANITARY SEWER PIPE, PVC SDR 26 ASTM D-2241, 15"	FOOT	37	37	1,369. ⁰⁰
64	SANITARY MANHOLES, TYPE A, 4'-DIAMETER	EACH	4	5,700	22,800. ⁰⁰
65	SANITARY SEWER SERVICE COMBINATION CLEAN OUT CHECK VALVE	EACH	14	500	7,000. ⁰⁰
66	ADJUSTING SANITARY SEWER SERVICE LINE	EACH	9	300	2,700. ⁰⁰
67	NON-SPECIAL WASTE DISPOSAL	CU YD	100	150	15,000. ⁰⁰
68	TRAFFIC CONTROL AND PROTECTION (SPECIAL)	LSUM	1	27,000	27,000. ⁰⁰
69	THERMOPLASTIC PAVEMENT MARKING - LINE 12"	FOOT	168	3	504. ⁰⁰
70	THERMOPLASTIC PAVEMENT MARKING - LINE 24"	FOOT	44	32	1,408. ⁰⁰
71	DUST CONTROL WATERING	UNIT	30	200	6,000. ⁰⁰
72	WATER SERVICE INVESTIGATION	EACH	60	200	12,000. ⁰⁰
73	SANITARY SERVICE INVESTIGATION	EACH	23	200	4,600. ⁰⁰
74	EXPLORATION TRENCH, SPECIAL	FOOT	500	25	12,500. ⁰⁰
75	AGGREGATE TEMPORARY ACCESS (PRIVATE ENTRANCE)	EACH	52	50	2,600. ⁰⁰

RETURN WITH BID

Bidder's Proposal for making Entire Improvements

Item No.	Items	Unit	Quantity	Unit Price	Total
76	HOT-MIX ASPHALT TEMPORARY ACCESS (ROAD)	EACH	4	500	2,000. ⁰⁰
77	SANITARY MANHOLES TO BE ADJUSTED	EACH	3	600	1,800. ⁰⁰
78	COMBINATION CONCRETE CURB AND GUTTER, TYPE B- 6.12 (SPECIAL)	FOOT	3,860	20	77,200. ⁰⁰
79	INCIDENTAL HOT-MIX ASPHALT SURFACING	TON	1	50. ⁵⁰	50. ⁵⁰
80	CONSTRUCTION LAYOUT	LSUM	1	10,000	10,000. ⁰⁰
81	PRE-CONSTRUCTION VIDEO RECORDING	LSUM	1	10,000	10,000. ⁰⁰
82	POST-CONSTRUCTION SEWER TELEVISIONING	LSUM	1	10,000	10,000. ⁰⁰
83	WATER USAGE DEDUCTION	TGAL	100	-\$8.85	-\$885.00
84	WATER USAGE CREDIT	TGAL	100	\$8.85	\$885.00
85	CONTINGENCY ALLOWANCE	DOLLAR	30,000	\$1.00	\$30,000.00

Total \$ 1,328,629.⁹⁰



VILLAGE OF VILLA PARK

CONTRACT DOCUMENTS

FOR

***MICHIGAN AVENUE IMPROVEMENT PROJECT
(CENTRAL TO KENILWORTH)***

MARCH 2020

PREPARED BY

BAXTER & WOODMAN, INC.

**ADVERTISEMENT FOR BIDS
VILLAGE OF VILLA PARK
FRIDAY, APRIL 3, 2020**

PROJECT: MICHIGAN AVENUE IMPROVEMENT PROJECT (CENTRAL TO KENILWORTH)

This project consists of the reconstruction of South Michigan Avenue from West Central Boulevard to West Kenilworth Avenue in the Village of Villa Park for a length of 1,880 feet. The scope of work includes roadway reconstruction; storm sewer installation; sanitary sewer repairs; water main service adjustment; sidewalk repair; parkway restoration; and other miscellaneous items of work.

BID DEADLINE: FRIDAY, MAY 1, 2020, 10:00 A.M. LOCAL TIME

The Village reserves the right to extend the Bid Deadline from this date and time to accept Bids submitted after the Bid Deadline, as the Village, in its sole discretion, determines is in the best interest of the Village.

NOTICE: Separate, sealed proposals for the **MICHIGAN AVENUE IMPROVEMENT PROJECT (CENTRAL TO KENILWORTH)** project will be received through QuestCDN, until the Bid Deadline. Immediately thereafter, the proposals will be publicly opened and read aloud via conference call (800-503-2899 Access Code: 8909732). Notwithstanding the foregoing, the Village reserves the right to defer, postpone, delay, or reschedule the Bid Opening for such time and to such date as the Village, in its sole discretion, determines is in the best interest of the Village.

Proposals shall be submitted in accordance with the Bidding Documents prepared by Baxter & Woodman, Inc., 8678 Ridgefield Road, Crystal Lake, Illinois 60012.

BIDDER QUALIFICATIONS: Bidders, in submitting a Bid, shall comply with all applicable Federal, State and Local laws and requirements; shall provide documentation of that compliance in accordance with the requirements of the Contract Documents or as requested by the Village; and, in submitting a Bid, Bidders affirm that they are qualified under all applicable laws and requirements to do so, and agree to be bound by the determination of the Village as to Bidder's compliance and qualifications.

BID SECURITY: Bid security in the amount of not less than five percent (5%) of the Bid shall accompany each Bid in accordance with the Bidding Documents.

CONTRACT SECURITY: The Bidder to whom a Contract is awarded shall be required to furnish both a Performance Bond acceptable to the Village for one-hundred percent (100%) of the Contract Price, in accordance with the requirements of the Contract Documents.

RIGHTS RESERVED: The Village will select the lowest, most responsible bidder. The Village reserves the right to reject any and all Bids, to waive any informalities or

technicalities in bidding, and to accept the Bid which best serves the interests of the Village. The Village shall, in its sole discretion, determine what does or does not constitute an informality or technicality, and, in submitting a Bid, Bidder agrees to be bound by that determination.

The Village may make such investigations as it deems necessary to determine the ability of the Bidder to perform the Work, and the Bidder shall furnish to the Village all such information and data for this purpose as the Village may request. The Village reserves the right to reject any Bid if the evidence submitted by, or investigation of, such Bidder fails to satisfy the Village that such Bidder is properly qualified to carry out the obligations of the Agreement and to complete the Work contemplated therein.

WAGE RATES: All applicable laws, ordinances, and the rules and regulations of all authorities having jurisdiction over construction of the PROJECT shall apply to the contract throughout.

CONTRACT DOCUMENTS: The Bidding Documents will only be available from QuestCDN e-delivery. No paper copies will be available.

PUBLISHED BY AUTHORITY OF THE VILLAGE OF VILLA PARK, DUPAGE COUNTY, ILLINOIS.

OWNER COPY

CONTRACT



Local Public Agency
Formal Contract Proposal

PROPOSAL SUBMITTED BY		
United Enterprise, LLC		
Contractor's Name		
9220 Ogden Ave. Ste. R.		
Street	P.O. Box	
Brookfield	IL	60513
City	State	Zip Code

STATE OF ILLINOIS
 COUNTY OF DuPage
Village of Villa Park
 (Name of City, Village, Town or Road District)

FOR THE IMPROVEMENT OF
 STREET NAME OR ROUTE NO. South Michigan Avenue
 SECTION NO. N/A
 TYPES OF FUNDS Local

SPECIFICATIONS (required)

PLANS (required)

For Municipal Projects
 Submitted/Approved/Passed

Mayor President of Board of Trustees Municipal Official

Date

Department of Transportation

Released for bid based on limited review

Regional Engineer

Date

For County and Road District Projects
 Submitted/Approved

Highway Commissioner

Date

Submitted/Approved

County Engineer/Superintendent of Highways

Date

Note: All proposal documents, including Proposal Guaranty Checks or Proposal Bid Bonds, should be stapled together to prevent loss when bids are processed.

RETURN WITH BID

NOTICE TO BIDDERS

Addendum 2 - 4/29/2020

County DuPage
 Local Public Agency Village of Villa Park
 Section Number N/A
 Route South Michigan Avenue

Sealed proposals for the improvement described below will be received ~~at the office of~~ Via QuestCDN,
Paper copies will not be accepted until 10:00 AM on May 15, 2020
 Time Date

Sealed proposals will be opened and read publicly ~~at the office of~~ Via conference line,
800-503-2899 Access Code: 8909732 at 10:00 AM on May 15, 2020
 Time Date

DESCRIPTION OF WORK

Name Michigan Avenue Improvement Project Length: 1,882 feet (0.356 miles)
 Location South Michigan Avenue from West Central Boulevard to West Kenilworth Avenue, Villa Park, DuPage County
 Proposed Improvement Roadway reconstruction; storm sewer installation; sanitary sewer repairs;
water main service adjustment; sidewalk repair; parkway restoration; and other miscellaneous items of work.

1. Plans and proposal forms will be available: For purchase and download via QuestCDN e-delivery
For information on bidding proposals contact Villa Park at 630.834.8505
2. Prequalification
 If checked, the 2 low bidders must file within 24 hours after the letting an "Affidavit of Availability" (Form BC 57), in duplicate, showing all uncompleted contracts awarded to them and all low bids pending award for Federal, State, County, Municipal and private work. One original shall be filed with the Awarding Authority and one original with the IDOT District Office.
3. The Awarding Authority reserves the right to waive technicalities and to reject any or all proposals as provided in BLRS Special Provision for Bidding Requirements and Conditions for Contract Proposals.
4. The following BLR Forms shall be returned by the bidder to the Awarding Authority:
 - a. BLR 12200: Local Public Agency Formal Contract Proposal
 - b. BLR 12200a Schedule of Prices
 - c. BLR 12230: Proposal Bid Bond (if applicable)
 - d. BLR 12325: Apprenticeship or Training Program Certification (do not use for federally funded projects)
 - e. BLR 12326: Affidavit of Illinois Business Office

RETURN WITH BID

5. The quantities appearing in the bid schedule are approximate and are prepared for the comparison of bids. Payment to the Contractor will be made only for the actual quantities of work performed and accepted or materials furnished according to the contract. The scheduled quantities of work to be done and materials to be furnished may be increased, decreased or omitted as hereinafter provided.
6. Submission of a bid shall be conclusive assurance and warranty the bidder has examined the plans and understands all requirements for the performance of work. The bidder will be responsible for all errors in the proposal resulting from failure or neglect to conduct an in depth examination. The Awarding Authority will, in no case be responsible for any costs, expenses, losses or changes in anticipated profits resulting from such failure or neglect of the bidder.
7. The bidder shall take no advantage of any error or omission in the proposal and advertised contract.
8. If a special envelope is supplied by the Awarding Authority, each proposal should be submitted in that envelope furnished by the Awarding Agency and the blank spaces on the envelope shall be filled in correctly to clearly indicate its contents. When an envelope other than the special one furnished by the Awarding Authority is used, it shall be marked to clearly indicate its contents. When sent by mail, the sealed proposal shall be addressed to the Awarding Authority at the address and in care of the official in whose office the bids are to be received. All proposals shall be filed prior to the time and at the place specified in the Notice to Bidders. Proposals received after the time specified will be returned to the bidder unopened.
9. Permission will be given to a bidder to withdraw a proposal if the bidder makes the request in writing or in person before the time for opening proposals.

RETURN WITH BID

PROPOSAL

County DuPage
 Local Public Agency Village of Villa Park
 Section Number N/A
 Route South Michigan Avenue

1. Proposal of _____

for the improvement of the above section by the construction of Roadway reconstruction; storm sewer installation; adjustment of drainage structures; sidewalk removal and replacement; parkway restoration; and other incidental and miscellaneous items of work.

a total distance of 1,882 feet, of which a distance of 1,882 feet, (0.356 miles) are to be improved.

2. The plans for the proposed work are those prepared by Baxter & Woodman, Inc. and approved by the Department of Transportation on N/A

3. The specifications referred to herein are those prepared by the Department of Transportation and designated as "Standard Specifications for Road and Bridge Construction" and the "Supplemental Specifications and Recurring Special Provisions" thereto, adopted and in effect on the date of invitation for bids.

4. The undersigned agrees to accept, as part of the contract, the applicable Special Provisions indicated on the "Check Sheet for Recurring Special Provisions" contained in this proposal.

5. The undersigned agrees to complete the work within 72 calendar days or by _____ unless additional time is granted in accordance with the specifications.

6. A proposal guaranty in the proper amount, as specified in BLRS Special Provision for Bidding Requirements and Conditions for Contract Proposals, will be required. Bid Bonds WILL be allowed as a proposal guaranty. Accompanying this proposal is either a bid bond if allowed, on Department form BLR 12230 or a proposal guaranty check, complying with the specifications, made payable to:

Village Treasurer of Villa Park

The amount of the check is Five percent (5%) of the bid amount (_____).

7. In the event that one proposal guaranty check is intended to cover two or more proposals, the amount must be equal to the sum of the proposal guaranties, which would be required for each individual proposal. If the proposal guaranty check is placed in another proposal, it will be found in the proposal for: Section Number N/A.

8. The successful bidder at the time of execution of the contract WILL be required to deposit a contract bond for the full amount of the award. When a contract bond is not required, the proposal guaranty check will be held in lieu thereof. If this proposal is accepted and the undersigned fails to execute a contract and contract bond as required, it is hereby agreed that the Bid Bond or check shall be forfeited to the Awarding Authority.

9. Each pay item should have a unit price and a total price. If no total price is shown or if there is a discrepancy between the product of the unit price multiplied by the quantity, the unit price shall govern. If a unit price is omitted, the total price will be divided by the quantity in order to establish a unit price.

10. A bid will be declared unacceptable if neither a unit price nor a total price is shown.

11. The undersigned submits herewith the schedule of prices on BLR 12200a covering the work to be performed under this contract.

12. The undersigned further agrees that if awarded the contract for the sections contained in the combinations on BLR 12200a, the work shall be in accordance with the requirements of each individual proposal for the multiple bid specified in the Schedule for Multiple Bids below.

RETURN WITH BID

CONTRACTOR CERTIFICATIONS

County	<u>DuPage</u>
Local Public Agency	<u>Village of Villa Park</u>
Section Number	<u>N/A</u>
Route	<u>South Michigan Avenue</u>

The certifications hereinafter made by the bidder are each a material representation of fact upon which reliance is placed should the Department enter into the contract with the bidder.

- Debt Delinquency.** The bidder or contractor or subcontractor, respectively, certifies that it is not delinquent in the payment of any tax administered by the Department of Revenue unless the individual or other entity is contesting, in accordance with the procedures established by the appropriate revenue Act, its liability for the tax or the amount of tax. Making a false statement voids the contract and allows the Department to recover all amounts paid to the individual or entity under the contract in a civil action.
- Bid-Rigging or Bid Rotating.** The bidder or contractor or subcontractor, respectively, certifies that it is not barred from contracting with the Department by reason of a violation of either 720 ILCS 5/33E-3 or 720 ILCS 5/33E-4.

A violation of Section 33E-3 would be represented by a conviction of the crime of bid-rigging which, in addition to Class 3 felony sentencing, provides that any person convicted of this offense or any similar offense of any state or the United States which contains the same elements as this offense shall be barred for 5 years from the date of conviction from contracting with any unit of State or local government. No corporation shall be barred from contracting with any unit of State or local government as a result of a conviction under this Section of any employee or agent of such corporation if the employee so convicted is no longer employed by the corporation and: (1) it has been finally adjudicated not guilty or (2) if it demonstrates to the governmental entity with which it seeks to contract and that entity finds that the commission of the offense was neither authorized, requested, commanded, nor performed by a director, officer or a high managerial agent in behalf of the corporation.

A violation of Section 33E-4 would be represented by a conviction of the crime of bid-rotating which, in addition to Class 2 felony sentencing, provides that any person convicted of this offense or any similar offense of any state or the United States which contains the same elements as this offense shall be permanently barred from contracting with any unit of State or local government. No corporation shall be barred from contracting with any unit of State or local government as a result of a conviction under this Section of any employee or agent of such corporation if the employee so convicted is no longer employed by the corporation and: (1) it has been finally adjudicated not guilty or (2) if it demonstrates to the governmental entity with which it seeks to contract and that entity finds that the commission of the offense was neither authorized, requested, commanded, nor performed by a director, officer or a high managerial agent in behalf of the corporation.

- Bribery.** The bidder or contractor or subcontractor, respectively, certifies that it has not been convicted of bribery or attempting to bribe an officer or employee of the State of Illinois or any unit of local government, nor has the firm made an admission of guilt of such conduct which is a matter of record, nor has an official, agent, or employee of the firm committed bribery or attempted bribery on behalf of the firm and pursuant to the direction or authorization of a responsible official of the firm.
- Interim Suspension or Suspension.** The bidder or contractor or subcontractor, respectively, certifies that it is not currently under a suspension as defined in Subpart I of Title 44 Subtitle A Chapter III Part 6 of the Illinois Administrative Code. Furthermore, if suspended prior to completion of this work, the contract or contracts executed for the completion of this work may be cancelled.

RETURN WITH BID

SIGNATURES
Addendum 2 - 4/29/2020

County DuPage
Local Public Agency Village of Villa Park
Section Number N/A
Route South Michigan Avenue

(If an individual)

Signature of Bidder _____

Business Address _____

(If a partnership)

Firm Name _____

Signed By _____

Business Address _____

Inset Names and Addressed of All Partners



(If a corporation)

Corporate Name United Enterprise, LLC

Signed By [Signature]
President

Business Address 9220 Ogden Ave. Ste. R.
Brookfield, IL 60513

Insert Names of Officers



President Pedro R. Ramirez

Secretary Alicia Ramirez

Treasurer N/A

Attest: Alicia Ramsey
Secretary

BIDDER ACKNOWLEDGES RECEIPT OF ADDENDUM 1 & 2:

[Signature] 5/13/20
SIGNED DATE

ADDENDUM NO.**1**

DATE: April 3, 2020
FROM: Village of Villa Park Public Works Department
TO: All Plan holders
PROJECT: **Michigan Avenue Improvement Project (Central to Kenilworth)**

The Bidding Documents for the subject project are hereby amended as follows.
The attached Acknowledgement Form must be filled out and returned with your Bid.

CHANGE THE FOLLOWING ITEM(S) IN THE SPECIFICATIONS:**IN "PAY ITEM 61":**

Replace Pay Item #61 with the following language:

"PAY ITEM #61 – SANITARY SEWER SERVICE REPLACEMENT

Description. This work shall be completed in accordance with the applicable portions of the latest edition of the "Standard Specifications for Water and Sewer Main Construction in Illinois" and the requirements of the Owner of the Sanitary Sewer, and shall consist of the repair of sanitary sewer building service lines when disturbed by other construction crossing the service line or as shown on the drawings, complete in place including CCTV inspection, root removal; excavation; bracing; trench dewatering; removal of existing building service lines; repair of service lines with PVC SDR 26 ASTM 2241 pipe and stainless steel non-shear mission couplings; bedding and covering of pipe; and trench backfilling with trench backfill materials. The materials used are to be in accordance with the specifications listed in the SANITARY SEWER SERVICE RECONNECTION special provision. This Pay Item will only be used for locations shown on the drawings or if the service is in direct conflict with new utilities being installed, as determined by the Engineer.

Basis of Payment. This work will be paid for at the contract unit price per foot for
SANITARY SEWER SERVICE REPLACEMENT regardless of pipe size."

IN "PAY ITEM 62":

Replace Pay Item #62 with the following language:

"PAY ITEM #62 – SANITARY SEWER SERVICE RECONNECTION

Description. This work shall consist of removing and replacing the existing sanitary sewer service tee/wye connection fittings at locations shown on the drawings or at other locations as deemed necessary by the Engineer. For sanitary service reconNECTIONS in conflict with proposed utilities, this item will only be paid for if the Engineer determines the sanitary service is in direct conflict with the utility being installed as a part of this project. If the contractor elects to reconnect the sanitary sewer service connection that the Engineer has not determined to be in direct conflict, that work will be paid for at the Contractor's expense. This work shall be done in accordance with the details included as part of the contract plans. The work shall be done in accordance with applicable portions of Section 563 of the Standard Specifications.

The Contractor shall install a new polyvinyl chloride wye or tee fitting at the location of the connection on the mainline sanitary sewer. The services shall be replaced from the new wye at the mainline sanitary sewer to the existing service pipe, using PVC pipe of the same diameter as the existing connection.

The Contractor is to coordinate with the Village 48 hours prior to disconnecting the existing sanitary sewer service. During this time, the Contractor is to ensure the residences are notified of any potential interruption in services. This work is incidental to this item. After the sanitary connection has been installed the Contractor shall be responsible for locating said sanitary connection lines for the remainder of the construction. The Village will not locate sanitary connections placed by the Contractor for the duration of the project. Any damage to the sanitary connection by the Contractor caused by the Contractor's failure to properly locate the sanitary connection shall be repaired by the Contractor at his own expense to the satisfaction of the Engineer.

563.02 Materials. The materials shall be in accordance with the applicable portions of Section 550 and 563 and the Sanitary Sewer System Specifications with the following exceptions:

Replacement sewer service material shall be Polyvinyl Chloride (PVC) pipe conforming to ASTM D-2241 with gasket joints conforming to ASTM D-3212 and a Standard Dimension Ratio (SDR) equal to 26. The wye fittings to be installed on the main shall be fabricated to fit the mainline pipe that conforms to ASTM D-3034 and the branch service pipe that conforms to ASTM D-2241. All supplied pipes must be from the same manufacturer. All supplied fittings must be from the same manufacturer. All connections to existing pipes shall be made with "FERNCO" RC

Series" or "MISSION Flex –Seal" adjustable non-shear repair couplings equipped with stainless steel bands. Additional fittings and labor required to connect the new 6-inch sanitary service pipe to existing service pipes that are a size other than six inches is incidental to this item.

Basis of Payment. This work will be paid for at the contract unit price for each SANITARY SEWER SERVICE RECONNECTION which price is to include all labor, equipment, excavation, saw cutting of pavement, materials, removal of existing connection, bypass pumping, removal of spoils, and reconnection of new pipe to existing pipe. If the sanitary sewer main or service pipe is required to be replaced as determined in the field by Engineer, the pipe will be paid for per linear foot as SANITARY SEWER PIPE, PVC SDR 26, ASTM D-2241, of the size specified or SANITARY SEWER SERVICE REPLACEMENT."

ADD THE FOLLOWING ATTACHMENTS TO THE CONTRACT:

1. Geotechnical Report (19 Pages)
2. LPC 663 (63 Pages)

END OF ADDENDUM NO. 1

RETURN WITH
BID

**ADDENDUM NO.
1
ACKNOWLEDGMENT
FORM**

I/We hereby acknowledge receipt of **ADDENDUM No. 1** to the Bidding Documents for the Village of Villa Park's **MICHIGAN AVENUE IMPROVEMENT PROJECT (CENTRAL TO KENILWORTH)**

Addendum No. 1
86 pages **TOTAL**

86 pages

Name: Pedro R. Ramirez

Title: President

Company: United Enterprise, LLC

Signature: 

Date: 5/13/2020

ADDENDUM NO. 2

DATE: April 29, 2020

FROM: Baxter & Woodman, Inc. Consulting Engineers

TO: Planholders of record for the Work titled

MICHIGAN AVENUE IMPROVEMENT PROJECT
(CENTRAL TO KENILWORTH)

The Bidding Documents are amended as follows:

1. SPECIAL PROVISIONS

- A. **Delete** the existing NOTICE TO BIDDERS (BLR 12200 - pg 2) in its entirety from the CONTRACT DOCUMENTS and **insert** the attached NOTICE TO BIDDERS. This revision changes the bid opening to May 15, 2020.
- B. **Delete** the existing SIGNATURE SHEET (BLR 12200 - pg 7) in its entirety from the CONTRACT DOCUMENTS and **insert** the attached SIGNATURE SHEET. This revision adds acknowledgement of Addendum No. 1 & 2.
- C. **Add** the following BIDDING REQUIREMENTS to the contract documents. This project will utilize grant funding in the sum of \$550,000.00 and is subject to Business Enterprise Program (BEP) requirements as defined by the State of Illinois Capital Development Board (CDB). These requirements are stated below. More information can be obtained at this link:
<https://www2.illinois.gov/cdb/business/Pages/MinorityWomenBusiness.aspx>

DBE CONTRACT GOAL TO BE ACHIEVED BY THE CONTRACTOR. This contract includes a specific DBE utilization goal. In the absence of unlawful discrimination and in an arena of fair and open competition, Minority/Disabled/Veteran owned businesses can be expected to perform 20% (\$110,000.00) and Women Business Enterprises can be expected to perform 5% (\$27,500.00) of the expected grant amount (\$550,000.00). The total DBE utilization amount shall be \$137,500.00. This percentage is set as the DBE participation goal for this contract. Consequently, in addition to the other award criteria established for this contract, the Village will only award this contract to a bidder who makes a good faith effort to meet this goal of DBE participation in the performance of the work. A bidder makes a good faith effort for award consideration if either of the following is done in accordance with the procedures set for in this Special Provision:

- (a) The bidder documents enough DBE participation has been obtained to meet the goal or,

- (b) The bidder documents a good faith effort has been made to meet the goal, even though the effort did not succeed in obtaining enough DBE participation to meet the goal.
- (c) These documentation efforts shall meet BEP requirements.

Nothing in this Addendum shall be construed as changing other requirements of the Bidding Documents. Each Bidder shall acknowledge receipt of this Addendum where indicated in the Bid Form.

END OF ADDENDUM NO. 2

Michigan Ave. Improvement Project (Central to Kenilworth)
 Route South Michigan Ave
 County DuPage
 Local Agency Village of Villa Park
 Section N/A

RETURN WITH BID

PAPER BID BOND

WE United Enterprise, LLC, 9220 Ogden Ave., Suite R, Brookfield, IL 60513 as PRINCIPAL,
 and Old Republic Surety Company as SURETY,

are held jointly, severally and firmly bound unto the above Local Agency (hereafter referred to as "LA") in the penal sum of 5% of the total bid price, or for the amount specified in the proposal documents in effect on the date of invitation for bids whichever is the lesser sum. We bind ourselves, our heirs, executors, administrators, successors, and assigns, jointly pay to the LA this sum under the conditions of this instrument.

WHEREAS THE CONDITION OF THE FOREGOING OBLIGATION IS SUCH that, the said PRINCIPAL is submitting a written proposal to the LA acting through its awarding authority for the construction of the work designated as the above section.

THEREFORE if the proposal is accepted and a contract awarded to the PRINCIPAL by the LA for the above designated section and the PRINCIPAL shall within fifteen (15) days after award enter into a formal contract, furnish surety guaranteeing the faithful performance of the work, and furnish evidence of the required insurance coverage, all as provided in the "Standard Specifications for Road and Bridge Construction" and applicable Supplemental Specifications, then this obligation shall become void; otherwise it shall remain in full force and effect.

IN THE EVENT the LA determines the PRINCIPAL has failed to enter into a formal contract in compliance with any requirements set forth in the preceding paragraph, then the LA acting through its awarding authority shall immediately be entitled to recover the full penal sum set out above, together with all court costs, all attorney fees, and any other expense of recovery.

IN TESTIMONY WHEREOF, the said PRINCIPAL and the said SURETY have caused this instrument to be signed by their respective officers this 15th day of May, 2020

Principal

United Enterprise, LLC
 (Company Name)
 By: [Signature] **PRESIDENT.**
 (Signature and Title)

 (Company Name)
 By: _____
 (Signature and Title)

(if PRINCIPAL is a joint venture of two or more contractors, the company names, and authorized signatures of each contractor must be affixed.)

Old Republic Surety Company
 (Name of Surety)

Surety

By: [Signature]
 (Signature of Attorney-in-Fact)
James I. Moore



STATE OF ILLINOIS,
 COUNTY OF DuPage
 I, Sherry Bacskai, a Notary Public in and for said county,
 do hereby certify that _____

& James I. Moore

(Insert names of individuals signing on behalf of PRINCIPAL & SURETY)

who are each personally known to me to be the same persons whose names are subscribed to the foregoing instrument on behalf of PRINCIPAL and SURETY, appeared before me this day in person and acknowledged respectively, that they signed and delivered said instruments as their free and voluntary act for the uses and purposes therein set forth.

Given under my hand and notarial seal this 15th day of May, 2020

My commission expires 10/22/2023

[Signature]
 (Notary Public)

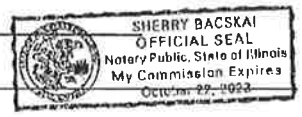

ELECTRONIC BID BOND

Electronic bid bond is allowed (box must be checked by LA if electronic bid bond is allowed)
 The Principal may submit an electronic bid bond, in lieu of completing the above section of the Proposal Bid Bond Form. By providing an electronic bid bond ID code and signing below, the Principal is ensuring the identified electronic bid bond has been executed and the Principal and Surety are firmly bound unto the LA under the conditions of the bid bond as shown above. (If PRINCIPAL is a joint venture of two or more contractors, an electronic bid bond ID code, company/Bidder name title and date must be affixed for each contractor in the venture.)

 Electronic Bid Bond ID Code

 (Company/Bidder Name)

 (Signature and Title)

 Date

★ OLD REPUBLIC SURETY COMPANY ★

POWER OF ATTORNEY

KNOW ALL MEN BY THESE PRESENTS: That OLD REPUBLIC SURETY COMPANY, a Wisconsin stock insurance corporation, does make, constitute and appoint:

James I. Moore

its true and lawful Attorney(s)-in-Fact, with full power and authority, not exceeding \$50,000,000, for and on behalf of the company as surety, to execute and deliver and affix the seal of the company thereto (if a seal is required), bonds, undertakings, recognizances or other written obligations in the nature thereof, (other than ball bonds, bank depository bonds, mortgage deficiency bonds, mortgage guaranty bonds, guarantees of installment paper and note guaranty bonds, self-insurance workers compensation bonds guaranteeing payment of benefits, asbestos abatement contract bonds, waste management bonds, hazardous waste remediation bonds or black lung bonds), as follows: Execution Date: May 1, 2020

Surety Bond number: Bid Bond
Principal: United Enterprise, LLC
Obligee: Village of Villa Park

and to bind OLD REPUBLIC SURETY COMPANY thereby, and all of the acts of said Attorneys-in-Fact, pursuant to these presents, are ratified and confirmed. This appointment is made under and by authority of the board of directors at a special meeting held on February 18, 1982.

This Power of Attorney is signed and sealed by facsimile under and by the authority of the following resolutions adopted by the board of directors of the OLD REPUBLIC SURETY COMPANY on February 18, 1982.

RESOLVED that, the president, any vice-president or assistant vice president, in conjunction with the secretary or any assistant secretary, may appoint attorneys-in-fact or agents with authority as defined or limited in the Instrument evidencing the appointment in each case, for and on behalf of the company to execute and deliver and affix the seal of the company to bonds, undertakings, recognizances, and suretyship obligations of all kinds; and said officers may remove any such attorney-in-fact or agent and revoke any Power of Attorney previously granted to such person.

RESOLVED FURTHER, that any bond, undertaking, recognizance, or suretyship obligation shall be valid and binding upon the Company

- (i) when signed by the president, any vice president or assistant vice president, and attested and sealed (if a seal be required) by any secretary or assistant secretary; or
- (ii) when signed by the president, any vice president or assistant vice president, secretary or assistant secretary, and countersigned and sealed (if a seal be required) by a duly authorized attorney-in-fact or agent; or
- (iii) when duly executed and sealed (if a seal be required) by one or more attorneys-in-fact or agents pursuant to and within the limits of the authority evidenced by the Power of Attorney issued by the company to such person or persons.

RESOLVED FURTHER that the signature of any authorized officer and the seal of the company may be affixed by facsimile to any Power of Attorney or certification thereof authorizing the execution and delivery of any bond, undertaking, recognizance, or other suretyship obligations of the company; and such signature and seal when so used shall have the same force and effect as though manually affixed.

IN WITNESS WHEREOF, OLD REPUBLIC SURETY COMPANY has caused these presents to be signed by its proper officer, and its corporate seal to be affixed this 1st day of October, 2018.

Assistant Secretary



OLD REPUBLIC SURETY COMPANY

President

STATE OF WISCONSIN, COUNTY OF WAUKESHA - SS

On this 1st day of October, 2018, personally came before me, Alan Pavlic and Jane E. Cherney, to me known to be the individuals and officers of the OLD REPUBLIC SURETY COMPANY who executed the above instrument, and they each acknowledged the execution of the same, and being by me duly sworn, did severally depose and say: that they are the said officers of the corporation aforesaid, and that the seal affixed to the above instrument is the seal of the corporation, and that said corporate seal and their signatures as such officers were duly affixed and subscribed to the said instrument by the authority of the board of directors of said corporation.



Notary Public

My Commission Expires: September 28, 2022

(Expiration of notary's commission does not invalidate this instrument)

CERTIFICATE

I, the undersigned, assistant secretary of the OLD REPUBLIC SURETY COMPANY, a Wisconsin corporation, CERTIFY that the foregoing and attached Power of Attorney remains in full force and has not been revoked; and furthermore, that the Resolutions of the board of directors set forth in the Power of Attorney, are now in force.

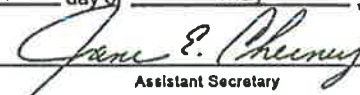

Signed and sealed at the City of Brookfield, WI this 15th day of May, 2020.

Assistant Secretary



Apprenticeship or Training Program Certification

Return with Bid

Route South Michigan Ave
County DuPage
Local Agency Village of Villa Park
Section N/A

All contractors are required to complete the following certification:

- For this contract proposal or for all groups in this deliver and install proposal.
For the following deliver and install groups in this material proposal:

Blank lines for listing subcontractor groups.

Illinois Department of Transportation policy, adopted in accordance with the provisions of the Illinois Highway Code, requires this contract to be awarded to the lowest responsive and responsible bidder. The award decision is subject to approval by the Department. In addition to all other responsibility factors, this contract or deliver and install proposal requires all bidders and all bidders' subcontractors to disclose participation in apprenticeship or training programs that are (1) approved by and registered with the United States Department of Labor's Bureau of Apprenticeship and Training, and (2) applicable to the work of the above indicated proposals or groups. Therefore, all bidders are required to complete the following certification:

- I. Except as provided in paragraph IV below, the undersigned bidder certifies that it is a participant, either as an individual or as part of a group program, in an approved apprenticeship or training program applicable to each type of work or craft that the bidder will perform with its own employees.
II. The undersigned bidder further certifies for work to be performed by subcontract that each of its subcontractors submitted for approval either (A) is, at the time of such bid, participating in an approved, applicable apprenticeship or training program; or (B) will, prior to commencement of performance of work pursuant to this contract, establish participation in an approved apprenticeship or training program applicable to the work of the subcontract.
III. The undersigned bidder, by inclusion in the list in the space below, certifies the official name of each program sponsor holding the Certificate of Registration for all of the types of work or crafts in which the bidder is a participant and that will be performed with the bidder's employees. Types of work or craft that will be subcontracted shall be included and listed as subcontract work. The list shall also indicate any type of work or craft job category for which there is no applicable apprenticeship or training program available.

Handwritten list of program sponsors: Laborers Union Local 2, Midwest Operating Engineers Local 150, Cement Masons Local 502

IV. Except for any work identified above, any bidder or subcontractor that shall perform all or part of the work of the contract or deliver and install proposal solely by individual owners, partners or members and not by employees to whom the payment of prevailing rates of wages would be required, check the following box, and identify the owner/operator workforce and positions of ownership.

The requirements of this certification and disclosure are a material part of the contract, and the contractor shall require this certification provision to be included in all approved subcontracts. The bidder is responsible for making a complete report and shall make certain that each type of work or craft job category that will be utilized on the project is accounted for and listed. The Department at any time before or after award may require the production of a copy of each applicable Certificate of Registration issued by the United States Department of Labor evidencing such participation by the contractor and any or all of its subcontractors. In order to fulfill the participation requirement, it shall not be necessary that any applicable program sponsor be currently taking or that it will take applications for apprenticeship, training or employment during the performance of the work of this contract or deliver and install proposal.

Bidder: United Enterprise, LLC
Address: 9220 Ogden Ave. Ste. 12.
Brookfield, IL 60513

By: 
(Signature)
Title: President

RETURN WITH BID



Affidavit of Illinois Business Office

County DuPage
Local Public Agency Village of Villa Park
Section Number N/A
Route South Michigan Avenue

State of Illinois)
County of Cook) ss.

I, Pedro R. Ramirez of Brookfield, Illinois
(Name of Affiant) (City of Affiant) (State of Affiant)

being first duly sworn upon oath, states as follows:

- 1. That I am the President of United Enterprise, LLC officer or position bidder
2. That I have personal knowledge of the facts herein stated.
3. That, if selected under this proposal, United Enterprise, LLC (bidder), will maintain a business office in the State of Illinois which will be located in Cook County, Illinois.
4. That this business office will serve as the primary place of employment for any persons employed in the construction contemplated by this proposal.
5. That this Affidavit is given as a requirement of state law as provided in Section 30-22(8) of the Illinois Procurement Code.

Signature of Pedro R. Ramirez
(Print Name of Affiant)

This instrument was acknowledged before me on 14 day of May, 2020.

(SEAL)



Signature of Notary Public

OWNER COPY

CONTRACT



Instructions: Complete this form by either typing or using black ink. "Authorization to Bid" will not be issued unless both sides of this form are completed in detail. Use additional forms as needed to list all work.

Part I. Work Under Contract

List below all work you have under contract as either a prime contractor or a subcontractor. It is required to include all pending low bids not yet awarded or rejected. In a joint venture, list only that portion of the work which is the responsibility of your company. The uncompleted dollar value is to be based upon the most recent engineer's or owners estimate, and must include work subcontracted to others. If no work is contracted, show NONE.

	1	2	3	4	Awards Pending	Accumulated Totals
Contract Number	U-9-174	S-9-701	S-9-704	36880		
Contract With	CDOT	CDOT/G&V	CDOT/G&V	DWM/ BMC		
Estimated Completion Date	2021	2020	2020	2021		
Total Contract Price	3,156,100.00	343,296.00	343,296.00	2,968,816.46		
Uncompleted Dollar Value if Firm is the Prime Contractor	1,039,985.57	0.00	0.00	0.00		1,039,985.57
Uncompleted Dollar Value if Firm is the Subcontractor	0.00	118,906.81	317,955.80	1,584,408.23		2,021,270.84
Total Value of All Work						3,061,256.41

Part II. Awards Pending and Uncompleted Work to be done with your own forces.

List below the uncompleted dollar value of work for each contract and awards pending to be completed with your own forces. All work subcontracted to others will be listed on the reverse of this form. In a joint venture, list only that portion of the work to be done by your company. If no work is contracted, show NONE.

					Accumulated Totals	
Earthwork					0.00	
Portland Cement Concrete Paving					0.00	
HMA Plant Mix					0.00	
HMA Paving					0.00	
Clean & Seal Cracks/Joints					0.00	
Aggregate Bases & Surfaces					0.00	
Highway, R.R. and Waterway Structures					0.00	
Drainage				1,584,408.23	1,584,408.23	
Electrical					0.00	
Cover and Seal Coats					0.00	
Concrete Construction	1,039,985.57	118,906.81	317,955.80		1,476,848.18	
Landscaping					0.00	
Fencing					0.00	
Guardrail					0.00	
Painting					0.00	
Signing					0.00	
Cold Milling, Planning & Rotomilling					0.00	
Demolition					0.00	
Pavement Markings (Paint)					0.00	
Other Construction (List)					0.00	
					0.00	
					0.00	
Totals	1,039,985.57	118,906.81	317,955.80	1,584,408.23	0.00	3,061,256.41

Disclosure of this information is **REQUIRED** to accomplish the statutory purpose as outlined in the "Illinois Procurement Code". Failure to comply will result in non-issuance of an "Authorization To Bid." This form has been approved by the State Forms Management Center.



Illinois Department of Transportation

Bureau of Construction
2300 South Dirksen Parkway/Room 322
Springfield, Illinois 62764

Affidavit of Availability
For the Letting of 4/24/2020
(Letting date)

CONTRACT

Instructions: Complete this form by either typing or using black ink. "Authorization to Bid" will not be issued unless both sides of this form are completed in detail. Use additional forms as needed to list all work.

Part I. Work Under Contract

List below all work you have under contract as either a prime contractor or a subcontractor. It is required to include all pending low bids not yet awarded or rejected. In a joint venture, list only that portion of the work which is the responsibility of your company. The uncompleted dollar value is to be based upon the most recent engineer's or owners estimate, and must include work subcontracted to others. If no work is contracted, show NONE.

	1	2	3	4	Awards Pending
Contract Number	D3 - 38084 (extension) DMM	D4 - 38085 (extension) DMM	D5 - 38150 (extension) DMM	D6 - 38151 (extension) DMM	
Contract With	Benchmark	Benchmark	Benchmark	Benchmark	
Estimated Completion Date	2020	2020	2020	2020	
Total Contract Price	3,000,890.00	845,370.00	4,200,000.00	2,800,390.00	Accumulated Totals
Uncompleted Dollar Value if Firm is the Prime Contractor					1,039,986.57
Uncompleted Dollar Value if Firm is the Subcontractor	0.00	0.00	203,729.27	56,167.05	2,281,167.18
Total Value of All Work					3,321,142.73

Part II. Awards Pending and Uncompleted Work to be done with your own forces.

List below the uncompleted dollar value of work for each contract and awards pending to be completed with your own forces. All work subcontracted to others will be listed on the reverse of this form. In a joint venture, list only that portion of the work to be done by your company. If no work is contracted, show NONE.

					Accumulated Totals
Earthwork					0.00
Portland Cement Concrete Paving					0.00
HMA Plant Mix					0.00
HMA Paving					0.00
Clean & Seal Cracks/Joints					0.00
Aggregate Bases & Surfaces					0.00
Highway,R.R. and Waterway Structures					0.00
Drainage					1,584,408.23
Electrical					0.00
Cover and Seal Coats					0.00
Concrete Construction					1,476,848.18
Landscaping					0.00
Fencing					0.00
Guardrail					0.00
Painting					0.00
Signing					0.00
Cold Milling, Planing & Rotomilling					0.00
Demolition					0.00
Pavement Markings (Paint)					0.00
Other Construction (List)					0.00
Water Main Services			203,729.27	56,167.05	259,896.32
					0.00
Totals	0.00	0.00	203,729.27	56,167.05	0.00
					3,321,142.73

Disclosure of this information is REQUIRED to accomplish the statutory purpose as outlined in the "Illinois Procurement Code". Failure to comply will result in non-issuance of an "Authorization To Bid." This form has been approved by the State Forms Management Center.



Illinois Department of Transportation

Bureau of Construction
2300 South Dirksen Parkway/Room 322
Springfield, Illinois 62764

Affidavit of Availability
For the Letting of CONTRACT
4/24/2020
(Letting date)

Instructions: Complete this form by either typing or using black ink. "Authorization to Bid" will not be issued unless both sides of this form are completed in detail. Use additional forms as needed to list all work.

Part I. Work Under Contract

List below all work you have under contract as either a prime contractor or a subcontractor. It is required to include all pending low bids not yet awarded or rejected. In a joint venture, list only that portion of the work which is the responsibility of your company. The uncompleted dollar value is to be based upon the most recent engineer's or owners estimate, and must include work subcontracted to others. If no work is contracted, show **NONE**.

	1	2	3	4	Awards Pending	
Contract Number	19-624	19-623				
Contract With	DWM/ G&V Construction	DWM/ MAT Construction				
Estimated Completion Date	2022	2022				
Total Contract Price	1,741,000.00	6,900,000.00				Accumulated Totals
Uncompleted Dollar Value if Firm is the Prime Contractor						1,039,986.57
Uncompleted Dollar Value if Firm is the Subcontractor	1,725,600.00	6,870,950.00				10,877,707.16
Total Value of All Work						11,917,692.73

Part II. Awards Pending and Uncompleted Work to be done with your own forces.

List below the uncompleted dollar value of work for each contract and awards pending to be completed with your own forces. All work subcontracted to others will be listed on the reverse of this form. In a joint venture, list only that portion of the work to be done by your company. If no work is contracted, show **NONE**.

						Accumulated Totals
Earthwork						0.00
Portland Cement Concrete Paving						0.00
HMA Plant Mix						0.00
HMA Paving						0.00
Clean & Seal Cracks/Joints						0.00
Aggregate Bases & Surfaces						0.00
Highway, R.R. and Waterway Structures						0.00
Drainage	1,725,600.00	6,870,950.00				10,180,858.23
Electrical						0.00
Cover and Seal Coats						0.00
Concrete Construction						1,476,848.18
Landscaping						0.00
Fencing						0.00
Guardrail						0.00
Painting						0.00
Signing						0.00
Cold Milling, Planning & Rotomilling						0.00
Demolition						0.00
Pavement Markings (Paint)						0.00
Other Construction (List)						0.00
						259,866.32
						0.00
Totals	1,725,600.00	6,870,950.00	0.00	0.00	0.00	11,917,692.73

Disclosure of this information is **REQUIRED** to accomplish the statutory purpose as outlined in the "Illinois Procurement Code". Failure to comply will result in non-issuance of an "Authorization To Bid." This form has been approved by the State Forms Management Center.

Part III. Work Subcontracted to Others

For each contract described in Part I, list all the work you have subcontracted to others.

	1	2	3	4	Awards Pending
Subcontractor	—	—	—	—	—
Type of Work					
Subcontract Price					
Amount Uncompleted					
Subcontractor					
Type of Work					
Subcontract Price					
Amount Uncompleted					
Subcontractor					
Type of Work					
Subcontract Price					
Amount Uncompleted					
Subcontractor					
Type of Work					
Subcontract Price					
Amount Uncompleted					
Subcontractor					
Type of Work					
Subcontract Price					
Amount Uncompleted					
Subcontractor					
Type of Work					
Subcontract Price					
Amount Uncompleted					
Subcontractor					
Type of Work					
Subcontract Price					
Amount Uncompleted					
Total Uncompleted	0.00	0.00	0.00	0.00	0.00

I, being duly sworn, do hereby declare this affidavit is a true and correct statement relating to ALL uncompleted contracts of the undersigned for Federal, State, County, City and private work, including ALL subcontract work, ALL pending low bids not yet awarded or rejected and ALL estimated completion dates

Subscribed and sworn to before me

this 5 day of May, 2020.

Raymundo Ramirez
Notary Public

My commission expires: May 31 2022

(Notary Seal)



Type or Print Name Pedro R. Ramirez President

Officer or Director Title

Signed [Signature]

Company United Enterprise, LLC

Address 9220 Ogden Ave. Ste. 12.
Brookfield, IL 60513

**MICHIGAN AVENUE IMPROVEMENT PROJECT
(CENTRAL TO KENILWORTH)
VILLAGE OF VILLA PARK**

INDEX OF SPECIAL PROVISIONS

TITLE	PAGE NO.
SPECIAL PROVISIONS	1
DEFINITIONS	1
LOCATION OF PROJECT	1
DESCRIPTION OF PROJECT	1
GENERAL SPECIAL PROVISIONS	3
QUALIFICATIONS OF BIDDERS.....	3
BID PRICE LIMITATIONS.....	5
BIDS TO REMAIN SUBJECT TO ACCEPTANCE	6
SUBCONTRACTORS	6
INSURANCE	6
INCREASED OR DECREASED QUANTITIES	7
MOBILIZATION	7
WINTER WORK.....	7
PORTABLE TOILET.....	7
WORKING HOURS.....	8
HOLIDAYS	8
PUBLIC CONVENIENCE AND SAFETY (D-1).....	8
OPERATION OF WATER DISTRIBUTION FACILITIES	9
CONSTRUCTION SAFETY AND HEALTH STANDARDS.....	9
FINAL INSPECTION	9
MAINTENANCE WARRANTY.....	10
MAINTENANCE OF ROADWAYS	10
KEEPING ROADS OPEN TO TRAFFIC	11
TEST STRIPS	11
RESPONSIBILITY FOR VANDALISM.....	11

**MICHIGAN AVENUE IMPROVEMENT PROJECT
(CENTRAL TO KENILWORTH)
VILLAGE OF VILLA PARK**

USE OF FIRE HYDRANTS 12

TRENCH BACKFILL AND PIPE BEDDING 13

EXCAVATION AND BACKFILLING OF DRAINAGE AND UTILITY STRUCTURES.... 13

ADJUSTING RINGS..... 13

SALVAGE AND DISPOSAL OF EXISTING MATERIALS 14

FRAMES, GRATES AND LIDS 14

DATE OF MANUFACTURE 15

IRON AND STEEL MATERIALS 15

PROTECTION OF EXISTING DRAINAGE FACILITIES DURING CONSTRUCTION... 15

DROP HAMMERS..... 16

AVAILABLE REPORTS..... 16

STATUS OF UTILITIES (D-1) 17

PAY ITEM SPECIAL PROVISIONS..... 20

PAY ITEM #2 – STUMP REMOVAL..... 20

PAY ITEM #3 – TREE PROTECTION FENCING 20

PAY ITEM #4 – TREE ROOT PRUNING 20

PAY ITEM #5-6 – TREE PRUNING 21

PAY ITEM #7 – TREES..... 21

PAY ITEM #12 – PARKWAY RESTORATION 23

PAY ITEM #14 – INLET FILTERS..... 24

PAY ITEM #15 – AGGREGATE SUBGRADE IMPROVEMENT 25

PAY ITEM #17 – BITUMINOUS MATERIALS (TACK COAT)..... 27

PAY ITEM #21 – HOT-MIX ASPHALT DRIVEWAY PAVEMENT 28

PAY ITEM #22 – PORTLAND CEMENT CONCRETE DRIVEWAY PAVEMENT 28

PAY ITEM #23 – PORTLAND CEMENT CONCRETE SIDEWALK..... 29

PAY ITEM #24 – DETECTABLE WARNINGS 29

PAY ITEM #25 – PAVEMENT REMOVAL 30

PAY ITEM #26 – DRIVEWAY PAVEMENT REMOVAL 30

PAY ITEM #28 – SIDEWALK REMOVAL..... 30

**MICHIGAN AVENUE IMPROVEMENT PROJECT
(CENTRAL TO KENILWORTH)
VILLAGE OF VILLA PARK**

PAY ITEM #29-32 – STORM SEWERS, RUBBER GASKET..... 31

PAY ITEM #33 – STORM SEWER RESTRICTOR 31

PAY ITEM #34 – STORM SEWER (WATER MAIN REQUIREMENTS)..... 32

PAY ITEM #37-40 – CATCH BASINS, MANHOLES, AND INLETS 32

PAY ITEM #51 – WATER VALVES..... 32

PAY ITEM #53 – FIRE HYDRANTS TO BE REMOVED 34

PAY ITEM #54 – FIRE HYDRANT WITH AUXILIARY VALVE AND VALVE BOX 35

PAY ITEM #55-56 – WATER SERVICE CONNECTION..... 37

PAY ITEM #58 – ADJUSTING WATER SERVICE LINES 39

PAY ITEM #59 – WATER MAIN RELOCATION 41

PAY ITEM #60 – CONNECTION TO EXISTING WATER MAIN 41

PAY ITEM #61 – SANITARY SEWER SERVICE REPLACEMENT 42

PAY ITEM #62 – SANITARY SEWER SERVICE RECONNECTION 43

PAY ITEM #63 – SANITARY SEWER PIPE, PVC SDR 26 ASTM D-2241 44

PAY ITEM #64 – SANITARY MANHOLES..... 44

PAY ITEM #65 – SANITARY SEWER SERVICE COMBINATION CLEANOUT CHECK VALVE..... 45

PAY ITEM #66 – ADJUSTING SANITARY SEWER SERVICE LINE..... 46

PAY ITEM #68 – TRAFFIC CONTROL AND PROTECTION (SPECIAL)..... 47

PAY ITEM #71 – DUST CONTROL WATERING 48

PAY ITEM #72 – WATER SERVICE INVESTIGATION 48

PAY ITEM #73 – SANITARY SERVICE INVESTIGATION 49

PAY ITEM #74 – EXPLORATION TRENCH, SPECIAL 49

PAY ITEM #75 – AGGREGATE TEMPORARY ACCESS (PRIVATE ENTRANCE) 50

PAY ITEM #76 – HOT-MIX ASPHALT TEMPORARY ACCESS (ROAD) 51

PAY ITEM #77 – SANITARY MANHOLES TO BE ADJUSTED 52

PAY ITEM #78 – COMBINATION CONCRETE CURB AND GUTTER, TYPE B-6.12 (SPECIAL)..... 53

PAY ITEM #81 – PRE-CONSTRUCTION VIDEO RECORDING 55

PAY ITEM #82 – POST-CONSTRUCTION SEWER TELEVISIONING..... 58

PAY ITEM #83 – WATER USAGE DEDUCTION..... 59

**MICHIGAN AVENUE IMPROVEMENT PROJECT
(CENTRAL TO KENILWORTH)
VILLAGE OF VILLA PARK**

PAY ITEM #84 – WATER USAGE CREDIT 59
PAY ITEM #85 – CONTINGENCY ALLOWANCE 60
DRAINAGE AND INLET PROTECTION UNDER TRAFFIC (DISTRICT 1)..... 62
COARSE AGGREGATE FOR BACKFILL, TRENCH BACKFILL AND BEDDING (D-1) 63
HOT-MIX ASPHALT BINDER AND SURFACE COURSE (D-1) 64
GROUND TIRE RUBBER (GTR) MODIFIED ASPHALT BINDER (D-1) 73
FRICTION AGGREGATE (D-1) 75
RECLAIMED ASPHALT PAVEMENT AND RECLAIMED ASPHALT SHINGLES (D-1) 77

APPENDIX A – ORDINANCE AMENDING THE REQUIREMENTS OF BIDDERS FOR
CONSTRUCTION PROJECTS

APPENDIX B – RECOMMENDED CONTRACTUAL INSURANCE GUIDELINES

**MICHIGAN AVENUE IMPROVEMENT PROJECT
(CENTRAL TO KENILWORTH)
VILLAGE OF VILLA PARK****SPECIAL PROVISIONS**

The following Special Provisions supplement the "Standard Specifications for Road and Bridge Construction", adopted April 1, 2016 (referred to hereinafter as the Standard Specifications); the "Supplemental Specifications and Recurring Special Provisions", adopted January 1, 2018; the latest edition of the "Illinois Manual on Uniform Traffic Control Devices For Streets and Highways" (IMUTCD); and the "Standard Specifications for Water and Sewer Construction in Illinois", 7th Edition, 2014 (referred to hereinafter as the Water and Sewer Specifications). In case of conflict with any part or parts of said Specifications, these Special Provisions shall take precedence and shall govern. Where no conflict exists, the said Specifications shall apply to this Contract as if repeated in their entirety herein.

DEFINITIONS

Contractor. The individual, firm, partnership, joint venture, or corporation contracting with the Village of Villa Park for performance of prescribed work.

Department, Owner or Village. The Village of Villa Park, DuPage County, Illinois.

Engineer. The Resident Engineer who is the authorized representative of the Village of Villa Park in immediate charge of the engineering details of a construction project.

LOCATION OF PROJECT

The project is located on South Michigan Avenue from West Central Boulevard to West Kenilworth Avenue in the Village of Villa Park, DuPage County, Illinois. A location map is shown on the cover of the Plans.

DESCRIPTION OF PROJECT

The work consists of furnishing all labor, materials, equipment, and other incidentals necessary for the completion of roadway reconstruction; storm sewer installation; sanitary sewer repairs; water main service adjustment; sidewalk repair; parkway restoration; and other incidental and miscellaneous items of work in accordance with the Plans, Standard Specifications, and these Special Provisions.

**MICHIGAN AVENUE IMPROVEMENT PROJECT
(CENTRAL TO KENILWORTH)
VILLAGE OF VILLA PARK**

This page intentionally left blank

**MICHIGAN AVENUE IMPROVEMENT PROJECT
(CENTRAL TO KENILWORTH)
VILLAGE OF VILLA PARK**

GENERAL SPECIAL PROVISIONS

QUALIFICATIONS OF BIDDERS

Bidders will comply with all applicable Federal, State and local laws and requirements, and will further meet the qualifications prescribed in this and other applicable portions of these provisions.

Bidder, in submitting a Bid, certifies that Bidder is in compliance with all applicable Federal, State and local laws and requirements, and that Bidder further meets the qualifications prescribed in this and other applicable portions of these provisions. Engineer's determination as to the compliance and qualifications of the Bidder will be final, and Bidder, in submitting a Bid, agrees to be bound by that determination.

Bidder, in submitting a Bid, certifies that Bidder is in compliance with the following requirements and qualifications. Bidder further certifies that Bidder is able to provide written evidence of Bidder's compliance with the following requirements and qualifications. Bidder shall, upon request by Engineer, submit such written evidence within five (5) calendar days of the Engineer's request, as well as any other written evidence which Engineer may deem necessary for the purpose of evaluating Bidder's qualifications.

- (a) Bidder shall be qualified to do business in the State of Illinois.
- (b) Bidder shall possess either a valid Federal Employer Tax Identification Number (FEIN) or a valid Social Security Number (SSN).
- (c) Bidder shall be able to provide a street address and description of the Bidder's place of business, and the mailing address of the business, if different from the street address.
- (d) Bidder shall be able to provide the number of years Bidder has been engaged in the contracting business under the present firm name, and the name of the state where incorporated.
- (e) Bidder shall be able to provide a list of the property and equipment available to the Bidder.
- (f) Bidder shall be able to provide a financial statement demonstrating that the Bidder has the financial resources to meet all obligations related to the Work.
- (g) Bidder shall maintain insurance policies with the coverages required by the Contract, and with the minimum limits of coverage required by the Contract. Bidder shall be able to provide current certificate(s) of insurance for the

**MICHIGAN AVENUE IMPROVEMENT PROJECT
(CENTRAL TO KENILWORTH)
VILLAGE OF VILLA PARK**

insurance policies held by Bidder, demonstrating that Bidder holds insurance policies with the coverages required by the contract, and with the minimum limits of coverage required by the Contract.

- (h) Bidder shall have constructed a minimum of three (3) projects of a similar nature in the immediate past five (5) years. Bidder shall be able to provide a list of all projects of a similar nature constructed by Bidder in the immediate past five (5) years, which list shall contain the minimum of three (3) such projects, which list shall provide a description and the location(s) of all such projects, and shall contain the Bidder's performance record and references, as well as the names and current contact information, including addresses and telephone numbers, of persons who acted as owners' representatives for those projects and who have knowledge of those projects, and whom Bidder agrees the Village may contact for the purpose of verifying Bidder's performance and references.
- (i) Bidder shall be able to provide a list of three (3) references (name, address and telephone number) with knowledge of the integrity and business practices of the bidder. Such references may not be persons who have been employed by Bidder as employees.
- (j) Bidder shall be able to provide a list of projects presently under Contract, the awarded Contract amount of each, the approximate adjusted Contract amount of each (if applicable), and the dollar amount or percent of completion of each.
- (k) Bidder shall be able to provide a list of Contracts which have resulted in lawsuits, whether against Bidder as a prime contractor, against Bidder as a subcontractor, or against Bidder as a party in any other capacity; or against subcontractors or suppliers performing work for Bidder or under Contract held by Bidder.
- (l) Bidder shall be able to provide a list of Contracts defaulted.
- (m) Bidder shall be able to provide a statement indicating whether or not Bidder has ever filed bankruptcy.
- (n) Bidder shall be able to provide a list of all officers of the firm, which list shall also indicate those officers who, while in the employ of the firm or in the employ of previous firms, were associated with Contracts which resulted in lawsuits, Contracts defaulted, or firms which filed for bankruptcy.
- (o) Bidder shall maintain personnel guaranteed to be employed in the responsible charge of the Work, which personnel possess sufficient technical experience to ensure the satisfactory completion of the Work. Bidder shall be

**MICHIGAN AVENUE IMPROVEMENT PROJECT
(CENTRAL TO KENILWORTH)
VILLAGE OF VILLA PARK**

able to provide the names and technical experience of such personnel, as well as statements as to whether the personnel have or have not performed satisfactorily on other contracts of like nature and magnitude or comparable difficulty at similar rate of progress.

- (p) Bidder shall be able to provide a list of subcontractors and suppliers anticipated to be employed by Bidder for the purpose of completing the Work, including the firm name, street address and description of place of business; mailing address of business (if different); phone, fax and e-mail contact information of business; name of primary contact; and a list of any projects or contracts for which Bidder currently owes monies to said firm, which list shall include a description of the project or contract, the amount currently due to said firm, the period of time for which those monies have been owed, and the expected date of payment of those monies.
- (q) Bidder shall participate in active apprenticeship and training programs approved by and registered with the United States Department of Labor Bureau of Apprenticeship and Training for each of the trades of work contemplated under the Contract. Bidder shall be able to provide evidence of Bidder's participation in such apprenticeship and training programs.
- (r) Bidder shall only employ subcontractors who meet the requirements prescribed in this section and other sections of these specifications.
- (s) Bidder shall be able to provide such other information as may assist the Village in determining whether the Bidder is adequately prepared to fulfill the Contract.

These requirements and qualifications are not intended to discourage bidding, to make it difficult for qualified Bidders to submit Bids, or to discourage beginning contractors. The purpose of these requirements and qualifications is to allow the Village to obtain sufficient information about Bidder's financial state, available equipment, personnel, and previous work experience so that the Village may mitigate the hazards involved in awarding contracts to parties who may not be qualified to perform the Work as specified.

A copy of Village of Villa Park Ordinance No. 3733, amending the requirements of bidders for construction projects, is provided as Appendix A.

BID PRICE LIMITATIONS

The bid price for TRAFFIC CONTROL AND PROTECTION (SPECIAL) shall not exceed 5 percent of the total bid price. If the bid price for TRAFFIC CONTROL AND

**MICHIGAN AVENUE IMPROVEMENT PROJECT
(CENTRAL TO KENILWORTH)
VILLAGE OF VILLA PARK**

PROTECTION (SPECIAL) exceeds 5 percent of the total bid price, the Village may reject the Bid.

The bid price for CONSTRUCTION LAYOUT shall not exceed 2 percent of the total bid price. If the bid price for CONSTRUCTION LAYOUT exceeds 2 percent of the total bid price, the Village may reject the Bid.

The bid price for PRE-CONSTRUCTION VIDEO RECORDING shall not exceed 1 percent of the total bid price. If the bid price for PRE-CONSTRUCTION VIDEO RECORDING exceeds 1 percent of the total bid price, the Village may reject the Bid.

Bidder, in submitting a Bid, certifies that the Bid is in compliance with these requirements. The Village's determination as to whether or not to reject a Bid that does not comply with these requirements will be final, and Bidder, in submitting a Bid, agrees to be bound by that determination.

BIDS TO REMAIN SUBJECT TO ACCEPTANCE

All bids shall remain subject to acceptance by the Village for a period of 90 calendar days from the date of the bid opening. The Village may extend the acceptance period by up to an additional 60 calendar days upon written notice to all bidders by the Village. The Village may, in its sole discretion, release any bid and return the bid bond prior to the end of the acceptance period.

SUBCONTRACTORS

Add the following paragraph to the end of Article 108.01 of the Standard Specifications:

"The apparent low Bidder shall submit to the Village within 7 calendar days after the receipt of bids, a list of the names of Bidder's proposed subcontractors and material suppliers along with a description of the work to be performed or the materials to be supplied by each."

INSURANCE

Insurance and indemnification shall be in accordance with applicable sections of the Standard Specifications, and shall also be in accordance with the "IRMA Contractual Insurance Guidelines", incorporated herein as Appendix B. If a conflict is determined to exist between the requirements prescribed in the Standard Specifications and the requirements prescribed in the IRMA Contractual Insurance Guidelines, such conflict will be resolved as follows:

**MICHIGAN AVENUE IMPROVEMENT PROJECT
(CENTRAL TO KENILWORTH)
VILLAGE OF VILLA PARK**

- a. If a particular type of insurance coverage is required by one standard but not by both, that type of insurance coverage will be required.
- b. If the minimum limits of insurance coverage required by one standard differ from those required by the other standard, the higher minimum limits of insurance coverage will prevail.
- c. If any other conflicts are determined to exist between the requirements prescribed in the two standards, the stricter of the two requirements will prevail. The Village will make the final determination as to what constitutes a stricter requirement.

INCREASED OR DECREASED QUANTITIES

The Village reserves the right to increase or decrease the amount of work shown in the plans in accordance with Section 109 of the Standard Specifications.

MOBILIZATION

Mobilization shall be in accordance with Section 671 of the Standard Specifications, except as modified herein.

Revise Article 671.02, Basis of Payment, to read:

“671.02 Basis of Payment. This work will not be paid for separately but shall be included in the unit bid prices of the items for which this work applies.”

WINTER WORK

If Contractor elects to begin any site work before or during winter, no additional compensation will be granted for any costs or delays incurred by the Contractor as a result of winter weather. The Contractor shall be responsible for the implementation and cost of any winter shutdown provisions which are deemed necessary by the Engineer.

PORTABLE TOILET

Contractor shall furnish a portable toilet meeting Federal, State and local health department requirements stocked with lavatory and sanitary supplies at all times. The portable toilet shall be provided at a location approved by the Engineer. The portable toilet shall be maintained in a clean and sanitary condition and shall be emptied as

**MICHIGAN AVENUE IMPROVEMENT PROJECT
(CENTRAL TO KENILWORTH)
VILLAGE OF VILLA PARK**

needed. This work will not be paid for separately but shall be included in the cost of the contract.

WORKING HOURS

Working hours will be between 7:00 A.M. and 5:00 P.M., Monday through Friday, excluding holidays as designated by the Contract.

Contractor will not permit the performance of Work outside these working hours without Owner's written consent, which may be given after prior written request to Engineer, except as otherwise required for the safety of persons or the Work or property at the Site or adjacent thereto, and except as otherwise stated in the Contract Documents.

If Contractor permits the performance of Work outside these working hours, Contractor will compensate Owner for the costs of inspection and other services provided by Engineer. Owner will determine the rates at which such inspection and other services are to be compensated. Owner will determine the interval or intervals at which billing will take place, and may, at Owner's discretion, submit invoices for payment to Contractor, or deduct the costs from any monies due or to become due to the Contractor from Owner.

HOLIDAYS

Revise the list of legal holidays in Article 107.09 of the Standard Specifications to read:

- | | |
|------------------|----------------------------|
| New Year's Day | Thanksgiving Day |
| Easter | <u>Thanksgiving Friday</u> |
| Memorial Day | <u>Christmas Eve</u> |
| Independence Day | Christmas Day |
| Labor Day | <u>New Year's Eve</u> |

PUBLIC CONVENIENCE AND SAFETY (D-1)

Effective: May 1, 2012
Revised: July 15, 2012

Add the following to the end of the fourth paragraph of Article 107.09:

"If the holiday is on a Saturday or Sunday, and is legally observed on a Friday or Monday, the length of Holiday Period for Monday or Friday shall apply."

**MICHIGAN AVENUE IMPROVEMENT PROJECT
(CENTRAL TO KENILWORTH)
VILLAGE OF VILLA PARK**

Add the following sentence after the Holiday Period table in the fourth paragraph of Article 107.09:

“The Length of Holiday Period for Thanksgiving shall be from 5:00 AM the Wednesday prior to 11:59 PM the Sunday After”

Delete the fifth paragraph of Article 107.09 of the Standard Specifications:

“On weekends, excluding holidays, on roadways with Average Daily Traffic of 25,000 or greater, all lanes shall be open to traffic from 3:00 P.M. Friday to midnight Sunday except where structure construction or major rehabilitation makes it impractical.”

OPERATION OF WATER DISTRIBUTION FACILITIES

Contractor shall not operate any water distribution facilities, including, but not limited to, valves or hydrants. If Contractor requires the operation of such facilities, Contractor shall provide a minimum of 48 hours' notice to the Village and the Village will operate such facilities.

CONSTRUCTION SAFETY AND HEALTH STANDARDS

It is a condition of this contract and shall be made a condition of each subcontract entered into pursuant to this contract that the Contractor and any Subcontractor shall not require any laborer or mechanic employed in performance of that contract to work in surroundings or under working conditions which are unsanitary, hazardous or dangerous to their health or safety, as determined under Federal Construction Safety and Health Standards.

FINAL INSPECTION

Final inspection shall be in accordance with Article 105.13 of the Standard Specifications, except as modified herein.

Revise the second paragraph of Article 105.13, Final Inspection, to read:

“If the inspection discloses any work, in whole or in part, as being unsatisfactory, the Engineer will give the Contractor the necessary instructions for correction of same, and the Contractor shall comply with such instructions within 14 calendar days of receipt of such instructions. The Contractor shall give the Engineer not less than 48 hours notice, in writing, prior to beginning any such corrective work. Upon completion of all corrective work, the Contractor shall give the Engineer notice in writing. Upon receipt of such

**MICHIGAN AVENUE IMPROVEMENT PROJECT
(CENTRAL TO KENILWORTH)
VILLAGE OF VILLA PARK**

notice, the Engineer will make another inspection which shall constitute the final inspection provided the work has been satisfactorily completed. In such event, the Engineer will notify the Contractor in writing of the date of final inspection.”

MAINTENANCE WARRANTY

The Contractor shall execute and deliver to the Village, before final payment will be issued, a written warranty, in a form satisfactory to the Village, which guarantees that all work is in accordance with the contract and will not be defective. This warranty shall guarantee all work for a period of 1 year from the date of final inspection.

The Contractor shall furnish a warranty bond in an amount equal to 10 percent of the final contract amount, or \$100,000.00, whichever is greater, by a surety satisfactory to the Village to guarantee Contractor’s warranty to repair defective work.

If, within the warranty period, the Village determines any work to be defective, a written notice of such deficiency will be sent to the Contractor by certified mail.

The Contractor shall, within 14 calendar days of receipt of the notice of deficiency, and without cost to the Village, correct or repair such defective work, or remove and replace the defective work in accordance with the contract requirements for the item or items in question.

If Contractor desires an extension of time to complete the corrective work, Contractor shall make such request in writing within 10 calendar days of receipt of the notice of deficiency. After the Contractor has filed a request for an extension of time, the Village will notify the Contractor, in writing, whether or not such extension will be approved.

Should the Contractor fail to complete the corrective work within the 14 calendar days or within such extended time as may have been allowed, the Contractor shall be liable and shall pay to the Village the amount shown in the Schedule of Deductions for Each Day of Overrun in Contract Time, not as a penalty but as liquidated damages, for each day of overrun beyond the 14 calendar days or such extended time as may have been allowed.

MAINTENANCE OF ROADWAYS

Effective: September 30, 1985

Revised: November 1, 1996

Beginning on the date that work begins on this project, the Contractor shall assume responsibility for normal maintenance of all existing roadways within the limits of the improvement. This normal maintenance shall include all repair work deemed necessary

**MICHIGAN AVENUE IMPROVEMENT PROJECT
(CENTRAL TO KENILWORTH)
VILLAGE OF VILLA PARK**

by the Engineer, but shall not include snow removal operations. Traffic control and protection for maintenance of roadways will be provided by the Contractor as required by the Engineer.

If items of work have not been provided in the contract, or otherwise specified for payment, such items, including the accompanying traffic control and protection required by the Engineer, will be paid for in accordance with Article 109.04 of the "Standard Specifications".

KEEPING ROADS OPEN TO TRAFFIC

All roads shall remain open to traffic unless otherwise shown on the contract plans. When necessary to close one lane because of construction, the Contractor shall maintain one-way traffic during construction hours with the use of signs and flaggers as shown on the Traffic Control Standards. Two lanes of traffic will be maintained during nights and weekends when no construction activities are being carried on.

TEST STRIPS

Test strips shall be in accordance with Section 406 and Section 1030 of the Standard Specifications, except as modified herein.

Remove all references to the payment of test strips and the payment of the HMA mixture in test strips from the Standard Specifications.

Test strips and the HMA mixture in test strips, if required, will not be measured for payment but shall be included in the unit bid prices of hot-mix asphalt binder courses and hot-mix asphalt surface courses.

RESPONSIBILITY FOR VANDALISM

The Contractor shall be responsible for the protection of all equipment and materials. Any equipment or materials which are stolen, missing, lost, damaged or vandalized shall be the Contractor's responsibility to replace or repair as needed at no additional cost to the contract.

The Contractor shall be responsible for the defacement of any concrete pours before they have set up. Concrete pavement, sidewalk, driveway, or curbing that has been defaced, in the opinion of the Engineer, shall be removed and replaced by the Contractor at Contractor's expense.

**MICHIGAN AVENUE IMPROVEMENT PROJECT
(CENTRAL TO KENILWORTH)
VILLAGE OF VILLA PARK**

USE OF FIRE HYDRANTS

Revise Article 107.18, Use of Fire Hydrants, of the Standard Specifications to read:

“107.18 Use of Fire Hydrants. If Contractor requires water for the completion of construction operations, and desires to obtain water from the Village, the Contractor shall make written application to the Village. If such application is approved by the Village, the Contractor shall obtain water from the fire hydrant located at 100 West Home Avenue, adjacent to the Village of Villa Park Fleet Maintenance Garage. Contractor’s use of said hydrant and methods of obtaining water shall be in compliance with all applicable ordinances, rules, and regulations concerning such use. Contractor shall furnish all labor and equipment necessary to make a connection to said hydrant, and to obtain and transport water.

Prior to obtaining water, Contractor shall make written application to the Village for temporary use of a hydrant meter. If the application for temporary use of a hydrant meter is approved, the Contractor shall provide a deposit of three-thousand dollars (\$3,000.00) to the Village for the temporary use of said hydrant meter, which deposit will be held by the Village until such time that the meter is returned to the Village by the Contractor in satisfactory condition. Contractor shall use said hydrant meter when obtaining water, and shall comply with all conditions for the use of said meter. Contractor shall return the hydrant meter to the Village within 24 hours of project completion and within 24 hours of any request by the Village that the hydrant meter be returned.

If Contractor makes application for temporary use of a hydrant meter and the application is not approved, Contractor shall make record of the quantity of water obtained, along with the date and time obtained, and shall report such information after each use to the Village of Villa Park Public Works Department, 11 West Home Avenue. If such use takes place outside of the normal working hours of the Public Works Department, Contractor shall report such information immediately upon the commencement of normal working hours.

Contractor shall not use, operate or obtain water from any hydrants other than the hydrant prescribed. Contractor shall not obtain water from the Village for construction operations or activities not under contract with the Village.

If a water main break occurs and the Village determines that the water main break is a result of Contractor’s use of a hydrant, the Village may require the Contractor to repair the water main break in accordance with all applicable construction standards and requirements and at no cost to the contract, or may repair the water main break by other means and invoice the Contractor for reimbursement of the Village’s costs.

Water usage will be measured according to the Special Provisions WATER USAGE DEDUCTION and WATER USAGE CREDIT.”

**MICHIGAN AVENUE IMPROVEMENT PROJECT
(CENTRAL TO KENILWORTH)
VILLAGE OF VILLA PARK****TRENCH BACKFILL AND PIPE BEDDING**

All trench backfill and pipe bedding materials furnished under this contract shall be virgin, non-recycled materials.

All trench backfill shall be crushed aggregate of CA-6 gradation. The aggregate material shall be placed in lifts not exceeding 8 in. in depth, loose measurement, and compacted by mechanical means to the satisfaction of the Engineer.

All pipes installed under this contract shall be placed on a bedding of crushed aggregate of CA-7 or CA-11 gradation having a minimum thickness of 4 in. The bedding shall be placed to a minimum of 12 in. above the top of the pipe and any fittings.

The cost of furnishing and installing pipe bedding materials will not be paid for separately but shall be included in the cost of items to which this work pertains.

EXCAVATION AND BACKFILLING OF DRAINAGE AND UTILITY STRUCTURES

Excavation, bedding and backfilling of drainage and utility structures which are constructed, reconstructed, or adjusted as a part of this contract will not be paid for separately but shall be included in the cost of the items to which this work pertains.

ADJUSTING RINGS

All drainage and utility structures which are constructed, reconstructed, or adjusted as a part of this contract shall have adjusting rings installed between the topmost section of the structure and the casting.

Each structure shall be fitted with a minimum of one adjusting ring and a maximum of two adjusting rings. The topmost adjusting ring on each structure shall be rubber. The second adjusting ring on each structure, if needed, shall be precast concrete with steel reinforcement. The total height of all adjusting rings on a single structure shall be a minimum of 2 in. and a maximum of 12 in.

The mating faces of adjusting rings shall be smooth, parallel, and free of cracks, chips, spalling, or casting irregularities. Rubber mastic shall be installed between each joint.

Adjusting rings will not be paid for separately but shall be included in the cost of the items to which this work pertains.

**MICHIGAN AVENUE IMPROVEMENT PROJECT
(CENTRAL TO KENILWORTH)
VILLAGE OF VILLA PARK**

SALVAGE AND DISPOSAL OF EXISTING MATERIALS

Existing manufactured materials which are removed and are not to be reused, including, but not limited to, frames, grates, lids, castings, sign posts, sign panels, fire hydrants, valves, stops, and fittings, shall remain the property of the Village unless the Engineer waives this requirement as specified herein.

Existing manufactured materials which are removed and are not to be reused will be inspected by the Engineer. Materials which are determined by the Engineer to be in satisfactory condition shall remain the property of the Village and shall be delivered by the Contractor to the Village of Villa Park Public Works Department yard located at 51 South Ardmore Avenue in Villa Park. Delivery shall be made during the normal working hours of the Village of Villa Park Public Works Department and the Contractor shall coordinate the day, time, and other details of delivery with the Village.

Materials which are determined by the Engineer to be in unsatisfactory condition shall become the property of the Contractor and shall be removed from the site by the end of the workday and properly disposed of by the Contractor.

The delivery or disposal of materials will not be paid for separately but shall be included in the cost of all items that include removal of existing materials.

FRAMES, GRATES AND LIDS

Frames, grates, lids and all other castings furnished under this contract shall be in accordance with Section 602 and Section 604 of the Standard Specifications, except as modified herein.

Castings shall conform to ASTM A48 Class 30. Castings shall be free of cracks, holes, swells, cold shuts, and patches. Castings shall not be coated or painted.

Frames, grates, lids and other castings shall be furnished in accordance with the following:

Type 1 frames and closed lids shall be Neenah R-1713 self-sealing or approved equal.

Type 1 frames and open lids shall be Neenah R-1713 or approved equal.

Type 11 frames and grates located in barrier curb and gutter shall be Neenah R-3281-A with curb box or approved equal.

Type 11 frames and grates located in depressed curb and gutter shall be Neenah R-3281-A with depressed curb grate or approved equal.

**MICHIGAN AVENUE IMPROVEMENT PROJECT
(CENTRAL TO KENILWORTH)
VILLAGE OF VILLA PARK**

All other castings not specified above shall be as shown on the plans or as determined by the Engineer. If any of the castings specified are not compatible in the field due to frame height or other constraints, the Contractor shall propose an alternate casting to the Engineer for approval and shall furnish the alternate casting if approved.

Frames, grates, lids and other castings located within curb ramps or crosswalks shall be substituted with ADA compliant castings.

All closed lid castings furnished under this contract shall be self-sealing, gasketed, watertight, and shall have machined bearing surfaces and concealed pick holes. The top surface of all lids and grates shall be embossed with the words "VILLAGE OF VILLA PARK". The top surface of closed lids shall also be embossed with the word "SANITARY", "STORM", or "WATER" as appropriate.

Enviro-curb logos on curb boxes for Type 11 or 11V frames and grates shall have the words "DUMP NO WASTE" and "DRAINS TO RIVER" or "DRAINS TO WATERWAY" cast into the top of all curb boxes.

This work will not be paid for separately but shall be included in the cost of all pay items that include the furnishing of frames, grates, lids, or other castings.

DATE OF MANUFACTURE

All manufactured materials furnished under this contract, including, but not limited to, frames, grates, lids, castings, fire hydrants, pipe, drainage and utility structures, valves, stops, and fittings, shall have been manufactured no earlier than January 1 of the calendar year in which they are to be installed.

IRON AND STEEL MATERIALS

All iron and steel materials furnished under this contract shall be domestically manufactured or produced and fabricated in accordance with Article 106.01 of the Standard Specifications.

PROTECTION OF EXISTING DRAINAGE FACILITIES DURING CONSTRUCTION

Unless otherwise noted in the contract plans, the existing drainage facilities shall remain in use during the period of construction.

Locations of existing drainage structures and sewers, if shown on the contract plans, are approximate. Prior to commencement of work, the Contractor, at his/her own

**MICHIGAN AVENUE IMPROVEMENT PROJECT
(CENTRAL TO KENILWORTH)
VILLAGE OF VILLA PARK**

expense, shall determine the exact location of existing structures which are within the proposed construction site.

All drainage structures are to be kept free from any debris resulting from construction operations. All work and materials necessary to prevent accumulation of debris in the drainage structure resulting from construction operations shall be removed at the Contractor's own expense, and no extra compensation will be allowed.

Unless reconstruction or adjustment of an existing manhole, catch basin, or inlet is called for in the contract plans or ordered by the Engineer, the proposed work shall meet the existing elevations of these structures. Should reconstruction or adjustment of a drainage structure be required by the Engineer in the field, the necessary work and payment shall be done in accordance with Section 602 and Article 104.02 respectively, of the Standard Specifications.

Existing frames and grates are to remain unless otherwise noted in the contract plans or as determined by the Engineer. Frames and grates that are missing or damaged prior to construction shall be replaced. The type of replacements frame or grate shall be determined by the Engineer, and replacement and payment for same shall be in accordance with Section 604 and Article 104.02 respectively, of the Standard Specifications unless otherwise noted in the plans or special provisions.

DROP HAMMERS

The use of drop hammers or similar equipment will not be permitted.

AVAILABLE REPORTS

The following reports are available for Bidders' reference upon request:

LPC-663

Geotechnical Report with Pavement Cores

Those seeking these reports should request access from:

Villa Park Public Works Department Website

<http://www.invillapark.com/196/Public-Works-Department>

**MICHIGAN AVENUE IMPROVEMENT PROJECT
(CENTRAL TO KENILWORTH)
VILLAGE OF VILLA PARK**

STATUS OF UTILITIES (D-1)

Utility companies and/or municipal owners located within the construction limits of this project have provided the following information regarding their facilities and the proposed improvements. The tables below contain a description of specific conflicts to be resolved and/or facilities which will require some action on the part of the Department's contractor to proceed with work. Each table entry includes an identification of the action necessary and, if applicable, the estimated duration required for the resolution.

UTILITIES TO BE ADJUSTED

Conflicts noted below have been identified by following the suggested staging plan included in the contract. The company has been notified of all conflicts and will be required to obtain the necessary permits to complete their work; in some instances, resolution will be a function of the construction staging. The responsible agency must relocate, or complete new installations as noted below; this work has been deemed necessary to be complete for the Department's contractor to then work in the stage under which the item has been listed.

Pre-Stage

STAGE / LOCATION	TYPE	DESCRIPTION	RESPONSIBLE AGENCY	DURATION OF TIME
Length of project	Gas	Gas Services	Nicor	Gas services adjusted and located. Contractor to contact Nicor when excavating around 2" Gas main and services to avoid conflicts.

The following contact information is what was used during the preparation of the plans as provided by the Agency/Company responsible for resolution of the conflict.

Agency/Company Responsible to Resolve Conflict	Name of contact	Phone	E-mail address
Nicor SC14920	Bruce Koppang	630.388.3046	gasmaps @aglresources.com

**MICHIGAN AVENUE IMPROVEMENT PROJECT
(CENTRAL TO KENILWORTH)
VILLAGE OF VILLA PARK**

UTILITIES TO BE WATCHED AND PROTECTED

The areas of concern noted below have been identified by following the suggested staging plan included for the contract. The information provided is not a comprehensive list of all remaining utilities, but those which during coordination were identified as ones which might require the Department's contractor to take into consideration when making the determination of the means and methods that would be required to construct the proposed improvement. In some instances, the contractor will be responsible to notify the owner in advance of the work to take place so necessary staffing on the owner's part can be secured.

Pre-Stage

STAGE / LOCATION	TYPE	DESCRIPTION	OWNER
Crossing at 15+70 Crossing at 17+60	Telephone	Aerial Cable	AT&T (on ComEd Poles)
Crossing at 15+70 Crossing at 17+60	Electrical	Aerial Electric Cable	ComEd
Crossing at 15+70 Crossing at 17+60	Cable	Aerial Cable	Comcast (on ComEd Poles)
West Parkway Project Length	Gas	2" Underground Gas Main	Nicor

The following contact information is what was used during the preparation of the plans as provided by the owner of the facility.

Agency/Company Responsible to Resolve Conflict	Name of contact	Phone	E-mail address
AT&T	Donna Szpytek	630.573.5530	ds2674@att.com
Comcast	Martha Gieras	630.600-6352	Martha_Gieras@cable.comcast.com
ComEd	Eric Jostas	630.437.2927	Eric.Jostas@ComEd.com
Nicor	Bruce Koppang	630.388.3046	gasmaps@agresources.com

The above represents the best information available to the Department and is included for the convenience of the bidder. The days required for conflict resolution should be

**MICHIGAN AVENUE IMPROVEMENT PROJECT
(CENTRAL TO KENILWORTH)
VILLAGE OF VILLA PARK**

considered in the bid as this information has also been factored into the timeline identified for the project when setting the completion date. The applicable portions of the Standard Specifications for Road and Bridge Construction shall apply.

Estimated duration of time provided above for the first conflicts identified will begin on the date of the executed contract regardless of the status of the utility relocations. The responsible agencies will be working toward resolving subsequent conflicts in conjunction with contractor activities in the number of days noted.

The estimated relocation duration must be part of the progress schedule submitted by the contractor. A utility kickoff meeting will be scheduled between the Department, the Department's contractor and the utility companies when necessary. The Department's contractor is responsible for contacting J.U.L.I.E. prior to all excavation work.

MICHIGAN AVENUE IMPROVEMENT PROJECT
(CENTRAL TO KENILWORTH)
VILLAGE OF VILLA PARK

PAY ITEM SPECIAL PROVISIONS

PAY ITEM #2 – STUMP REMOVAL

Description. This work shall consist of the cutting, grubbing, removal and disposal of stumps in accordance with the applicable portions of Section 201 of the Standard Specifications, and specified as herein at the locations shown on the plans and as directed by the Engineer.

The remaining portion of a tree that has been cut off at or near ground level and the remaining portion of a tree where a substantial portion of the tree trunk remains but almost all of the tree limbs have been removed. Tree stumps will not be considered as trees for the purpose of measurement and removal. Tree stumps removed during the performance of the work for tree removal will not be measured and paid for separately.

Method of Measurement. This work will be measured for payment per unit of diameter where one unit is equal to 1 inch at the elevation where the tree has been cut off or 4.5 ft. above the highest ground level at the base of the tree stump, whichever is lower.

Basis of Payment. This work will be paid for at the contract unit price per unit diameter for STUMP REMOVAL.

PAY ITEM #3 – TREE PROTECTION FENCING

Description. This work shall consist of installation, maintenance and removal of tree protection fencing. This work shall be in accordance with Section 201 of the Standard Specifications, except as modified herein.

Method of Measurement. This work will be measured for payment as each per tree.

Basis of Payment. This work will be paid for at the contract unit price per each for TREE PROTECTION FENCING.

PAY ITEM #4 – TREE ROOT PRUNING

Description. This work shall consist of performing tree root pruning. This work shall be in accordance with Section 201 of the Standard Specifications, except as modified herein.

Fertilizer nutrients and supplemental watering will not be paid for separately, but shall be included in the cost of TREE ROOT PRUNING.

**MICHIGAN AVENUE IMPROVEMENT PROJECT
(CENTRAL TO KENILWORTH)
VILLAGE OF VILLA PARK**

Method of Measurement. This work will be measured for payment as each per tree.

Basis of Payment. This work will be paid for at the contract unit price per each for TREE ROOT PRUNING.

PAY ITEM #5-6 – TREE PRUNING

Description. This work shall consist of performing tree pruning. This work shall be in accordance with Section 201 of the Standard Specifications and the current ANSI A300 (Part 1) – Pruning standard, except as modified herein.

All tree pruning shall be performed by a professional arborist.

Method of Measurement. This work will be measured for payment as each per tree.

Basis of Payment. This work will be paid for at the contract unit price per each for TREE PRUNING of the size specified.

PAY ITEM #7 – TREES

Description. This work shall consist of furnishing and installing trees in accordance with Section 253 of the Standard Specifications and ANSIZ133.1. The VILLAGE will designate the location and type of tree to be installed from the following list of permitted parkway trees:

Sugar maple Norway maple	Accolade elm	Hackberry tree
Scarlet (red) maple	Triumph elm	Tulip tree
Crimson King maple	Gingko	Beech tree
American linden	Kentucky Coffee	Sweet Gum tree
European linden	Pin oak	Crab tree
Busiman elm	Red oak	River birch
Liberty elm	Swamp white oak	Skyline locust

All trees shall be 2" caliper, balled, bur lapped, transported, planted, mulched and receive one watering. Trees will be replaced only on a 1:1 basis unless otherwise

**MICHIGAN AVENUE IMPROVEMENT PROJECT
(CENTRAL TO KENILWORTH)
VILLAGE OF VILLA PARK**

directed by the ENGINEER. Trees shall be free from infectious disease or insect infestation at the time of planting. Final locations of trees will be determined in the field by the ENGINEER. Trees shall not be planted in locations that will interfere with existing or proposed utilities, and aerial utility lines.

Codes and Reference Standards. All materials shall conform to the standards adopted by the American Association of Nurserymen.

Scheduling. Fall planting shall be performed from the time the plant becomes dormant until the ground cannot be satisfactorily worked.

Shredded Hardwood Bark Mulch. Shredded hardwood bark mulch shall be free of harmful chemicals, diseases, and insects. Mulch shall have a minimum 1 /8 inch dimension and a maximum length of 2-1/2".

Surface Conditions. Apply a total non-plant selective herbicide to the outline of all mass planting beds. Follow manufactures instructions for use and applications. Herbicide to be applied by a licensed applicator. Sod stripping shall be included. After herbicide manufacture recommendations for sufficient time to perform removes existing turf and vegetation debris. Dispose of offsite.

Excavation of Plant Holes.

Shape: The sides of all plant holes shall be sloped and the bottoms horizontal.

Size: Tree excavations shall be the ball depth by the ball diameter plus 24 inches. Shrub excavations shall be dug to the depth of the root ball and the ball diameter plus 18 inches. Ground cover shall be a minimum diameter and depth of the container plus 8 inches.

All excess excavated material shall be removed from the site, become property of the CONTRACTOR, or dumped at a legal offsite location.

Removal and disposal of any roots encountered during excavation of the plant hole shall be considered included in the cost of this item.

Planting. Remove all rocks and debris over 1" in diameter from top 3" of planting beds. Remove top two inches of exiting soil from entire surface of mass planting beds. Apply a 3" layer of Mushroom compost over entire surface of mass planting beds. Prepared backfill shall consist of a mixture of top soil and peat moss at a ratio of 1 cubic yard soil, 3 cubic feet of peat moss. Prepared backfill soil shall be in a loose friable condition at the time of planting. All plants shall be placed in a plumb position and set at the same depth and orientation as they grew in the nursery field. Tamping or watering shall accompany the backfilling operation to eliminate air pockets. Trees shall be planted on the center line of the parkway, unless otherwise directed by the VILLAGE.

**MICHIGAN AVENUE IMPROVEMENT PROJECT
(CENTRAL TO KENILWORTH)
VILLAGE OF VILLA PARK**

Balled and Burlapped Plants. After the plant is placed in the hole, all cords and burlap shall be cut away from the trunk and the burlap and any wire baskets removed from the top of the ball.

Watering. Within two hours after the tree has been placed, tree shall be substantially watered.

Basis of Payment. This work shall be paid for at the contract unit price per EACH for TREES, regardless of the tree species selected by the Village.

PAY ITEM #12 – PARKWAY RESTORATION

Description. This work shall be done in accordance with Sections 211 and 252 of the Standard Specifications and the Details provided in the Plans, except where modified herein.

The purpose of this work is to restore the areas disturbed by construction and/or to provide proper drainage in the parkways.

This work shall include restoring disturbed areas within the construction limits, removing excess backfill material, furnishing and placing topsoil in accordance with Section 211, compacting and grading to maintain positive slope, and sodding the areas in accordance with Section 252. Care should be taken to insure proper compaction as the Contractor will be responsible for repair of any areas where settlement occurs.”

Sod watering and supplemental watering are included in PARKWAY RESTORATION shall be done in accordance with Article 252.08 and 252.09.

211.02 Materials. Add the following to the end of the Article:

“Topsoil shall be a loamy mixture of black dirt having at least 90 percent passing a No. 10 sieve, and shall be free of large roots, brush, sticks, weeds, stones larger than 1/2-inch in diameter and any other litter. Topsoil, pH shall not be lower than 4.5 nor higher than 8.5 as determined in accordance with ASTM procedures for soil testing. Sod shall be salt tolerant.”

211.04 Placing Topsoil and Compost. Add the following to the end of the Article:

“The topsoil shall be spread to a smooth, compacted uniform thickness of not less than 4 inches.”

252.03 Ground Preparation. Add the following to the end of the Article:

**MICHIGAN AVENUE IMPROVEMENT PROJECT
(CENTRAL TO KENILWORTH)
VILLAGE OF VILLA PARK**

“The removal of any excess backfill material shall be included in the pay item for PARKWAY RESTORATION.

Fertilizer nutrients shall be applied in accordance with Section 252.03 of the Standard Specifications and shall be included in the pay item for PARKWAY RESTORATION.”

252.06 Placing Sod. Add the following to the end of the Article:

“The Contractor shall provide subsequent resodding until a satisfactory growth of grass is produced or if settlement occurs.”

Method of Measurement.

211.07 and 252.12 Method of Measurement. Delete the final paragraph of Article 252.12, Replace Article 211.07 and the first paragraph of 252.12 with the following:

“Method of Measurement. This work will be measured for payment in place, and the area computed in square yards. To be acceptable for final payment, the sod shall be growing in place for a minimum of 30 days in a live, healthy condition.”

Basis of Payment.

211.08 and 252.13 Basis of Payment. Delete the final paragraph of Article 252.13, Replace Article 211.08 and the first three paragraphs of 252.13 with the following:

“Basis of Payment. This work will be paid for at the contract unit price per square yard for PARKWAY RESTORATION.”

PAY ITEM #14 – INLET FILTERS

Description. This work shall consist of installing, maintaining and cleaning inlet filters as shown on the plans or as determined by the Engineer. This work shall be in accordance with Section 280 of the Standard Specifications, except as modified herein.

Inlet filters shall consist of metal frames with attached fabric bags. Contractor shall furnish inlet filters of appropriate sizes and shapes necessary to accommodate all different types of drainage structures encountered. The use of filter fabric without a frame will not be an acceptable material for inlet filters and will be rejected.

Contractor shall inspect and clean all inlet filters weekly, after every rainfall, and additionally as needed. Maintenance and cleaning of inlet filters will not be paid for separately but shall be included in the cost of this work.

**MICHIGAN AVENUE IMPROVEMENT PROJECT
(CENTRAL TO KENILWORTH)
VILLAGE OF VILLA PARK**

Method of Measurement. This work will be measured for payment as each individual inlet filter installed and the unit of measurement will be each. No measurement will be made of maintenance and cleaning efforts. If an inlet filter is installed on multiple structures the inlet filter will only be measured for payment once.

Basis of Payment. This work will be paid for at the contract unit price per each for INLET FILTERS.

PAY ITEM #15 – AGGREGATE SUBGRADE IMPROVEMENT

Add the following Section to the Standard Specifications:

“SECTION 303. AGGREGATE SUBGRADE IMPROVEMENT

303.01 Description. This work shall consist of constructing an aggregate subgrade improvement.

303.02 Materials. Materials shall be according to the following.

	Item	Article/Section
(a)	Coarse Aggregate	1004.07
(b)	Reclaimed Asphalt Pavement (RAP) (Notes 1, 2 and 3)	1031

Note 1. Crushed RAP, from either full depth or single lift removal, may be mechanically blended with aggregate gradation CS 01 but shall not exceed 40 percent by weight of the total product. The top size of the Coarse RAP shall be less than 4 in. (100 mm) and well graded.

Note 2. RAP having 100 percent passing the 1 1/2 in (37.5 mm) sieve and being well graded, may be used as capping aggregate in the top 3 in. (75 mm) when aggregate gradation CS 01 is used in lower lifts. When RAP is blended with any of the coarse aggregates, the blending shall be done with mechanically calibrated feeders. The final product shall not contain more than 40 percent by weight of RAP.

Note 3. The RAP used for aggregate subgrade improvement shall be according to the current Bureau of Materials and Physical Research Policy Memorandum, "Reclaimed Asphalt Pavement (RAP) for Aggregate Applications".

**MICHIGAN AVENUE IMPROVEMENT PROJECT
(CENTRAL TO KENILWORTH)
VILLAGE OF VILLA PARK**

303.03 Equipment. The vibratory machine shall be according to Article 1101.01, or as approved by the Engineer. The calibration for the mechanical feeders shall have an accuracy of ± 2.0 percent of the actual quantity of material delivered.

303.04 Soil Preparation. The stability of the soil shall be according to the Department's Subgrade Stability Manual for the aggregate thickness specified.

303.05 Placing Aggregate. The maximum nominal lift thickness of aggregate gradation CS 01 shall be 24 in. (600 mm).

303.07 Compaction. All aggregate lifts shall be compacted to the satisfaction of the Engineer. If the moisture content of the material is such that compaction cannot be obtained, sufficient water shall be added so that satisfactory compaction can be obtained.

303.08 Finishing and Maintenance of Aggregate Subgrade Improvement. The aggregate subgrade improvement shall be finished to the lines, grades, and cross sections shown on the plans, or as directed by the Engineer. The aggregate subgrade improvement shall be maintained in a smooth and compacted condition.

303.09 Method of Measurement. This work will be measured for payment according to Article 311.08.

303.10 Basis of Payment. This work will be paid for at the contract unit price per cubic yard for AGGREGATE SUBGRADE IMPROVEMENT.

Add the following to Section 1004 of the Standard Specifications

"1004.07 Coarse Aggregate for Aggregate Subgrade Improvement. The aggregate shall be according to Article 1004.01 and the following.

- (a) Description. The coarse aggregate shall be crushed gravel, crushed stone, or crushed concrete. The top 12 inches of the aggregate subgrade improvement shall be 3 inches of capping material and 9 inches of crushed gravel, crushed stone or crushed concrete. In applications where greater than 36 inches of subgrade material is required, rounded gravel, meeting the CS01 gradation, may be used beginning at a depth of 12 inches below the bottom of pavement.
- (b) Quality. The coarse aggregate shall consist of sound durable particles reasonably free of deleterious materials. Non-mechanically blended RAP may be allowed up to a maximum of 5.0 percent.
- (c) Gradation.

**MICHIGAN AVENUE IMPROVEMENT PROJECT
(CENTRAL TO KENILWORTH)
VILLAGE OF VILLA PARK**

- (1) The coarse aggregate gradation for total subgrade thicknesses of 12 in. (300 mm) or greater shall be CS 01.

COARSE AGGREGATE SUBGRADE GRADATIONS					
Grad No.	Sieve Size and Percent Passing				
	8"	6"	4"	2"	#4
CS 01	100	97 ± 3	90 ± 10	45 ± 25	20 ± 20

COARSE AGGREGATE SUBGRADE GRADATIONS (Metric)					
Grad No.	Sieve Size and Percent Passing				
	200 mm	150 mm	100 mm	50 mm	4.75 mm
CS 01	100	97 ± 3	90 ± 10	45 ± 25	20 ± 20

- (2) The 3 in. (75 mm) capping aggregate shall be gradation CA 6 or CA 10.

PAY ITEM #17 – BITUMINOUS MATERIALS (TACK COAT)

Description. This work shall consist of the preparation and application of bituminous tack coat on concrete or HMA bases prior to HMA placement. This work shall be in accordance with Section 406 of the Standard Specifications, except as modified herein.

Bituminous tack coat shall be placed at least one hour in advance of the placement of HMA, but no more than 48 hours in advance of the placement of HMA. If Contractor places tack coat more than 48 hours in advance of the placement of HMA, the tack coat

**MICHIGAN AVENUE IMPROVEMENT PROJECT
(CENTRAL TO KENILWORTH)
VILLAGE OF VILLA PARK**

will not be measured for payment, and Contractor will place tack coat again in accordance with this provision. Tack coat shall not be placed on weekends or on holidays unless permitted by the Engineer. Tack coat shall not be placed before weekends or holidays when placement of HMA is not expected to take place until after the weekend or holiday, unless permitted by the Engineer.

Basis of Payment. This work will be paid for at the contract unit price per pound for BITUMINOUS MATERIALS (TACK COAT).

PAY ITEM #21 – HOT-MIX ASPHALT DRIVEWAY PAVEMENT

Description. This work shall be performed in accordance with Articles 406.02, 406.03, 406.05, 406.06, 406.07, and 406.12 of the Standard Specifications, and the detail shown on the Plans, except as modified herein. This work shall consist of placing HMA Binder Course, IL-19.0 N50 and HMA Surface Course, Mix "D" N50, to the minimum thickness below or to match the existing HMA thickness, whichever is greater.

HMA Driveway Pavement 4" (Private Entrance)
HMA Surface Course, Mix "D", N50; 1 1/2"
HMA Binder Course, IL-19.0, N50; 2 1/2"
Aggregate Base Course, Type B; 6"

Aggregate base course is included and is not paid for separately.

Method of Measurement. This work shall be measured for payment in place and the area computed in square yards.

Basis of Payment. This work will be paid for at the contract unit price per square yard for HOT-MIX ASPHALT DRIVEWAY PAVEMENT, of the depth specified.

PAY ITEM #22 – PORTLAND CEMENT CONCRETE DRIVEWAY PAVEMENT

Description. This work shall be performed in accordance with Section 423 of the Standard Specifications, and the detail shown on the Plans, except as modified herein.

PCC Driveway Pavement 6" (Private Entrance)
PCC Driveway Pavement; 6"
Aggregate Base Course, Type B; 4"

Aggregate base course is included and is not paid for separately.

Method of Measurement. This work shall be measured for payment in place and the area computed in square yards.

**MICHIGAN AVENUE IMPROVEMENT PROJECT
(CENTRAL TO KENILWORTH)
VILLAGE OF VILLA PARK**

Basis of Payment. This work will be paid for at the contract unit price per square yard for PORTLAND CEMENT CONCRETE DRIVEWAY PAVEMENT, of the depth specified.

PAY ITEM #23 – PORTLAND CEMENT CONCRETE SIDEWALK

Description. This work shall be performed in accordance with Section 424 of the Standard Specifications, and the detail shown on the Plans, except as modified herein.

PCC Sidewalk 5"
PCC Sidewalk; 5" (6" through driveways)
Aggregate Base Course, Type B; 4"

Aggregate base course is included and is not paid for separately.

Method of Measurement. This work shall be measured for payment in place and the area computed in square feet.

Basis of Payment. This work will be paid for at the contract unit price per square yard for PORTLAND CEMENT CONCRETE SIDEWALK, of the depth specified.

PAY ITEM #24 – DETECTABLE WARNINGS

Description. This work shall consist of installing detectable warnings. This work shall be in accordance with Section 424 of the Standard Specifications, except as modified herein.

Detectable warnings shall be installed at curb ramps and other locations where pedestrians are required to cross a hazardous vehicular way. Detectable warnings shall also be installed at alleys and commercial entrances where permanent traffic control devices are present.

Materials. Detectable warnings shall be pre-cast tiles. Installation shall be cast-in-place. Surface mounted applications will not be permitted. Detectable warnings shall be red in color. Detectable warning tiles shall be either rectangular or radial in shape as shown on the plans or as determined by the Engineer. The product or products to be used for detectable warnings shall be approved by the Engineer prior to use.

Construction. Installation shall be according to the manufacturer's specifications and as determined by the Engineer.

Where a curb ramp is 5 ft. in width or less and a rectangular detectable warning tile is to be used, the installation shall consist of a single detectable warning tile. If a pre-cast

**MICHIGAN AVENUE IMPROVEMENT PROJECT
(CENTRAL TO KENILWORTH)
VILLAGE OF VILLA PARK**

detectable warning tile is not manufactured in the width of the curb ramp, a larger detectable warning tile shall be furnished and shall be cut to the width of the curb ramp.

Installation of multiple detectable warning tiles at a single curb ramp will only be permitted where a curb ramp exceeds 5 ft. in width or where radial detectable warning tiles are to be used. Where multiple detectable warning tiles are permitted at a single curb ramp, they shall be mechanically joined prior to installation.

Method of Measurement. Detectable warnings will be measured for payment in place and the area computed in square feet.

Basis of Payment. This work will be paid for at the contract unit price per square foot for DETECTABLE WARNINGS.

PAY ITEM #25 – PAVEMENT REMOVAL

Description. This work shall be done in accordance with Section 440 of the Standard Specifications except as modified herein.

440.07 (c) Adjustment of quantities. Revise section to read:

“The quantity of pavement removal shall not be adjusted. Pavement removal includes any pavement or subgrade to a depth of 10 inches. If pavement thickness greater 10 inches is encountered the remaining pavement removal shall be paid for as EARTH EXCAVATION.”

PAY ITEM #26 – DRIVEWAY PAVEMENT REMOVAL

Description. This work shall be done in accordance with Section 440 of the Standard Specifications except as modified herein.

440.07 (c) Adjustment of quantities. Revise section to read:

“This work shall include all pavement removal and excavation required to reach the subgrade. A minimum excavation depth of 10 inches shall include the excavation for the proposed aggregate base.”

PAY ITEM #28 – SIDEWALK REMOVAL

Description. This work shall be done in accordance with Section 440 of the Standard Specifications except as modified herein.

**MICHIGAN AVENUE IMPROVEMENT PROJECT
(CENTRAL TO KENILWORTH)
VILLAGE OF VILLA PARK**

The removal and disposal of any additional material required to establish the proposed sidewalk subgrade elevation shall be included.

Method of Measurement. Sidewalk removal will be measured for payment in place and the area computed in square feet.

Basis of Payment. This work will be paid for at the contract unit price per square foot for SIDEWALK REMOVAL.

PAY ITEM #29-32 – STORM SEWERS, RUBBER GASKET

Description. This work shall be done in accordance with Section 550 and Section 551 of the Standard Specifications except as modified herein.

Basis of Payment. 550.10 Basis of Payment. Revise the first paragraph of this Article to read:

“550.10 Basis of Payment. This work will be paid for at the contract unit price per foot for STORM SEWERS, RUBBER GASKET, of the class, type, and diameter specified, which price shall also include connections to existing storm sewer structures and existing storm sewers. If any storm sewer laterals are found during construction and are not identified on the plans, they shall be connected to the proposed storm sewer system and included in the cost of the storm sewer construction.”

551.06 Basis of Payment. Revise the paragraph of this Article to Read:

“Storm sewer removal will not be paid for if proposed storm sewer is being installed in the same trench.”

PAY ITEM #33 – STORM SEWER RESTRICTOR

Description. This work shall consist of furnishing and installing the restrictor pipe mortared in the proposed outlet, complete with capped perforated PVC pipe cross as shown in the details on the plans. This work shall be done in accordance with Section 550 of the Standard Specifications except as modified herein.

Basis of Payment. This work will be paid for at the contract unit price per each for STORM SEWER RESTRICTOR of the size specified.

**MICHIGAN AVENUE IMPROVEMENT PROJECT
(CENTRAL TO KENILWORTH)
VILLAGE OF VILLA PARK**

PAY ITEM #34 – STORM SEWER (WATER MAIN REQUIREMENTS)

Description. This work shall be done in accordance with Section 550 and Section 551 of the Standard Specifications except as modified herein.

Materials. 550.02 Materials. Revise this Article to read:

“550.02 Materials. The storm sewer pipe shall be water main quality pipe meeting the requirements of sections 40 and 41 – 2.01 of the “Standard Specifications for Water and Sewer Main Construction in Illinois”. PVC (SDR 26) pipe shall be used in accordance with ASTM D-2241, or PVC DR-18 in accordance with AWWA C900 or C905, with joints conforming to ASTM D-3139 and flexible elastomeric gaskets meeting ASTM F-477 criteria.”

Basis of Payment. 550.10 Basis of Payment. Revise the first paragraph of this Article to read:

“550.10 Basis of Payment. This work will be paid for at the contract unit price per foot for **STORM SEWER (WATER MAIN REQUIREMENTS)**, of the diameter specified, which price shall also include connections to existing storm sewer structures and existing storm sewers. If any storm sewer laterals are found during construction and are not identified on the plans, they shall be connected to the proposed storm sewer system and included in the cost of the storm sewer construction”

551.06 Basis of Payment. Revise the paragraph of this Article to Read:

“Storm sewer removal will not be paid for if proposed storm sewer is being installed in the same trench.”

PAY ITEM #37-40 – CATCH BASINS, MANHOLES, AND INLETS

Description. The cost of making any sewer connections to existing drainage structures or pipe shall be included in the cost of the new structure. Any additional storm sewer pipe required to make the connection shall be of the same size and material type as the existing storm sewer and shall be included in the cost of the structure.

PAY ITEM #51 – WATER VALVES

Description. This work shall consist of constructing water valves. This work shall be in accordance with applicable portions of Section 561 of the Standard Specifications and with the Standard Specifications for Water and Sewer Construction in Illinois, except as modified herein.

**MICHIGAN AVENUE IMPROVEMENT PROJECT
(CENTRAL TO KENILWORTH)
VILLAGE OF VILLA PARK**

Materials. Water valves shall be AMERICAN Flow Control Series 2500 Ductile Iron Resilient Wedge Gate Valves conforming to ANSI/AWWA C515, with mechanical joint end connections, of the diameter specified, or approved equal. All exterior valve body bolting shall be Type 304 stainless steel.

Water main pipe shall be ductile iron pipe conforming to ANSI/AWWA C151/A21.51, Class 52 standard thickness, with push-on joints conforming to AWWA C111.

Water main couplings shall be Krausz Hymax Grip coupling restraints of the diameter required, or approved equal.

Mechanical joint restraints shall be EBAA Iron, Inc., MEGALUG Mechanical Joint Restraints for Ductile Iron Pipe, or approved equal.

All bolts, nuts, washers, and other hardware to be installed below grade shall be Type 304 stainless steel.

Construction. Water valves shall be installed in a pre-cast concrete valve vault unless otherwise specified. The valve shall be placed on a solid concrete block resting on the bottom of the valve vault. The valve shall be placed so that the operating nut is centered under the opening of the valve vault.

Where a new water valve is to be installed on an existing water main, the existing water main shall be cut by an approved method and a section of existing water main of sufficient length shall be removed. The valve shall be joined on both ends to sections of new water main pipe of the proper length with mechanical joint restraints. The valve and pipe assembly shall be positioned in place between the two cut ends of the existing water main and the ends of the existing water main shall be joined to the valve assembly with water main couplings of the proper size. The labor, equipment and materials which are necessary to construct a new water valve on an existing water main will not be paid for separately but shall be included in the cost of this work.

Where an existing water valve is to be removed and replaced with a new water valve in substantially the same location, removal of the existing water valve will not be paid for separately but shall be included in the cost of this work.

Excavation, bedding, and backfilling needed for the installation of water valves will not be paid for separately but shall be included in the cost of this work.

Basis of Payment. This work will be paid for at the contract unit price per each for WATER VALVES, of the diameter specified.

**MICHIGAN AVENUE IMPROVEMENT PROJECT
(CENTRAL TO KENILWORTH)
VILLAGE OF VILLA PARK**

PAY ITEM #53 – FIRE HYDRANTS TO BE REMOVED

Description. This work shall consist of removing fire hydrants in locations where new fire hydrants are not to be installed. This work shall be in accordance with Section 564 of the Standard Specifications and with the Standard Specifications for Water and Sewer Construction in Illinois, except as modified herein.

Where an existing fire hydrant is to be removed and replaced with a new fire hydrant in substantially the same location, removal of the existing fire hydrant will not be paid for separately but shall be included in the cost of the fire hydrant installation.

Materials. Water main pipe shall be ductile iron pipe conforming to ANSI/AWWA C151/A21.51, Class 52 standard thickness.

Water main couplings shall be Krausz Hymax Grip coupling restraints of the diameter required, or approved equal.

All bolts, nuts, washers, and other hardware to be installed below grade shall be Type 304 stainless steel.

Construction. The existing fire hydrant, auxiliary valve, valve box, hydrant lead, tee, and a portion of the adjoining water main shall be excavated and exposed. The existing water main shall be cut on both sides of the tee by an approved method and a section of existing water main shall be removed along with the tee, hydrant lead, valve box, auxiliary valve and fire hydrant. A section of new water main pipe of the proper length shall be positioned in place between the two cut ends of the existing water main and the ends of the existing water main shall be joined to the new section of water main pipe with water main couplings of the proper size.

The excavation shall be backfilled with crushed aggregate of CA-6 gradation and mechanically compacted in lifts not exceeding 12 in.

Excavation and backfilling will not be paid for separately, but shall be included in the cost of this work.

Fire hydrants which are removed and are selected by the Engineer to be salvaged shall remain the property of the Village and shall be delivered by the Contractor to the Village of Villa Park Public Works Department yard located at 51 South Ardmore Avenue in Villa Park. Delivery shall be made during the normal working hours of the Village of Villa Park Public Works Department and the Contractor shall coordinate the day, time and other details of delivery with the Village. Fire hydrants which are not selected by the Engineer to be salvaged shall become the property of the Contractor and shall be removed from the site by the end of the workday and properly disposed of by the Contractor. The delivery or disposal of fire hydrants will not be paid for separately but shall be included in the cost of this work.

**MICHIGAN AVENUE IMPROVEMENT PROJECT
(CENTRAL TO KENILWORTH)
VILLAGE OF VILLA PARK**

Basis of Payment. This work will be paid for at the contract unit price per each for FIRE HYDRANTS TO BE REMOVED.

PAY ITEM #54 – FIRE HYDRANT WITH AUXILIARY VALVE AND VALVE BOX

Description. This work shall consist of constructing fire hydrants with auxiliary valves and valve boxes. This work shall be in accordance with Section 564 of the Standard Specifications and with the Standard Specifications for Water and Sewer Construction in Illinois, except as modified herein.

Materials. Fire hydrants shall be AMERICAN Flow Control 5-¼" Waterous Pacer Fire Hydrant Model WB67-250, conforming to ANSI/AWWA C502, 6' - 0" bury depth, with all stainless steel trim, above-ground breakable flanges, and auxiliary resilient wedge gate valve and valve box. Fire hydrants shall be fitted with DDP-arrangement nozzle sections with one 4-½ in. pumper nozzle and two 2-½ in. hose nozzles with National Standard threads and a National Standard operating nut.

Fire hydrants shall be factory painted red, prime coated with an epoxy, and finish coated with a two-part polyurethane top coat. Fire hydrants that are not factory painted red will be considered unacceptable and will be rejected.

Fire hydrants which are to be constructed on existing water mains where a 6' - 0" bury depth is incompatible with the depth of the existing water main shall be substituted with a fire hydrant of a different bury depth as approved by the Engineer.

Auxiliary valves shall be AMERICAN Flow Control Series 2500 Ductile Iron Resilient Wedge Gate Valves conforming to ANSI/AWWA C515, with mechanical joint end connections, 6 in. diameter. All exterior valve body bolting shall be Type 304 stainless steel.

Valve boxes shall have a cover embossed with the word "WATER".

Hydrant lead pipe shall be ductile iron pipe conforming to ANSI/AWWA C151/A21.51, Class 52 standard thickness, with push-on joints conforming to AWWA C111, 6 in. diameter.

Water main couplings shall be Krausz Hymax Grip coupling restraints of the diameter required, or approved equal.

Mechanical joint restraints shall be EBAA Iron, Inc., MEGALUG Mechanical Joint Restraints for Ductile Iron Pipe, or approved equal.

Valve box stabilizer grips shall be by BLR Enterprises, Inc., or approved equal.

**MICHIGAN AVENUE IMPROVEMENT PROJECT
(CENTRAL TO KENILWORTH)
VILLAGE OF VILLA PARK**

All hardware and fasteners to be installed below grade shall be stainless steel. Bolts and threaded rods shall be Type 304 stainless steel and nuts and washers shall be Type 300 stainless steel.

Fire hydrant barrel extensions, if permitted, shall be AMERICAN Flow Control Waterous Series and shall be a maximum of 18 in.

Construction. Where an existing fire hydrant is to be removed and replaced with a new fire hydrant with auxiliary valve and valve box in substantially the same location, the existing fire hydrant, auxiliary valve, valve box, hydrant lead pipe, and tee shall be excavated and exposed. The existing hydrant lead pipe shall be disconnected from the existing tee and the existing fire hydrant, auxiliary valve, valve box, and hydrant lead pipe shall be removed. Removal of the existing fire hydrant and related components will not be paid for separately but shall be included in the cost of this work.

If the Engineer determines the existing hydrant tee and adjoining connections are in satisfactory condition, then the existing tee shall be reused, except that all of the hardware on the existing tee shall be replaced. If the Engineer determines the existing hydrant tee is in unsatisfactory condition, then the existing tee shall be removed and replaced and this work will be performed, measured and paid for as CONNECTION TO EXISTING WATER MAIN.

The fire hydrant shall be installed so that the standpipe is plumb. The center of the lowest nozzle shall be placed at least 18 in. but not more than 24 in. above finished grade. The breakable flanges shall be positioned 2 in. above finished grade. The nearest part of the hydrant shall be at least 3 ft. but not more than 8 ft. behind the back of curb. The nearest part of the hydrant shall be at least 3 ft. from all paved surfaces. Where hydrants are to be installed adjacent to a roadway they shall be placed so that the pumper nozzle faces the roadway and is perpendicular to the direction of travel of the roadway. Where hydrants are not to be installed adjacent to a roadway they shall be placed according to the plans or as directed by the Engineer.

Fire hydrants and auxiliary valves shall be set on a firm foundation of precast concrete blocks and shall be thrust blocked. Additional precast concrete bricks shall be placed under the auxiliary valve as needed. Thrust blocking shall consist of Class SI concrete cast in place against the fittings and the undisturbed earth on any side or sides of the excavation where thrust is expected to occur. A minimum of ¼ cu. yd. of concrete shall be used for the thrust blocking. The dimensions of the thrust blocking shall be determined by the Engineer. Thrust blocking may also consist of the placement of precast concrete blocks at the discretion of the Engineer. Additional precast concrete blocks shall be placed on the bottom, back and sides of the hydrant as directed by the Engineer to hold the hydrant solid and vertical. All blocks, bricks and thrust blocking shall be placed such that the pipe, joints and fittings shall be accessible for future repair and so that the hydrant drain holes are not blocked.

**MICHIGAN AVENUE IMPROVEMENT PROJECT
(CENTRAL TO KENILWORTH)
VILLAGE OF VILLA PARK**

Mechanical joint restraints shall be installed on all mechanical fittings. Stainless steel threaded tie rods shall be installed between the fire hydrant barrel and the tee fitting on the water main. Valve box stabilizer grips shall be installed. Barrel extensions will only be permitted at the discretion of the Engineer.

Fire hydrants shall be braced during backfilling. The area around the base of the hydrant shall be backfilled with a minimum of 1 cu. yd. of washed stone. The washed stone shall be covered with polyethylene sheeting prior to further backfilling. Backfill material shall be placed in lifts not exceeding 6 in. in thickness, loose measurement, and compacted in a manner approved by the Engineer.

Fire hydrants not in service shall be covered with plastic bags until the fire hydrants are in service.

Excavation, bedding, and backfilling of fire hydrants will not be paid for separately but shall be included in the cost of this work.

Method of Measurement. This work will be measured for payment as each fire hydrant with auxiliary valve and valve box installed. No separate measurement will be made of pipe, fittings, hardware, or any other components.

Basis of Payment. This work will be paid for at the contract unit price per each for FIRE HYDRANT WITH AUXILIARY VALVE AND VALVE BOX.

PAY ITEM #55-56 – WATER SERVICE CONNECTION

Description. This work shall consist of installing new copper water service connections and lines, complete in place from the water main to the existing water service line behind the curb stop, as shown on the plans or as determined by the Engineer. This work shall be in accordance with Section 562 of the Standard Specifications and with the Standard Specifications for Water and Sewer Construction in Illinois, except as modified herein.

Short service connections shall be defined as those services for properties which are located adjacent to the half of the right-of-way where the water main is located. Long service connections shall be defined as those services for properties which are located adjacent to the half of the right-of-way opposite where the water main is located.

Materials. Water service line pipe shall be Type "K" seamless copper water tubing conforming to ASTM B88, of the diameter specified. The pipe shall be marked with the manufacturer's name or trademark and with markings indicating the type of the pipe.

Corporation stops shall be Mueller 300 Ball Corporation Valve Model B-25000 with AWWA taper (Mueller "CC") thread inlet and copper flare straight connection outlet.

**MICHIGAN AVENUE IMPROVEMENT PROJECT
(CENTRAL TO KENILWORTH)
VILLAGE OF VILLA PARK**

Curb stops shall be Mueller 300 Ball Curb Valve Model B-25154 with copper flare nuts on both ends, quarter turn check, and Minneapolis pattern thread top.

Curb boxes shall be Mueller extension type curb box Model H-10302 with Minneapolis pattern base, 1-½ in. inside diameter, and 2-½ in. base tapping diameter.

Water service line couplings shall be Mueller H-15400 straight three-part unions with copper flare nuts on both ends, conforming to ANSI/AWWA C800, of the size needed.

All materials furnished as a part of this work shall comply with the latest requirements of the Federal Safe Drinking Water Act.

Construction. Where an existing water service is to be replaced, the contractor shall expose and remove the existing corporation stop. The contractor shall furnish a Smith-Blair Model #261 circle repair sleeve of the appropriate diameter and of sufficient length and shall install it on the water main.

Contractor shall make a new connection to the water main using a tapping machine satisfactory to the Engineer. Contractor shall furnish and install a new corporation stop of the appropriate diameter on the water main. The Engineer may require that the Contractor furnish and install a tapping sleeve of the appropriate size if needed.

Contractor shall install a new water service line pipe from the corporation stop to the location of the existing curb box, or to such other location as shown in the plans or as determined by the Engineer. A single piece of copper water tubing of sufficient length to extend the full distance from the water main to the curb stop shall be utilized. Splicing of multiple sections of copper water tubing will not be permitted.

The new water service line and all components shall be installed a minimum of 5.5 ft. below finished grade. Where other utilities are encountered, the new water service line shall be located so that a minimum of 1 ft. of clearance exists in all directions between the new water service line and all other utilities. Where the new water service line crosses other utilities, if installation of the new water service line above the utility being crossed would result in any portion of the new water service line being less than 5.5 ft. below finished grade, the new water service line shall be installed below the utility being crossed.

The new water service line and all components shall be placed on a bedding of crushed aggregate of CA-7 or CA-11 gradation having a minimum thickness of 4 in. The bedding shall be placed to a minimum of 12 in. above the water service line.

Contractor shall furnish and install a new curb stop of the appropriate diameter. Contractor shall connect the new curb stop to the existing water service line behind the curb stop. If the existing water service line behind the curb stop is of a different material or diameter than the new water service line being installed, a section of new copper

**MICHIGAN AVENUE IMPROVEMENT PROJECT
(CENTRAL TO KENILWORTH)
VILLAGE OF VILLA PARK**

water service line shall be installed behind the curb stop. The existing water service line shall then be cut by an approved method, and the end of the existing water service line shall be joined to the new water service line with a water service line coupling of the appropriate type and size.

Contractor shall furnish and install a new curb box. Contractor shall remove the existing curb box. Contractor shall install a piece of lath or timber adjacent to the new curb box to identify its location until final restoration takes place. Contractor shall adjust the new curb box to finished grade immediately before the placement of sodding or seeding, or the completion of any other final restoration measures. Contractor shall then remove the lath or timber.

In addition to all materials listed, Contractor shall also furnish and install all other necessary fittings, adapters, hardware, and materials necessary to complete the work as described.

Excavation, bedding, and backfilling of water service connections and lines will not be paid for separately, but shall be included in the cost of this work.

Method of Measurement. This work will be measured for payment as each water service connection and line installed, regardless of the length of the water service line, the depth of the water service line, conflicts with other utilities, or any other factors. No separate measurement will be made of pipe, fittings, couplings, stops, valves, or other components.

Basis of Payment. This work will be paid for at the contract unit price per each for WATER SERVICE CONNECTION (LONG), of the diameter specified, or WATER SERVICE CONNECTION (SHORT), of the diameter specified.

PAY ITEM #58 – ADJUSTING WATER SERVICE LINES

Description. This work shall consist of adjusting existing copper water service lines which are determined by the Engineer to be in direct conflict with utilities being constructed under this contract. This work shall be in accordance with Section 563 of the Standard Specifications and with the Standard Specifications for Water and Sewer Construction in Illinois, except as modified herein.

Materials. Water service line pipe shall be Type "K" seamless copper water tubing conforming to ASTM B88. Water service line pipe shall be of the same diameter as the existing water service line to be adjusted.

Water service line couplings shall be Mueller H-15400 straight three-part unions with copper flare nuts on both ends, conforming to ANSI/AWWA C800, of the size needed.

**MICHIGAN AVENUE IMPROVEMENT PROJECT
(CENTRAL TO KENILWORTH)
VILLAGE OF VILLA PARK**

Components in contact with potable water shall comply with the latest requirements of the Federal Safe Drinking Water Act.

Construction. Where adjustment of the water service line above the utility in conflict will result in the water service line being less than 5.5 ft. below finished grade, the water service line shall be adjusted below the utility in conflict. If the water service line is to be adjusted below the utility in conflict, adjustment of the water service line shall be completed before the utility in conflict is constructed across the water service. If the water service line is to be adjusted above the utility in conflict, adjustment of the water service line may be completed either before or after the utility in conflict is constructed across the water service line.

The existing water service line shall be cut by an approved method. If adjustment of the water service line is not to be completed immediately, both ends of the water service line shall be crimped and bagged until adjustment is to be completed. The crimped ends shall be cut again by an approved method immediately before adjustment is to be completed.

The water service line shall be adjusted so that a minimum of 1 ft. of clearance exists in all directions between the water service line and all other utilities. A single piece of copper water tubing of sufficient length to provide the minimum clearances shall be utilized. The ends of the existing water service line shall be joined to the new copper water tubing with water service line couplings of the proper size.

The adjusted water service line shall be placed on a bedding of crushed aggregate of CA-7 or CA-11 gradation having a minimum thickness of 4 in. The bedding shall be placed to a minimum of 12 in. above the adjusted water service line.

Excavation, bedding, and backfilling needed to adjust water service lines will not be paid for separately, but shall be included in the cost of this work.

Method of Measurement. This work will be measured for payment as each water service line adjusted, regardless of the length of the water service line adjusted, the depth of the water service line adjusted, the diameter of the water service line adjusted, or any other factors. No separate measurement will be made of pipe, fittings, couplings, stops, valves, or other components.

Basis of Payment. This work will only be paid for if the Engineer determines the water service line is in direct conflict with a utility or utilities being constructed under this contract. If the Engineer determines the water service line is in direct conflict with a utility or utilities being constructed under this contract, then this work will be paid for at the contract unit price per each for ADJUSTING WATER SERVICE LINES. If Contractor elects to adjust a water service line that the Engineer has not determined to be in direct conflict, that work will not be paid for but shall be at the Contractor's expense.

**MICHIGAN AVENUE IMPROVEMENT PROJECT
(CENTRAL TO KENILWORTH)
VILLAGE OF VILLA PARK**

PAY ITEM #59 – WATER MAIN RELOCATION

This work shall be done in accordance with Section 561 of the Standard Specifications, the “Standard Specifications for Water and Sewer Main Construction in Illinois” and the details on the plans except as modified herein.

561.01 Description. Revise this Article to read:

“561.01 Description. This work shall consist of adjusting water main 12 inches in diameter or less. This work shall include removal and disposal of material, all pipe and fittings, joint materials, tests, disinfection, casing pipe, and excavation.”

561.05 Basis of Payment. Revise this Article to read:

“561.05 Basis of Payment. This work shall be paid for at the contract unit price per foot for WATER MAIN RELOCATION, regardless of size up to 12 inches.

Trench backfill shall be paid for separately.”

PAY ITEM #60 – CONNECTION TO EXISTING WATER MAIN

Description. This work shall consist of making non-pressure, cut-in connections to existing water mains. This work shall be in accordance with Section 561 and Section 563 of the Standard Specifications and with the Standard Specifications for Water and Sewer Construction in Illinois, except as modified herein.

Materials. Water main pipe shall be ductile iron pipe conforming to ANSI/AWWA C151/A21.51, Class 52 standard thickness, with push-on joints conforming to AWWA C111, of the diameter required.

Water main fittings shall be ductile iron conforming to ANSI/AWWA C110/A21.10 or ANSI/AWWA C153/A21.53. Fittings shall be cement mortar lined and tar coated in accordance with AWWA C104. Fittings shall have mechanical joint end connections unless otherwise specified. Fittings shall include tees, crosses, reducers, and all other fittings as may be necessary to construct a connection to an existing water main.

Water main couplings shall be Krausz Hymax Grip coupling restraints of the diameter required, or approved equal.

Mechanical joint restraints shall be EBAA Iron, Inc., MEGALUG Mechanical Joint Restraints for Ductile Iron Pipe, or approved equal.

All bolts, nuts, washers, and other hardware to be installed below grade shall be Type 304 stainless steel.

**MICHIGAN AVENUE IMPROVEMENT PROJECT
(CENTRAL TO KENILWORTH)
VILLAGE OF VILLA PARK**

Construction. The connection to the existing water main shall be accomplished by the use of fittings of the proper types and sizes, sections of new water main pipe of the proper lengths and diameters, water main couplings of the proper sizes, and mechanical joint restraints. The connection shall be made in the most direct configuration possible. The connection may be made to the existing water main or to existing valves or fittings.

Thrust blocking of all fittings shall be in accordance with Article 41-2.10 of the Water and Sewer Specifications and the details in the plans.

The water main pipe and fittings shall be placed on a bedding of crushed aggregate of CA-7 or CA-11 gradation having a minimum thickness of 4 in. The bedding shall be placed to a minimum of 12 in. above the water main pipe and fittings.

Excavation, bedding, and backfilling will not be paid for separately but shall be included in the cost of this work.

Method of Measurement. This work will be measured for payment as each connection made, regardless of the depth of the connection, the number or type of fittings required, or any other factors. No separate measurement will be made of pipe, fittings, couplings, hardware, or any other components.

Basis of Payment. This work will be paid for at the contract unit price per each for CONNECTION TO EXISTING WATER MAIN, of the diameter specified.

PAY ITEM #61 – SANITARY SEWER SERVICE REPLACEMENT

Description. This work shall be completed in accordance with the applicable portions of the latest edition of the "Standard Specifications for Water and Sewer Main Construction in Illinois" and the requirements of the Owner of the Sanitary Sewer, and shall consist of the repair of sanitary sewer building service lines when disturbed by other construction crossing the service line or as shown on the drawings, complete in place including CCTV inspection, root removal; excavation; bracing; trench dewatering; removal of existing building service lines; repair of service lines with PVC SDR 26 ASTM 2241 pipe and stainless steel non-shear mission couplings; bedding and covering of pipe; and trench backfilling with trench backfill materials. The materials used are to be in accordance with the specifications listed in the SANITARY SEWER SERVICE RECONNECTION special provision. This Pay Item will only be used for locations shown on the drawings or if the service is in direct conflict with new utilities being installed, as determined by the Engineer.

Basis of Payment. This work will be paid for at the contract unit price per foot for SANITARY SEWER SERVICE REPLACEMENT regardless of pipe size.

**MICHIGAN AVENUE IMPROVEMENT PROJECT
(CENTRAL TO KENILWORTH)
VILLAGE OF VILLA PARK**

PAY ITEM #62 – SANITARY SEWER SERVICE RECONNECTION

Description. This work shall consist of removing and replacing the existing sanitary sewer service tee/wye connection fittings at locations shown on the drawings or at other locations as deemed necessary by the Engineer. For sanitary service reconnections in conflict with proposed utilities, this item will only be paid for if the Engineer determines the sanitary service is in direct conflict with the utility being installed as a part of this project. If the contractor elects to reconnect the sanitary sewer service connection that the Engineer has not determined to be in direct conflict, that work will be paid for at the Contractor's expense. This work shall be done in accordance with the details included as part of the contract plans. The work shall be done in accordance with applicable portions of Section 563 of the Standard Specifications.

The Contractor shall install a new polyvinyl chloride wye or tee fitting at the location of the connection on the mainline sanitary sewer. The services shall be replaced from the new wye at the mainline sanitary sewer to the existing service pipe, using PVC pipe of the same diameter as the existing connection.

The Contractor is to coordinate with the Village 48 hours prior to disconnecting the existing sanitary sewer service. During this time, the Contractor is to ensure the residences are notified of any potential interruption in services. This work is incidental to this item. After the sanitary connection has been installed the Contractor shall be responsible for locating said sanitary connection lines for the remainder of the construction. The Village will not locate sanitary connections placed by the Contractor for the duration of the project. Any damage to the sanitary connection by the Contractor caused by the Contractor's failure to properly locate the sanitary connection shall be repaired by the Contractor at his own expense to the satisfaction of the Engineer.

563.02 Materials. The materials shall be in accordance with the applicable portions of Section 550 and 563 and the Sanitary Sewer System Specifications with the following exceptions:

Replacement sewer service material shall be Polyvinyl Chloride (PVC) pipe conforming to ASTM D-2241 with gasket joints conforming to ASTM D-3212 and a Standard Dimension Ratio (SDR) equal to 26. The wye fittings to be installed on the main shall be fabricated to fit the mainline pipe that conforms to ASTM D-3034 and the branch service pipe that conforms to ASTM D-2241. All supplied pipes must be from the same manufacturer. All supplied fittings must be from the same manufacturer. All connections to existing pipes shall be made with "FERNCO" RC Series" or "MISSON Flex –Seal" adjustable non-shear repair couplings equipped with stainless steel bands. Additional fittings and labor required to connect the new 6-inch sanitary service pipe to existing service pipes that are a size other than six inches is incidental to this item.

Basis of Payment. This work will be paid for at the contract unit price for each SANITARY SEWER SERVICE RECONNECTION which price is to include all labor,

**MICHIGAN AVENUE IMPROVEMENT PROJECT
(CENTRAL TO KENILWORTH)
VILLAGE OF VILLA PARK**

equipment, excavation, sawcutting of pavement, materials, removal of existing connection, bypass pumping, removal of spoils, and reconnection of new pipe to existing pipe. If the sanitary sewer main or service pipe is required to be replaced as determined in the field by Engineer, the pipe will be paid for per linear foot as SANITARY SEWER PIPE, PVC SDR 26, ASTM D-2241, of the size specified or SANITARY SEWER SERVICE REPLACEMENT.

PAY ITEM #63 – SANITARY SEWER PIPE, PVC SDR 26 ASTM D-2241

Description. This work shall consist of the removal and replacement of sections of sanitary main sewers including providing and installing pipe, fittings and couplings; connections to manholes; all material and equipment; sawcutting; excavation; sheeting, shoring, and dewatering; by-pass pumping; removal and disposal of excavated material; bedding and covering of pipe; making connections between different pipe materials; backfilling with granular trench backfill material; and any other labor and/or materials required to complete the work as specified herein.

If required, bypass pumping may be accomplished by supplying sufficient pumping equipment to bypass the sewage flow around the construction area to the downstream sanitary sewer. Before leaving the construction site each day, the Contractor shall connect the new sewer to the existing sewer to allow sewage flow by gravity.

The sanitary sewers shall be replaced with PVC SDR 26 ASTM D-2241 pipe and the sanitary sewer main pipe diameter shall be of the same diameter as the existing pipe and sanitary sewer service pipe shall be 6" diameter. Fittings shall meet the requirements of ASTM D-3212 and ASTM F477. The above pipe and fittings shall be furnished with elastomeric gasket joints conforming to ASTM D-3139. Connections to existing sewer mains and services shall be made with No-Shear Flex Couplings with two stainless steel bands at a point where the coupling cannot shift. Bedding material shall conform to IDOT gradations CA-7 or CA-11.

Basis of Payment. This work shall be measured and paid for at the contract unit price per lineal foot as SANITARY SEWER PIPE, PVC SDR 26 ASTM D-2241 of the size specified.

PAY ITEM #64 – SANITARY MANHOLES

Description. This work shall be completed in accordance with these Special Provisions and shall consist of the installation of sanitary sewer manholes complete in place, including excavation in excess of that required for sanitary sewer; trenching; bracing, sheeting and shoring; dewatering, including erosion and siltation control methods and devices to provide protection to the environment from all pumping operation; backfilling with and compaction of excavated material or trench backfill materials; sanitary sewer

**MICHIGAN AVENUE IMPROVEMENT PROJECT
(CENTRAL TO KENILWORTH)
VILLAGE OF VILLA PARK**

manhole, including base, risers, cone, adjusting rings, steps, chimney seals, and frames and covers; watertight flexible connectors to match pipe; new pipe required to connect to manhole, connection to existing pipe, and stainless steel non-shear mission couplings; poured inverts and benches; final adjustment of frame to final grade at time of surface restoration; finish grading; removal and disposal of waste excavated material; location, protection, and repair or replacement of existing structures, pipelines and utilities; and all other work necessary for a complete sanitary sewer manhole installation.

Removal of existing manhole, if new manhole is placed in the same location, is included in the cost of this item.

Lids shall be stamped to indicate the structure type. Sanitary lids shall be stamped with "SANITARY". Stamping shall be included in the cost of the new lid. All closed lids shall be stamped with "Village of Villa Park".

Basis of Payment. This work will be paid for at the contract unit price each for SANITARY MANHOLES of the type and diameter indicated.

PAY ITEM #65 – SANITARY SEWER SERVICE COMBINATION CLEANOUT CHECK VALVE

Description. This work shall consist of furnishing and installing a combination cleanout check valve on a new or existing sanitary sewer service line at the locations shown in the plans or as determined by the Engineer. This work shall be in accordance with Section 563 of the Standard Specifications and with the Standard Specifications for Water and Sewer Construction in Illinois, except as modified herein.

This work may consist of either the standalone installation of a combination cleanout check valve on an existing sanitary sewer service line, or the installation of a combination cleanout check valve on a new sanitary sewer service line in conjunction with the installation of the new sanitary sewer service line.

Materials. Combination cleanout check valves shall be RectorSeal Clean Check Extendable Backwater Valve, 6" PVC, Model #31805, or approved equal.

Cleanout riser pipes shall be shall be polyvinyl chloride (PVC) of the diameter and type required.

Sanitary sewer service line pipe shall be polyvinyl chloride (PVC) conforming to ASTM D-2241 with a Standard Dimension Ratio (SDR) equal to 26 and gasketed joints conforming to ASTM D-3212. Sanitary sewer service line pipe shall be of the same diameter as the sanitary sewer service line on which the combination cleanout check valve is to be installed. All supplied pipe shall be from the same manufacturer.

**MICHIGAN AVENUE IMPROVEMENT PROJECT
(CENTRAL TO KENILWORTH)
VILLAGE OF VILLA PARK**

Pipe couplings shall be Fernco Shielded RC Series Couplings, Mission Rubber Company Flex-Seal ARC Sewer Repair Couplings, or approved equal. Pipe couplings shall be non-shear and shall be equipped with stainless steel bands.

Construction. The combination cleanout check valve shall be located a minimum of 4 ft. behind the back of curb. The height of the combination cleanout check valve riser pipe shall be such that the cap of the combination cleanout check valve is level with finished grade.

The combination cleanout check valve shall be assembled and installed in accordance with the manufacturer's specifications. Contractor shall provide all materials, fittings, and adapters necessary to assemble the combination cleanout check valve and to connect it to the sanitary sewer service line.

Following installation, the combination cleanout check valve shall be tested by the Contractor to confirm that there is positive flow through the sanitary sewer service line and combination cleanout check valve towards the sanitary sewer main.

Excavation, bedding, and backfilling will not be paid for separately but shall be included in the cost of this work.

Method of Measurement. This work will be measured for payment as each combination cleanout check valve installed, regardless of the depth, whether the cleanout check valve is installed on an existing sanitary sewer service line or a new sanitary sewer service line, or any other factors. No separate measurement will be made of pipe, fittings, couplings, other components.

Basis of Payment. This work will be paid for at the contract unit price per each for SANITARY SEWER SERVICE COMBINATION CLEANOUT CHECK VALVE.

PAY ITEM #66 – ADJUSTING SANITARY SEWER SERVICE LINE

Description. The work of this Pay Item shall be completed in accordance with the latest edition of the "Standard Specifications for Water and Sewer Construction in Illinois", and shall consist of the removal and replacement, or adjustment and relocation, of sanitary sewer service lines in conflict with the storm sewer at crossing locations complete in place, including connections to the existing service lines; couplings; excavation; bracing; bedding and covering of pipe; trench dewatering; finish grading; removal and disposal of waste excavated materials; protection, replacement, or repair of utilities; and backfilling with granular backfill materials.

The work shall include either the removal or replacement of service pipe at the existing location, slope, and elevation of the existing service pipe; or the vertical adjustment of the existing service pipe to cross below the storm sewer.

**MICHIGAN AVENUE IMPROVEMENT PROJECT
(CENTRAL TO KENILWORTH)
VILLAGE OF VILLA PARK**

Adjustment and relocation will require replacement of enough sanitary sewer service pipe to obtain an adequate elevation difference to cross below the water main with positive slope toward the main line sewer.

Basis of Payment. The work will be paid for at the Contract Unit Price for each ADJUSTING SANITARY SEWER SERVICE LINE, regardless of the depth, length, size, or pipe material of the sanitary sewer service.

PAY ITEM #68 – TRAFFIC CONTROL AND PROTECTION (SPECIAL)

Description. This work shall consist of the furnishing, installation, maintenance, relocation, and removal of work zone traffic control and protection. This work shall be in accordance with Section 701 of the Standard Specifications, the Supplemental Specifications, the "Illinois Manual of Uniform Traffic Control Devices", the Highway Standards and details contained in the Plans and Special Provisions, and the Special Provisions contained herein, except as modified herein.

The bid price for TRAFFIC CONTROL AND PROTECTION (SPECIAL) shall not exceed 5 percent of the total bid price. If the bid price for TRAFFIC CONTROL AND PROTECTION (SPECIAL) exceeds 5 percent of the total bid price, the Village may reject the Bid.

Special Attention is called to Article 107.09 of the Standard Specifications and the following Highway Standards, Details, Recurring Local Roads and Streets Special Provisions, and Special Provisions contained herein, relating to traffic control.

HIGHWAY STANDARDS: 701301, 701311, 701501, 701801, 701901

DETAILS:

Traffic Control and Protection for Side Roads, Intersections, and Driveways
(TC-10)
Typical Pavement Marking (TC-13)

SPECIAL PROVISIONS (Included in these Special Provisions):

Maintenance of Roadways
Work Zone Traffic Control Surveillance (LRS 3)
Flaggers in Work Zones (LRS 4)

Detour plan to be submitted for approval prior to set up.

Contractor shall contact the Village at least 72 hours in advance of beginning work. Construction operations shall be conducted in a manner such that streets shall be open

**MICHIGAN AVENUE IMPROVEMENT PROJECT
(CENTRAL TO KENILWORTH)
VILLAGE OF VILLA PARK**

to emergency traffic and accessible as required to local traffic. Advanced notice shall be provided to residents, police, fire, school districts, school bus companies, and trash haulers when access to any street will be temporarily closed or limited. Removal and replacement of curb and gutter and driveways shall be planned so as to cause a minimum of inconvenience to the abutting property owners. The work shall be accomplished such that the streets shall be left open to local traffic at the end of each workday.

Method of Measurement. This work will be measured for payment on a lump sum basis. No measurement will be made of any of the individual components of this work.

Basis of Payment. Traffic control and protection will be paid for at the contract lump sum price for TRAFFIC CONTROL AND PROTECTION (SPECIAL), which price shall include all of the above listed requirements, details, standards, and special provisions.

PAY ITEM #71 – DUST CONTROL WATERING

Description This work shall consist of the control of dust resulting from construction operations by the uniform application of sprinkled water. DUST CONTROL WATERING shall be performed when determined by the Engineer. All equipment used for this work shall be approved by the Engineer prior to beginning the work and shall be equipped with adequate measuring devices for metering the exact amount of water discharged.

Method of Measurement. Dust Control Watering will be measured for payment in units of 1000 gallons of water applied. All water used shall be properly documented by ticket or other approved means.

Basis of Payment. This work will be paid for at the contract unit price per unit for DUST CONTROL WATERING.

PAY ITEM #72 – WATER SERVICE INVESTIGATION

Description. This work shall consist of excavating around water service boxes for the purpose of determining water service pipe materials before start of project. This work shall be in accordance with Section 213 of the Standard Specifications, except as modified herein.

The water service investigation shall be used to determine the material (lead, copper, iron, etc.) of the water service on both sides of the water service box. The material shall be noted and area around the water service box restored (not paid for separately). Additional investigation shall be paid for as EXPLORATION TRENCH, SPECIAL.

**MICHIGAN AVENUE IMPROVEMENT PROJECT
(CENTRAL TO KENILWORTH)
VILLAGE OF VILLA PARK**

Contractor and private property owner can enter into a separate agreement for water service investigation inside the home, if necessary.

Method of Measurement. This work will be measured for payment as each water service investigation, regardless of depth of the water service line.

Basis of Payment. This work will be paid for at the contract unit price per each for WATER SERVICE INVESTIGATION.

PAY ITEM #73 – SANITARY SERVICE INVESTIGATION

Description. This work shall consist of excavating around existing sanitary service lines to determine depth, potential conflict with proposed underground work, and need for service main before start of project. This work shall be in accordance with Section 213 of the Standard Specifications, except as modified herein.

The sanitary service investigation shall be used to determine the depth and location of sanitary services where there is potential conflict with underground work. Based on this investigation the engineer shall determine the need for service main or re-routing of services to avoid conflict. Additional investigation shall be paid for as EXPLORATION TRENCH, SPECIAL.

Contractor and private property owner can enter into a separate agreement for sanitary service investigation inside the home, if necessary.

Method of Measurement. This work will be measured for payment as each sanitary service investigation, regardless of the length or depth of the sanitary service line.

Basis of Payment. This work will be paid for at the contract unit price per each for SANITARY SERVICE INVESTIGATION.

PAY ITEM #74 – EXPLORATION TRENCH, SPECIAL

Description. This work shall consist of constructing a trench for the purpose of locating and inspecting an existing utility or utilities. This work shall be in accordance with Section 213 of the Standard Specifications, except as modified herein.

The exploration trench may be used to locate any existing utility or utilities, including, but not limited to, water mains, water services, sewer mains, sewer services, field tiles, gas lines, underground electric lines, underground telephone lines, underground cable TV lines, underground communication lines, underground fiber optic lines, and other utilities as applicable.

**MICHIGAN AVENUE IMPROVEMENT PROJECT
(CENTRAL TO KENILWORTH)
VILLAGE OF VILLA PARK**

The exploration trench may be used to locate existing utilities regardless of whether the utilities are public or private; known or unknown; or marked or unmarked. The exploration trench may also be used to inspect the condition of existing utilities, determine the material type or dimensions of existing utilities, and to verify clearances between multiple utilities.

The exploration trench shall be constructed at the locations shown on the plans or as determined by the Engineer. The depth of the exploration trench shall vary as necessary, but shall be sufficient to locate the utility or utilities under investigation. The width of the trench shall be sufficient to allow proper investigation of the entire trench.

Upon completion of the exploration trench, the trench shall be backfilled. All exploration trenches where the inner edge of the trench is within 2 ft of an existing or proposed edge of pavement, driveway, curb, gutter, curb and gutter, stabilized shoulder, or sidewalk shall be backfilled with trench backfill in accordance with Section 208 of the Standard Specifications. Exploration trenches which do not require trench backfill shall be backfilled in accordance with Article 550.07 of the Standard Specifications. Backfilling of exploration trenches will not be measured for payment but shall be included in the cost of this work.

Method of Measurement. The exploration trench will be measured for payment in feet of actual trench constructed, regardless of the depth of the trench constructed. No additional measurement or compensation will be allowed for any delays or unforeseen circumstances arising from this work.

Basis of Payment. This work will be paid for at the contract unit price per foot for EXPLORATION TRENCH, SPECIAL.

PAY ITEM #75 – AGGREGATE TEMPORARY ACCESS (PRIVATE ENTRANCE)

Description This work shall consist of furnishing and placing aggregate for use as temporary access in accordance with section 402 of the Standard Specifications, except as modified herein.

Revise Article 402.10 of the Standard Specifications to read:

“402.10 For Temporary Access. The contractor shall construct and maintain aggregate surface course for temporary access to private and commercial entrances according to Article 402.07 and as determined by the Engineer.

The aggregate surface course shall be constructed to the dimensions and grades specified below, except as modified by the plans or as determined by the Engineer. Material shall be well graded 100 percent crushed gravel or crushed stone aggregate

**MICHIGAN AVENUE IMPROVEMENT PROJECT
(CENTRAL TO KENILWORTH)
VILLAGE OF VILLA PARK**

free of clay, loam, dirt, calcareous or other foreign matter conforming to the Standard Specifications gradation No. CA-6.

Private Entrance. The minimum width shall be 12 ft. or match full driveway width, whichever is greater. The minimum compacted thickness shall be 6 in. The maximum grade shall be eight percent, except as required to match the existing grade.

Maintaining the temporary access shall include relocating and/or regrading the aggregate surface course for any operation that may disturb or remove the temporary access. The same type and gradation of material used to construct the temporary access shall be used to maintain it.

When use of the temporary access is discontinued, the aggregate shall be removed and utilized in the permanent construction at the discretion of the Engineer or disposed of according to Article 202.03”.

402.12 Method of Measurement. Add the following to this article:

“Aggregate surface Course for temporary access will be measured for payment as each for every private or commercial entrance for the purpose of temporary access. If a residential drive or commercial entrance is to be constructed under multiple stages, the aggregate needed to construct the second or subsequent stages will not be measured for payment but shall be included in the cost per each of the type specified”.

402.13 Basis of Payment. Revise the second paragraph of this Article to read:

“Aggregate surface course for temporary access will be paid for at the contract unit price per each for AGGREGATE TEMPORARY ACCESS (PRIVATE ENTRANCE).

Partial payment of the each amount bid for temporary access, of the type specified, will be paid according to the following schedule:

(a) Upon construction of the temporary access, sixty percent of the contract unit price per each, of the type constructed, will be paid.

(b) Subject to the approval of the Engineer for the adequate maintenance and removal of the temporary access, the remaining forty percent of the pay item will be paid upon the permanent removal of the temporary access.”

PAY ITEM #76 – HOT-MIX ASPHALT TEMPORARY ACCESS (ROAD)

Description. This work shall consist of constructing temporary hot-mix asphalt ramps in accordance with Section 406 of the Standard Specifications, except as modified herein.

**MICHIGAN AVENUE IMPROVEMENT PROJECT
(CENTRAL TO KENILWORTH)
VILLAGE OF VILLA PARK**

Method of Measurement. Temporary access will be measured for payment as each for every road entrance for the purpose of temporary access. If the road is to be constructed under multiple stages, the hot-mix asphalt needed to construct the second or subsequent stages will not be measured for payment but shall be included in the cost per each.

Basis of Payment. Hot-mix asphalt surface course for temporary access will be paid for at the contract unit price per each for HOT-MIX ASPHALT TEMPORARY ACCESS (ROAD)

PAY ITEM #77 – SANITARY MANHOLES TO BE ADJUSTED

Description This work shall be done in accordance with Section 602 of the Standard Specifications and shall consist of the adjustment of sanitary manholes. Non-hardening butyl rubber mastic sealant; minimum thickness ¼-inch, shall be used between adjusting rings in place of mortar, or as required by the Owner of the Sanitary Sewer. Install new external frame seal in all locations. The installation of the external frame seal will not be paid for separately and will be considered included in this pay item.

The External Frame seal shall consist of the following:

- A. Provide frame seals consisting of a flexible external rubber sleeve and extension and stainless steel compression bands.
- B. Rubber sleeve and extension:
 1. Provide rubber sleeve and extension complying with ASTM C923.
 2. Comply with a minimum 1500 psi tensile strength, maximum 18 percent compression set and a hardness (durameter) of 48±5.
 3. Provide sleeve with a minimum thickness of 3/16-inch and unexpanded vertical heights of 6 or 9 inches.
- C. Provide extension having a minimum thickness of 3/16-inch.
- D. Compression band:
 1. Provide compression band to compress the sleeve against the manhole.
 2. Use 16 gauge stainless steel conforming to ASTM A240 Type 304 with no welded attachments and having a minimum width of 1-inch.
 3. Make a watertight seal having a minimum adjustment range of 2 diameter inches.
 4. Provide stainless steel screws, bolts, and nuts conforming to ASTM F593 and 594, Type 304.
- E. Acceptable products:
 1. Cretex Specialty Products.
 2. Or equal.
- F. Or as required by the Owner of the sanitary sewer system.

**MICHIGAN AVENUE IMPROVEMENT PROJECT
(CENTRAL TO KENILWORTH)
VILLAGE OF VILLA PARK**

The External Frame Seal shall be installed as follows:

- A. Install external rubber gasket on the manhole frame and chimney.
 - 1. Provide watertight gasket to eliminate leakage between the frame and each adjusting ring down to and including cone section.
- B. Clean surface and prepare the lower 2 inches of the manhole frame and exterior of all adjusting rings and cone section/corbel surfaces.
 - 1. Realign frame on adjusting rings or corbel as required.
- C. Repair and apply mortar grout to the adjusting rings as required to provide a smooth, circular surface for the rubber gasket.
- D. Install rubber gasket in accordance with manufacturer's recommendations.
 - 1. Field verify for suitable dimensions and layout before installation.
 - 2. Utilize sealing caulk where required.
- E. Or as required by the Owner of the sanitary sewer system.

Basis of Payment. This work will be paid for at the contract unit price per each for SANITARY MANHOLES TO BE ADJUSTED, which price shall include all of the above.

**PAY ITEM #78 – COMBINATION CONCRETE CURB AND GUTTER, TYPE B-6.12
(SPECIAL)**

Description. This work shall consist of constructing combination concrete curb and gutter as shown on the plans or as directed by the Engineer. This work shall be in accordance with Section 606 of the Standard Specifications, except as modified herein.

Excavation will not be paid for separately but shall be included in the cost of this item.

Combination concrete curb and gutter shall be constructed on a prepared base of mechanically compacted crushed aggregate of CA-6 gradation having a minimum compacted thickness of 4 in.

Wood forms shall be used. Forms constructed of steel or Masonite will not be permitted. Forms for radius sections of the combination concrete curb and gutter shall be constructed of 1 in. thick wood boards.

The height of the curb head may vary as shown on the plans or as directed by the Engineer. Variations in the height of the curb head will not be paid for separately but shall be included in the cost of this item.

Where combination concrete curb and gutter is constructed across driveways, alleys, sidewalk curb ramps, or other designated areas, the top of the curb shall be depressed according to the details shown on the plans or as directed by the Engineer. The transition from full height curb to depressed curb shall be made over a distance equal to

**MICHIGAN AVENUE IMPROVEMENT PROJECT
(CENTRAL TO KENILWORTH)
VILLAGE OF VILLA PARK**

at least four times the difference in height between the full height curb and the depressed curb.

Where combination concrete curb and gutter is constructed across sidewalk curb ramps, the depressed curb shall be in compliance with all applicable requirements of the Americans with Disabilities Act (ADA) and the Proposed Guidelines for Accessible Rights-of-Way (PROWAG).

Where combination concrete curb and gutter is to be constructed adjacent to proposed sidewalk to be constructed, the combination concrete curb and gutter shall be constructed first and shall be constructed with an integral poured ledge. The ledge shall extend horizontally a minimum of 3 in. from the back of the curb head of the combination concrete curb and gutter. The ledge shall be positioned so that the vertical distance from the top of the ledge to the top of the curb head is equal to the thickness of the proposed sidewalk. The ledge shall extend vertically to the bottom edge of the combination concrete curb and gutter. The construction of the integral poured ledge will not be paid for separately but shall be included in the cost of this item.

Expansion joints shall be constructed at 60 ft. maximum centers. Expansion joints shall also be constructed at all construction joints, all points of curvature, all points of tangency, within 5 ft. on either side of all curb structure castings, and at additional locations as directed by the Engineer. Expansion joints shall consist of a 1 in. thick preformed bituminous expansion joint filler that extends the full cross section of the combination concrete curb and gutter. Expansion joint filler material that is larger than the cross section of the combination concrete curb and gutter shall be cut to the exact cross section of the combination concrete curb and gutter.

Curb and gutter shall be continuously reinforced with 2 No. 4 bars. Where proposed curb joins existing, the expansion joint shall have two 18 in. long, No. 6 non-deformed epoxy-coated steel dowel bars placed at mid-depth. The dowel bars shall have a greased plastic expansion cap placed on one end of each dowel bar a minimum of 1 in. from the end of the dowel bar.

Where proposed combination concrete curb and gutter is to be constructed abutting existing combination concrete curb and gutter, the dowel bars shall be drilled into the existing combination concrete curb and gutter. This work will not be paid for separately but shall be included in the cost of this item.

Contraction joints shall be constructed at 15 ft. maximum centers. Where the location of a contraction joint coincides with the location of an expansion joint, the contraction joint may be omitted at the discretion of the Engineer. Contraction joints shall be tooled and sawed. Sawing of contraction joints shall commence as soon as the concrete has hardened sufficiently to permit sawing without excessive raveling, but in no case shall sawing commence less than 4 hours or more than 24 hours after the concrete is placed. Sawing of contraction joints shall be to a depth equal to 1/3 the thickness of the gutter

**MICHIGAN AVENUE IMPROVEMENT PROJECT
(CENTRAL TO KENILWORTH)
VILLAGE OF VILLA PARK**

flag and to a width of not less than 1/8 in. Contraction joints shall be sealed according to Article 420.12, except that joints shall be sealed with polysulfide or polyurethane joint sealant.

If Contractor fails to construct joints in accordance with the requirements of this provision and the curb cracks, the Contractor shall remove and replace the affected section of combination concrete curb and gutter extending the full length between the two adjacent joints on either side of the crack. This work will not be paid for but shall be at the Contractor's expense.

Upon removal of the forms from the back of the combination concrete curb and gutter, excavated areas behind the combination concrete curb and gutter shall be immediately backfilled. Areas where pavement or sidewalks are to be constructed shall be backfilled with crushed aggregate of CA-6 or CA-7 gradation and mechanically compacted. Areas where topsoil and sodding are to be placed shall be backfilled with non-organic material acceptable to the Engineer. This work will not be paid for separately but will be included in the cost of this item.

Basis of Payment. This work will be paid for at the contract unit price per foot for COMBINATION CONCRETE CURB AND GUTTER, TYPE B-6.12.

PAY ITEM #81 – PRE-CONSTRUCTION VIDEO RECORDING

Description. This work shall consist of performing color video and audio recording of the project area and other areas which may be impacted by construction.

Pre-construction video recordings will include coverage of the project area and all other areas which may be impacted by construction. Video recordings will also include construction easements when applicable. Video recordings will provide a visual record of all physical features within those areas, including, but not limited to, roadways, pavements, curbs, gutters, driveways, driveway aprons, sidewalks, carriage walks, parkways, trees, landscaping, shrubbery, plantings, landscaping walls, retaining walls, signs, sign posts, fences, utility poles, light poles, utilities, equipment, manholes, b-boxes, cleanouts, valves, curb structures, pipelines, buildings, mailboxes, and any other features located within the project area.

Video recordings will begin with an audio narrative which provides the current date and time, the name of the Village and name of project, and a description of both the starting location and the location or locations to be recorded, including street name or names, street addresses, and any additional information which may be necessary to describe the location and subject of viewing.

Video recordings will maintain viewer orientation by means of an audio commentary in the audio track of each video recording which provides an explanation of what is being

**MICHIGAN AVENUE IMPROVEMENT PROJECT
(CENTRAL TO KENILWORTH)
VILLAGE OF VILLA PARK**

viewed; and by videotaping landmarks and readily identifiable objects, including property addresses, street signs, or other appropriate objects, at appropriate intervals.

Pre-construction video recordings will be recorded at a rate of travel not exceeding 50 feet per minute, and zooming and panning rates will be controlled to provide clarity of features during playback. The finished product will be provided with bright, clear pictures and accurate colors free from distortion, tearing, rolls, or other forms of picture imperfection. The audio will have proper volume and clarity. All recordings will be performed at times of satisfactory visibility, and when no more than 10 percent of ground is obscured by snow, leaves, or other cover.

If any element within or portion of the project area is not adequately documented by the pre-construction video recording so as to definitively demonstrate its condition prior to the start of construction, Contractor will assume responsibility for the repair, restoration or replacement of that element or portion of the project area. Such repair, restoration or replacement will be to equal or better condition than previously existing, and will further comply with all standards and provisions which govern the work in question.

Schedule. Preconstruction video recording will be performed according to the following schedule:

- (a) Pre-construction video recording will be completed after a Notice to Proceed has been issued.
- (b) Pre-construction video recording will be completed after the Joint Utility Locating Information for Excavators (JULIE) request for the project area has cleared.
- (c) Pre-construction video recording will be completed before any equipment, materials, or other items are delivered to the site.
- (d) Pre-construction video recording will be completed no more than 7 chargeable days prior to the start of construction.
- (e) Pre-construction video recording will be completed, the required pre-construction video recording deliverables will be submitted to the Engineer, and the Engineer will review and issue written approval of the pre-construction video recording before any activity other than utility locating will be permitted to start. Such activity will include, but not be limited to, delivery of materials and equipment, installation of traffic control and erosion control, and completion of construction layout and tree protection. No days will be charged against the contract time while the video is under review by the Engineer, including the day the deliverables are submitted and the day a response is provided. If the pre-construction video recording or any portions

**MICHIGAN AVENUE IMPROVEMENT PROJECT
(CENTRAL TO KENILWORTH)
VILLAGE OF VILLA PARK**

thereof are rejected, the contract time will commence to run until revisions are submitted.

- (f) Pre-construction video recording will be submitted to Engineer for review prior to commencement of any construction, and receive acceptance of recordings prior to commencement of construction. Any areas found not acceptable to the Owner will be re-recorded at no additional cost to the contract.

Deliverables. Video will be high-definition, with a minimum resolution of 1280 × 720 pixels per frame. Video will be filmed in a landscape aspect ratio. Video filmed in a portrait aspect ratio will be considered unacceptable and will be rejected.

Preconstruction video recordings will be provided as electronic files of .avi, .mp4, .m4v, .mkv, .wmv, or .mpg file format, or of such other file format as may be approved by Engineer. Preconstruction video recordings will be provided as independent digital container format files, which container files will include all video, audio, and other electronic information necessary to view the preconstruction video recording as intended.

Video DVD will be considered an unacceptable format for providing preconstruction video recordings, and will be rejected.

Pre-construction video recording electronic files will be provided on a portable electronic media device or devices of one of the following types: USB flash drive, SD flash memory card, CF flash memory card, data DVD, external hard drive, or such other portable electronic media device as may be approved by Engineer. Preconstruction video recording electronic files may also be provided via online file sharing, cloud storage, File Transfer Protocol (FTP), or other online or network file transfer methods if approved by Engineer.

Pre-construction video recording electronic files will be accompanied by corresponding logs which document the dates, times, and locations covered by each preconstruction video recording electronic file.

Contractor shall maintain copies of all items submitted to Engineer for Contractor's own use and record.

Method of Measurement. This work will be measured for payment on a lump sum basis. No measurement will be made of the individual components of this effort.

Basis of Payment. Pre-construction video recording will be paid for at the contract lump sum price for PRE-CONSTRUCTION VIDEO RECORDING.

**MICHIGAN AVENUE IMPROVEMENT PROJECT
(CENTRAL TO KENILWORTH)
VILLAGE OF VILLA PARK**

PAY ITEM #82 – POST-CONSTRUCTION SEWER TELEVISIONING

Description. After work has been completed the contractor shall televise all installed sewer pipe for final inspection.

Provide closed circuit color televising (CCTV) equipment meeting following requirements:

A. Television Camera:

1. Use a digital color television camera designed and constructed for pipe inspection with the following capabilities:
2. High-resolution color-chip camera and monitor capable of producing a minimum of 650 lines of resolution.
3. Adequate and adjustable directional lighting to allow a clear picture of the entire periphery of the pipe.
4. Provide auxiliary lighting for pipes larger than 12-inch diameter.
5. Operable in 100 percent humidity conditions.
6. Use a camera that has a 360 degree radial by 270 degree pan-and tilt viewing field.
7. Remote or manually propelled.
8. Electronic footage counters accurate to less than 1 percent error over the length of the particular pipe being inspected.
9. Skids or floatation device where it is necessary to raise the camera in large pipes specifically sized for each pipe diameter to position the camera in the center of the pipe.

B. Audio-Video Recording System:

1. Provide the total audio-video recording system and procedures as required to produce a high quality digital video and audio production of bright, sharp, clear pictures with accurate colors, free from distortion. The audio portion shall have proper volume and clarity and shall be free from distortion.
2. Video Record Equipment:

**MICHIGAN AVENUE IMPROVEMENT PROJECT
(CENTRAL TO KENILWORTH)
VILLAGE OF VILLA PARK**

- a. Record inspection electronically and create DVDs directly from digital content without an intermediate analog conversion or digital format (.mpg or .avi) and submitted on CD, DVD or USB 2.0 media.
- b. Provide the documentation of the inspection.

Method of Measurement. This work will be measured for payment on a lump sum basis. No measurement will be made of the individual components of this effort.

Basis of Payment. Pre-construction video recording will be paid for at the contract lump sum price for POST-CONSTRUCTION SEWER TELEVISIONING.

PAY ITEM #83 – WATER USAGE DEDUCTION

Description. Pay items are provided as a part of this contract for the purpose of documenting the quantity of water obtained from the Village by the Contractor.

If the Contractor elects to obtain water from the Village, the Contractor shall comply with the Special Provision USE OF FIRE HYDRANTS. The quantity of water obtained from the Village by the Contractor shall be deducted from the contract as WATER USAGE DEDUCTION, and shall be credited to the contract as WATER USAGE CREDIT.

The WATER USAGE DEDUCTION pay item for this contract has been established with a unit of measurement in thousands of gallons (TGAL), a quantity of one-hundred (100.00), and a contract unit price of a deduction of eight dollars and eighty-five cents (\$8.85), for a total WATER USAGE DEDUCTION contract price of a deduction of eight-hundred eighty-five dollars and no cents (\$885.00). Bidder, in submitting a bid, accepts the quantity, contract unit price, and total contract price of the WATER USAGE DEDUCTION pay item.

Method of Measurement. Water usage will be measured as the actual quantity of water obtained from the Village by the Contractor, which quantity shall be rounded up to the nearest 1,000 gallons.

Basis of Payment. The water usage deduction will be deducted at the contract unit price per thousand gallons (TGAL) for WATER USAGE DEDUCTION. The quantity deducted as WATER USAGE DEDUCTION will be equal to the quantity paid for as WATER USAGE CREDIT.

PAY ITEM #84 – WATER USAGE CREDIT

Description. Pay items are provided as a part of this contract for the purpose of documenting the quantity of water obtained from the Village by the Contractor.

**MICHIGAN AVENUE IMPROVEMENT PROJECT
(CENTRAL TO KENILWORTH)
VILLAGE OF VILLA PARK**

If the Contractor elects to obtain water from the Village, the Contractor shall comply with the Special Provision USE OF FIRE HYDRANTS. The quantity of water obtained from the Village by the Contractor shall be deducted from the contract as WATER USAGE DEDUCTION, and shall be credited to the contract as WATER USAGE CREDIT.

The WATER USAGE CREDIT pay item for this contract has been established with a unit of measurement in thousands of gallons (TGAL), a quantity of one-hundred (100.00), and a contract unit price of eight dollars and eighty-five cents (\$8.85), for a total WATER USAGE CREDIT contract price of eight-hundred eighty-five dollars and no cents (\$885.00). Bidder, in submitting a bid, accepts the quantity, contract unit price, and total contract price of the WATER USAGE CREDIT pay item.

Method of Measurement. Water usage will be measured as the actual quantity of water obtained from the Village by the Contractor, which quantity shall be rounded up to the nearest 1,000 gallons.

Basis of Payment. The water usage credit will be paid for at the contract unit price per thousand gallons (TGAL) for WATER USAGE CREDIT. The quantity paid for as WATER USAGE CREDIT will be equal to the quantity deducted as WATER USAGE DEDUCTION.

PAY ITEM #85 – CONTINGENCY ALLOWANCE

Description. A contingency allowance pay item is provided as a part of this contract for the purpose of facilitating the completion of unforeseen or additional work not included in the contract as awarded, and which is determined by the Engineer to be necessary and germane to the contract.

Use of the contingency allowance will be at the discretion of the Engineer. The Engineer may, at the Engineer's discretion, use the contingency allowance for any of the following reasons:

- (a) Facilitate a temporary payment allowance to the Contractor for work completed under existing contract pay items and for which completed quantities exceed contract quantities;
- (b) Facilitate a temporary payment allowance to the Contractor for work completed beyond the scope of existing contract pay items; or
- (c) Facilitate a temporary payment allowance to the Contractor for the purchase of equipment, materials or such other requisition as Engineer determines to be necessary for the completion of the Work.

**MICHIGAN AVENUE IMPROVEMENT PROJECT
(CENTRAL TO KENILWORTH)
VILLAGE OF VILLA PARK**

Such use of the CONTINGENCY ALLOWANCE will be further subject to approval by the Village. The Village's decision with regard to use of the CONTINGENCY ALLOWANCE will be final.

- A. Any payments made to Contractor under the CONTINGENCY ALLOWANCE will be considered temporary, and will only be retained by Contractor until such time that an authorization of contract changes can be approved and incorporated into the contract.
- B. Contractor, in accepting payments made under the CONTINGENCY ALLOWANCE, agrees to the terms of this and other applicable special provisions. Contractor agrees to relinquish any monies and any claim to monies paid under the CONTINGENCY ALLOWANCE upon approval of an authorization of contract changes and payment for any work for which payment was previously made under the CONTINGENCY ALLOWANCE. Contractor further agrees to return any monies previously paid thereunder.
- C. The CONTINGENCY ALLOWANCE pay item for this contract has been established with a unit of measurement in dollars, a quantity of 30,000.00, and a contract unit price of one dollar (\$1.00), for a total CONTINGENCY ALLOWANCE contract price of Thirty Thousand dollars and no cents (\$30,000.00). Bidder, in submitting a bid, accepts the quantity, contract unit price, and total contract price of the CONTINGENCY ALLOWANCE.

Basis of Payment. This work will be paid for at the contract unit price per dollar for CONTINGENCY ALLOWANCE. The total bid amount for this item will be \$30,000.00.

**MICHIGAN AVENUE IMPROVEMENT PROJECT
(CENTRAL TO KENILWORTH)
VILLAGE OF VILLA PARK**

DRAINAGE AND INLET PROTECTION UNDER TRAFFIC (DISTRICT 1)

Effective: April 1, 2011
Revised: April 2, 2011

Add the following to Article 603.02 of the Standard Specifications:

- “(i) Temporary Hot-Mix Asphalt (HMA) Ramp (Note 1) 1030
- “(j) Temporary Rubber Ramps (Note 2)

Note 1. The HMA shall have maximum aggregate size of 3/8 in. (95 mm).

Note 2. The rubber material shall be according to the following.

Property	Test Method	Requirement
Durometer Hardness, Shore A	ASTM D 2240	75 ±15
Tensile Strength, psi (kPa)	ASTM D 412	300 (2000) min
Elongation, percent	ASTM D 412	90 min
Specific Gravity	ASTM D 792	1.0 - 1.3
Brittleness, °F (°C)	ASTM D 746	-40 (-40)”

Revise Article 603.07 of the Standard Specifications to read:

“603.07 Protection Under Traffic. After the casting has been adjusted and the Class PP concrete has been placed, the work shall be protected by a barricade and two lights according to Article 701.17(e)(3)b.

When castings are under traffic before the final surfacing operation has been started, properly sized temporary ramps shall be placed around the drainage and/or utility castings according to the following methods.

- (a) Temporary Asphalt Ramps. Temporary hot-mix asphalt ramps shall be placed around the casting, flush with its surface and decreasing to a featheredge in a distance of 2 ft (600 mm) around the entire surface of the casting.
- (b) Temporary Rubber Ramps. Temporary rubber ramps shall only be used on roadways with permanent posted speeds of 40 mph or less and when the height of the casting to be protected meets the proper sizing requirements for the rubber ramps as shown below.

Dimension	Requirement
Inside Opening	Outside dimensions of casting + 1 in. (25 mm)
Thickness at inside edge	Height of casting ± 1/4 in. (6 mm)

**MICHIGAN AVENUE IMPROVEMENT PROJECT
(CENTRAL TO KENILWORTH)
VILLAGE OF VILLA PARK**

Thickness at outside edge	1/4 in. (6 mm) max.
Width, measured from inside opening to outside edge	8 1/2 in. (215 mm) min

Placement shall be according to the manufacturer's specifications.

Temporary ramps for castings shall remain in place until surfacing operations are undertaken within the immediate area of the structure. Prior to placing the surface course, the temporary ramp shall be removed. Excess material shall be disposed of according to Article 202.03."

COARSE AGGREGATE FOR BACKFILL, TRENCH BACKFILL AND BEDDING (D-1)

Effective: November 1, 2011

Revised: November 1, 2013

This work shall be according to Section 1004.05 of the Standard Specifications except for the following:

Reclaimed Asphalt Pavement (RAP) maybe blended with gravel, crushed gravel, crushed stone crushed concrete, crushed slag, chats, crushed sand stone or wet bottom boiler slag. The RAP used shall be according to the current Bureau of Materials and Physical Research Policy Memorandum, "Reclaimed Asphalt Pavement (RAP) for Aggregate Applications". The RAP shall be uniformly graded and shall pass the 1.0 in. (25 mm) screen. When RAP is blended with any of the coarse aggregate listed above, the blending shall be done mechanically with calibrated feeders. The feeders shall have an accuracy of ± 2.0 percent of the actual quantity of material delivered. The final blended product shall not contain more than 40 percent by weight RAP.

The coarse aggregate listed above shall meet CA 6 and CA 10 gradations prior to being blended with the processed and uniformly graded RAP. Gradation deleterious count shall not exceed 10% of total RAP and 5% of other by total weight.

**MICHIGAN AVENUE IMPROVEMENT PROJECT
(CENTRAL TO KENILWORTH)
VILLAGE OF VILLA PARK**

HOT-MIX ASPHALT BINDER AND SURFACE COURSE (D-1)

Effective: November 1, 2019
Revised: February 2, 2020

Description. This work shall consist of constructing a hot-mix asphalt (HMA) binder and/or surface course on a prepared base. Work shall be according to Sections 406 and 1030 of the Standard Specifications, except as modified herein.

Materials. Revise Article 1004.03(c) to read:

“ (c) Gradation. The coarse aggregate gradations shall be as listed in the following table.

Use	Size/Application	Gradation No.
Class A-1, A-2, & A-3	3/8 in. (10 mm) Seal	CA 16 or CA 20
Class A-1	1/2 in. (13 mm) Seal	CA 15
Class A-2 & A-3	Cover Coat	CA 14
HMA High ESAL	IL-19.0; Stabilized Subbase IL-19.0	CA 11 ^{1/}
	SMA 12.5 ^{2/}	CA 13 ^{4/} , CA 14, or CA 16
	SMA 9.5 ^{2/}	CA 13 ^{3/4/} or CA 16 ^{3/}
	IL-9.5	CA 16, CM 13 ^{4/}
	IL-9.5FG	CA 16
HMA Low ESAL	IL-19.0L	CA 11 ^{1/}
	IL-9.5L	CA 16

- 1/ CA 16 or CA 13 may be blended with the CA 11.
- 2/ The coarse aggregates used shall be capable of being combined with stone sand, slag sand, or steel slag sand meeting the FA/FM 20 gradation and mineral filler to meet the approved mix design and the mix requirements noted herein.
- 3/ The specified coarse aggregate gradations may be blended.
- 4/ CA 13 shall be 100 percent passing the 1/2 in. (12.5mm) sieve.”

Revise Article 1004.03(e) of the Supplemental Specifications to read:

“(e) Absorption. For SMA the coarse aggregate shall also have water absorption ≤ 2.0 percent.”

HMA Nomenclature. Revise the “High ESAL” portion of the table in Article 1030.01 to read:

**MICHIGAN AVENUE IMPROVEMENT PROJECT
(CENTRAL TO KENILWORTH)
VILLAGE OF VILLA PARK**

"High ESAL	Binder Courses	IL-19.0, IL-9.5, IL-9.5FG, IL-4.75, SMA 12.5, Stabilized Subbase IL-19.0
	Surface Courses	IL-9.5, IL-9.5FG, SMA 12.5, SMA 9.5"

Revise Article 1030.02 of the Standard Specifications and Supplemental Specifications to read:

"1030.02 Materials. Materials shall be according to the following.

Item	Article/Section
(a) Coarse Aggregate	1004.03
(b) Fine Aggregate	1003.03
(c) RAP Material	1031
(d) Mineral Filler	1011
(e) Hydrated Lime	1012.01
(f) Slaked Quicklime (Note 1)	
(g) Performance Graded Asphalt Binder (Note 2)	1032
(h) Fibers (Note 3)	
(i) Warm Mix Asphalt (WMA) Technologies (Note 4)	

Note 1. Slaked quicklime shall be according to ASTM C 5.

Note 2. The asphalt binder shall be an SBS PG 76-28 when the SMA is used on a full-depth asphalt pavement and SBS PG 76-22 when used as an overlay, except where modified herein. The asphalt binder shall be a SBS PG 76-22 for IL-4.75, except where modified herein. The elastic recovery shall be a minimum of 80.

Note 3. A stabilizing additive such as cellulose or mineral fiber shall be added to the SMA mixture according to Illinois Modified AASHTO M 325. The stabilizing additive shall meet the Fiber Quality Requirements listed in Illinois Modified AASHTO M 325. Prior to approval and use of fibers, the Contractor shall submit a notarized certification by the producer of these materials stating they meet these requirements. Reclaimed Asphalt Shingles (RAS) may be used in Stone Matrix Asphalt (SMA) mixtures designed with an SBA polymer modifier as a fiber additive if the mix design with RAS included meets AASHTO T305 requirements. The RAS shall be from a certified source that produces either Type I or Type 2. Material shall meet requirements noted herein and the actual dosage rate will be determined by the Engineer.

Note 4. Warm mix additives or foaming processes shall be selected from the Department's Qualified Producer List, "Technologies for the Production of Warm Mix Asphalt (WMA)".

Mixture Design. Revise Article 1030.04(a)(1) of the Standard Specifications and the Supplemental Specifications to read:

**MICHIGAN AVENUE IMPROVEMENT PROJECT
(CENTRAL TO KENILWORTH)
VILLAGE OF VILLA PARK**

High ESAL, MIXTURE COMPOSITION (% PASSING) ^{1/}										
Sieve Size	IL-19.0 mm		SMA 12.5		SMA 9.5		IL-9.5mm		IL-4.75 mm	
	min	max	min	max	min	max	min	max	min	max
1 1/2 in. (37.5 mm)										
1 in. (25 mm)		100								
3/4 in. (19 mm)	90	100		100						
1/2 in. (12.5 mm)	75	89	80	100		100		100		100
3/8 in. (9.5 mm)				65	90	100	90	100		100
#4 (4.75 mm)	40	60	20	30	36	50	34	69	90	100
#8 (2.36 mm)	20	42	16	24 ^{4/}	16	32 ^{4/}	34 ^{5/}	52 ^{2/}	70	90
#16 (1.18 mm)	15	30					10	32	50	65
#30 (600 μm)			12	16	12	18				
#50 (300 μm)	6	15					4	15	15	30
#100 (150 μm)	4	9					3	10	10	18
#200 (75 μm)	3	6	7.0	9.0 ^{3/}	7.5	9.5 ^{3/}	4	6	7	9 ^{3/}
#635 (20 μm)			≤ 3.0		≤ 3.0					
Ratio Dust/Asphalt Binder		1.0		1.5		1.5		1.0		1.0

- 1/ Based on percent of total aggregate weight.
- 2/ The mixture composition shall not exceed 44 percent passing the #8 (2.36 mm) sieve for surface courses with N_{design} = 90.
- 3/ Additional minus No. 200 (0.075 mm) material required by the mix design shall be mineral filler, unless otherwise approved by the Engineer.
- 4/ When establishing the Adjusted Job Mix Formula (AJMF) the percent passing the #8 (2.36 mm) sieve shall not be adjusted above the percentage stated on the table.
- 5/ When establishing the Adjusted Job Mix Formula (AJMF) the percent passing the #8 (2.36 mm) sieve shall not be adjusted below 34 percent.

Revise Article 1030.04(b)(1) of the Standard Specifications to read:

**MICHIGAN AVENUE IMPROVEMENT PROJECT
(CENTRAL TO KENILWORTH)
VILLAGE OF VILLA PARK**

“(1) High ESAL Mixtures. The target value for the air voids of the HMA shall be 4.0 percent, for IL-4.75 it shall be 3.5 percent and for Stabilized Subbase it shall be 3.0 percent at the design number of gyrations. The voids in the mineral aggregate (VMA) and voids filled with asphalt binder (VFA) of the HMA design shall be based on the nominal maximum size of the aggregate in the mix and shall conform to the following requirements.

VOLUMETRIC REQUIREMENTS High ESAL				
Ndesign	Voids in the Mineral Aggregate (VMA), % minimum			Voids Filled with Asphalt Binder (VFA), %
	IL-19.0; Stabilized Subbase IL- 19.0	IL-9.5	IL-4.75 ^{1/}	
50	13.5	15.0	18.5	65 – 78 ^{2/}
70				
90				

1/ Maximum draindown for IL-4.75 shall be 0.3 percent.

2/ VFA for IL-4.75 shall be 72-85 percent.”

Revise the table in Article 1030.04(b)(3) to read:

“VOLUMETRIC REQUIREMENTS, SMA 12.5 ^{1/} and SMA 9.5 ^{1/}			
Ndesign	Design Air Voids Target %	Voids in the Mineral Aggregate (VMA), % min.	Voids Filled with Asphalt (VFA), %
80 ^{4/}	3.5	17.0 ^{2/}	75 - 83
		16.0 ^{3/}	

1/ Maximum draindown shall be 0.3 percent. The draindown shall be determined at the JMF asphalt binder content at the mixing temperature plus 30 °F.

2/ Applies when specific gravity of coarse aggregate is ≥ 2.760.

3/ Applies when specific gravity of coarse aggregate is < 2.760.

4/ Blending of different types of aggregate will not be permitted. For surface course, the coarse aggregate can be crushed steel slag, crystalline crushed stone or crushed sandstone. For binder course, coarse

**MICHIGAN AVENUE IMPROVEMENT PROJECT
(CENTRAL TO KENILWORTH)
VILLAGE OF VILLA PARK**

aggregate shall be crushed stone (dolomite), crushed gravel, crystalline crushed stone, or crushed sandstone.

Add to the end of Article 1030.05 (d) (2) a. of the Standard Specifications:

“During production, the Contractor shall test SMA mixtures for draindown according to AASHTO T305 at a frequency of 1 per day of production.”

Revise the last paragraph of Article 1102.01 (a) (5) of the Standard Specifications to read:

“IL-4.75 and Stone Matrix Asphalt (SMA) mixtures which contain aggregate having absorptions greater than or equal to 2.0 percent, or which contain steel slag sand, shall have minimum surge bin storage plus haul time of 1.5 hours.”

Quality Control/Quality Assurance (QC/QA). Revise the third paragraph of Article 1030.05(d)(3) to read:

“If the Contractor and Engineer agree the nuclear density test method is not appropriate for the mixture, cores shall be taken at random locations determined according to the QC/QA document "Determination of Random Density Test Site Locations". Core densities shall be determined using the Illinois Modified AASHTO T 166 or T 275 procedure.”

Add the following paragraphs to the end of Article 1030.05(d)(3):

“Longitudinal joint density testing shall be performed at each random density test location. Longitudinal joint testing shall be located at a distance equal to the lift thickness or a minimum of 4 in. (100 mm), from each pavement edge (i.e. for a 5 in. (125 mm) lift the near edge of the density gauge or core barrel shall be within 5 in. (125 mm) from the edge of pavement). Longitudinal joint density testing shall be performed using either a correlated nuclear gauge or cores.

- a. Confined Edge. Each confined edge density shall be represented by a one-minute nuclear density reading or a core density and shall be included in the average of density readings or core densities taken across the mat which represents the Individual Test.
- b. Unconfined Edge. Each unconfined edge joint density shall be represented by an average of three one-minute density readings or a single core density at the given density test location and shall meet the density requirements specified herein. The three one-minute readings shall be spaced 10 ft (3 m) apart longitudinally along the unconfined pavement edge and centered at the random density test location.

When a longitudinal joint sealant (LJS) is applied, longitudinal joint density testing will not be required on the joint(s) sealed.”

Revise the second table in Article 1030.05(d)(4) and its notes to read:

**MICHIGAN AVENUE IMPROVEMENT PROJECT
(CENTRAL TO KENILWORTH)
VILLAGE OF VILLA PARK**

"DENSITY CONTROL LIMITS			
Mixture Composition	Parameter	Individual Test (includes confined edges)	Unconfined Edge Joint Density, minimum
IL-4.75	Ndesign = 50	93.0 – 97.4 % ^{1/}	91.0%
IL-9.5FG	Ndesign = 50 - 90	93.0 – 97.4 %	91.0%
IL-9.5	Ndesign = 90	92.0 – 96.0 %	90.0%
IL-9.5, IL-9.5L,	Ndesign < 90	92.5 – 97.4 %	90.0%
IL-19.0	Ndesign = 90	93.0 – 96.0 %	90.0%
IL-19.0, IL-19.0L	Ndesign < 90	93.0 ^{2/} – 97.4 %	90.0%
SMA	Ndesign = 80	93.5 – 97.4 %	91.0%

1/ Density shall be determined by cores or by correlated, approved thin lift nuclear gauge.

2/ 92.0 % when placed as first lift on an unimproved subgrade."

Equipment. Add the following to Article 1101.01 of the Standard Specifications:

"(h) Oscillatory Roller. The oscillatory roller shall be self-propelled and provide a smooth operation when starting, stopping, or reversing directions. The oscillatory roller shall be able to operate in a mode that will provide tangential impact force with or without vertical impact force by using at least one drum. The oscillatory roller shall be equipped with water tanks and sprinkling devices, or other approved methods, which shall be used to wet the drums to prevent material pickup. The drum(s) amplitude and frequency of the tangential and vertical impact force shall be approximately the same in each direction and meet the following requirements:

- (1) The minimum diameter of the drum(s) shall be 42 in. (1070 mm);
- (2) The minimum length of the drum(s) shall be 57 in. (1480 mm);
- (3) The minimum unit static force on the drum(s) shall be 125 lb/in. (22 N/m); and
- (4) The minimum force on the oscillatory drum shall be 18,000 lb (80 kN)."

Construction Requirements.

Add the following to Article 406.03 of the Standard Specifications:

"(j) Oscillatory Roller 1101.01"

Revise the third paragraph of Article 406.05(a) to read:

**MICHIGAN AVENUE IMPROVEMENT PROJECT
(CENTRAL TO KENILWORTH)
VILLAGE OF VILLA PARK**

“All depressions of 1 in. (25 mm) or more in the surface of the existing pavement shall be filled with binder. At locations where heavy disintegration and deep spalling exists, the area shall be cleaned of all loose and unsound material, tacked, and filled with binder (hand method).”

Revise Article 406.05(c) to read.

“(c) Binder (Hand Method). Binder placed other than with a finishing machine will be designated as binder (hand method) and shall be compacted with a roller to the satisfaction of the Engineer. Hand tamping will be permitted when approved by the Engineer.”

Revise the special conditions for mixture IL-4.75 in Article 406.06(b)(2)e. to read:

“e. The mixture shall be overlaid within 5 days of being placed.”

Revise Article 406.06(d) to read:

“(d) Lift Thickness. The minimum compacted lift thickness for HMA binder and surface courses shall be as follows.

MINIMUM COMPACTED LIFT THICKNESS	
Mixture Composition	Thickness, in. (mm)
IL-4.75	3/4 (19) - over HMA surfaces ^{1/} 1 (25) - over PCC surfaces ^{1/}
IL-9.5FG	1 1/4 (32)
IL-9.5, IL-9.5L	1 1/2 (38)
SMA 9.5	1 3/4 (45)
SMA 12.5	2 (51)
IL-19.0, IL-19.0L	2 1/4 (57)

1/ The maximum compacted lift thickness for mixture IL-4.75 shall be 1 1/4 in. (32 mm).”

Revise Table 1 and Note 3/ of Table 1 in Article 406.07(a) of the Standard Specifications to read:

“TABLE 1 - MINIMUM ROLLER REQUIREMENTS FOR HMA				
	Breakdown Roller (one of the following)	Intermediate Roller	Final Roller (one or more of the following)	Density Requirement
Binder and Surface ^{1/}	V _D , P ^{3/} , T _B , 3W, O _T , O _B	P ^{3/} , O _T , O _B	V _S , T _B , T _F , O _T	As specified in Articles: 1030.05(d)(3), (d)(4), and

**MICHIGAN AVENUE IMPROVEMENT PROJECT
(CENTRAL TO KENILWORTH)
VILLAGE OF VILLA PARK**

				(d)(7).
IL-4.75 and SMA ^{4/5/}	T _B , 3W, O _T	--	T _F , 3W, O _T	
Bridge Decks ^{2/}	T _B	--	T _F	As specified in Articles 582.05 and 582.06.

3/ A vibratory roller (V_D) or oscillatory roller (O_T or O_B) may be used in lieu of the pneumatic-tired roller on mixtures containing polymer modified asphalt binder.”

Add the following to EQUIPMENT DEFINITION in Article 406.07(a) contained in the Errata of the Supplemental Specifications:

“O_T - Oscillatory roller, tangential impact mode. Maximum speed is 3.0 mph (4.8 km/h) or 264 ft/min (80 m/min).

O_B - Oscillatory roller, tangential and vertical impact mode, operated at a speed to produce not less than 10 vertical impacts/ft (30 impacts/m).”

Delete last sentence of the second paragraph of Article 1102.01(a) (4) b. 2.

Add to the end of Article 1102.01 (a) (4) b. 2.:

“As an option, collected dust (baghouse) may be used in lieu of manufactured mineral filler according to the following:

(a.) Sufficient collected dust (baghouse) is available for production of the SMA mix for the entire project.

(b.) A mix design was prepared based on collected dust (baghouse).

Revise Article 1030.04 (d) of the Standard Specifications to read:

“(d) Verification Testing. High ESAL, IL-4.75, and SMA mix designs submitted for verification will be tested to ensure that the resulting mix designs will pass the required criteria for the Hamburg Wheel Test (IL mod AASHTO T-324) and the Tensile Strength Test (IL mod AASHTO T-283). The Department will perform a verification test on gyratory specimens compacted by the Contractor. If the mix fails the Department’s verification test, the Contractor shall make the necessary changes to the mix and resubmit compacted specimens to the Department for verification. If the mix fails again, the mix design will be rejected.

All new mix designs will be required to be tested, prior to submittal for Department verification and shall meet the following requirements:

(1) Hamburg Wheel Test criteria. The maximum allowable rut depth shall be 0.5 in. (12.5 mm). The minimum number of wheel passes at the 0.5 in. (12.5 mm) rut depth criteria shall be based on the high temperature binder grade of the mix as specified in the mix requirements table of the plans.

**MICHIGAN AVENUE IMPROVEMENT PROJECT
(CENTRAL TO KENILWORTH)
VILLAGE OF VILLA PARK**

Illinois Modified AASHTO T 324 Requirements ^{1/}

Asphalt Binder Grade	# Repetitions	Max Rut Depth (mm)
PG 70 -XX (or higher)	20,000	12.5
PG 64 -XX (or lower)	10,000	12.5

1/ When produced at temperatures of 275 ± 5 °F (135 ± 3 °C) or less, loose Warm Mix Asphalt shall be oven aged at 270 ± 5 °F (132 ± 3 °C) for two hours prior to gyratory compaction of Hamburg Wheel specimens.

Note: For SMA Designs (N-80) the maximum rut depth is 6.0 mm at 20,000 repetitions.

For IL 4.75mm Designs (N-50) the maximum rut depth is 9.0mm at 15,000 repetitions.

(2) Tensile Strength Criteria. The minimum allowable conditioned tensile strength shall be 60 psi (415 kPa) for non-polymer modified performance graded (PG) asphalt binder and 80 psi (550 kPa) for polymer modified PG asphalt binder. The maximum allowable unconditioned tensile strength shall be 200 psi (1380 kPa)."

Production Testing. Revise first paragraph of Article 1030.06(a) of the Standard Specifications to read:

"(a) High ESAL, IL-4.75, WMA, and SMA Mixtures. For each contract, a 300 ton (275 metric tons) test strip, except for SMA mixtures it will be 400 ton (363 metric ton), will be required at the beginning of HMA production for each mixture at the beginning of each construction year according to the Manual of Test Procedures for Materials "Hot Mix Asphalt Test Strip Procedures". At the request of the Producer, the Engineer may waive the test strip if previous construction during the current construction year has demonstrated the constructability of the mix using Department test results."

Add the following after the sixth paragraph in Article 1030.06 (a) of the Standard Specifications:

"The Hamburg Wheel test shall also be conducted on all HMA mixtures from a sample taken within the first 500 tons (450 metric tons) on the first day of production or during start up with a split reserved for the Department. The mix sample shall be tested according to the Illinois Modified AASHTO T 324 and shall meet the requirements specified herein. Mix production shall not exceed 1500 tons (1350 metric tons) or one day's production, whichever comes first, until the testing is completed and the mixture is found to be in conformance. The requirement to cease mix production may be waived if the plant produced mixture demonstrates conformance prior to start of mix production for a contract.

If the mixture fails to meet the Hamburg Wheel criteria, no further mixture will be accepted until the Contractor takes such action as is necessary to furnish a mixture meeting the criteria"

Method of Measurement:

**MICHIGAN AVENUE IMPROVEMENT PROJECT
(CENTRAL TO KENILWORTH)
VILLAGE OF VILLA PARK**

Add the following after the fourth paragraph of Article 406.13 (b):

“The plan quantities of SMA mixtures shall be adjusted using the actual approved binder and surface Mix Design’s Gmb.”

Basis of Payment. Replace the second through the fifth paragraphs of Article 406.14 with the following:

“ HMA binder and surface courses will be paid for at the contract unit price per ton (metric ton) for MIXTURE FOR CRACKS, JOINTS, AND FLANGEWAYS; HOT-MIX ASPHALT BINDER COURSE (HAND METHOD), of the Ndesign specified; HOT-MIX ASPHALT BINDER COURSE, of the mixture composition and Ndesign specified; HOT-MIX ASPHALT SURFACE COURSE, of the mixture composition, friction aggregate, and Ndesign specified; POLYMERIZED HOT-MIX ASPHALT BINDER COURSE (HAND METHOD), of the Ndesign specified; POLYMERIZED HOT-MIX ASPHALT BINDER COURSE, of the mixture composition and Ndesign specified; POLYMERIZED HOT-MIX ASPHALT SURFACE COURSE, of the mixture composition, friction aggregate, and Ndesign specified; POLYMERIZED HOT-MIX ASPHALT BINDER COURSE, STONE MATRIX ASPHALT, of the mixture composition and Ndesign specified; POLYMERIZED HOT-MIX ASPHALT SURFACE COURSE, STONE MATRIX ASPHALT, of the mixture composition, friction aggregate, and Ndesign specified.”

GROUND TIRE RUBBER (GTR) MODIFIED ASPHALT BINDER (D-1)

Effective: June 26, 2006

Revised: April 1, 2016

Add the following to the end of article 1032.05 of the Standard Specifications:

“(c) Ground Tire Rubber (GTR) Modified Asphalt Binder. A quantity of 10.0 to 14.0 percent GTR (Note 1) shall be blended by dry unit weight with a PG 64-28 to make a GTR 70-28 or a PG 58-28 to make a GTR 64-28. The base PG 64-28 and PG 58-28 asphalt binders shall meet the requirements of Article 1032.05(a). Compatible polymers may be added during production. The GTR modified asphalt binder shall meet the requirements of the following table.

Test	Asphalt Grade 70-28	GTR	Asphalt Grade GTR 64-28
Flash Point (C.O.C.), AASHTO T 48, °F (°C), min.	450 (232)		450 (232)
Rotational Viscosity, AASHTO T 316 @ 275 °F (135 °C), Poises, Pa·s, max.	30 (3)		30 (3)

**MICHIGAN AVENUE IMPROVEMENT PROJECT
(CENTRAL TO KENILWORTH)
VILLAGE OF VILLA PARK**

Softening Point, AASHTO T 53, °F (°C), min.	135 (57)	130 (54)
Elastic Recovery, ASTM D 6084, Procedure A (sieve waived) @ 77 °F, (25 °C), aged, ss, 100 mm elongation, 5 cm/min., cut immediately, %, min.	65	65

Note 1. GTR shall be produced from processing automobile and/or light truck tires by the ambient grinding method. GTR shall not exceed 1/16 in. (2 mm) in any dimension and shall contain no free metal particles or other materials. A mineral powder (such as talc) meeting the requirements of AASHTO M 17 may be added, up to a maximum of four percent by weight of GTR to reduce sticking and caking of the GTR particles. When tested in accordance with Illinois modified AASHTO T 27, a 50 g sample of the GTR shall conform to the following gradation requirements:

Sieve Size	Percent Passing
No. 16 (1.18 mm)	100
No. 30 (600 μm)	95 ± 5
No. 50 (300 μm)	> 20

Add the following to the end of Note 1. of article 1030.03 of the Standard Specifications:

“A dedicated storage tank for the Ground Tire Rubber (GTR) modified asphalt binder shall be provided. This tank must be capable of providing continuous mechanical mixing throughout by continuous agitation and recirculation of the asphalt binder to provide a uniform mixture. The tank shall be heated and capable of maintaining the temperature of the asphalt binder at 300 °F to 350 °F (149 °C to 177 °C). The asphalt binder metering systems of dryer drum plants shall be calibrated with the actual GTR modified asphalt binder material with an accuracy of ± 0.40 percent.”

Revise 1030.02(c) of the Standard Specifications to read:

“(c) RAP Materials (Note 5)1031”

Add the following note to 1030.02 of the Standard Specifications:

Note 5. When using reclaimed asphalt pavement and/or reclaimed asphalt shingles, the maximum asphalt binder replacement percentage shall be according to the most recent special provision for recycled materials.

**MICHIGAN AVENUE IMPROVEMENT PROJECT
(CENTRAL TO KENILWORTH)
VILLAGE OF VILLA PARK**

FRICTION AGGREGATE (D-1)

Effective: January 1, 2011
Revised: November 1, 2019

Revise Article 1004.03(a) of the Standard Specifications to read:

"1004.03 Coarse Aggregate for Hot-Mix Asphalt (HMA). The aggregate shall be according to Article 1004.01 and the following.

(a) Description. The coarse aggregate for HMA shall be according to the following table.

Use	Mixture	Aggregates Allowed
Class A	Seal or Cover	<u>Allowed Alone or in Combination</u> ^{5/} : Gravel Crushed Gravel Carbonate Crushed Stone Crystalline Crushed Stone Crushed Sandstone Crushed Slag (ACBF) Crushed Steel Slag Crushed Concrete
HMA Low ESAL	Stabilized Subbase or Shoulders	<u>Allowed Alone or in Combination</u> ^{5/} : Gravel Crushed Gravel Carbonate Crushed Stone Crystalline Crushed Stone Crushed Sandstone Crushed Slag (ACBF) Crushed Steel Slag ^{1/} Crushed Concrete
HMA High ESAL Low ESAL	Binder IL-19.0 or IL-19.0L SMA Binder	<u>Allowed Alone or in Combination</u> ^{5/ 6/} : Crushed Gravel Carbonate Crushed Stone ^{2/} Crystalline Crushed Stone Crushed Sandstone Crushed Slag (ACBF) Crushed Concrete ^{3/}

**MICHIGAN AVENUE IMPROVEMENT PROJECT
(CENTRAL TO KENILWORTH)
VILLAGE OF VILLA PARK**

Use	Mixture	Aggregates Allowed	
HMA High ESAL Low ESAL	C Surface and Binder IL-9.5 or IL-9.5L	<u>Allowed Alone or in Combination</u> ^{5/} : Crushed Gravel Carbonate Crushed Stone ^{2/} Crystalline Crushed Stone Crushed Sandstone Crushed Slag (ACBF) Crushed Steel Slag ^{4/} Crushed Concrete ^{3/}	
	SMA Ndesign 50 Surface		
HMA High ESAL	D Surface and Binder IL-9.5 SMA Ndesign 50 Surface	<u>Allowed Alone or in Combination</u> ^{5/} : Crushed Gravel Carbonate Crushed Stone (other than Limestone) ^{2/} Crystalline Crushed Stone Crushed Sandstone Crushed Slag (ACBF) Crushed Steel Slag ^{4/} Crushed Concrete ^{3/}	
		<u>Other Combinations Allowed:</u>	
		<i>Up to...</i>	<i>With...</i>
		25% Limestone	Dolomite
		50% Limestone	Any Mixture D aggregate other than Dolomite
		75% Limestone	Crushed Slag (ACBF) or Crushed Sandstone
HMA High ESAL	E Surface IL-9.5 SMA Ndesign 80 Surface	<u>Allowed Alone or in Combination</u> ^{5/ 6/} : Crystalline Crushed Stone Crushed Sandstone Crushed Slag (ACBF) Crushed Steel Slag No Limestone.	
		<u>Other Combinations Allowed:</u>	
		<i>Up to...</i>	<i>With...</i>
		50% Dolomite ^{2/}	Any Mixture E aggregate

**MICHIGAN AVENUE IMPROVEMENT PROJECT
(CENTRAL TO KENILWORTH)
VILLAGE OF VILLA PARK**

Use	Mixture	Aggregates Allowed	
		75% Dolomite ^{2/}	Crushed Sandstone, Crushed Slag (ACBF), Crushed Steel Slag, or Crystalline Crushed Stone
		75% Crushed Gravel ^{2/} or Crushed Concrete ^{3/}	Crushed Sandstone, Crystalline Crushed Stone, Crushed Slag (ACBF), or Crushed Steel Slag
HMA High ESAL	F Surface IL-9.5 SMA Ndesign 80 Surface	<u>Allowed Alone or in Combination</u> ^{5/ 6/} :	
		Crystalline Crushed Stone Crushed Sandstone Crushed Slag (ACBF) Crushed Steel Slag No Limestone.	
		<u>Other Combinations Allowed:</u>	
		<i>Up to...</i>	<i>With...</i>
		50% Crushed Gravel ^{2/} , Crushed Concrete ^{3/} , or Dolomite ^{2/}	Crushed Sandstone, Crushed Slag (ACBF), Crushed Steel Slag, or Crystalline Crushed Stone

- 1/ Crushed steel slag allowed in shoulder surface only.
- 2/ Carbonate crushed stone (limestone) and/or crushed gravel shall not be used in SMA Ndesign 80. In SMA Ndesign 50, carbonate crushed stone shall not be blended with any of the other aggregates allowed alone in Ndesign 50 SMA binder or Ndesign 50 SMA surface.
- 3/ Crushed concrete will not be permitted in SMA mixes.
- 4/ Crushed steel slag shall not be used as leveling binder.
- 5/ When combinations of aggregates are used, the blend percent measurements shall be by volume."
- 6/ Combining different types of aggregate will not be permitted in SMA Ndesign 80."

RECLAIMED ASPHALT PAVEMENT AND RECLAIMED ASPHALT SHINGLES (D-1)

Effective: November 1, 2012

Revise: November 1, 2019

**MICHIGAN AVENUE IMPROVEMENT PROJECT
(CENTRAL TO KENILWORTH)
VILLAGE OF VILLA PARK**

Revise Section 1031 of the Standard Specifications to read:

**"SECTION 1031. RECLAIMED ASPHALT PAVEMENT AND RECLAIMED ASPHALT
SHINGLES**

1031.01 Description. Reclaimed asphalt pavement and reclaimed asphalt shingles shall be according to the following.

- (a) Reclaimed Asphalt Pavement (RAP). RAP is the material resulting from cold milling or crushing an existing hot-mix asphalt (HMA) pavement. RAP will be considered processed FRAP after completion of both crushing and screening to size. The Contractor shall supply written documentation that the RAP originated from routes or airfields under federal, state, or local agency jurisdiction.
- (b) Reclaimed Asphalt Shingles (RAS). Reclaimed asphalt shingles (RAS). RAS is from the processing and grinding of preconsumer or post-consumer shingles. RAS shall be a clean and uniform material with a maximum of 0.5 percent unacceptable material, as defined in Central Bureau of Materials Policy Memorandum, "Reclaimed Asphalt Shingle (RAS) Sources", by weight of RAS. All RAS used shall come from a Central Bureau of Materials approved processing facility where it shall be ground and processed to 100 percent passing the 3/8 in. (9.5 mm) sieve and 90 percent passing the #4 (4.75 mm) sieve. RAS shall meet the testing requirements specified herein. In addition, RAS shall meet the following Type 1 or Type 2 requirements.
 - (1) Type 1. Type 1 RAS shall be processed, preconsumer asphalt shingles salvaged from the manufacture of residential asphalt roofing shingles.
 - (2) Type 2. Type 2 RAS shall be processed post-consumer shingles only, salvaged from residential, or four unit or less dwellings not subject to the National Emission Standards for Hazardous Air Pollutants (NESHAP).

1031.02 Stockpiles. RAP and RAS stockpiles shall be according to the following.

- (a) RAP Stockpiles. The Contractor shall construct individual, sealed RAP stockpiles meeting one of the following definitions. Additional processed RAP (FRAP) shall be stockpiled in a separate working pile, as designated in the QC Plan, and only added to the sealed stockpile when test results for the working pile are complete and are found to meet tolerances specified herein for the original sealed FRAP stockpile. Stockpiles shall be sufficiently separated to prevent intermingling at the base. All stockpiles (including unprocessed RAP and FRAP) shall be identified by signs indicating the type as listed below (i.e. "Non- Quality, FRAP -#4 or Type 2 RAS", etc...).
- (1) Fractionated RAP (FRAP). FRAP shall consist of RAP from Class I, HMA (High and Low ESAL) or equivalent mixtures. The coarse aggregate in FRAP shall be crushed aggregate and may represent more than one aggregate type and/or quality, but shall be at least C quality. All FRAP shall be processed prior to testing and sized into fractions with the separation occurring on or between the #4 (4.75 mm) and 1/2 in. (12.5 mm) sieves. Agglomerations shall be minimized such that 100 percent of the

**MICHIGAN AVENUE IMPROVEMENT PROJECT
(CENTRAL TO KENILWORTH)
VILLAGE OF VILLA PARK**

RAP in the coarse fraction shall pass the maximum sieve size specified for the mixture composition of the mix design.

- (2) Restricted FRAP (B quality) stockpiles shall consist of RAP from Class I, HMA (High ESAL), or HMA (High ESAL). If approved by the Engineer, the aggregate from a maximum 3.0 in. (75 mm) single combined pass of surface/binder milling will be classified as B quality. All millings from this application will be processed into FRAP as described previously.
- (3) Conglomerate. Conglomerate RAP stockpiles shall consist of RAP from Class I, HMA (High and Low ESAL) or equivalent mixtures. The coarse aggregate in this RAP shall be crushed aggregate and may represent more than one aggregate type and/or quality, but shall be at least C quality. This RAP may have an inconsistent gradation and/or asphalt binder content prior to processing. All conglomerate RAP shall be processed (FRAP) prior to testing. Conglomerate RAP stockpiles shall not contain steel slag or other expansive material as determined by the Department.
- (4) Conglomerate "D" Quality (DQ). Conglomerate DQ RAP stockpiles shall consist of RAP from HMA shoulders, bituminous stabilized subbases or HMA (Low ESAL)/HMA (Low ESAL) IL-19.0L binder mixture. The coarse aggregate in this RAP may be crushed or round but shall be at least D quality. This RAP may have an inconsistent gradation and/or asphalt binder content. Conglomerate DQ RAP stockpiles shall not contain steel slag or other expansive material as determined by the Department.
- (5) Non-Quality. RAP stockpiles that do not meet the requirements of the stockpile categories listed above shall be classified as "Non-Quality".

RAP or FRAP containing contaminants, such as earth, brick, sand, concrete, sheet asphalt, bituminous surface treatment (i.e. chip seal), pavement fabric, joint sealants, plant cleanout etc., will be unacceptable unless the contaminants are removed to the satisfaction of the Engineer. Sheet asphalt shall be stockpiled separately.

- (b) RAS Stockpiles. Type 1 and Type 2 RAS shall be stockpiled separately and shall be sufficiently separated to prevent intermingling at the base. Each stockpile shall be signed indicating what type of RAS is present.

However, a RAS source may submit a written request to the Department for approval to blend mechanically a specified ratio of Type 1 RAS with Type 2 RAS. The source will not be permitted to change the ratio of the blend without the Department prior written approval. The Engineer's written approval will be required, to mechanically blend RAS with any fine aggregate produced under the AGCS, up to an equal weight of RAS, to improve workability. The fine aggregate shall be "B Quality" or better from an approved Aggregate Gradation Control System source. The fine aggregate shall be one that is approved for use in the HMA mixture and accounted for in the mix design and during HMA production.

Records identifying the shingle processing facility supplying the RAS, RAS type, and lot number shall be maintained by project contract number and kept for a minimum of three years.

**MICHIGAN AVENUE IMPROVEMENT PROJECT
(CENTRAL TO KENILWORTH)
VILLAGE OF VILLA PARK**

1031.03 Testing. FRAP and RAS testing shall be according to the following.

(a) **FRAP Testing.** When used in HMA, the FRAP shall be sampled and tested either during processing or after stockpiling. It shall also be sampled during HMA production.

(1) **During Stockpiling.** For testing during stockpiling, washed extraction samples shall be run at the minimum frequency of one sample per 500 tons (450 metric tons) for the first 2000 tons (1800 metric tons) and one sample per 2000 tons (1800 metric tons) thereafter. A minimum of five tests shall be required for stockpiles less than 4000 tons (3600 metric tons).

(2) **Incoming Material.** For testing as incoming material, washed extraction samples shall be run at a minimum frequency of one sample per 2000 tons (1800 metric tons) or once per week, whichever comes first.

(3) **After Stockpiling.** For testing after stockpiling, the Contractor shall submit a plan for approval to the District proposing a satisfactory method of sampling and testing the RAP/FRAP pile either in-situ or by restockpiling. The sampling plan shall meet the minimum frequency required above and detail the procedure used to obtain representative samples throughout the pile for testing.

Before extraction, each field sample of FRAP, shall be split to obtain two samples of test sample size. One of the two test samples from the final split shall be labeled and stored for Department use. The Contractor shall extract the other test sample according to Department procedure. The Engineer reserves the right to test any sample (split or Department-taken) to verify Contractor test results.

(b) **RAS Testing.** RAS shall be sampled and tested during stockpiling according to Central Bureau of Materials Policy Memorandum, "Reclaimed Asphalt Shingle (RAS) Sources". The Contractor shall also sample as incoming material at the HMA plant.

(1) **During Stockpiling.** Washed extraction and testing for unacceptable materials shall be run at the minimum frequency of one sample per 200 tons (180 metric tons) for the first 1000 tons (900 metric tons) and one sample per 1000 tons (900 metric tons) thereafter. A minimum of five samples are required for stockpiles less than 1000 tons (900 metric tons). Once a ≤ 1000 ton (900 metric ton), five-sample/test stockpile has been established it shall be sealed. Additional incoming RAS shall be in a separate working pile as designated in the Quality Control plan and only added to the sealed stockpile when the test results of the working pile are complete and are found to meet the tolerances specified herein for the original sealed RAS stockpile.

(2) **Incoming Material.** For testing as incoming material at the HMA plant, washed extraction shall be run at the minimum frequency of one sample per 250 tons (227 metric tons). A minimum of five samples are required for stockpiles less than 1000 tons (900 metric tons). The incoming material test results shall meet the tolerances specified herein.

**MICHIGAN AVENUE IMPROVEMENT PROJECT
(CENTRAL TO KENILWORTH)
VILLAGE OF VILLA PARK**

The Contractor shall obtain and make available all test results from start of the initial stockpile sampled and tested at the shingle processing facility in accordance with the facility's QC Plan.

Before extraction, each field sample shall be split to obtain two samples of test sample size. One of the two test samples from the final split shall be labeled and stored for Department use. The Contractor shall extract the other test sample according to Department procedures. The Engineer reserves the right to test any sample (split or Department-taken) to verify Contractor test results.

1031.04 Evaluation of Tests. Evaluation of test results shall be according to the following.

- (a) Evaluation of FRAP Test Results. All test results shall be compiled to include asphalt binder content, gradation and, when applicable (for slag), G_{mm} . A five test average of results from the original pile will be used in the mix designs. Individual extraction test results run thereafter, shall be compared to the average used for the mix design, and will be accepted if within the tolerances listed below.

Parameter	FRAP
No. 4 (4.75 mm)	± 6 %
No. 8 (2.36 mm)	± 5 %
No. 30 (600 μ m)	± 5 %
No. 200 (75 μ m)	± 2.0 %
Asphalt Binder	± 0.3 %
G_{mm}	± 0.03 ^{1/}

- 1/ For stockpile with slag or steel slag present as determined in the current Manual of Test Procedures Appendix B 21, "Determination of Reclaimed Asphalt Pavement Aggregate Bulk Specific Gravity".

If any individual sieve and/or asphalt binder content tests are out of the above tolerances when compared to the average used for the mix design, the FRAP stockpile shall not be used in Hot-Mix Asphalt unless the FRAP representing those tests is removed from the stockpile. All test data and acceptance ranges shall be sent to the District for evaluation.

The Contractor shall maintain a representative moving average of five tests to be used for Hot-Mix Asphalt production.

With the approval of the Engineer, the ignition oven may be substituted for extractions according to the ITP, "Calibration of the Ignition Oven for the Purpose of Characterizing Reclaimed Asphalt Pavement (RAP)" or Illinois Modified AASHTO T-164-11, Test Method A.

- (b) Evaluation of RAS Test Results. All of the test results, with the exception of percent unacceptable materials, shall be compiled and averaged for asphalt binder content and gradation. A five test average of results from the original pile will be used in the mix designs. Individual test results run thereafter, when compared to the average used for the mix design, will be accepted if within the tolerances listed below.

**MICHIGAN AVENUE IMPROVEMENT PROJECT
(CENTRAL TO KENILWORTH)
VILLAGE OF VILLA PARK**

Parameter	RAS
No. 8 (2.36 mm)	± 5 %
No. 16 (1.18 mm)	± 5 %
No. 30 (600 µm)	± 4 %
No. 200 (75 µm)	± 2.5 %
Asphalt Binder Content	± 2.0 %

If any individual sieve and/or asphalt binder content tests are out of the above tolerances when compared to the average used for the mix design, the RAS shall not be used in Hot-Mix Asphalt unless the RAS representing those tests is removed from the stockpile. All test data and acceptance ranges shall be sent to the District for evaluation.

- (c) **Quality Assurance by the Engineer.** The Engineer may witness the sampling and splitting conduct assurance tests on split samples taken by the Contractor for quality control testing a minimum of once a month.

The overall testing frequency will be performed over the entire range of Contractor samples for asphalt binder content and gradation. The Engineer may select any or all split samples for assurance testing. The test results will be made available to the Contractor as soon as they become available.

The Engineer will notify the Contractor of observed deficiencies.

Differences between the Contractor’s and the Engineer’s split sample test results will be considered acceptable if within the following limits.

Test Parameter	Acceptable Limits of Precision	
	FRAP	RAS
% Passing: ^{1/}		
1/2 in.	5.0%	
No. 4	5.0%	
No. 8	3.0%	4.0%
No. 30	2.0%	4.0%
No. 200	2.2%	4.0%
Asphalt Binder Content	0.3%	3.0%
G _{mm}	0.030	

1/ Based on washed extraction.

In the event comparisons are outside the above acceptable limits of precision, the Engineer will immediately investigate.

- (d) **Acceptance by the Engineer.** Acceptable of the material will be based on the validation of the Contractor’s quality control by the assurance process.

1031.05 Quality Designation of Aggregate in RAP and FRAP.

**MICHIGAN AVENUE IMPROVEMENT PROJECT
(CENTRAL TO KENILWORTH)
VILLAGE OF VILLA PARK**

- (a) RAP. The aggregate quality of the RAP for homogeneous, conglomerate, and conglomerate "D" quality stockpiles shall be set by the lowest quality of coarse aggregate in the RAP stockpile and are designated as follows.
- (1) RAP from Class I, HMA (High ESAL), or (Low ESAL) IL-9.5L surface mixtures are designated as containing Class B quality coarse aggregate.
 - (2) RAP from HMA (Low ESAL) IL-19.0L binder mixture is designated as Class D quality coarse aggregate.
 - (3) RAP from Class I, HMA (High ESAL) binder mixtures, bituminous base course mixtures, and bituminous base course widening mixtures are designated as containing Class C quality coarse aggregate.
 - (4) RAP from bituminous stabilized subbase and BAM shoulders are designated as containing Class D quality coarse aggregate.
- (b) FRAP. If the Engineer has documentation of the quality of the FRAP aggregate, the Contractor shall use the assigned quality provided by the Engineer.

If the quality is not known, the quality shall be determined as follows. Fractionated RAP stockpiles containing plus #4 (4.75 mm) sieve coarse aggregate shall have a maximum tonnage of 5,000 tons (4,500 metric tons). The Contractor shall obtain a representative sample witnessed by the Engineer. The sample shall be a minimum of 50 lb (25 kg). The sample shall be extracted according to Illinois Modified AASHTO T 164 by a consultant laboratory prequalified by the Department for the specified testing. The consultant laboratory shall submit the test results along with the recovered aggregate to the District Office. The cost for this testing shall be paid by the Contractor. The District will forward the sample to the Central Bureau of Materials Aggregate Lab for MicroDeval Testing, according to ITP 327. A maximum loss of 15.0 percent will be applied for all HMA applications. The fine aggregate portion of the fractionated RAP shall not be used in any HMA mixtures that require a minimum of "B" quality aggregate or better, until the coarse aggregate fraction has been determined to be acceptable thru a MicroDeval Testing.

1031.06 Use of FRAP and/or RAS in HMA. The use of FRAP and/or RAS shall be the Contractor's option when constructing HMA in all contracts.

- (a) FRAP. The use of FRAP in HMA shall be as follows.
- (1) Coarse Aggregate Size (after extraction). The coarse aggregate in all FRAP shall be equal to or less than the nominal maximum size requirement for the HMA mixture to be produced.
 - (2) Steel Slag Stockpiles. FRAP stockpiles containing steel slag or other expansive material, as determined by the Department, shall be homogeneous and will be approved for use in HMA (High ESAL and Low ESAL) mixtures regardless of lift or mix type.

**MICHIGAN AVENUE IMPROVEMENT PROJECT
(CENTRAL TO KENILWORTH)
VILLAGE OF VILLA PARK**

- (3) Use in HMA Surface Mixtures (High and Low ESAL). FRAP stockpiles for use in HMA surface mixtures (High and Low ESAL) shall have coarse aggregate that is Class B quality or better. FRAP shall be considered equivalent to limestone for frictional considerations unless produced/screened to minus 3/8 inch.
 - (4) Use in HMA Binder Mixtures (High and Low ESAL), HMA Base Course, and HMA Base Course Widening. FRAP stockpiles for use in HMA binder mixtures (High and Low ESAL), HMA base course, and HMA base course widening shall be FRAP in which the coarse aggregate is Class C quality or better.
 - (5) Use in Shoulders and Subbase. FRAP stockpiles for use in HMA shoulders and stabilized subbase (HMA) shall be FRAP, Restricted FRAP, conglomerate, or conglomerate DQ.
- (b) RAS. RAS meeting Type 1 or Type 2 requirements will be permitted in all HMA applications as specified herein.
- (c) FRAP and/or RAS Usage Limits. Type 1 or Type 2 RAS may be used alone or in conjunction with FRAP in HMA mixtures up to a maximum of 5.0 percent by weight of the total mix.

When FRAP is used alone or FRAP is used in conjunction with RAS, the percent of virgin asphalt binder replacement (ABR) shall not exceed the amounts listed below for a given N Design.

Maximum Asphalt Binder Replacement (ABR) for FRAP with RAS Combination

HMA Mixtures <i>1/ 2/ 4/</i>	Maximum % ABR			
	Ndesign	Binder ^{5/}	Surface ^{5/}	Polymer Modified ^{3/}
30L		50	40	30
50		40	35	30
70		40	30	30
90		40	30	30
SMA				30
IL-4.75				40

1/ For Low ESAL HMA shoulder and stabilized subbase, the percent asphalt binder replacement shall not exceed 50 % of the total asphalt binder in the mixture.

2/ When the binder replacement exceeds 15 % for all mixes, except for SMA and IL-4.75, the high and low virgin asphalt binder grades shall each be reduced by one grade (i.e. 25 % binder replacement using a virgin asphalt binder grade of PG64-22 will be reduced to a PG58-28).

**MICHIGAN AVENUE IMPROVEMENT PROJECT
(CENTRAL TO KENILWORTH)
VILLAGE OF VILLA PARK**

When constructing full depth HMA and the ABR is less than 15 %, the required virgin asphalt binder grade shall be PG64-28.

- 3/ When the ABR for SMA or IL-4.75 is 15 % or less, the required virgin asphalt binder shall be SBS PG76-22 and the elastic recovery shall be a minimum of 80. When the ABR for SMA or IL-4.75 exceeds 15%, the virgin asphalt binder grade shall be SBS PG70-28 and the elastic recovery shall be a minimum of 80.
- 4/ When FRAP or RAS is used alone, the maximum percent asphalt binder replacement designated on the table shall be reduced by 10 %.
- 5/ When the mix has Illinois Flexibility Index Test (I-FIT) requirements, the maximum percent asphalt binder replacement designated on the table may be increased by 5%.

1031.07 HMA Mix Designs. At the Contractor's option, HMA mixtures may be constructed utilizing FRAP and/or RAS material meeting the detailed requirements specified herein.

- (a) FRAP and/or RAS. FRAP and /or RAS mix designs shall be submitted for verification. If additional FRAP or RAS stockpiles are tested and found to be within tolerance, as defined under "Evaluation of Tests" herein, and meet all requirements herein, the additional FRAP or RAS stockpiles may be used in the original design at the percent previously verified.
- (b) RAS. Type 1 and Type 2 RAS are not interchangeable in a mix design.

The RAP, FRAP and RAS stone specific gravities (G_{sb}) shall be according to the "Determination of Aggregate Bulk (Dry) Specific Gravity (G_{sb}) of Reclaimed Asphalt Pavement (RAP) and Reclaimed Asphalt Shingles (RAS)" procedure in the Department's Manual of Test Procedures for Materials.

1031.08 HMA Production. HMA production utilizing FRAP and/or RAS shall be as follows.

A scalping screen, gator, crushing unit, or comparable sizing device approved by the Engineer shall be used in the RAS and FRAP feed system to remove or reduce oversized and agglomerated material.

If during mix production, corrective actions fail to maintain FRAP, RAS or QC/QA test results within control tolerances or the requirements listed herein, the Contractor shall cease production of the mixture containing FRAP or RAS and conduct an investigation that may require a new mix design.

- (a) FRAP. The coarse aggregate in all FRAP used shall be equal to or less than the nominal maximum size requirement for the HMA mixture being produced.
- (b) RAS. RAS shall be incorporated into the HMA mixture either by a separate weight depletion system or by using the RAP weigh belt. Either feed system shall be interlocked with the aggregate feed or weigh system to maintain correct proportions for

**MICHIGAN AVENUE IMPROVEMENT PROJECT
(CENTRAL TO KENILWORTH)
VILLAGE OF VILLA PARK**

all rates of production and batch sizes. The portion of RAS shall be controlled accurately to within ± 0.5 percent of the amount of RAS utilized. When using the weight depletion system, flow indicators or sensing devices shall be provided and interlocked with the plant controls such that the mixture production is halted when RAS flow is interrupted.

- (c) HMA Plant Requirements. HMA plants utilizing FRAP and/or RAS shall be capable of automatically recording and printing the following information.

(1) Dryer Drum Plants.

- a. Date, month, year, and time to the nearest minute for each print.
- b. HMA mix number assigned by the Department.
- c. Accumulated weight of dry aggregate (combined or individual) in tons (metric tons) to the nearest 0.1 ton (0.1 metric ton).
- d. Accumulated dry weight of RAS and FRAP in tons (metric tons) to the nearest 0.1 ton (0.1 metric ton).
- e. Accumulated mineral filler in revolutions, tons (metric tons), etc. to the nearest 0.1 unit.
- f. Accumulated asphalt binder in gallons (liters), tons (metric tons), etc. to the nearest 0.1 unit.
- g. Residual asphalt binder in the RAS and FRAP material as a percent of the total mix to the nearest 0.1 percent.
- h. Aggregate RAS and FRAP moisture compensators in percent as set on the control panel. (Required when accumulated or individual aggregate and RAS and FRAP are printed in wet condition.)
- i. When producing mixtures with FRAP and/or RAS, a positive dust control system shall be utilized.
- j. Accumulated mixture tonnage.
- k. Dust Removed (accumulated to the nearest 0.1 ton (0.1 metric ton))

(2) Batch Plants.

- a. Date, month, year, and time to the nearest minute for each print.
- b. HMA mix number assigned by the Department.
- c. Individual virgin aggregate hot bin batch weights to the nearest pound (kilogram).

**MICHIGAN AVENUE IMPROVEMENT PROJECT
(CENTRAL TO KENILWORTH)
VILLAGE OF VILLA PARK**

- d. Mineral filler weight to the nearest pound (kilogram).
- e. RAS and FRAP weight to the nearest pound (kilogram).
- f. Virgin asphalt binder weight to the nearest pound (kilogram).
- g. Residual asphalt binder in the RAS and FRAP material as a percent of the total mix to the nearest 0.1 percent.

The printouts shall be maintained in a file at the plant for a minimum of one year or as directed by the Engineer and shall be made available upon request. The printing system will be inspected by the Engineer prior to production and verified at the beginning of each construction season thereafter.

1031.09 RAP in Aggregate Surface Course and Aggregate Wedge Shoulders, Type B.
The use of RAP in aggregate surface course and aggregate shoulders shall be as follows.

- (a) Stockpiles and Testing. RAP stockpiles may be any of those listed in Article 1031.02, except "Non-Quality" and "FRAP". The testing requirements of Article 1031.03 shall not apply. RAP used shall be according to the current Central Bureau of Materials Policy Memorandum, "Reclaimed Asphalt Pavement (RAP) for Aggregate Applications".
- (b) Gradation. The RAP material shall meet the gradation requirements for CA 6 according to Article 1004.01(c), except the requirements for the minus No. 200 (75 μ m) sieve shall not apply. The sample for the RAP material shall be air dried to constant weight prior to being tested for gradation."

BDE SPECIAL PROVISIONS
For the April 24, 2020 and June 12, 2020 Lettings

The following special provisions indicated by a "check mark" are applicable to this contract and will be included by the Project Coordination and Implementation Section of the BD&E. An * indicates a new or revised special provision for the letting.

File Name	#		Special Provision Title	Effective	Revised
*	80099	1	<input type="checkbox"/> Accessible Pedestrian Signals (APS)	April 1, 2003	April 1, 2020
	80274	2	<input type="checkbox"/> Aggregate Subgrade Improvement	April 1, 2012	April 1, 2016
	80192	3	<input type="checkbox"/> Automated Flagger Assistance Device	Jan. 1, 2008	
	80173	4	<input type="checkbox"/> Bituminous Materials Cost Adjustments	Nov. 2, 2006	Aug. 1, 2017
	80426	5	<input type="checkbox"/> Bituminous Surface Treatment with Fog Seal	Jan. 1, 2020	
	80241	6	<input type="checkbox"/> Bridge Demolition Debris	July 1, 2009	
	50261	7	<input type="checkbox"/> Building Removal-Case I (Non-Friable and Friable Asbestos)	Sept. 1, 1990	April 1, 2010
	50481	8	<input type="checkbox"/> Building Removal-Case II (Non-Friable Asbestos)	Sept. 1, 1990	April 1, 2010
	50491	9	<input type="checkbox"/> Building Removal-Case III (Friable Asbestos)	Sept. 1, 1990	April 1, 2010
	50531	10	<input type="checkbox"/> Building Removal-Case IV (No Asbestos)	Sept. 1, 1990	April 1, 2010
	80425	11	<input type="checkbox"/> Cape Seal	Jan. 1, 2020	
	80384	12	<input checked="" type="checkbox"/> Compensable Delay Costs	June 2, 2017	April 1, 2019
	80198	13	<input type="checkbox"/> Completion Date (via calendar days)	April 1, 2008	
	80199	14	<input type="checkbox"/> Completion Date (via calendar days) Plus Working Days	April 1, 2008	
	80293	15	<input type="checkbox"/> Concrete Box Culverts with Skews > 30 Degrees and Design Fills ≤ 5 Feet	April 1, 2012	July 1, 2016
	80311	16	<input type="checkbox"/> Concrete End Sections for Pipe Culverts	Jan. 1, 2013	April 1, 2016
	80277	17	<input type="checkbox"/> Concrete Mix Design – Department Provided	Jan. 1, 2012	April 1, 2016
	80261	18	<input checked="" type="checkbox"/> Construction Air Quality – Diesel Retrofit	June 1, 2010	Nov. 1, 2014
	80387	19	<input type="checkbox"/> Contrast Preformed Plastic Pavement Marking	Nov. 1, 2017	
	80029	20	<input type="checkbox"/> Disadvantaged Business Enterprise Participation	Sept. 1, 2000	March 2, 2019
	80402	21	<input type="checkbox"/> Disposal Fees	Nov. 1, 2018	
	80378	22	<input type="checkbox"/> Dowel Bar Inserter	Jan. 1, 2017	Jan. 1, 2018
	80405	23	<input type="checkbox"/> Elastomeric Bearings	Jan. 1, 2019	
	80421	24	<input type="checkbox"/> Electric Service Installation	Jan. 1, 2020	
	80415	25	<input type="checkbox"/> Emulsified Asphalts	Aug. 1, 2019	
	80423	26	<input type="checkbox"/> Engineer's Field Office and Laboratory	Jan. 1, 2020	
	80388	27	<input type="checkbox"/> Equipment Parking and Storage	Nov. 1, 2017	
	80229	28	<input type="checkbox"/> Fuel Cost Adjustment	April 1, 2009	Aug. 1, 2017
	80417	29	<input type="checkbox"/> Geotechnical Fabric for Pipe Underdrains and French Drains	Nov. 1, 2019	
	80420	30	<input type="checkbox"/> Geotextile Retaining Walls	Nov. 1, 2019	
	80304	31	<input type="checkbox"/> Grooving for Recessed Pavement Markings	Nov. 1, 2012	Nov. 1, 2017
	80422	32	<input type="checkbox"/> High Tension Cable Median Barrier Reflectors	Jan. 1, 2020	
	80416	33	<input type="checkbox"/> Hot-Mix Asphalt – Binder and Surface Course	July 2, 2019	Nov. 1, 2019
	80398	34	<input type="checkbox"/> Hot-Mix Asphalt – Longitudinal Joint Sealant	Aug. 1, 2018	Nov. 1, 2019
*	80406	35	<input type="checkbox"/> Hot-Mix Asphalt – Mixture Design Verification and Production (Modified for I-FIT Data Collection)	Jan. 1, 2019	Jan. 2, 2020
	80347	36	<input type="checkbox"/> Hot-Mix Asphalt – Pay for Performance Using Percent Within Limits – Jobsite Sampling	Nov. 1, 2014	July 2, 2019
	80383	37	<input type="checkbox"/> Hot-Mix Asphalt – Quality Control for Performance	April 1, 2017	July 2, 2019
	80411	38	<input type="checkbox"/> Luminaires, LED	April 1, 2019	
	80393	39	<input checked="" type="checkbox"/> Manholes, Valve Vaults, and Flat Slab Tops	Jan. 1, 2018	March 1, 2019
	80045	40	<input type="checkbox"/> Material Transfer Device	June 15, 1999	Aug. 1, 2014
	80418	41	<input type="checkbox"/> Mechanically Stabilized Earth Retaining Walls	Nov. 1, 2019	
	80424	42	<input type="checkbox"/> Micro-Surfacing and Slurry Sealing	Jan. 1, 2020	
*	80428	43	<input type="checkbox"/> Mobilization	April 1, 2020	
	80165	44	<input type="checkbox"/> Moisture Cured Urethane Paint System	Nov. 1, 2006	Jan. 1, 2010
	80412	45	<input type="checkbox"/> Obstruction Warning Luminaires, LED	Aug. 1, 2019	
	80349	46	<input type="checkbox"/> Pavement Marking Blackout Tape	Nov. 1, 2014	April 1, 2016

80371	47	<input type="checkbox"/>	Pavement Marking Removal	July 1, 2016	
80389	48	<input checked="" type="checkbox"/>	Portland Cement Concrete	Nov. 1, 2017	
80359	49	<input type="checkbox"/>	Portland Cement Concrete Bridge Deck Curing	April 1, 2015	Nov. 1, 2019
80300	50	<input type="checkbox"/>	Prefomed Plastic Pavement Marking Type D - Inlaid	April 1, 2012	April 1, 2016
34261	51	<input type="checkbox"/>	Railroad Protective Liability Insurance	Dec. 1, 1986	Jan. 1, 2006
80157	52	<input type="checkbox"/>	Railroad Protective Liability Insurance (5 and 10)	Jan. 1, 2006	
* 80306	53	<input type="checkbox"/>	Reclaimed Asphalt Pavement (RAP) and Reclaimed Asphalt Shingles (RAS)	Nov. 1, 2012	Jan. 2, 2020
80407	54	<input type="checkbox"/>	Removal and Disposal of Regulated Substances	Jan. 1, 2019	Jan. 1, 2020
* 80419	55	<input checked="" type="checkbox"/>	Silt Fence, Inlet Filters, Ground Stabilization and Riprap Filter Fabric	Nov. 1, 2019	April 1, 2020
80395	56	<input type="checkbox"/>	Sloped Metal End Section for Pipe Culverts	Jan. 1, 2018	
80340	57	<input type="checkbox"/>	Speed Display Trailer	April 2, 2014	Jan. 1, 2017
80127	58	<input type="checkbox"/>	Steel Cost Adjustment	April 2, 2004	Aug. 1, 2017
80408	59	<input type="checkbox"/>	Steel Plate Beam Guardrail Manufacturing	Jan. 1, 2019	
80413	60	<input type="checkbox"/>	Structural Timber	Aug. 1, 2019	
80397	61	<input type="checkbox"/>	Subcontractor and DBE Payment Reporting	April 2, 2018	
80391	62	<input type="checkbox"/>	Subcontractor Mobilization Payments	Nov. 2, 2017	April 1, 2019
80317	63	<input type="checkbox"/>	Surface Testing of Hot-Mix Asphalt Overlays	Jan. 1, 2013	Aug. 1, 2019
80298	64	<input type="checkbox"/>	Temporary Pavement Marking	April 1, 2012	April 1, 2017
80403	65	<input type="checkbox"/>	Traffic Barrier Terminal, Type 1 Special	Nov. 1, 2018	
80409	66	<input checked="" type="checkbox"/>	Traffic Control Devices - Cones	Jan. 1, 2019	
80410	67	<input type="checkbox"/>	Traffic Spotters	Jan. 1, 2019	
20338	68	<input type="checkbox"/>	Training Special Provisions	Oct. 15, 1975	
80318	69	<input type="checkbox"/>	Traversable Pipe Grate for Concrete End Sections	Jan. 1, 2013	Jan. 1, 2018
* 80429	70	<input type="checkbox"/>	Ultra-Thin Bonded Wearing Course	April 1, 2020	
80288	71	<input checked="" type="checkbox"/>	Warm Mix Asphalt	Jan. 1, 2012	April 1, 2016
80302	72	<input type="checkbox"/>	Weekly DBE Trucking Reports	June 2, 2012	April 2, 2015
* 80414	73	<input type="checkbox"/>	Wood Fence Sight Screen	Aug. 1, 2019	April 1, 2020
* 80427	74	<input type="checkbox"/>	Work Zone Traffic Control Devices	Mar. 2, 2020	
80071	75	<input type="checkbox"/>	Working Days	Jan. 1, 2002	

The following special provisions are in the 2020 Supplemental Specifications and Recurring Special Provisions.

<u>File Name</u>	<u>Special Provision Title</u>	<u>New Location(s)</u>	<u>Effective</u>	<u>Revised</u>
80404	Coarse Aggregate Quality for Micro-Surfacing and Cape Seals	Article 1004.01(b)	Jan. 1, 2019	
80392	Lights on Barricades	Articles 701.16, 701.17(c)(2) & 603.07	Jan. 1, 2018	
80336	Longitudinal Joint and Crack Patching	Check Sheet #36	April 1, 2014	April 1, 2016
80400	Mast Arm Assembly and Pole	Article 1077.03(b)	Aug. 1, 2018	
80394	Metal Flared End Section for Pipe Culverts	Articles 542.07(c) and 542.11	Jan. 1, 2018	April 1, 2018
80390	Payments to Subcontractors	Article 109.11	Nov. 2, 2017	

The following special provisions have been deleted from use.

<u>File Name</u>	<u>Special Provision Title</u>	<u>Effective</u>	<u>Revised</u>
80328	Progress Payments	Nov. 2, 2013	

The following special provisions require additional information from the designer. The additional information needs to be submitted as a separate document. The Project Coordination and Implementation section will then include the information in the applicable special provision.

- Bridge Demolition Debris
- Building Removal - Case I
- Building Removal - Case II
- Building Removal - Case III
- Building Removal-Case IV
- Completion Date
- Completion Date Plus Working Days
- DBE Participation
- Material Transfer Device
- Railroad Protective Liability Insurance
- Training Special Provisions
- Working Days

COMPENSABLE DELAY COSTS (BDE)

Effective: June 2, 2017

Revised: April 1, 2019

Revise Article 107.40(b) of the Standard Specifications to read:

“(b) Compensation. Compensation will not be allowed for delays, inconveniences, or damages sustained by the Contractor from conflicts with facilities not meeting the above definition; or if a conflict with a utility in an unanticipated location does not cause a shutdown of the work or a documentable reduction in the rate of progress exceeding the limits set herein. The provisions of Article 104.03 notwithstanding, compensation for delays caused by a utility in an unanticipated location will be paid according to the provisions of this Article governing minor and major delays or reduced rate of production which are defined as follows.

- (1) Minor Delay. A minor delay occurs when the work in conflict with the utility in an unanticipated location is completely stopped for more than two hours, but not to exceed two weeks.
- (2) Major Delay. A major delay occurs when the work in conflict with the utility in an unanticipated location is completely stopped for more than two weeks.
- (3) Reduced Rate of Production Delay. A reduced rate of production delay occurs when the rate of production on the work in conflict with the utility in an unanticipated location decreases by more than 25 percent and lasts longer than seven calendar days.”

Revise Article 107.40(c) of the Standard Specifications to read:

“(c) Payment. Payment for Minor, Major, and Reduced Rate of Production Delays will be made as follows.

- (1) Minor Delay. Labor idled which cannot be used on other work will be paid for according to Article 109.04(b)(1) and (2) for the time between start of the delay and the minimum remaining hours in the work shift required by the prevailing practice in the area.

Equipment idled which cannot be used on other work, and which is authorized to standby on the project site by the Engineer, will be paid for according to Article 109.04(b)(4).

- (2) Major Delay. Labor will be the same as for a minor delay.

Equipment will be the same as for a minor delay, except Contractor-owned equipment will be limited to two weeks plus the cost of move-out to either the

Contractor's yard or another job and the cost to re-mobilize, whichever is less. Rental equipment may be paid for longer than two weeks provided the Contractor presents adequate support to the Department (including lease agreement) to show retaining equipment on the job is the most economical course to follow and in the public interest.

- (3) Reduced Rate of Production Delay. The Contractor will be compensated for the reduced productivity for labor and equipment time in excess of the 25 percent threshold for that portion of the delay in excess of seven calendar days. Determination of compensation will be in accordance with Article 104.02, except labor and material additives will not be permitted.

Payment for escalated material costs, escalated labor costs, extended project overhead, and extended traffic control will be determined according to Article 109.13."

Revise Article 108.04(b) of the Standard Specifications to read:

"(b) No working day will be charged under the following conditions.

- (1) When adverse weather prevents work on the controlling item.
- (2) When job conditions due to recent weather prevent work on the controlling item.
- (3) When conduct or lack of conduct by the Department or its consultants, representatives, officers, agents, or employees; delay by the Department in making the site available; or delay in furnishing any items required to be furnished to the Contractor by the Department prevents work on the controlling item.
- (4) When delays caused by utility or railroad adjustments prevent work on the controlling item.
- (5) When strikes, lock-outs, extraordinary delays in transportation, or inability to procure critical materials prevent work on the controlling item, as long as these delays are not due to any fault of the Contractor.
- (6) When any condition over which the Contractor has no control prevents work on the controlling item."

Revise Article 109.09(f) of the Standard Specifications to read:

"(f) Basis of Payment. After resolution of a claim in favor of the Contractor, any adjustment in time required for the work will be made according to Section 108. Any adjustment in the costs to be paid will be made for direct labor, direct materials, direct equipment, direct jobsite overhead, direct offsite overhead, and other direct costs allowed by the resolution. Adjustments in costs will not be made for interest charges, loss of anticipated profit, undocumented loss of efficiency, home office overhead and unabsorbed overhead

other than as allowed by Article 109.13, lost opportunity, preparation of claim expenses and other consequential indirect costs regardless of method of calculation.

The above Basis of Payment is an essential element of the contract and the claim cost recovery of the Contractor shall be so limited.”

Add the following to Section 109 of the Standard Specifications.

“109.13 Payment for Contract Delay. Compensation for escalated material costs, escalated labor costs, extended project overhead, and extended traffic control will be allowed when such costs result from a delay meeting the criteria in the following table.

Contract Type	Cause of Delay	Length of Delay
Working Days	Article 108.04(b)(3) or Article 108.04(b)(4)	No working days have been charged for two consecutive weeks.
Completion Date	Article 108.08(b)(1) or Article 108.08(b)(7)	The Contractor has been granted a minimum two week extension of contract time, according to Article 108.08.

Payment for each of the various costs will be according to the following.

- (a) Escalated Material and/or Labor Costs. When the delay causes work, which would have otherwise been completed, to be done after material and/or labor costs have increased, such increases will be paid. Payment for escalated material costs will be limited to the increased costs substantiated by documentation furnished by the Contractor. Payment for escalated labor costs will be limited to those items in Article 109.04(b)(1) and (2), except the 35 percent and 10 percent additives will not be permitted.
- (b) Extended Project Overhead. For the duration of the delay, payment for extended project overhead will be paid as follows.
 - (1) Direct Jobsite and Offsite Overhead. Payment for documented direct jobsite overhead and documented direct offsite overhead, including onsite supervisory and administrative personnel, will be allowed according to the following table.

Original Contract Amount	Supervisory and Administrative Personnel
Up to \$5,000,000	One Project Superintendent
Over \$ 5,000,000 - up to \$25,000,000	One Project Manager, One Project Superintendent or Engineer, and One Clerk
Over \$25,000,000 - up to \$50,000,000	One Project Manager, One Project Superintendent, One Engineer, and

	One Clerk
Over \$50,000,000	One Project Manager, Two Project Superintendents, One Engineer, and One Clerk

(2) Home Office and Unabsorbed Overhead. Payment for home office and unabsorbed overhead will be calculated as 8 percent of the total delay cost.

(c) Extended Traffic Control. Traffic control required for an extended period of time due to the delay will be paid for according to Article 109.04.

When an extended traffic control adjustment is paid under this provision, an adjusted unit price as provided for in Article 701.20(a) for increase or decrease in the value of work by more than ten percent will not be paid.

Upon payment for a contract delay under this provision, the Contractor shall assign subrogation rights to the Department for the Department's efforts of recovery from any other party for monies paid by the Department as a result of any claim under this provision. The Contractor shall fully cooperate with the Department in its efforts to recover from another party any money paid to the Contractor for delay damages under this provision."

CONSTRUCTION AIR QUALITY – DIESEL RETROFIT (BDE)

Effective: June 1, 2010

Revised: November 1, 2014

The reduction of emissions of particulate matter (PM) for off-road equipment shall be accomplished by installing retrofit emission control devices. The term “equipment” refers to diesel fuel powered devices rated at 50 hp and above, to be used on the jobsite in excess of seven calendar days over the course of the construction period on the jobsite (including rental equipment).

Contractor and subcontractor diesel powered off-road equipment assigned to the contract shall be retrofitted using the phased in approach shown below. Equipment that is of a model year older than the year given for that equipment’s respective horsepower range shall be retrofitted:

Effective Dates	Horsepower Range	Model Year
June 1, 2010 ^{1/}	600-749	2002
	750 and up	2006
June 1, 2011 ^{2/}	100-299	2003
	300-599	2001
	600-749	2002
	750 and up	2006
June 1, 2012 ^{2/}	50-99	2004
	100-299	2003
	300-599	2001
	600-749	2002
	750 and up	2006

1/ Effective dates apply to Contractor diesel powered off-road equipment assigned to the contract.

2/ Effective dates apply to Contractor and subcontractor diesel powered off-road equipment assigned to the contract.

The retrofit emission control devices shall achieve a minimum PM emission reduction of 50 percent and shall be:

- a) Included on the U.S. Environmental Protection Agency (USEPA) *Verified Retrofit Technology List* (<http://www.epa.gov/cleandiesel/verification/verif-list.htm>), or verified by the California Air Resources Board (CARB) (<http://www.arb.ca.gov/diesel/verdev/vt/cvt.htm>); or
- b) Retrofitted with a non-verified diesel retrofit emission control device if verified retrofit emission control devices are not available for equipment proposed to be used on the project, and if the Contractor has obtained a performance certification from the retrofit

device manufacturer that the emission control device provides a minimum PM emission reduction of 50 percent.

Note: Large cranes (Crawler mounted cranes) which are responsible for critical lift operations are exempt from installing retrofit emission control devices if such devices adversely affect equipment operation.

Diesel powered off-road equipment with engine ratings of 50 hp and above, which are unable to be retrofitted with verified emission control devices or if performance certifications are not available which will achieve a minimum 50 percent PM reduction, may be granted a waiver by the Department if documentation is provided showing good faith efforts were made by the Contractor to retrofit the equipment.

Construction shall not proceed until the Contractor submits a certified list of the diesel powered off-road equipment that will be used, and as necessary, retrofitted with emission control devices. The list(s) shall include (1) the equipment number, type, make, Contractor/rental company name; and (2) the emission control devices make, model, USEPA or CARB verification number, or performance certification from the retrofit device manufacturer. Equipment reported as fitted with emissions control devices shall be made available to the Engineer for visual inspection of the device installation, prior to being used on the jobsite.

The Contractor shall submit an updated list of retrofitted off-road construction equipment as retrofitted equipment changes or comes on to the jobsite. The addition or deletion of any diesel powered equipment shall be included on the updated list.

If any diesel powered off-road equipment is found to be in non-compliance with any portion of this special provision, the Engineer will issue the Contractor a diesel retrofit deficiency deduction.

Any costs associated with retrofitting any diesel powered off-road equipment with emission control devices shall be considered as included in the contract unit prices bid for the various items of work involved and no additional compensation will be allowed. The Contractor's compliance with this notice and any associated regulations shall not be grounds for a claim.

Diesel Retrofit Deficiency Deduction

When the Engineer determines that a diesel retrofit deficiency exists, a daily monetary deduction will be imposed for each calendar day or fraction thereof the deficiency continues to exist. The calendar day(s) will begin when the time period for correction is exceeded and end with the Engineer's written acceptance of the correction. The daily monetary deduction will be \$1,000.00 for each deficiency identified.

The deficiency will be based on lack of diesel retrofit emissions control.

If a Contractor accumulates three diesel retrofit deficiency deductions for the same piece of equipment in a contract period, the Contractor will be shutdown until the deficiency is corrected.

Such a shutdown will not be grounds for any extension of the contract time, waiver of penalties, or be grounds for any claim.

80261

MANHOLES, VALVE VAULTS, AND FLAT SLAB TOPS (BDE)

Effective: January 1, 2018

Revised: March 1, 2019

Description. In addition to those manufactured according to the current standards included in this contract, manholes, valve vaults, and flat slab tops manufactured prior to March 1, 2019, according to the previous Highway Standards listed below will be accepted on this contract:

Product	Previous Standards		
Precast Manhole Type A, 4' (1.22 m) Diameter	602401-05	602401-04	602401-03
Precast Manhole Type A, 5' (1.52 m) Diameter	602402-01	602402	602401-03
Precast Manhole Type A, 6' (1.83 m) Diameter	602406-09	602406-08	602406-07
Precast Manhole Type A, 7' (2.13 m) Diameter	602411-07	602411-06	602411-05
Precast Manhole Type A, 8' (2.44 m) Diameter	602416-07	602416-06	602416-05
Precast Manhole Type A, 9' (2.74 m) Diameter	602421-07	602421-06	602421-05
Precast Manhole Type A, 10' (3.05 m) Diameter	602426-01	602426	
Precast Valve Vault Type A, 4' (1.22 m) Diameter	602501-04	602501-03	602501-02
Precast Valve Vault Type A, 5' (1.52 m) Diameter	602506-01	602506	602501-02
Precast Reinforced Concrete Flat Slab Top	602601-05	602601-04	

The following revisions to the Standard Specifications shall apply to manholes, valve vaults, and flat slab tops manufactured according to the current standards included in this contract:

Revise Article 602.02(g) of the Standard Specifications to read:

"(g) Structural Steel (Note 4)..... 1006.04

Note 4. All components of the manhole joint splice shall be galvanized according to the requirements of AASHTO M 111 or M 232 as applicable."

Add the following to Article 602.02 of the Standard Specifications:

"(s) Anchor Bolts and Rods (Note 5)..... 1006.09

Note 5. The threaded rods for the manhole joint splice shall be according to the requirements of ASTM F 1554, Grade 55, (Grade 380)."

Revise the second paragraph of Article 1042.10 of the Standard Specifications to read:

"Catch basin Types A, B, C, and D; Manhole Type A; Inlet Types A and B; Drainage Structures Types 1, 2, 3, 4, 5, and 6; Valve Vault Type A; and reinforced concrete flat slab top (Highway Standard 602601) shall be manufactured according to AASHTO M 199 (M 199M), except as shown on the plans. Additionally, catch basins, inlets, and drainage structures shall have a minimum concrete compressive strength of 4500 psi (31,000 kPa) at 28 days and manholes,

valve vaults, and reinforced concrete flat slab tops shall have a minimum concrete compressive strength of 5000 psi (34,500 kPa) at 28 days.”

80393

PORTLAND CEMENT CONCRETE (BDE)

Effective: November 1, 2017

Revise the Air Content % of Class PP Concrete in Table 1 Classes of Concrete and Mix Design Criteria in Article 1020.04 of the Standard Specifications to read:

"TABLE 1. CLASSES OF CONCRETE AND MIX DESIGN CRITERIA		
Class of Conc.	Use	Air Content %
PP	Pavement Patching Bridge Deck Patching (10)	4.0 - 8.0"
	PP-1	
	PP-2	
	PP-3	
	PP-4	
	PP-5	

Revise Note (4) at the end of Table 1 Classes of Concrete and Mix Design Criteria in Article 1020.04 of the Standard Specifications to read:

“(4) For all classes of concrete, the maximum slump may be increased to 7 in (175 mm) when a high range water-reducing admixture is used. For Class SC, the maximum slump may be increased to 8 in. (200 mm). For Class PS, the maximum slump may be increased to 8 1/2 in. (215 mm) if the high range water-reducing admixture is the polycarboxylate type.”

80389

SILT FENCE, INLET FILTERS, GROUND STABILIZATION AND RIPRAP FILTER FABRIC (BDE)

Effective: November 1, 2019
 Revised: April 1, 2020

Revise Article 280.02(m) and add Article 280.02(n) so the Standard Specifications read:

“(m) Above Grade Inlet Filter (Fitted)..... 1081.15(j)
 (n) Above Grade Inlet Filter (Non-Fitted).....1081.15(k)”

Revise the last sentence of the first paragraph in Article 280.04(c) of the Standard Specifications to read:

“The protection shall be constructed with hay or straw bales, silt filter fence, above grade inlet filters (fitted and non-fitted), or inlet filters.

Revise the first sentence of the second paragraph in Article 280.04(c) of the Standard Specifications to read:

“When above grade inlet filters (fitted and non-fitted) are specified, they shall be of sufficient size to completely span and enclose the inlet structure.”

Revise Article 1080.02 of the Standard Specifications to read:

“1080.02 Geotextile Fabric. The fabric for silt filter fence shall consist of woven fabric meeting the requirements of AASHTO M 288 for unsupported silt fence.

The fabric for ground stabilization shall consist of woven yarns or nonwoven filaments of polyolefins or polyesters. Woven fabrics shall be Class 2 and nonwoven fabrics shall be Class 1 according to AASHTO M 288.

The physical properties for silt fence and ground stabilization fabrics shall be according to the following.

PHYSICAL PROPERTIES			
	Silt Fence Woven ^{1/}	Ground Stabilization Woven ^{2/}	Ground Stabilization Nonwoven ^{2/}
Grab Strength, lb (N) ^{3/} ASTM D 4632	123 (550) MD 101 (450) XD	247 (1100) min. ^{4/}	202 (900) min. ^{4/}
Elongation/Grab Strain, % ASTM D 4632 ^{4/}	49 max.	49 max.	50 min.
Trapezoidal Tear Strength, lb (N) ASTM D 4533 ^{4/}	--	90 (400) min.	79 (350) min.

Puncture Strength, lb (N) ASTM D 6241 ^{4/}	--	494 (2200) min.	433 (1925) min.
Apparent Opening Size, Sieve No. (mm) ASTM D 4751 ^{5/}	30 (0.60) max.	40 (0.43) max.	40 (0.43) max.
Permittivity, sec ⁻¹ ASTM D 4491	0.05 min.		
Ultraviolet Stability, % retained strength after 500 hours of exposure ASTM D 4355	70 min.	50 min.	50 min.

- 1/ NTPEP results or manufacturer's certification to meet test requirements.
- 2/ NTPEP results to meet test requirements. Manufacturer shall have public release status and current reports on laboratory results in Test Data of NTPEP's DataMine.
- 3/ MD = Machine direction. XD = Cross-machine direction.
- 4/ Values represent the minimum average roll value (MARV) in the weaker principle direction, MD or XD.
- 5/ Values represent the maximum average roll value."

Revise Article 1080.03 of the Standard Specifications to read:

"1080.03 Filter Fabric. The filter fabric shall consist of woven yarns or nonwoven filaments of polyolefins or polyesters. Woven fabrics shall be Class 3 for riprap gradations RR 4 and RR 5, and Class 2 for RR 6 and RR 7 according to AASHTO M 288. Woven slit film geotextiles (i.e. geotextiles made from yarns of a flat, tape-like character) shall not be permitted. Nonwoven fabrics shall be Class 2 for riprap gradations RR 4 and RR 5, and Class 1 for RR 6 and RR 7 according to AASHTO M 288. After forming, the fabric shall be processed so that the yarns or filaments retain their relative positions with respect to each other. The fabric shall be new and undamaged.

The filter fabric shall be manufactured in widths of not less than 6 ft (2 m). Sheets of fabric may be sewn together with thread of a material meeting the chemical requirements given for the yarns or filaments to form fabric widths as required. The sheets of filter fabric shall be sewn together at the point of manufacture or another approved location.

The filter fabric shall be according to the following.

PHYSICAL PROPERTIES ^{1/}				
	Gradation Nos. RR 4 & RR 5		Gradation Nos. RR 6 & RR 7	
	Woven	Nonwoven	Woven	Nonwoven
Grab Strength, lb (N) ASTM D 4632 ^{2/}	180 (800) min.	157 (700) min.	247 (1100) min.	202 (900) min.
Elongation/Grab Strain, % ASTM D 4632 ^{2/}	49 max.	50 min.	49 max.	50 min.
Trapezoidal Tear Strength, lb (N) ASTM D 4533 ^{2/}	67 (300) min.	56 (250) min.	90 (400) min.	79 (350) min.
Puncture Strength, lb (N) ASTM D 6241 ^{2/}	370 (1650) min.	309 (1375) min.	494 (2200) min.	433 (1925) min.
Ultraviolet Stability, % retained strength after 500 hours of exposure - ASTM D 4355	50 min.			

1/ NTPEP results to meet test requirements. Manufacturer shall have public release status and current reports on laboratory results in Test Data of NTPEP's DataMine.

2/ Values represent the minimum average roll value (MARV) in the weaker principle direction [machine direction (MD) or cross-machine direction (XD)].

As determined by the Engineer, the filter fabric shall meet the requirements noted in the following after an onsite investigation of the soil to be protected.

Soil by Weight (Mass) Passing the No. 200 sieve (75 µm), %	Apparent Opening Size, Sieve No. (mm) - ASTM D 4751 ^{1/}	Permittivity, sec ⁻¹ ASTM D 4491
49 max.	60 (0.25) max.	0.2 min.
50 min.	70 (0.22) max.	0.1 min.

1/ Values represent the maximum average roll value."

Revise Article 1081.15(h)(3)a of the Standard Specifications to read:

"a. Inner Filter Fabric Bag. The inner filter fabric bag shall be constructed of woven yarns or nonwoven filaments made of polyolefins or polyesters with a minimum silt and debris capacity of 2.0 cu ft (0.06 cu m). Woven fabric shall be Class 3 and nonwoven fabric shall be Class 2 according to AASHTO M 288. The fabric bag shall be according to the following.

PHYSICAL PROPERTIES		
	Woven	Nonwoven
Grab Strength, lb (N) ASTM D 4632 ^{1/}	180 (800) min.	157 (700) min.
Elongation/Grab Strain, % ASTM D 4632 ^{1/}	49 max.	50 min.
Trapezoidal Tear Strength, lb (N) ASTM D 4533 ^{1/}	67 (300) min.	56 (250) min.
Puncture Strength, lb (N) ASTM D 6241 ^{1/}	370 (1650) min.	309 (1375) min.
Apparent Opening Size, Sieve No. (mm) ASTM D 4751 ^{2/}	60 (0.25) max.	
Permittivity, sec ⁻¹ ASTM D 4491	2.0 min.	
Ultraviolet Stability, % retained strength after 500 hours of exposure – ASTM D 4355	70 min.	

1/ Values represent the minimum average roll value (MARV) in the weaker principle direction [machine direction (MD) or cross-machine direction (XD)].

2/ Values represent the maximum average roll value.”

Revise Article 1081.15(i)(1) of the Standard Specifications to read:

“(i) Urethane Foam/Geotextile. Urethane foam/geotextile shall be triangular shaped having a minimum height of 10 in. (250 mm) in the center with equal sides and a minimum 20 in. (500 mm) base. The triangular shaped inner material shall be a low density urethane foam. The outer geotextile fabric cover shall consist of woven yarns or nonwoven filaments made of polyolefins or polyesters placed around the inner material and shall extend beyond both sides of the triangle a minimum of 18 in. (450 mm). Woven filter fabric shall be Class 3 and nonwoven filter fabric shall be Class 2 according to AASHTO M 288.

(1) The geotextile shall meet the following properties.

PHYSICAL PROPERTIES		
	Woven	Nonwoven
Grab Strength, lb (N) ASTM D 4632 ^{1/}	180 (800) min.	157 (700) min.
Elongation/Grab Strain, % ASTM D 4632 ^{1/}	49 max.	50 min.
Trapezoidal Tear Strength, lb (N) ASTM D 4533 ^{1/}	67 (300) min.	56 (250) min.
Puncture Strength, lb (N) ASTM D 6241 ^{1/}	370 (1650) min.	309 (1375) min.

Apparent Opening Size, Sieve No. (mm) ASTM D 4751 ^{2/}	30 (0.60) max.
Permittivity, sec ⁻¹ ASTM D 4491	2.0 min.
Ultraviolet Stability, % retained strength after 500 hours of exposure – ASTM D 4355	70 min.

1/ Values represent the minimum average roll value (MARV) in the weaker principle direction [machine direction (MD) or cross-machine direction (XD)].

2/ Values represent the maximum average roll value.”

Add the following to Article 1081.15(i) of the Standard Specifications.

“(3) Certification. The manufacturer shall furnish a certificate with each shipment of urethane foam/geotextile assemblies stating the amount of product furnished and that the material complies with these requirements.”

Revise the title and first sentence of Article 1081.15(j) of the Standards Specifications to read:

“(j) Above Grade Inlet Filters (Fitted). Above grade inlet filters (fitted) shall consist of a rigid polyethylene frame covered with a fitted geotextile filter fabric.”

Revise Article 1081.15(j)(2) of the Standard Specifications to read:

(2) Fitted Geotextile Filter Fabric. The fitted geotextile filter fabric shall consist of woven yarns or nonwoven filaments made of polyolefins or polyesters. Woven filter fabric shall be Class 3 and nonwoven filter fabric shall be Class 2 according to AASHTO M 288. The filter shall be fabricated to provide a direct fit to the frame. The top of the filter shall integrate a coarse screen with a minimum apparent opening size of 1/2 in. (13 mm) to allow large volumes of water to pass through in the event of heavy flows. The filter shall have integrated anti-buoyancy pockets capable of holding a minimum of 3.0 cu ft (0.08 cu m) of stabilization material. Each filter shall have a label with the following information sewn to or otherwise permanently adhered to the outside: manufacturer’s name, product name, and lot, model, or serial number. The fitted geotextile filter fabric shall be according to the table in Article 1081.15(h)(3)a above.”

Add Article 1081.15(k) to the Standard Specifications to read:

“(k) Above Grade Inlet Filters (Non-Fitted). Above grade inlet filters (non-fitted) shall consist of a geotextile fabric surrounding a metal frame. The frame shall consist of either a) a circular cage formed of welded wire mesh, or b) a collapsible aluminum frame, as described below.

(1) Frame Construction.

- a) Welded Wire Mesh Frame. The frame shall consist of 6 in. x 6 in. (150 mm x 150 mm) welded wire mesh formed of #10 gauge (3.42 mm) steel conforming to ASTM A 185. The mesh shall be 30 in. (750 mm) tall and formed into a 42 in. (1.05 m) minimum diameter cylinder.
 - b) Collapsible Aluminum Frame. The collapsible aluminum frame shall consist of grade 6036 aluminum. The frame shall have anchor lugs that attach it to the inlet grate, which shall resist movement from water and debris. The collapsible joints of the frame shall have a locking device to secure the vertical members in place, which shall prevent the frame from collapsing while under load from water and debris.
- (2) Geotextile Fabric. The geotextile fabric shall consist of woven yarns or nonwoven filaments made of polyolefins or polyesters. The woven filter fabric shall be a Class 3 and the nonwoven filter fabric shall be a Class 2 according to AASHTO M 288. The geotextile fabric shall be according to the table in Article 1081.15(h)(3)a above.
- (3) Geotechnical Fabric Attachment to the Frame.
- a) Welded Wire Mesh Frame. The woven or nonwoven geotextile fabric shall be wrapped 3 in. (75 mm) over the top member of a 6 in. x 6 in. (150 mm x 150 mm) welded wire mesh frame and secured with fastening rings constructed of wire conforming to ASTM A 641, A 809, A 370, and A 938 at 6 in. (150 mm) on center. The fastening rings shall penetrate both layers of geotextile and securely close around the steel mesh. The geotextile shall be secured to the sides of the welded wire mesh with fastening rings at a spacing of 1 per sq ft (11 per sq m) and securely close around a steel member.
 - b) Collapsible Aluminum Frame. The woven or nonwoven fabric shall be secured to the aluminum frame along the top and bottom of the frame perimeter with strips of aluminum secured to the perimeter member, such that the anchoring system provides a uniformly distributed stress throughout the geotechnical fabric.
- (4) Certification. The manufacturer shall furnish a certificate with each shipment of above grade inlet filter assemblies stating the amount of product furnished and that the material complies with these requirements.”

TRAFFIC CONTROL DEVICES - CONES (BDE)

Effective: January 1, 2019

Revise Article 701.15(a) of the Standard Specifications to read:

“(a) Cones. Cones are used to channelize traffic. Cones used to channelize traffic at night shall be reflectorized; however, cones shall not be used in nighttime lane closure tapers or nighttime lane shifts.”

Revise Article 1106.02(b) of the Standard Specifications to read:

“(b) Cones. Cones shall be predominantly orange. Cones used at night that are 28 to 36 in. (700 to 900 mm) in height shall have two white circumferential stripes. If non-reflective spaces are left between the stripes, the spaces shall be no more than 2 in. (50mm) in width. Cones used at night that are taller than 36 in. (900 mm) shall have a minimum of two white and two fluorescent orange alternating, circumferential stripes with the top stripe being fluorescent orange. If non-reflective spaces are left between the stripes, the spaces shall be no more than 3 in. (75 mm) in width.

The minimum weights for the various cone heights shall be 4 lb for 18 in. (2 kg for 450 mm), 7 lb for 28 in. (3 kg for 700 mm), and 10 lb for 36 in. (5 kg for 900 mm) with a minimum of 60 percent of the total weight in the base. Cones taller than 36 in. shall be weighted per the manufacturer's specifications such that they are not moved by wind or passing traffic.”

80409

WARM MIX ASPHALT (BDE)

Effective: January 1, 2012

Revised: April 1, 2016

Description. This work shall consist of designing, producing and constructing Warm Mix Asphalt (WMA) in lieu of Hot Mix Asphalt (HMA) at the Contractor's option. Work shall be according to Sections 406, 407, 408, 1030, and 1102 of the Standard Specifications, except as modified herein. In addition, any references to HMA in the Standard Specifications, or the special provisions shall be construed to include WMA.

WMA is an asphalt mixture which can be produced at temperatures lower than allowed for HMA utilizing approved WMA technologies. WMA technologies are defined as the use of additives or processes which allow a reduction in the temperatures at which HMA mixes are produced and placed. WMA is produced by the use of additives, a water foaming process, or combination of both. Additives include minerals, chemicals or organics incorporated into the asphalt binder stream in a dedicated delivery system. The process of foaming injects water into the asphalt binder stream, just prior to incorporation of the asphalt binder with the aggregate.

Approved WMA technologies may also be used in HMA provided all the requirements specified herein, with the exception of temperature, are met. However, asphalt mixtures produced at temperatures in excess of 275 °F (135 °C) will not be considered WMA when determining the grade reduction of the virgin asphalt binder grade.

Equipment.

Revise the first paragraph of Article 1102.01 of the Standard Specifications to read:

"1102.01 Hot-Mix Asphalt Plant. The hot-mix asphalt (HMA) plant shall be the batch-type, continuous-type, or dryer drum plant. The plants shall be evaluated for prequalification rating and approval to produce HMA according to the current Bureau of Materials and Physical Research Policy Memorandum, "Approval of Hot-Mix Asphalt Plants and Equipment". Once approved, the Contractor shall notify the Bureau of Materials and Physical Research to obtain approval of all plant modifications. The plants shall not be used to produce mixtures concurrently for more than one project or for private work unless permission is granted in writing by the Engineer. The plant units shall be so designed, coordinated and operated that they will function properly and produce HMA having uniform temperatures and compositions within the tolerances specified. The plant units shall meet the following requirements."

Add the following to Article 1102.01(a) of the Standard Specifications.

"(11) Equipment for Warm Mix Technologies.

- a. Foaming. Metering equipment for foamed asphalt shall have an accuracy of ± 2 percent of the actual water metered. The foaming control system shall be electronically interfaced with the asphalt binder meter.

- b. Additives. Additives shall be introduced into the plant according to the supplier's recommendations and shall be approved by the Engineer. The system for introducing the WMA additive shall be interlocked with the aggregate feed or weigh system to maintain correct proportions for all rates of production and batch sizes."

Mix Design Verification.

Add the following to Article 1030.04 of the Standard Specifications.

"(e) Warm Mix Technologies.

- (1) Foaming. WMA mix design verification will not be required when foaming technology is used alone (without WMA additives). However, the foaming technology shall only be used on HMA designs previously approved by the Department.
- (2) Additives. WMA mix designs utilizing additives shall be submitted to the Engineer for mix design verification."

Construction Requirements.

Revise the second paragraph of Article 406.06(b)(1) of the Standard Specifications to read:

"The HMA shall be delivered at a temperature of 250 to 350 °F (120 to 175 °C).
WMA shall be delivered at a minimum temperature of 215 °F (102 °C)."

Basis of Payment.

This work will be paid at the contract unit price bid for the HMA pay items involved. Anti-strip will not be paid for separately, but shall be considered as included in the cost of the work.

80288

State of Illinois
Department of Transportation
Bureau of Local Roads and Streets

SPECIAL PROVISION
FOR
BIDDING REQUIREMENTS AND CONDITIONS FOR CONTRACT PROPOSALS

Effective: January 1, 2001

Revised: January 1, 2014

All references to Sections or Articles in this specification shall be construed to mean specific Section or Article of the Standard Specifications for Road and Bridge Construction, adopted by the Department of Transportation.

Replace Article 102.01 of the Standard Specifications with the following:

"Prequalification of Bidders. When prequalification is required and the Awarding Authority for contract construction work is the County Board of a County, the Council, the City Council, or the President and Board of Trustees of a city, village, or town, each prospective bidder, in evidence of competence, shall furnish the Awarding Authority as a prerequisite to the release of proposal forms by the Awarding Authority, a certified or photostatic copy of a "Certificate of Eligibility" issued by the Department of Transportation, according to the Department's "Prequalification Manual".

The two low bidders must file, within 24 hours after the letting, a sworn affidavit in triplicate, showing all uncompleted contracts awarded to them and all low bids pending award for Federal, State, County, Municipal and private work, using the blank form made available for this affidavit. One copy shall be filed with the Awarding Authority and two copies with IDOT's District office.

Issuance of Proposal Forms. The Awarding Authority reserves the right to refuse to issue a proposal form for bidding purposes for any of the following reasons:

- (a) Lack of competency and adequate machinery, plant, and other equipment, as revealed by the financial statement and experience questionnaires required in the prequalification procedures.
- (b) Uncompleted work which, in the judgment of the Awarding Authority, might hinder or prevent the prompt completion of additional work awarded.
- (c) False information provided on a bidder's "Affidavit of Availability".
- (d) Failure to pay, or satisfactorily settle, all bills due for labor and material on former contracts in force at the time of issuance of proposal forms.
- (e) Failure to comply with any prequalification regulations of the Department.
- (f) Default under previous contracts.
- (g) Unsatisfactory performance record as shown by past work for the Awarding Authority, judged from the standpoint of workmanship and progress.
- (h) When the Contractor is suspended from eligibility to bid at a public letting where the contract is awarded by, or requires approval of, the Department.
- (i) When any agent, servant, or employee of the prospective bidder currently serves as a member, employee, or agent of a governmental body that is financially involved in the proposal work.

- (j) When any agent, servant, or employee of the perspective bidder has participated in the preparation of plans or specifications for the proposed work.

Interpretation of Quantities in the Bid Schedule. The quantities appearing in the bid schedule are approximate and are prepared for the comparison of bids. Payment to the Contractor will be made only for the actual quantities of work performed and accepted or materials furnished according to the contract. The scheduled quantities of work to be done and materials to be furnished may be increased, decreased, or omitted as hereinafter provided.

Examination of Plans, Specifications, Special Provisions, and Site of Work. The bidder shall, before submitting a bid, carefully examine the provisions of the contract. The bidder shall inspect in detail the site of the proposed work, investigate and become familiar with all the local conditions affecting the contract and fully acquaint themselves with the detailed requirements of construction. Submission of a bid shall be a conclusive assurance and warranty the bidder has made these examinations and the bidder understands all requirements for the performance of the work. If his/her bid is accepted, the bidder shall be responsible for all errors in the proposal resulting from his/her failure or neglect to comply with these instructions. The Awarding Authority will, in no case, be responsible for any costs, expenses, losses, or change in anticipated profits resulting from such failure or neglect of the bidder to make these examinations.

The bidder shall take no advantage of any error or omission in the proposal and advertised contract. Any prospective bidder, who desires an explanation or interpretation of the plans, specification, or any of the contract documents, shall request such in writing from the Awarding Authority, in sufficient time to allow a written reply by the Awarding Authority that can reach all prospective bidders before the submission of their bids. Any reply given a prospective bidder concerning any of the contract documents, plans, and specifications will be furnished to all prospective bidders in the form determined by the Awarding Authority including, but not limited to, an addendum, if the information is deemed by the Awarding Authority to be necessary in submitting bids or if the Awarding Authority concludes the information would aid competition. Oral explanations, interpretations, or instructions given before the submission of bids unless at a prebid conference will not be binding on the Awarding Authority.

Preparation of the Proposal. Bidders shall submit their proposals on the form furnished by the Awarding Authority. The proposal shall be executed properly, and bids shall be made for all items indicated in the proposal form, except when alternate bids are asked, a bid on more than one alternate for each item is not required, unless otherwise provided. The bidder shall indicate in figures, a unit price for each of the separate items called for in the proposal form; the bidder shall show the products of the respective quantities and unit prices in the column provided for that purpose, and the gross sum shown in the place indicated in the proposal form shall be the summation of said products. All writing shall be with ink or typewriter, except the signature of the bidder which shall be written in ink.

If the proposal is made by an individual, that individual's name and business address shall be shown. If made by a firm or partnership, the name and business address of each member of the firm or partnership shall be shown. If made by a corporation, the proposal shall show the names, titles, and business addresses of the president, corporate secretary and treasurer. The proposal shall be signed by president or someone with authority to execute contracts and attested by the corporate secretary or someone with authority to execute or attest to the execution of contracts.

When prequalification is required, the proposal form shall be submitted by an authorized bidder in the same name and style as shown on the "Contractor's Statement of Experience and Financial Condition" used for prequalification.

Rejection of Proposals. The Awarding Authority reserves the right to reject any proposal for any of the conditions in "Issuance of Proposal Forms" or for any of the following reasons:

- (a) More than one proposal for the same work from an individual, firm, partnership, or corporation under the same name or different names.
- (b) Evidence of collusion among bidders.
- (c) Unbalanced proposals in which the bid prices for some items are, in the judgment of the Awarding Authority, out of proportion to the bid prices for other items.
- (d) If the proposal does not contain a unit price for each pay item listed, except in the case of authorized alternate pay items or lump sum pay items.
- (e) If the proposal form is other than that furnished by the Awarding Authority; or if the form is altered or any part thereof is detached.
- (f) If there are omissions, erasures, alterations, unauthorized additions, conditional or alternate bids, or irregularities of any kind which may tend to make the proposal incomplete, indefinite or ambiguous as to its meaning.
- (g) If the bidder adds any provisions reserving the right to accept or reject an award, or to enter into a contract pursuant to an award.
- (h) If the proposal is not accompanied by the proper proposal guaranty.
- (i) If the proposal is prepared with other than ink or typewriter, or otherwise fails to meet the requirements of the above "Preparation of Proposal" section.

Proposal Guaranty. Each proposal shall be accompanied by a bid bond on the Department form contained in the proposal, executed by a corporate surety company satisfactory to the Awarding Authority, by a bank cashier's check or a properly certified check for not less than five percent of the amount bid, or for the amount specified in the following schedule:

<u>Amount Bid</u>		<u>Proposal Guaranty</u>
Up to	\$5,000	\$150
>\$5,000	\$10,000	\$300
>\$10,000	\$50,000	\$1,000
>\$50,000	\$100,000	\$3,000
>\$100,000	\$150,000	\$5,000
>\$150,000	\$250,000	\$7,500
>\$250,000	\$500,000	\$12,500
>\$500,000	\$1,000,000	\$25,000
>\$1,000,000	\$1,500,000	\$50,000
>\$1,500,000	\$2,000,000	\$75,000
>\$2,000,000	\$3,000,000	\$100,000
>\$3,000,000	\$5,000,000	\$150,000
>\$5,000,000	\$7,500,000	\$250,000
>\$7,500,000	\$10,000,000	\$400,000
>\$10,000,000	\$15,000,000	\$500,000
>\$15,000,000	\$20,000,000	\$600,000
>\$20,000,000	\$25,000,000	\$700,000
>\$25,000,000	\$30,000,000	\$800,000
>\$30,000,000	\$35,000,000	\$900,000
Over	\$35,000,000	\$1,000,000

In the event that one proposal guaranty check is intended to cover two or more proposals, the amount must equal to the sum of the proposal guaranties which would be required for each individual proposal.

Bank cashier's checks or properly certified checks accompanying proposals shall be made payable to the County Treasurer, when a County is the Awarding Authority; or the City, Village, or Town Treasurer, when a city, village, or town is the Awarding Authority.

The proposal guaranty checks of all, except the two lowest responsible, will be returned promptly after the proposals have been checked, tabulated, and the relation of the proposals established. Proposal guaranty checks of the two lowest bidders will be returned as soon as the contract and contract bond of the successful bidder have been properly executed and approved. Bid bonds will not be returned.

After a period of three working days has elapsed after the date of opening proposals, the Awarding Authority may permit the two lowest bidders to substitute for the bank cashier's checks or certified checks submitted with their proposals as proposal guaranties, bid bonds on the Department forms executed by corporate surety companies satisfactory to the Awarding Authority.

Delivery of Proposals. If a special envelope is supplied by the Awarding Authority, each proposal should be submitted in that envelope furnished by the Awarding Authority and the blank spaces on the envelope shall be filled in correctly to clearly indicate its contents. When an envelope other than the special one furnished by the Awarding Authority is used, it shall be marked to clearly indicate its contents. When sent by mail, the sealed proposal shall be addressed to the Awarding Authority at the address and in care of the official in whose office the bids are to be received. All proposals shall be filed prior to the time and at the place specified in the Notice to Bidders. Proposals received after the time specified will be returned to the bidder unopened.

Withdrawal of Proposals. Permission will be given a bidder to withdraw a proposal if the bidder makes the request in writing or in person before the time for opening proposals.

Public Opening of Proposals. Proposals will be opened and read publicly at the time and place specified in the Notice to Bidders. Bidders, their authorized agents, and other interested parties are invited to be present.

Consideration of Proposals. After the proposals are opened and read, they will be compared on the basis of the summation of the products of the quantities shown in the bid schedule by the unit bid prices. In awarding contracts, the Awarding Authority will, in addition to considering the amounts stated in the proposals, take into consideration the responsibility of the various bidders as determined from a study of the data required under "Prequalification of Bidders", and from other investigations which it may elect to make.

The right is reserved to reject any or all proposals, to waive technicalities, or to advertise for new proposals, if in the judgment of the Awarding Authority, the best interests of the Awarding Authority will be promoted thereby.

Award of Contract. The award of contract will be made within 45 calendar days after the opening of proposals to the lowest responsible and qualified bidder whose proposal complies with all the requirements prescribed. The successful bidder will be notified by letter of intent that his/her bid has been accepted, and subject to the following conditions, the bidder will be the Contractor.

An approved contract executed by the Awarding Authority is required before the Awarding Authority is bound. An award may be cancelled any time by the Awarding Authority prior to execution in order to protect the public interest and integrity of the bidding process or for any other reason if, in the judgment of the Awarding Authority, the best interests of the Awarding Authority will be promoted thereby.

If a contract is not awarded within 45 days after the opening of proposals, bidders may file a written request with the Awarding Authority for the withdrawal of their bid, and the Awarding Authority will permit such withdrawal.

Requirement of Contract Bond. If the Awarding Authority requires a Contract Bond, the Contractor or Supplier shall furnish the Awarding Authority a performance and payment bond with good and sufficient sureties in the full amount of the award as the penal sum. The surety shall be acceptable to the Awarding Authority, shall waive notice of any changes and extensions of time, and shall submit its bond on the form furnished by the Awarding Authority.

Execution of Contract. The contract shall be executed by the successful bidder and returned, together with the Contract Bond, within 15 days after the contract has been mailed to the bidder.

If the bidder to whom the award is made is a corporation organized under the laws of a State other than Illinois, the bidder shall furnish the Awarding Authority a copy of the corporation's Certificate of Authority to do business in the State of Illinois with the return of the executed contract and bond. Failure to furnish such evidence of a Certificate of Authority within the time required will be considered as just cause for the annulment of the award and the forfeiture of the proposal guaranty to the Awarding Authority, not as a penalty, but in payment of liquidated damages sustained as a result of such failure.

Failure to Execute Contract. If the contract is not executed by the Awarding Authority within 15 days following receipt from the bidder of the properly executed contracts and bonds, the bidder shall have the right to withdraw his/her bid without penalty.

Failure of the successful bidder to execute the contract and file acceptable bonds within 15 days after the contract has been mailed to the bidder shall be just cause for the cancellation of the award and the forfeiture of the proposal guaranty which shall become the property of the Awarding Authority, not as penalty, but in liquidation of damages sustained. Award may then be made to the next lowest responsible bidder, or the work may be readvertised and constructed under contract, or otherwise, as the Awarding Authority may decide."

State of Illinois
Department of Transportation
Bureau of Local Roads and Streets

SPECIAL PROVISION
FOR
COOPERATION WITH UTILITIES

Effective: January 1, 1999
Revised: January 1, 2007

All references to Sections or Articles in this specification shall be construed to mean specific Section or Article of the Standard Specifications for Road and Bridge Construction, adopted by the Department of Transportation.

Replace Article 105.07 of the Standard Specifications with the following:

"105.07 Cooperation with Utilities. The adjustment of utilities consists of the relocation, removal, replacement, rearrangements, reconstruction, improvement, disconnection, connection, shifting, new installation or altering of an existing utility facility in any manner.

When the plans or special provisions include information pertaining to the location of underground utility facilities, such information represents only the opinion of the Department as to the location of such utilities and is only included for the convenience of the bidder. The Department assumes no responsibility in respect to the sufficiency or the accuracy of the information shown on the plans relative to the location of the underground utility facilities.

Utilities which are to be adjusted shall be adjusted by the utility owner or the owner's representative or by the Contractor as a contract item. Generally, arrangements for adjusting existing utilities will be made by the Department prior to project construction; however, utilities will not necessarily be adjusted in advance of project construction and, in some cases, utilities will not be removed from the proposed construction limits. When utility adjustments must be performed in conjunction with construction, the utility adjustment work will be shown on the plans and/or covered by Special Provisions.

When the Contractor discovers a utility has not been adjusted by the owner or the owner's representative as indicated in the contract documents, or the utility is not shown on the plans or described in the Special Provisions as to be adjusted in conjunction with construction, the Contractor shall not interfere with said utility, and shall take proper precautions to prevent damage or interruption of the utility and shall promptly notify the Engineer of the nature and location of said utility.

All necessary adjustments, as determined by the Engineer, of utilities not shown on the plans or not identified by markers, will be made at no cost to the Contractor except traffic structures, light poles, etc., that are normally located within the proposed construction limits as hereinafter defined will not be adjusted unless required by the proposed improvement.

(a) Limits of Proposed Construction for Utilities Paralleling the Roadway. For the purpose of this Article, limits of proposed construction for utilities extending in the same longitudinal direction as the roadway, shall be defined as follows:

(1) The horizontal limits shall be a vertical plane, outside of, parallel to, and 600 mm (2 ft) distant at right angles from the plan or revised slope limits.

In cases where the limits of excavation for structures are not shown on the plans, the horizontal limits shall be a vertical plane 1.2 m (4 ft) outside the edges of structure footings or the structure where no footings are required.

(2) The upper vertical limits shall be the regulations governing the roadbed clearance for the specific utility involved.

(3) The lower vertical limits shall be the top of the utility at the depth below the proposed grade as prescribed by the governing agency or the limits of excavation, whichever is less.

(b) Limits of Proposed Construction for Utilities Crossing the Roadway. For the purpose of this Article, limits of proposed construction for utilities crossing the roadway in a generally transverse direction shall be defined as follows:

(1) Utilities crossing excavations for structures that are normally made by trenching such as sewers, underdrains, etc. and all minor structures such as manholes, inlets, foundations for signs, foundations for traffic signals, etc., the limits shall be the space to be occupied by the proposed permanent construction unless otherwise required by the regulations governing the specific utility involved.

(2) For utilities crossing the proposed site of major structures such as bridges, sign trusses, etc., the limits shall be as defined above for utilities extending in the same general direction as the roadway.

The Contractor may make arrangements for adjustment of utilities outside of the limits of proposed construction provided the Contractor furnishes the Department with a signed agreement with the utility owner covering the adjustments to be made. The cost of any adjustments made outside the limits of proposed construction shall be the responsibility of the Contractor unless otherwise provided.

The Contractor shall request all utility owners to field locate their facilities according to Article 107.31. The Engineer may make the request for location from the utility after receipt of notice from the Contractor. On request, the Engineer will make an inspection to verify that the utility company has field located its facilities, but will not assume responsibility for the accuracy of such work. The Contractor shall be responsible for maintaining the excavations or markers provided by the utility owners. This field location procedure may be waived if the utility owner has stated in writing to the Department it is satisfied the construction plans are sufficiently accurate. If the utility owner does not submit such statement to the Department, and they do not field locate their facilities in both horizontal and vertical alignment, the Engineer will authorize the Contractor in writing to proceed to locate the facilities in the most economical and reasonable manner, subject to the approval of the Engineer, and be paid according to Article 109.04.

The Contractor shall coordinate with any planned utility adjustment or new installation and the Contractor shall take all precautions to prevent disturbance or damage to utility facilities. Any failure on the part of the utility owner, or their representative, to proceed with any planned utility adjustment or new installation shall be reported promptly by the Contractor to the Engineer orally and in writing.

The Contractor shall take all necessary precautions for the protection of the utility facilities. The Contractor shall be responsible for any damage or destruction of utility facilities resulting from neglect, misconduct, or omission in the Contractor's manner or method of execution or nonexecution of the work, or caused by defective work or the use of unsatisfactory materials. Whenever any damage or destruction of a utility facility occurs as a result of work performed by the Contractor, the utility company will be immediately notified. The utility company will make arrangements to restore such facility to a condition equal to that existing before any such damage or destruction was done.

It is understood and agreed that the Contractor has considered in the bid all of the permanent and temporary utilities in their present and/or adjusted positions.

No additional compensation will be allowed for any delays, inconvenience, or damage sustained by the Contractor due to any interference from the said utility facilities or the operation of relocating the said utility facilities.

State of Illinois
Department of Transportation
Bureau of Local Roads and Streets

SPECIAL PROVISION
FOR
INSURANCE

Effective: February 1, 2007
Revised: August 1, 2007

All references to Sections or Articles in this specification shall be construed to mean specific Section or Article of the Standard Specifications for Road and Bridge Construction, adopted by the Department of Transportation.

The Contractor shall name the following entities as additional insured under the Contractor's general liability insurance policy in accordance with Article 107.27:

Village of Villa Park

Strand Associates, Inc.

The entities listed above and their officers, employees, and agents shall be indemnified and held harmless in accordance with Article 107.26.

State of Illinois
DEPARTMENT OF TRANSPORTATION
Bureau of Local Roads & StreetsSPECIAL PROVISION
FOR
WAGES OF EMPLOYEES ON PUBLIC WORKS

Effective: January 1, 1999

Revised: January 1, 2014

1. **Prevailing Wages.** All wages paid by the Contractor and each subcontractor shall be in compliance with The Prevailing Wage Act (820 ILCS 130), as amended, except where a prevailing wage violates a federal law, order, or ruling, the rate conforming to the federal law, order, or ruling shall govern. The Illinois Department of Labor publishes the prevailing wage rates on its website at www.state.il.us/agency/idol/rates/rates.htm. If the Illinois Department of Labor revises the prevailing wage rates, the revised prevailing wage rates on the Illinois Department of Labor's website shall apply to this contract and the Contractor will not be allowed additional compensation on account of said revisions. The Contractor shall review the wage rates applicable to the work of the contract at regular intervals in order to ensure the timely payment of current wage rates. The Contractor agrees that no additional notice is required. The Contractor shall be responsible to notify each subcontractor of the wage rates set forth in this contract and any revisions thereto.
2. **Payroll Records.** The Contractor and each subcontractor shall make and keep, for a period of not less than five years from the date of the last payment on a contract or subcontract, records of all laborers, mechanics, and other workers employed by them on the project; the records shall include information required by 820 ILCS 130/5 for each worker. Upon seven business days' notice, the Contractor and each subcontractor shall make available for inspection and copying at a location within this State during reasonable hours, the payroll records to the public body in charge of the project, its officers and agents, the Director of Labor and his deputies and agents, and to federal, State, or local law enforcement agencies and prosecutors.
3. **Submission of Payroll Records.** The Contractor and each subcontractor shall, no later than the 15th day of each calendar month, file a certified payroll for the immediately preceding month with the public body in charge of the project, except that the full social security number and home address shall not be included on weekly transmittals. Instead the payrolls shall include an identification number for each employee (e.g., the last four digits of the employee's social security number). The certified payroll shall consist of a complete copy of the payroll records except starting and ending times of work each day may be omitted

The certified payroll shall be accompanied by a statement signed by the Contractor or subcontractor or an officer, employee, or agent of the contractor or subcontractor which avers that: (i) he or she has examined the certified payroll records required to be submitted by the Act and such records are true and accurate; (ii) the hourly rate paid to each worker is not less than the general prevailing rate of hourly wages required; and (iii) the Contractor or subcontractor is aware that filing a certified payroll that he or she knows to be false is a Class A misdemeanor.
4. **Employees Interviews.** The Contractor and each subcontractor shall permit his/her employees to be interviewed on the job, during working hours, by compliance investigators of the Department or the Department of Labor.

State of Illinois
Department of Transportation
Bureau of Local Roads and Streets

**SPECIAL PROVISION
FOR
EQUIPMENT RENTAL RATES**

Effective: January 1, 2012

All references to Sections or Articles in this specification shall be construed to mean a specific Section or Article of the Standard Specifications for Road and Bridge Construction, adopted by the Department of Transportation.

Replace Article 109.04(b)(4) with the following:

- "(4) Equipment. For any machinery or special equipment (other than small tools) the use of which has been authorized by the Engineer, the Contractor will be paid according to the latest revision of "SCHEDULE OF AVERAGE ANNUAL EQUIPMENT OWNERSHIP EXPENSE" and latest index factor as issued by the Illinois Department of Transportation. The equipment should be of a type and size reasonably required to complete the extra work."

ABV	ABOVE	CU YD	CUBIC YARD	HD	HEAD	PED	PEDESTAL	STD	STANDARD
A/C	ACCESS CONTROL	CULV	CULVERT	HDW	HEADWALL	PNT	POINT	SBI	STATE BOND ISSUE
AC	ACRE	C&G	CURB & GUTTER	HDUTY	HEAVY DUTY	PC	POINT OF CURVATURE	SR	STATE ROUTE
ADJ	ADJUST	D	DEGREE OF CURVE	ha	HECTARE	PI	POINT OF INTERSECTION OF HORIZONTAL CURVE	STA	STATION
AS	AERIAL SURVEYS	DC	DEPRESSED CURVE	HMA	HOT MIX ASPHALT	PRC	POINT OF REVERSE CURVE	SPBGR	STEEL PLATE BEAM GUARDRAIL
AGG	AGGREGATE	DET	DETECTOR	HWY	HIGHWAY	PT	POINT OF TANGENCY	SS	STORM SEWER
AH	AHEAD	DIA	DIAMETER	HORIZ	HORIZONTAL	POT	POINT ON TANGENT	STY	STORY
APT	APARTMENT	DIST	DISTRICT	HSE	HOUSE	POLYETH	POLYETHYLENE	ST	STREET
ASPH	ASPHALT	DOM	DOMESTIC	IL	ILLINOIS	PCC	PORTLAND CEMENT CONCRETE	STR	STRUCTURE
AUX	AUXILIARY	DBL	DOUBLE	IMP	IMPROVEMENT	PP	POWER POLE OR PRINCIPAL POINT	e	S.E. RUN. SUPERELEVATION RATE
AGS	AUXILIARY GAS VALVE (SERVICE)	DSEL	DOWNSTEAM ELEVATION	IN DIA	INCH DIAMETER	PRM	PRIME	SURF	SURFACE
AVE	AVENUE	DSFL	DOWNSTEAM FLOWLINE	INL	INLET	PE	PRIVATE ENTRANCE	SMK	SURVEY MARKER
AX	AXIS OF ROTATION	DR	DRAINAGE OR DRIVE	INST	INSTALLATION	PROF	PROFILE	T	TANGENT DISTANCE
BK	BACK	DJ	DRAINAGE INLET OR DROP INLET	IDS	INTERSECTION DESIGN STUDY	PGL	PROFILE GRADELINE	T.R.	TANGENT RUNOUT DISTANCE
B-B	BACK TO BACK	DRV	DRIVEWAY	INV	INVERT	PROJ	PROJECT	TEL	TELEPHONE
BKPL	BACKPLATE	DCT	DUCT	IP	IRON PIPE	P.C.	PROPERTY CORNER	TB	TELEPHONE BOX
B	BARN	EA	EACH	IR	IRON ROD	PL	PROPERTY LINE	TP	TELEPHONE POLE
BARR	BARRICADE	EB	EASTBOUND	JT	JOINT	PR	PROPOSED	TEMP	TEMPORARY
BGN	BEGIN	EOP	EDGE OF PAVEMENT	kg	KILOGRAM	R	RADIUS	TBM	TEMPORARY BENCH MARK
BM	BENCHMARK	E-CL	EDGE TO CENTERLINE	km	KILOMETER	RR	RAILROAD	TD	TILE DRAIN
BIND	BINDER	E-E	EDGE TO EDGE	LS	LANDSCAPING	RRS	RAILROAD SPIKE	TBE	TO BE EXTENDED
BIT	BITUMINOUS	EL	ELEVATION	LN	LANE	RPS	REFERENCE POINT STAKE	TBR	TO BE REMOVED
BTM	BOTTOM	ENTR	ENTRANCE	LT	LEFT	REF	REFLECTIVE	TBS	TO BE SAVED
BLVD	BOULEVARD	EXC	EXCAVATION	LP	LIGHT POLE	RCCP	REINFORCED CONCRETE CULVERT PIPE	TBP	TOWNSHIP
BRK	BRICK	EX	EXISTING	LG	LIGHTING	REINF	REINFORCEMENT	TR	TOWNSHIP ROAD
BBOX	BUFFALO BOX	EXPWAY	EXPRESSWAY	LF	LINEAL FEET OR LINEAR FEET	REM	REMOVAL	TS	TRAFFIC SIGNAL
BLDG	BUILDING	E	EXTERNAL DISTANCE OF HORIZONTAL CURVE	L	LITER OR CURVE LENGTH	RC	REMOVE CROWN	TSCB	TRAFFIC SIGNAL CONTROL BOX
CIP	CAST IRON PIPE	E	OFFSET DISTANCE TO VERTICAL CURVE	LC	LONG CHORD	REP	REPLACEMENT	TSC	TRAFFIC SYSTEMS CENTER
CB	CATCH BASIN	F-F	FACE TO FACE	LNG	LONGITUDINAL	REST	RESTAURANT	TRVS	TRANSVERSE
C-C	CENTER TO CENTER	FA	FEDERAL AID	L SUM	LUMP SUM	RESURF	RESURFACING	TRVL	TRAVEL
CL	CENTERLINE OR CLEARANCE	FAI	FEDERAL AID INTERSTATE	MACH	MACHINE	RET	RETAINING	TRN	TURN
CL-E	CENTERLINE TO EDGE	FAP	FEDERAL AID PRIMARY	MH	MANHOLE	RT	RIGHT	TY	TYPE
CL-F	CENTERLINE TO FACE	FAS	FEDERAL AID SECONDARY	MATL	MATERIAL	RQW	RIGHT-OF-WAY	T-A	TYPE A
CTS	CENTERS	FAUS	FEDERAL AID URBAN SECONDARY	MED	MEDIAN	RD	ROAD	TYP	TYPICAL
CERT	CERTIFIED	FP	FENCE POST	m	METER	RDWY	ROADWAY	UNDGND	UNDERGROUND
CHSLD	CHISELED	FE	FIELD ENTRANCE	METH	METHOD	ROUTE	ROUTE	USGS	U.S. GEOLOGICAL SURVEY
CS	CITY STREET	FH	FIRE HYDRANT	M	MID-ORDINATE	SAN	SANITARY	USEL	UPSTREAM ELEVATION
CP	CLAY PIPE	FL	FLOW LINE	mm	MILLIMETER	SANS	SANITARY SEWER	USFL	UPSTREAM FLOWLINE
CLSD	CLOSED	FB	FOOT BRIDGE	mm DIA	MILLIMETER DIAMETER	SEC	SECTION	UTIL	UTILITY
CLID	CLOSED LID	FDN	FOUNDATION	MIX	MIXTURE	SEED	SEEDING	VBOX	VALVE BOX
CT	COAT OR COURT	FR	FRAME	F&G	FRAME & GRATE	SHAP	SHAPING	VV	VALVE VAULT
COMB	COMBINATION	FRWAY	FREEWAY	GAL	GALLON	S	SHED	VL	VAULT
C	COMMERCIAL BUILDING	GAL	GALLON	GALV	GALVANIZED	SH	SHEET	VEH	VEHICLE
CE	COMMERCIAL ENTRANCE	G	GARAGE	G	GAS METER	SHLD	SHOULDER	VP	VENT PIPE
CONC	CONCRETE	GM	GAS METER	N & BC	NAIL & BOTTLE CAP	SW	SIDEWALK OR SOUTHWEST	VERT	VERTICAL
CONST	CONSTRUCT	GV	GAS VALVE	N & C	NAIL & CAP	SIG	SIGNAL	VC	VERTICAL CURVE
CONTD	CONTINUED	GRAN	GRANULAR	N & W	NAIL & WASHER	SOD	SODDING	VPC	VERTICAL POINT OF CURVATURE
CONT	CONTINUOUS	GR	GRATE	NDAA	NATIONAL OCEANIC ATMOSPHERIC ADMINISTRATION	SM	SOLID MEDIUM	VPI	VERTICAL POINT OF INTERSECTION
COR	CORNER	GRVL	GRAVEL	NC	NORMAL CROWN	SB	SOUTHBOUND	VPT	VERTICAL POINT OF TANGENCY
CORR	CORRUGATED	GND	GROUND	NB	NORTHBOUND	SE	SOUTHEAST	WM	WATER METER
CMP	CORRUGATED METAL PIPE	GUT	GUTTER	NE	NORTHEAST	SPL	SPECIAL	WV	WATER VALVE
CNTY	COUNTY	GP	GUY POLE	NW	NORTHWEST	SD	SPECIAL DITCH	WMAIN	WATER MAIN
CH	COUNTY HIGHWAY	GW	GUY WIRE	OLID	OPEN LID	SQ FT	SQUARE FEET	WB	WESTBOUND
CSE	COURSE	HH	HANDHOLE	PAT	PATTERN	m²	SQUARE METER	WLDLFL	WILDFLOWERS
XSECT	CROSS SECTION	HATCH	HATCHING	PVD	PAVED	mm²	SQUARE MILLIMETER	W	WITH
m³	CUBIC METER			PVMT	PAVEMENT	SQ YD	SQUARE YARD	WO	WITHOUT
mm³	CUBIC MILLIMETER			PM	PAVEMENT MARKING	STB	STABILIZED		

Illinois Department of Transportation

ISSUED 1-1-97

PASSED: *[Signature]* January 1, 2019
 ENGINEER OF POLICY AND PROCEDURES

APPROVED: *[Signature]* January 1, 2019
 ENGINEER OF DESIGN AND ENVIRONMENT

DATE	REVISIONS
1-1-19	Added new symbols.
1-1-11	Updated abbreviations and symbols.

STANDARD SYMBOLS ABBREVIATIONS AND PATTERNS

(Sheet 1 of 9)

STANDARD 000001-07

<u>ADJUSTMENT ITEMS</u>		<u>EX</u>	<u>PR</u>	<u>ALIGNMENT ITEMS</u>		<u>EX</u>	<u>PR</u>	<u>DRAINAGE ITEMS</u>		<u>EX</u>	<u>PR</u>
Structure To Be Adjusted				Baseline				Channel or Stream Line			
Structure To Be Cleaned				Centerline				Culvert Line			
Main Structure To Be Filled				Centerline Break Circle				Grading & Shaping Ditches			
Structure To Be Filled				Baseline Symbol				Drainage Boundary Line			
Structure To Be Filled Special				Centerline Symbol				Paved Ditch			
Structure To Be Removed				PI Indicator				Aggregate Ditch			
Structure To Be Reconstructed				Point Indicator				Pipe Underdrain			
Structure To Be Reconstructed Special				Horizontal Curve Data (Half Size)		CURVE P.I. STA= ΔP= D= R= T= L= E= g= T.R.= S.E. RUN= P.C. STA= P.T. STA=	CURVE P.I. STA= ΔP= D= R= T= L= E= g= T.R.= S.E. RUN= P.C. STA= P.T. STA=	Storm Sewer			
Frame and Grate To Be Adjusted				<u>BOUNDARIES ITEMS</u>		<u>EX</u>	<u>PR</u>	Flowline			
Frame and Lid To Be Adjusted				Dashed Property Line				Ditch Check			
Domestic Service Box To Be Adjusted				Solid Property/Lot Line				Headwall			
Valve Vault To Be Adjusted				Section/Grant Line				Inlet			
Special Adjustment				Quarter Section Line				Manhole			
Item To Be Abandoned				Quarter/Quarter Section Line				Summit			
Item To Be Moved				County/Township Line				Roadway Ditch Flow			
Item To Be Relocated				State Line				Swale			
Pavement Removal and Replacement				Iron Pipe Found				Catch Basin			
				Iron Pipe Set				Culvert End Section			
				Survey Marker				Water Surface Indicator			
				Property Line Symbol				Riprap			
				Same Ownership Symbol (Half Size)				<u>HYDRAULICS ITEMS</u>		<u>EX</u>	<u>PR</u>
				Northwest Quarter Corner (Half Size)				Overflow			
				Section Corner (Half Size)				Sheet Flow			
				Southeast Quarter Corner (Half Size)				Hydrant Outlet			

Illinois Department of Transportation

PASSED January 1, 2018
 ENGINEER OF POLICY AND PROCEDURES

APPROVED January 1, 2019
 ENGINEER OF DESIGN AND ENVIRONMENT

ISDHD 1-187

**STANDARD SYMBOLS
 ABBREVIATIONS
 AND PATTERNS**

(Sheet 2 of 9)

STANDARD 000001-07

**LIGHTING
(contd.)**

EX

PR

Pull Point		
Handhole		
Heavy Duty Handhole		
Junction Box		
Light Unit Comb.		
Electrical Ground		
Traffic Flow Arrow		
High Mast Pole (Half Size)		
Light Unit-1		

PAVEMENT (MISC.)

EX

PR

Keyed Long, Joint		
Keyed Long, Joint w/Tie Bars		
Sawed Long, Joint w/Tie Bars		
Bituminous Shoulder		
Bituminous Taper		
Stabilized Driveway		
Widening		

PAVEMENT MARKINGS

EX

PR

Handicap Symbol		
RR Crossing		
Raised Marker Amber 1 Way		
Raised Marker Amber 2 Way		
Raised Marker Crystal 1 Way		
Two Way Turn Left		
Shoulder Diag. Pattern		
Skip-Dash White		
Skip-Dash Yellow		
Stop Line		
Solid Line		
Double Centerline		
Dotted Lines		

Illinois Department of Transportation

PASSED *[Signature]* January 1, 2019
ENGINEER OF POLICY AND PROCEDURES

APPROVED *[Signature]* January 1, 2019
ENGINEER OF DESIGN AND ENVIRONMENT

ISSUED 1.1.97

**STANDARD SYMBOLS,
ABBREVIATIONS
AND PATTERNS**

[Sheet 4 of 9]

STANDARD 000001-07

PAVEMENT MARKINGS
(contd.)

CL 2Ln 2Way
RRPM 12.2 m (40') o.c.

CL 2Ln 2Way
RRPM 80' (24.4 m) o.c.

CL Multilane Div.
RRPM 40' (12.2 m) o.c.

CL Multilane Div.
RRPM 80' (24.4 m) o.c.

CL Multilane Div. Dbl.
RRPM 80' (24.4 m) o.c.

CL Multilane Undiv.

Two Way Turn Left Line

Urban Combination Left

Urban Combination Right

Urban Left Turn Arrow

Urban Right Turn Arrow

Urban Left Turn Only

Urban Right Turn Only

Urban Thru Only

EX

PR

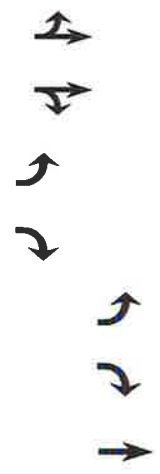
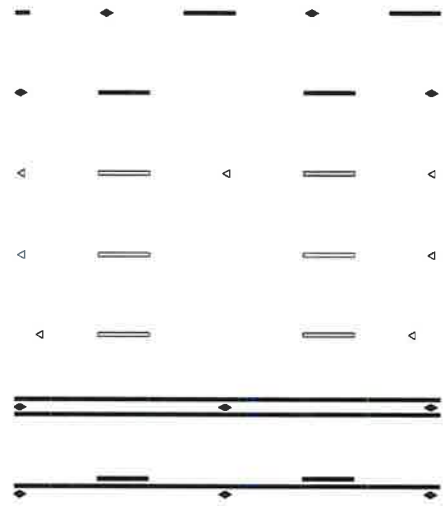

ONLY ONLY ONLY

RAILROAD ITEMS

EX

PR

Abandoned Railroad

Railroad

Railroad Point

Control Box

Crossing Gate

Flashing Signal

Railroad Cant. Mast Arm

Crossbuck

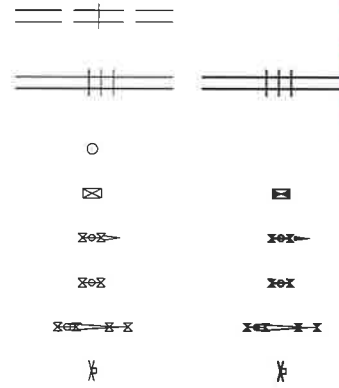

REMOVAL ITEMS

EX

PR

Removal Tic

Bituminous Removal

Hatch Pattern

Tree Removal Single

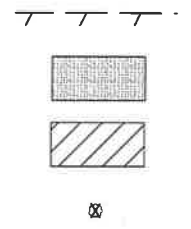

RIGHT OF WAY ITEMS

EX

PR

Future ROW Corner Monument

ROW Marker

ROW Line

Easement

Temporary Easement

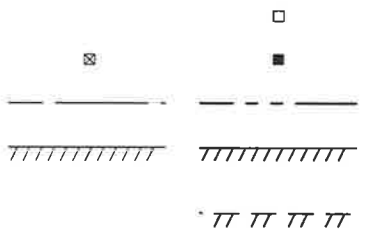

Illinois Department of Transportation

PASSED: January 1, 2019

ENGINEER OF POLICY AND PROCEDURES

APPROVED: January 1, 2019

ENGINEER OF DESIGN AND ENVIRONMENT

ISSUED 1-1-19

STANDARD SYMBOLS

ABBREVIATIONS

AND PATTERNS

(Sheet 5 of 9)

STANDARD 000001-07

PAVEMENT MARKINGS
(contd.)

EX

PR

Urban U-Turn



Urban Combined U-Turn



Rural Combination Left



Rural Combination Right



Rural Left Turn Arrow



Rural Right Turn Arrow



Rural Left Turn Only



ONLY



Rural Right Turn Only



ONLY



Rural Thru Only



ONLY



Bike Lane Symbol

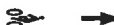

Bike Lane Text



Bike Path Shared



Bike Shared Roadway



Illinois Department of Transportation

PASSED *M. J. B. J.* January 1, 2019
ENGINEER OF POLICY AND PROCEDURES

APPROVED *J. E. C.* January 1, 2019
ENGINEER OF DESIGN AND ENVIRONMENT

ISSUED 1-1-97

STANDARD SYMBOLS
ABBREVIATIONS
AND PATTERNS

(Sheet 6 of 9)

STANDARD 000001-07

RIGHT OF WAY ITEMS
(contd.)

	EX	PR
Access Control Line	— — — — —	— AC — — — — —
Access Control Line & ROW	— — — — — AC — — — — —	— — — — — AC — — — — —
Access Control Line & ROW with Fence	— — — — — AC — — — — —	— — — — — AC — — — — —
Excess ROW Line		— XS — — — — —

ROADWAY PLAN ITEMS

	EX	PR
Cable Barrier	— ○ — ○ — ○ — ○ —	— ● — ● — ● — ● —
Concrete Barrier	— — — — —	— — — — —
Edge of Pavement	— — — — —	— — — — —
Bit Shoulders, Medians and C&G Line	— — — — —	— — — — —
Aggregate Shoulder	— — — — —	— — — — —
Sidewalks, Driveways	— — — — —	— — — — —
Guardrail	— □ — □ — □ — □ —	— □ — □ — □ — □ —
Guardrail Post	○	○
Traffic Sign	⊥	⊥
Corrugated Median	▨ ▨ ▨ ▨ ▨	▨ ▨ ▨ ▨ ▨
Impact Attenuator		○ ○ ○ ○ ○
North Arrow with District Office (Half Size)	↑	
Match Line		STA. 45+00
Slope Limit Line	— — — — —	
Typical Cross-Section Line	— — — — —	— — — — —

ROADWAY PROFILES

	EX	PR
P.I. Indicator	▲	▲
Point Indicator	○	○
Earthworks Balance Point		◐
Begin Point		◑
Vert. Curve Data	VPI = ELEV = L = E =	VPI = ELEV = L = E =
Ditch Profile Left Side	— — — — —	— — — — —
Ditch Profile Right Side	— — — — —	— — — — —
Roadway Profile Line	— — — — —	— — — — —
Storm Sewer Profile Left Side	— — — — —	— — — — —
Storm Sewer Profile Right Side	— — — — —	— — — — —

SIGNING ITEMS

	EX	PR
Cone, Drum or Barricade	○	○
Barricade Type I	▨ ▨ ▨ ▨ ▨	— — — — —
Barricade Type II		— — — — —
Barricade With Edge Line		— — — — —
Flashing Light Sign	○	○
Panels I	▨ ▨ ▨ ▨ ▨	▨ ▨ ▨ ▨ ▨
Panels II		▨ ▨ ▨ ▨ ▨
Direction of Traffic	→	→
Sign Flag (Half Size)	◇	◇

SIGNING ITEMS
(contd.)

	EX	PR
Reverse Left W1-4L (Half Size)		⤴
Reverse Right W1-4R (Half Size)		⤵
Two Way Traffic Sign W6-3 (Half Size)		↕
Detour Ahead W20-2(O) (Half Size)		⤴
Left Lane Closed Ahead W20-5L(O) (Half Size)		⤴
Right Lane Closed Ahead W20-5R(O) (Half Size)		⤵
Road Closed Ahead W20-3(O) (Half Size)		⤴
Road Construction Ahead W20-1(O) (Half Size)		⤴
Single Lane Ahead (Half Size)		⤴
Transition Left W4-2L (Half Size)		⤴
Transition Right W4-2R (Half Size)		⤵

Illinois Department of Transportation

PASSED: [Signature] JANUARY 3, 2019
ENGINEER OF POLICY AND PROCEDURES

APPROVED: [Signature] JANUARY 3, 2019
ENGINEER OF DESIGN AND ENVIRONMENT

ISSUED 1-1-97

STANDARD SYMBOLS, ABBREVIATIONS AND PATTERNS
(Sheet 7 of 9)

STANDARD 000001-07

<u>SIGNING ITEMS</u> (contd.)	<u>EX</u>	<u>PR</u>
One Way Arrow Lrg. W1-6-(O) (Half Size)		
Two Way Arrow Large W1-7-(O) (Half Size)		
Detour M4-10L-(O) (Half Size)		
Detour M4-10R-(O) (Half Size)		
One Way Left R6-1L (Half Size)		
One Way Right R6-1R (Half Size)		
Left Turn Lane R3-1100L (Half Size)		
Keep Left R4-7AL (Half Size)		
Keep Left R4-7BL (Half Size)		
Keep Right R4-7AR (Half Size)		
Keep Right R4-7BR (Half Size)		
Stop Here On Red R10-6-AL (Half Size)		
Stop Here On Red R10-6-AR (Half Size)		
No Left Turn R3-2 (Half Size)		
No Right Turn R3-1 (Half Size)		
Road Closed R11-2 (Half Size)		
Road Closed Thru Traffic R11-2 (Half Size)		

<u>STRUCTURES ITEMS</u>	<u>EX</u>	<u>PR</u>
Box Culvert Barrel		
Box Culvert Headwall		
Bridge Pier		
Bridge		
Retaining Wall		
Temporary Sheet Piling		

<u>TRAFFIC SHEET ITEMS</u>	<u>EX</u>	<u>PR</u>
Cable Number		
Left Turn Green		
Left Turn Yellow		
Signal Backplate		
Signal Section 8" (200 mm)		
Signal Section 12" (300 mm)		
Walk/Don't Walk Letters		
Walk/Don't Walk Symbols		

<u>TRAFFIC SIGNAL ITEMS</u>	<u>EX</u>	<u>PR</u>
Galv. Steel Conduit		
Underground Cable		
Detector Loop Line		
Detector Loop Large		
Detector Loop Small		
Detector Loop Quadrapole		

**STANDARD SYMBOLS
ABBREVIATIONS
AND PATTERNS**
(Sheet 8 of 9)

STANDARD 000001-07

Illinois Department of Transportation

PASSED *[Signature]* January 1, 2019
ENGINEER OF POLICY AND PROCEDURES

APPROVED *[Signature]* January 1, 2019
ENGINEER OF DESIGN AND ENVIRONMENT

ISSUED 1-1-97

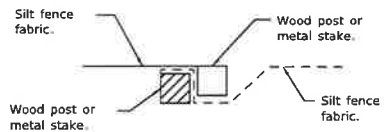

Place end-post (stake) of first silt fence adjacent to end-post (stake) of second silt fence with fabric positioned as shown.

STEP 1

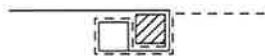

Rotate posts (stakes) together 180° clockwise and drive both posts (stakes) 18 (450) into ground.

STEP 2

ATTACHING TWO SILT FILTER FENCES

(Not applicable for J-hooks)

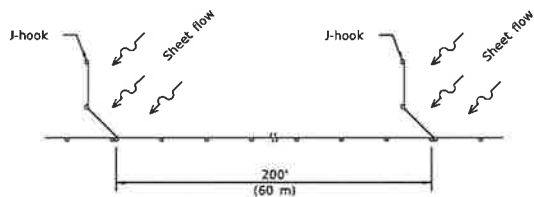

SILT FILTER J-HOOK PLACEMENT

Wood post or metal stake (typical)

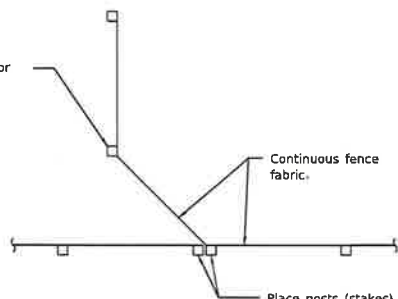

J-HOOK

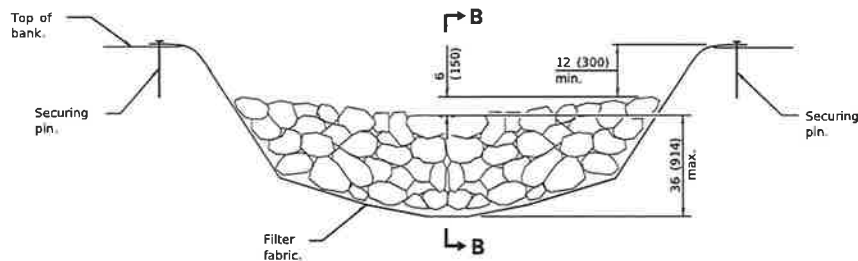

ELEVATION

When the ditch check is within the clear zone and the road is open to traffic, the traffic approach slope of the aggregate shall be 1:4 (V:H).

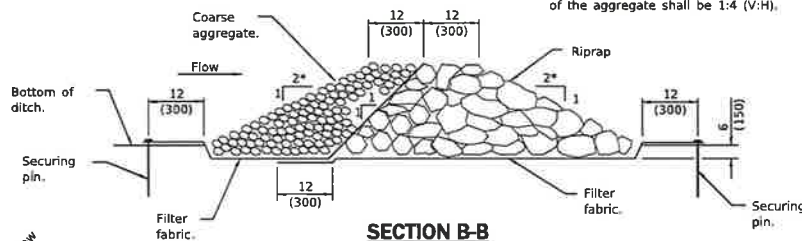

SECTION B-B

AGGREGATE DITCH CHECK

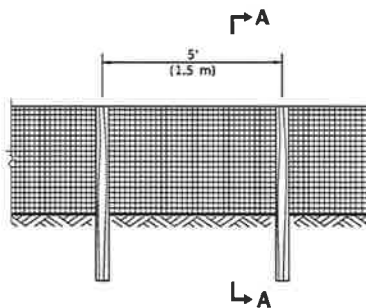

ELEVATION

SILT FILTER FENCE AS A PERIMETER EROSION BARRIER

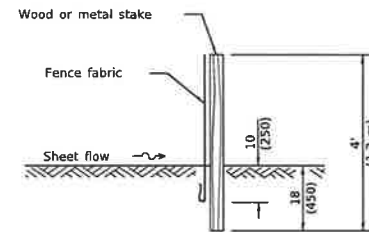

SLICE METHOD

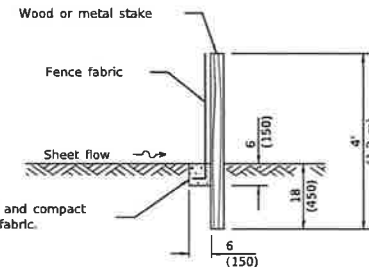

TRENCH METHOD

SECTION A-A

Excavate, backfill and compact trench to secure fabric.

GENERAL NOTES

The installation details and dimensions shown for perimeter erosion barriers shall also apply for inlet and pipe protection.

All dimensions are in inches (millimeters) unless otherwise shown.

Illinois Department of Transportation

PASSED JANUARY 7, 2013
Michael Brand
 ENGINEER OF POLICY AND PROCEDURES

APPROVED JANUARY 7, 2013
[Signature]
 ENGINEERS OF DESIGN AND ENVIRONMENT

ISSUED 1-1-97

DATE	REVISIONS
1-1-13	Corrected notation for flowline (E) on SEDIMENT BASIN ELEVATION.
1-1-12	Omitted hay/straw perimeter barrier. Added SLICE METHOD to SECTION A-A.

TEMPORARY EROSION CONTROL SYSTEMS

(Sheet 1 of 1)

STANDARD 280001-07

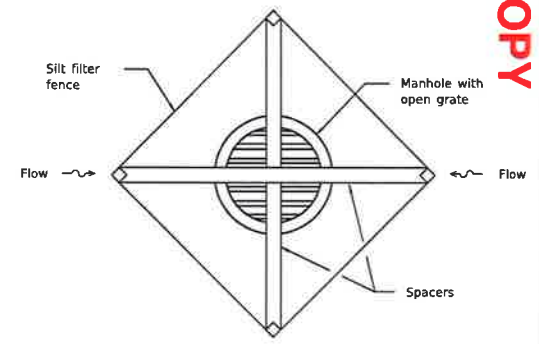
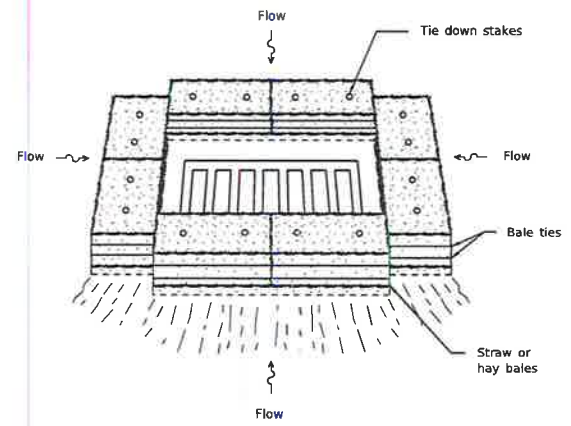
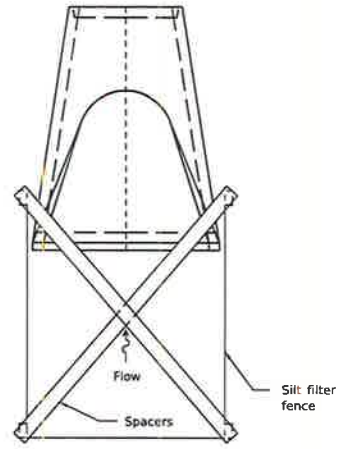
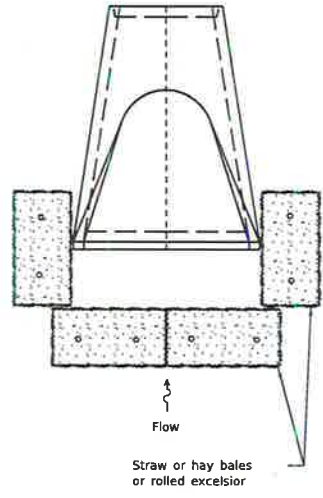

INLET AND PIPE PROTECTION

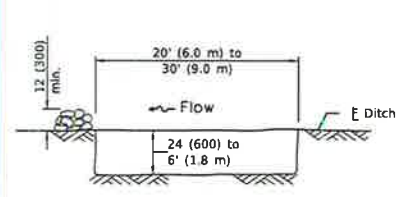

The performance of the basin will improve if put into a series.

ELEVATION

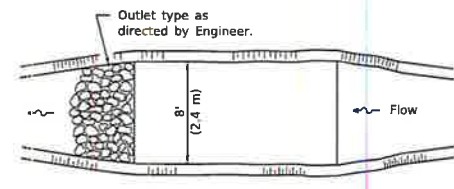

The long dimension should be parallel with the direction of the flow. Accumulated silt shall be removed anytime the basins become 75% filled.

PLAN

SEDIMENT BASIN

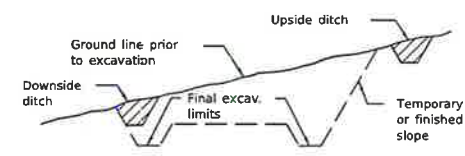

TYPICAL CUT CROSS-SECTION

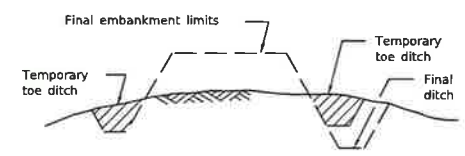

TYPICAL FILL CROSS-SECTION

TEMPORARY DITCHES FOR CUT & FILL SECTIONS

Illinois Department of Transportation

PASSED January 1, 2013

Michael Beard
ENGINEER OF POLICY AND PROCEDURES

APPROVED January 1, 2013

ENGINEER OF DESIGN AND ENVIRONMENT

ISSUED 1-1-07

TEMPORARY EROSION CONTROL SYSTEMS

(Sheet 2 of 4)

STANDARD 280001-07

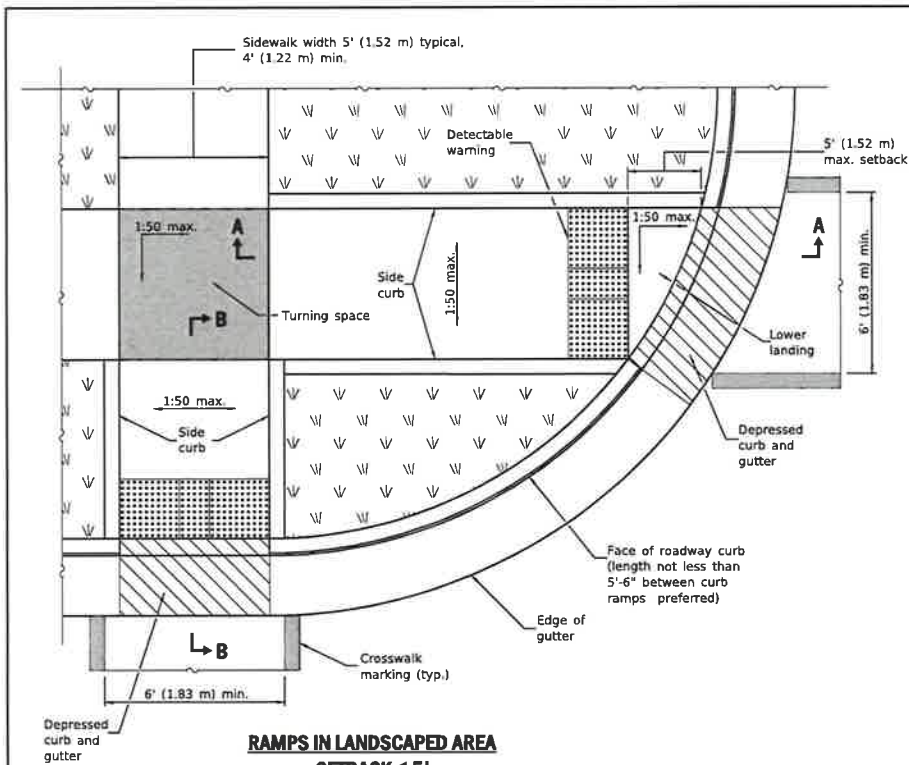

**RAMPS IN LANDSCAPED AREA
SETBACK ≤ 5'**

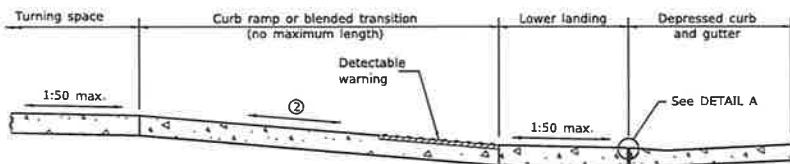

SECTION A-A

② The running slope of a curb ramp shall be 1:20 min. and 1:12 max. The running slope of a blended transition shall be 1:20 max.

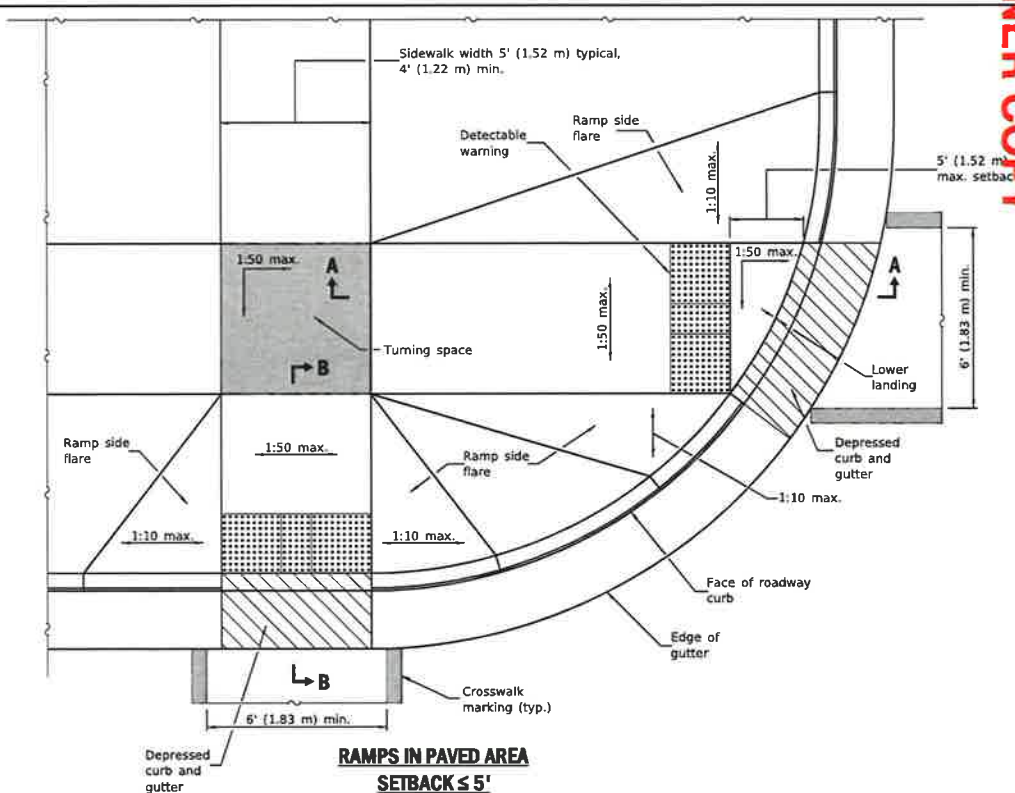

**RAMPS IN PAVED AREA
SETBACK ≤ 5'**

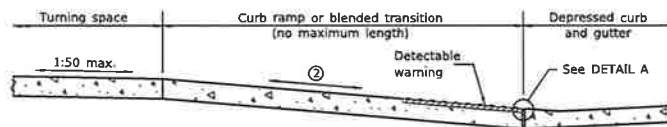

SECTION B-B

② The running slope of a curb ramp shall be 1:20 min. and 1:12 max. The running slope of a blended transition shall be 1:20 max.

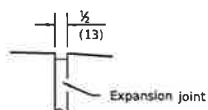

DETAIL A

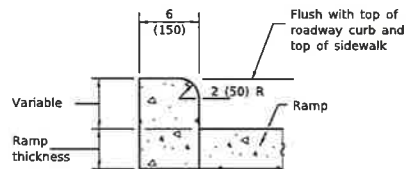

SIDE CURB DETAIL

See Sheet 2 for GENERAL NOTES.

Illinois Department of Transportation

PASSED January 1, 2016
 ENGINEER OF POLICY AND PROCEDURES
 APPROVED January 1, 2018
 ENGINEER OF DESIGN AND ENVIRONMENT

ISSUED 1-1-17

DATE	REVISIONS
1-1-19	Removed "15-foot rule", added "Blended transitions" and placement tolerances for detectable warnings.
1-1-18	Omitted diagonal slope at turning spaces and lower landings.

**PERPENDICULAR CURB RAMPS
FOR SIDEWALKS**

(Sheet 1 of 2)

STANDARD 424001-11

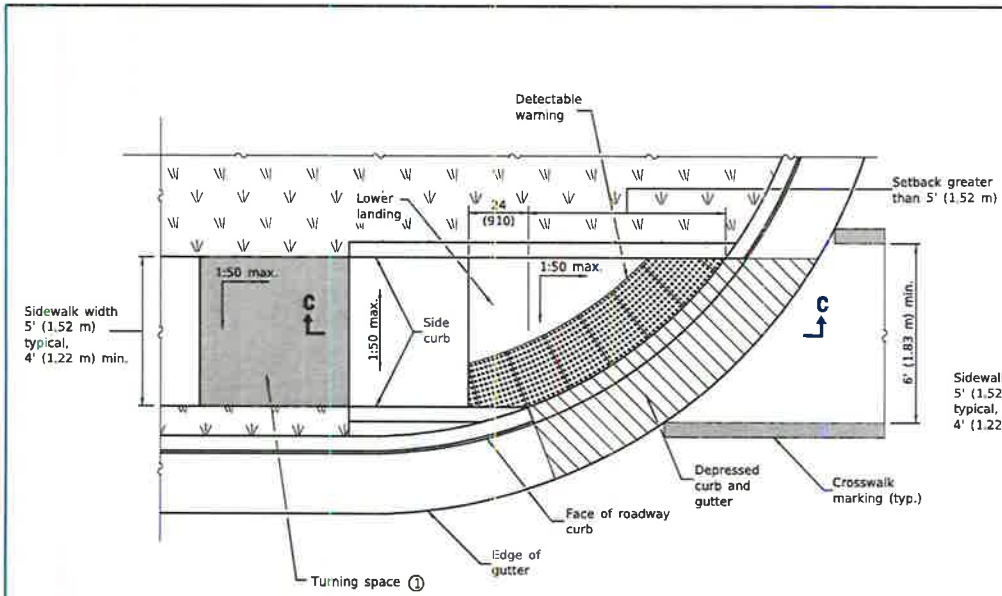

**RAMP IN LANDSCAPED AREA
SETBACK > 5'**

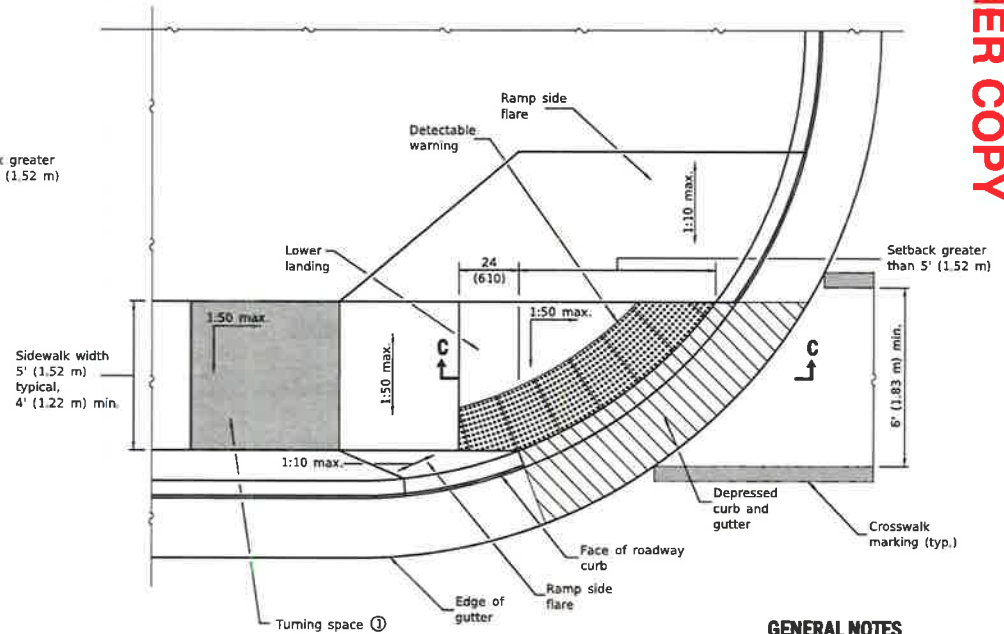

**RAMP IN PAVED AREA
SETBACK > 5'**

GENERAL NOTES

All slope ratios are expressed as units of vertical displacement to units of horizontal displacement (V:H).

Where the turning space is constrained on a side opposite a ramp, the minimum length of the turning space in the direction of the ramp-run shall be 5' (1.52 m).

Where 1:50 maximum slope is shown, 1:64 is preferred.

Detectable warnings are shown in their ideal locations but the following placement tolerances are allowed.

Side Border - Detectable warnings should extend the full width of the walking surface (excluding flared sides) but a border along each side up to 2 in. (50 mm) in width is allowed.

Curb Set-Back - Detectable warnings located at the back of curb should closely align with the curb but a gap up to 6 in. (150 mm) behind the curb is allowed.

See Standard 606001 for details of depressed curb adjacent to curb ramp.

All dimensions are in inches (millimeters) unless otherwise shown.

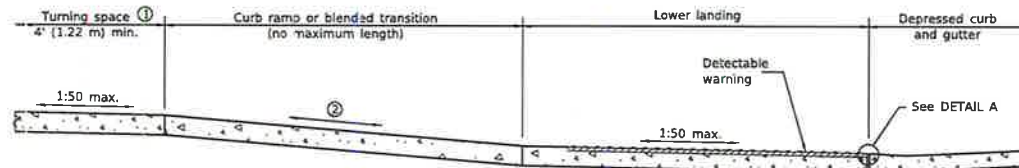

SECTION C-C

- ① This turning space not required for blended transitions.
- ② The running slope of a curb ramp shall be 1:20 min. and 1:12 max. The running slope of a blended transition shall be 1:20 max.

Illinois Department of Transportation	
PASSED	January 3, 2018
ENGINEER OF POLICY AND PROCEDURES	
APPROVED	January 3, 2018
ENGINEER OF DESIGN AND ENVIRONMENT	

PERPENDICULAR CURB RAMP FOR SIDEWALKS
(Sheet 2 of 2)
STANDARD 424001-11

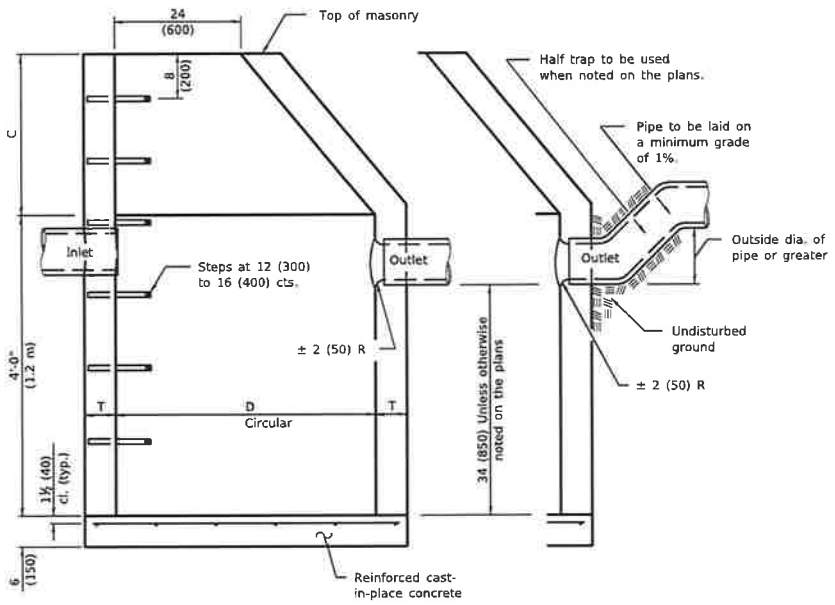

ELEVATION
(Standard Outlet)

ELEVATION
(Half Trap)

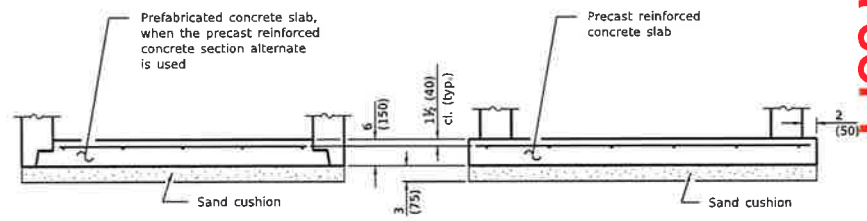

ALTERNATE BOTTOM SLAB

ALTERNATE MATERIALS FOR WALLS	D	C ^e	T (min.)
Concrete Masonry Unit	4'-0" (1.2 m)	30 (750)	5 (125)
	5'-0" (1.5 m)	3'-9" (1.15 m)	5 (125)
Brick Masonry	4'-0" (1.2 m)	30 (750)	8 (200)
	5'-0" (1.5 m)	3'-9" (1.15 m)	8 (200)
Precast Reinforced Concrete Section	4'-0" (1.2 m)	30 (750)	4 (100)
	5'-0" (1.5 m)	3'-9" (1.15 m)	5 (125)
Cast-in-place Concrete	4'-0" (1.2 m)	30 (750)	6 (150)
	5'-0" (1.5 m)	3'-9" (1.15 m)	6 (150)

* For precast reinforced concrete sections, dimension "C" may vary from the dimension given to plus 6 (150).

GENERAL NOTES

Bottom slabs shall be reinforced with a minimum of 0.20 sq. in./ft (420 sq. mm/m) in both directions with a maximum spacing of 12 (300).

Bottom slabs may be connected to the riser as determined by the fabricator; however, only a single row of reinforcement around the perimeter may be utilized.

See Standard 602601 for optional precast reinforced concrete flat slab top.

See Standard 602701 for details of steps.

All dimensions are in inches (millimeters) unless otherwise shown.

DATE	REVISIONS
1-1-11	Added 'Outside' to half trap note. Detail rein. in slabs.
	Revised general notes.
1-1-09	Switched units to English (metric).

**CATCH BASIN
TYPE A**

STANDARD 602001-02

Illinois Department of Transportation

PASSED January 1, 2011
Michael Beard
 ENGINEER OF POLICY AND PROCEDURES

APPROVED January 1, 2011
Scott Smith
 ENGINEER OF DESIGN AND ENVIRONMENT

ISSUED 1-1-11

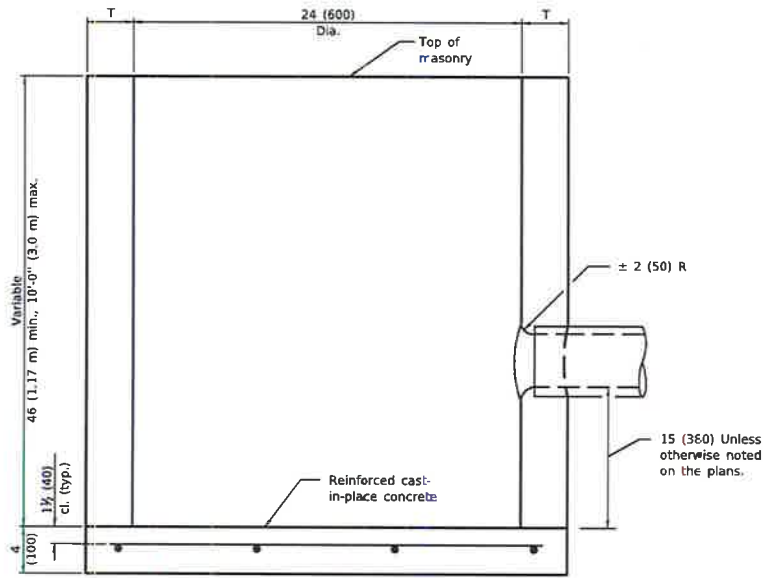

ALTERNATE MATERIALS FOR WALLS	T (min)
Precast Reinforced Concrete Section	3 (75)
Concrete Masonry Unit	5 (125)
Cast-in-Place Concrete	6 (150)
Brick Masonry	8 (200)

ELEVATION

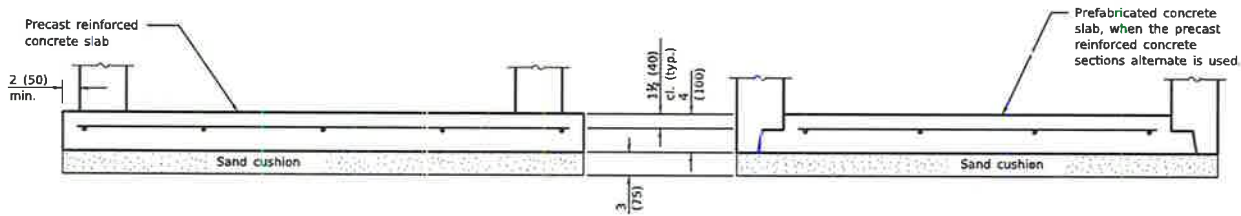

ALTERNATE BOTTOM SLAB

GENERAL NOTES

Bottom slabs shall be reinforced with a minimum of 0.27 sq. in./ft. (570 sq. mm/m) in both directions with a maximum spacing of 9 (230).

Bottom slabs may be connected to the riser as determined by the fabricator; however, only a single row of reinforcement around the perimeter may be utilized.

All dimensions are in inches (millimeters) unless otherwise shown.

DATE	REVISIONS
1-1-11	Detailed rein. in slabs.
	Added max. limit to height.
	Added general notes.
1-1-09	Switched units to English (metric).

CATCH BASIN TYPE C

STANDARD 602011-02

Illinois Department of Transportation

PASSED January 1, 2011
Michael Beard
 ENGINEER OF POLICY AND PROCEDURES

APPROVED January 1, 2011
[Signature]
 ENGINEER OF DESIGN AND ENVIRONMENT

DESIGNED 11-1-09

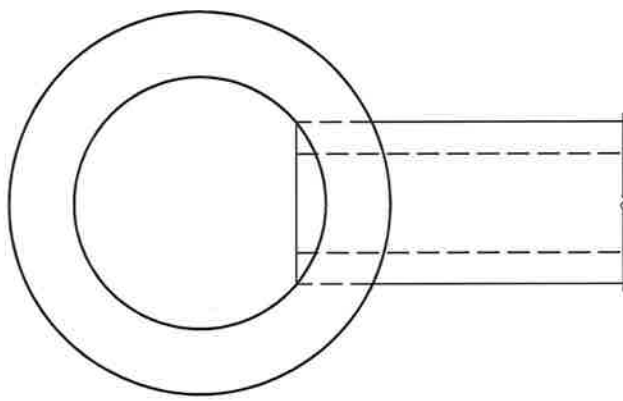

PLAN

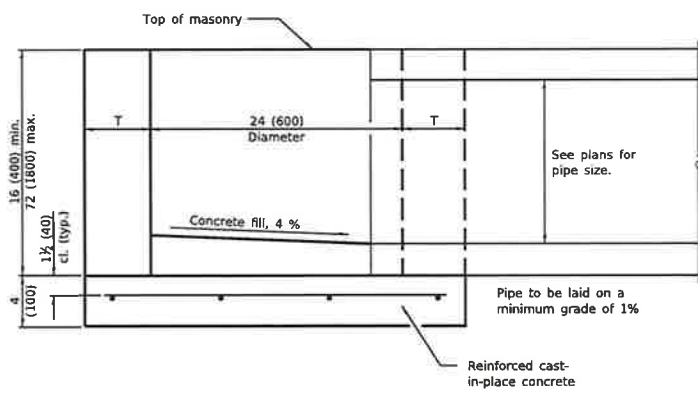

ELEVATION

ALTERNATE MATERIALS FOR WALLS	T
BRICK MASONRY	8 (200)
CAST-IN-PLACE CONCRETE	6 (150)
CONCRETE MASONRY UNIT	5 (125)
PRECAST REINFORCED CONCRETE SECTION	3 (75)

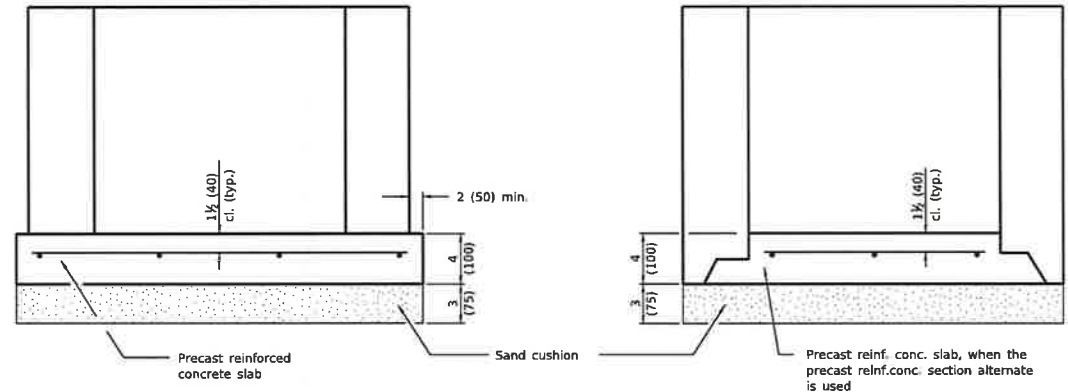

ALTERNATE METHODS

GENERAL NOTES

Bottom slabs shall be reinforced with a minimum of 0.24 sq. in./ft. (510 sq. mm/m) in both directions with a maximum spacing of 10 (250).

Bottom slabs may be connected to the riser as determined by the fabricator; however, only a single row of reinforcement around the perimeter may be utilized.

All dimensions are in inches (millimeters) unless otherwise shown.

DATE	REVISIONS
1-1-14	Increased height to 72 (1800) maximum.
1-1-11	Detailed rein. in slabs. Added max. limit to height. Added general notes.

INLET - TYPE A

STANDARD 602301-04

Illinois Department of Transportation

PASSED January 1, 2014
Michael Beard
 ENGINEER OF POLICY AND PROCEDURES

APPROVED January 1, 2014
[Signature]
 ENGINEER OF DESIGN AND ENVIRONMENT

ISSUED 1-1-97

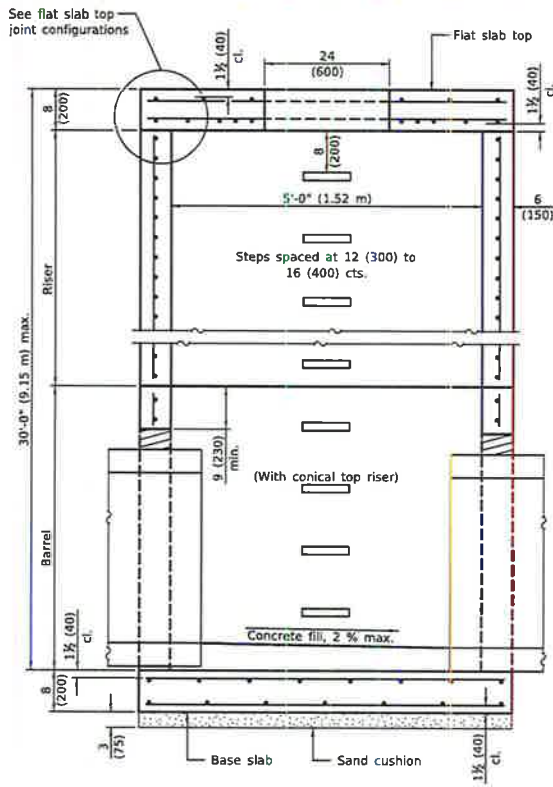

SECTION PARALLEL TO PIPE
(Without conical top riser)

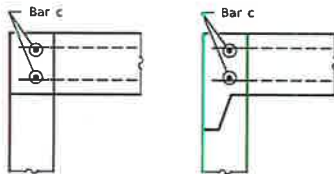

FLAT SLAB TOP JOINT CONFIGURATIONS
(Shown at access hole)

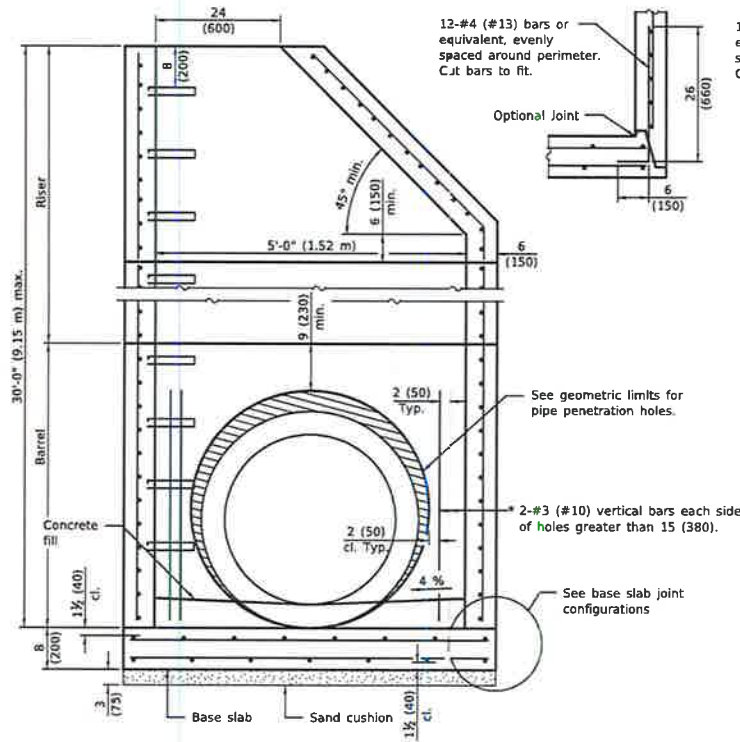

SECTION PERPENDICULAR TO PIPE
(With conical top riser)

* As an alternate, the barrel wall reinforcement may be reduced to riser wall reinforcement with #3 (#10) bars placed around the pipe penetration holes as shown. This option may be utilized when the pipe penetration holes are formed as opposed to cored.

GEOMETRIC LIMITS FOR PIPE PENETRATION HOLES

1. A minimum of 9 (230) of monolithic reinforced concrete shall be maintained above pipe penetration holes > 32 (810).
2. A minimum 12 (300) inside arc length of reinforced concrete shall be maintained between pipe penetration holes > 15 (380).
3. A maximum of 60 percent of the inside perimeter of the reinforced concrete manhole walls may be removed.
4. Horizontal joints that intersect pipe penetration holes > 15 (380) shall have one joint splice for every location around the perimeter of the joint where the inside arc length between pipe penetration holes is < 24 (600). See joint splice detail.
5. The recommended pipe penetration hole is equal to the O.D. of the pipe plus 4 (100).
6. Only pipe penetration holes ≤ 15 (380) are allowed in riser sections.

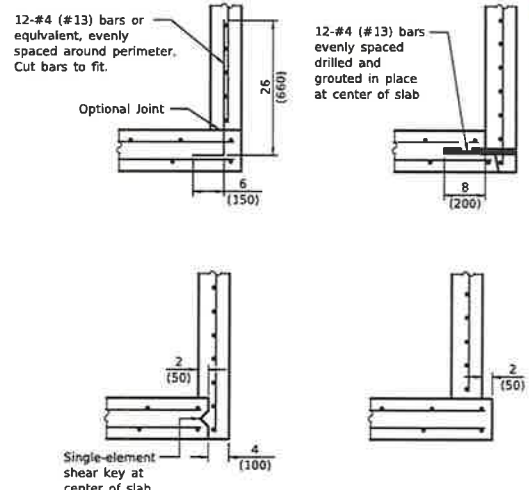

BASE SLAB JOINT CONFIGURATIONS

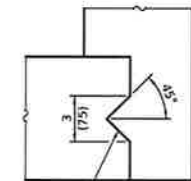

SHEAR KEY GEOMETRY
(Reinforcement not shown for clarity)

GENERAL NOTES

The manufacturer shall ensure that all precast manhole sections are additionally reinforced where required to resist damage from handling, shipping and installation stresses.
Lifting holes shall be located in the sections as per the manufacturer's recommendations, except as noted.
See Standard 602701 for details of manhole steps.
All dimensions are in inches (millimeters) unless otherwise noted.

DATE	REVISIONS
3-1-19	Moved wall reinforcement from inside face to middle.
1-1-19	Expanded / refined reinforcement options. Increased manhole depths.

PRECAST MANHOLE TYPE A
5' (1.52 m) DIAMETER

STANDARD 602402-02

Illinois Department of Transportation

PASSED March 2, 2019
ENGINEER OF POLICY AND PROCEDURES

APPROVED March 3, 2019
ENGINEER OF DESIGN AND ENVIRONMENT

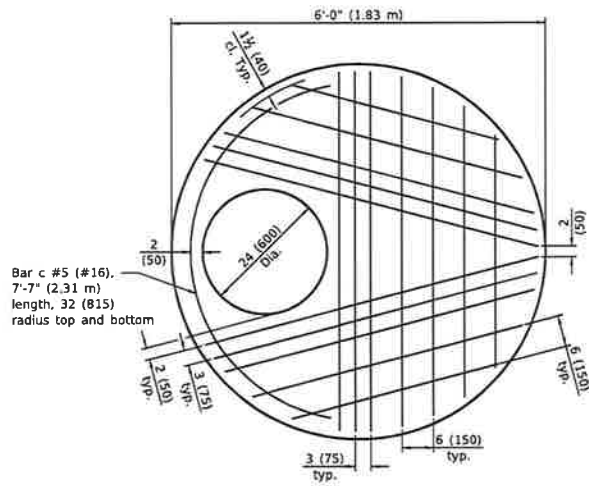

PLAN - FLAT SLAB TOP

(Showing layout of bottom reinforcement bars and c bars)

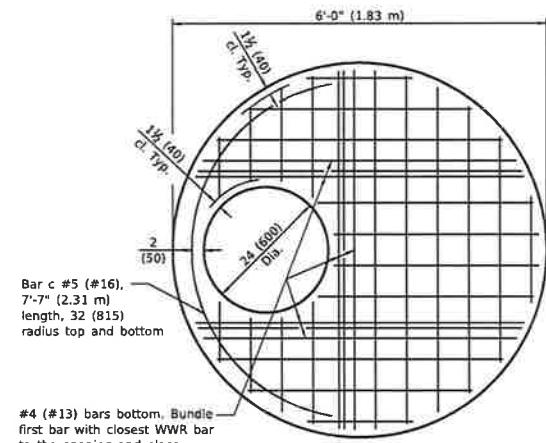

PLAN - FLAT SLAB TOP

(Showing layout of welded wire reinforcement and c bars)

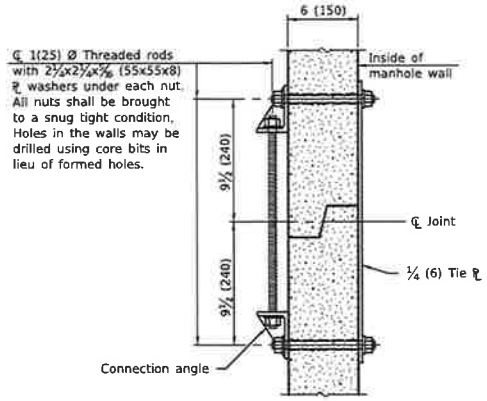

JOINT SPLICE

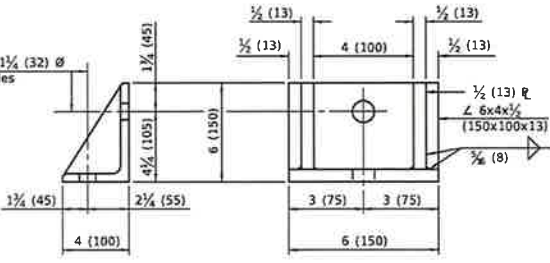

CONNECTION ANGLE

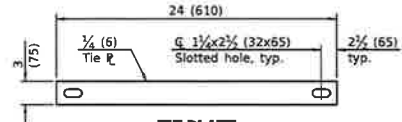

TIE PLATE

Use 1 (25) Ø Threaded rods with 2 1/2"x2 1/2"x3/4" (55x55x8) washers under each nut. All nuts shall be brought to a snug tight condition. Holes in the walls may be drilled using core bits in lieu of formed holes.

FLAT SLAB TOP REINFORCEMENT

Location	WWR (each direction)		Rebar (each direction except as noted)		
	A _s (min.)	Spacing (max.)	A _s (min.)	Spacing (max.)	Bar Size
Top Mat	0.11 sq. in./ft. (233 sq. mm/m)	18 (450)	0.11 sq. in./ft. (233 sq. mm/m)	18 (450)	#3 or #4 (#10) (#13)
Bottom Mat	** 0.40 sq. in./ft. (847 sq. mm/m)	6 (150)	See plan view for rebar orientation and spacing and this table for bar size		#4 (#13)

** Only one layer of WWR permitted to avoid congestion.

WALL REINFORCEMENT

Location	Orientation	WWR or Rebar	
		A _s (min.)	Spacing (max.)
Riser	Circumferential	0.15 sq. in./ft. (318 sq. mm/m)	6 (150)
	Vertical	0.045 sq. in./ft. (95 sq. mm/m)	8 (200)
Barrel	Circumferential	0.15 sq. in./ft. (318 sq. mm/m)	6 (150)
	Vertical	0.16 sq. in./ft. (339 sq. mm/m)	4 (100)

BASE SLAB REINFORCEMENT

Location	Total Height	WWR or Rebar (each direction)	
		A _s (min.)	Spacing (max.)
Top Mat	≤ 20 ft. (6.10 m)	0.24 sq. in./ft. (508 sq. mm/m)	10 (250)
	> 20 ft. (6.10 m)	0.28 sq. in./ft. (593 sq. mm/m)	8 (200)
Bottom Mat	All	0.11 sq. in./ft. (233 sq. mm/m)	18 (450)

Illinois Department of Transportation

PASSED March 1, 2019

ENGINEER OF POLICY AND PROCEDURES

APPROVED March 1, 2019

ENGINEER OF DESIGN AND ENVIRONMENT

15251 1-1-18

PRECAST MANHOLE TYPE A

5' (1.52 m) DIAMETER

(Sheet 2 of 2)

STANDARD 602402-02

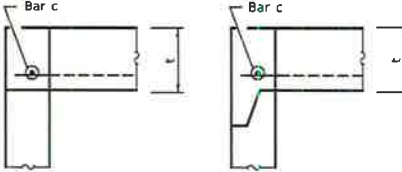

FLAT SLAB TOP JOINT CONFIGURATIONS
FOR D = 36 (900) AND D = 4'-0" (1.22 m)
 (Shown at access hole)

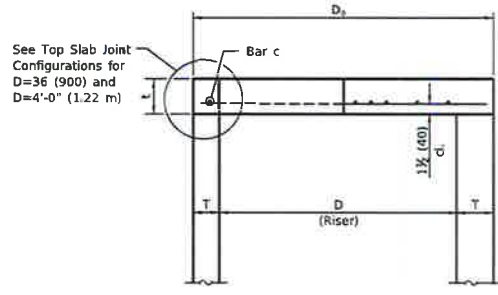

SECTION THRU FLAT SLAB TOP
FOR D = 36 (900) AND D = 4'-0" (1.22 m)

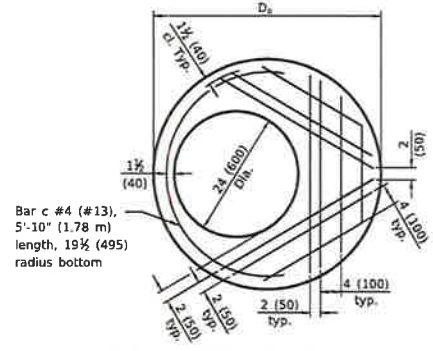

PLAN - FLAT SLAB TOP FOR D = 36 (900)
 (Showing layout of reinforcement bars and c bars)

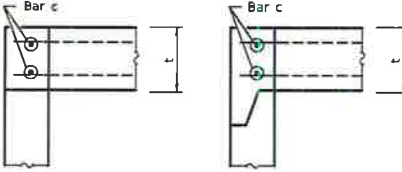

FLAT SLAB TOP JOINT CONFIGURATIONS
D = 5'-0" (1.52 m)
 (Shown at access hole)

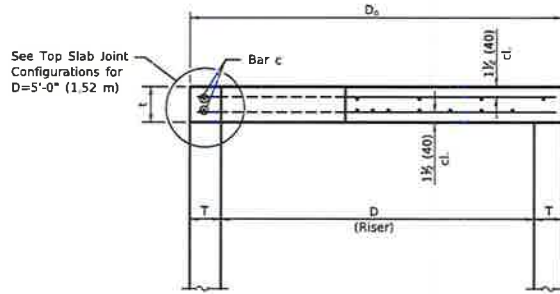

SECTION THRU FLAT SLAB TOP
FOR D = 5'-0" (1.52 m)

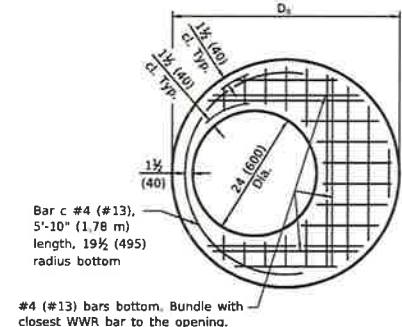

PLAN - FLAT SLAB TOP FOR D = 36 (900)
 (Showing layout of welded wire reinforcement and c bars)

TABLE

D	T	D _o (min.)	t
36 (900)	See applicable Standards	D + 2T	6 (150)
4'-0" (1.2 m)			6 (150)
5'-0" (1.5 m)			8 (200)

GENERAL NOTES

The flat slab top may be used in lieu of the tapered tops shown on Standards 602001, 602016, or 602306 at the option of the Contractor or when field conditions prohibit the use of tapered tops.

Lifting holes shall be located in the sections as per the manufacturer's recommendations.

All dimensions are in inches (millimeters) unless otherwise shown.

Illinois Department of Transportation

PASSED: [Signature] January 3, 2019
 ENGINEER OF POLICY AND PROCEDURES

APPROVED: [Signature] January 3, 2019
 ENGINEER OF DESIGN AND ENVIRONMENT

ISSUED: 1-1-19

DATE	REVISIONS
1-1-19	Expanded / refined reinforcement options.
1-1-18	Revised for compliance with LRFD.

**PRECAST REINFORCED
 CONCRETE FLAT SLAB TOP**

(Sheet 1 of 1)

STANDARD 602601-06

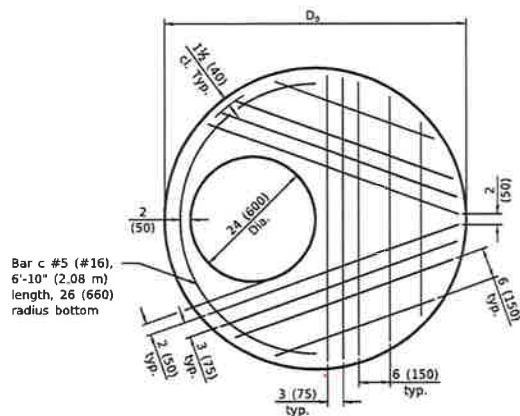

Bar c #5 (#16),
6'-10" (2.08 m)
length, 26 (660)
radius bottom

PLAN - FLAT SLAB TOP FOR D = 4'-0" (1.22 m)
(Showing layout of reinforcement bars and c bars)

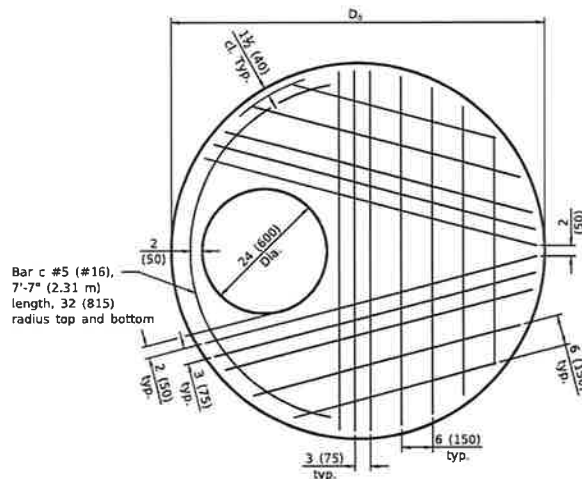

Bar c #5 (#16),
7'-7" (2.31 m)
length, 32 (815)
radius top and bottom

PLAN - FLAT SLAB TOP FOR D = 5'-0" (1.52 m)
(Showing layout of bottom reinforcement bars and c bars)

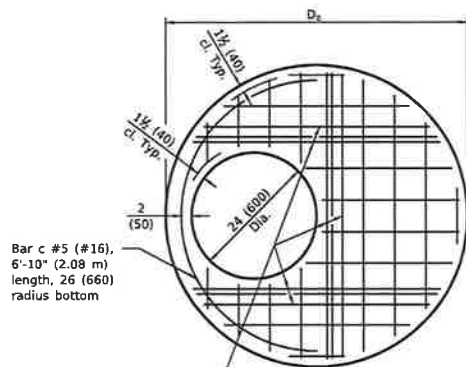

Bar c #5 (#16),
6'-10" (2.08 m)
length, 26 (660)
radius bottom

#5 (#16) bars bottom. Bundle
first bar with closest WWR bar
to the opening and place
second bar ±3 (75) away.

PLAN - FLAT SLAB TOP FOR D = 4'-0" (1.22 m)
(Showing layout of welded wire reinforcement and c bars)

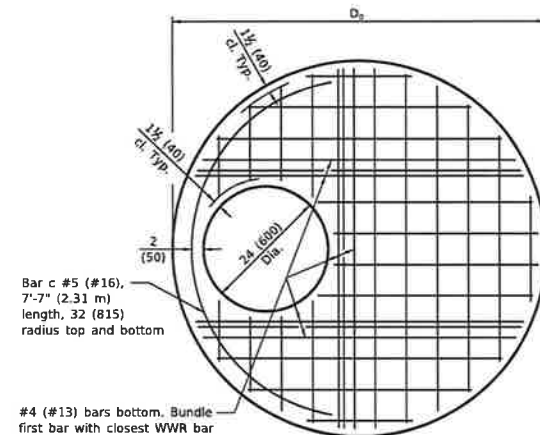

Bar c #5 (#16),
7'-7" (2.31 m)
length, 32 (815)
radius top and bottom

#4 (#13) bars bottom. Bundle
first bar with closest WWR bar
to the opening and place
second bar ±3 (75) away.

PLAN - FLAT SLAB TOP FOR D = 5'-0" (1.52 m)
(Showing layout of welded wire reinforcement and c bars)

FLAT SLAB TOP REINFORCEMENT FOR D = 36 (900)

Location	WWR (each direction)		Rebar		
	A _s (min.)	Spacing (max.)	A _s (min.)	Spacing (max.)	Bar Size
Bottom Mat	* 0.60 sq. in./ft. (1270 sq. mm/m)	6 (150)	See plan view for rebar orientation and spacing and this table for bar size		#4 (#13)

FLAT SLAB TOP REINFORCEMENT FOR D = 4'-0" (1.22 m)

Location	WWR (each direction)		Rebar		
	A _s (min.)	Spacing (max.)	A _s (min.)	Spacing (max.)	Bar Size
Bottom Mat	* 0.62 sq. in./ft. (1312 sq. mm/m)	6 (150)	See plan view for rebar orientation and spacing and this table for bar size		#5 (#16)

FLAT SLAB TOP REINFORCEMENT FOR D = 5'-0" (1.52 m)

Location	WWR (each direction)		Rebar (each direction except as noted)		
	A _s (min.)	Spacing (max.)	A _s (min.)	Spacing (max.)	Bar Size
Top Mat	0.11 sq. in./ft. (233 sq. mm/m)	18 (450)	0.11 sq. in./ft. (233 sq. mm/m)	18 (450)	#3 or #4 (#10) (#13)
Bottom Mat	* 0.40 sq. in./ft. (847 sq. mm/m)	6 (150)	See plan view for rebar orientation and spacing and this table for bar size		#4 (#13)

* Only one layer of WWR permitted to avoid congestion.

Illinois Department of Transportation

PASSED January 3, 2018

ENGINEER OF POLICY AND PROCEDURES

APPROVED January 3, 2018

ENGINEER OF DESIGN AND ENVIRONMENT

15255

1-13*

**PRECAST REINFORCED
CONCRETE FLAT SLAB TOP**

(Sheet 2 of 2)

STANDARD 602601-06

CAST IRON STEPS

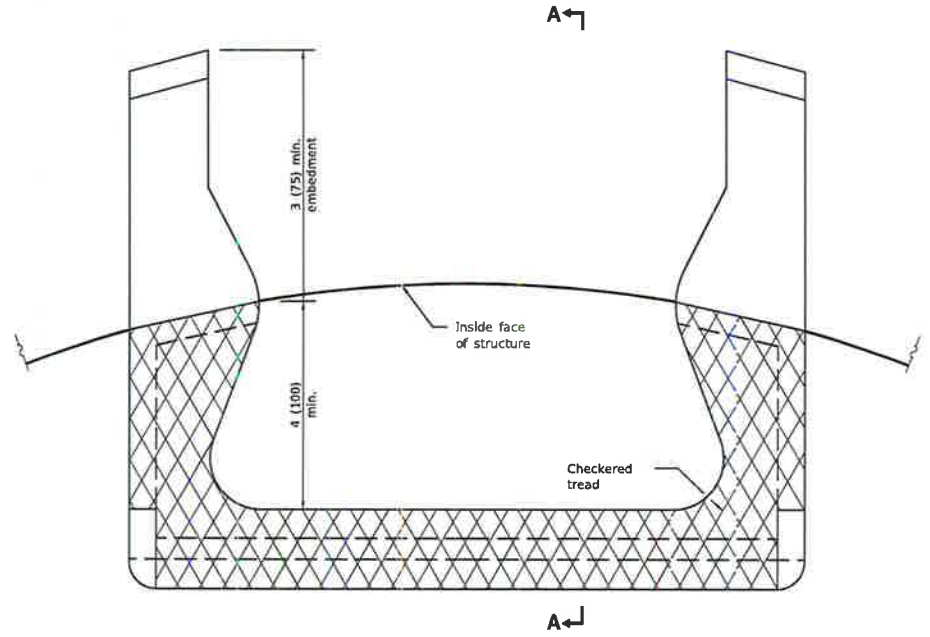

PLAN VIEW

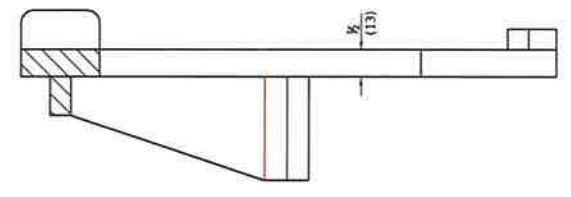

SECTION A-A

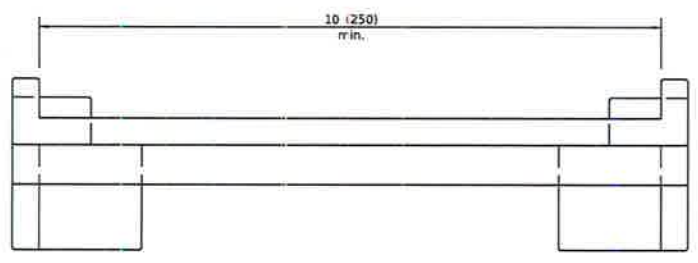

ELEVATION VIEW

All dimensions are in inches (millimeters) unless otherwise shown.

Illinois Department of Transportation

PASSED January 1, 2009
 ENGINEER OF POLICY AND PROCEDURES

APPROVED January 1, 2009
 ENGINEER OF DESIGN AND ENVIRONMENT

ISSUED 1-1-97

DATE	REVISIONS
1-1-09	Switched units to English (metric).
4-1-06	Revised title, drawings, and added plastic steps on sheet 2.

MANHOLE STEPS

(Sheet 1 of 2)

STANDARD 602701-02

PLASTIC STEPS

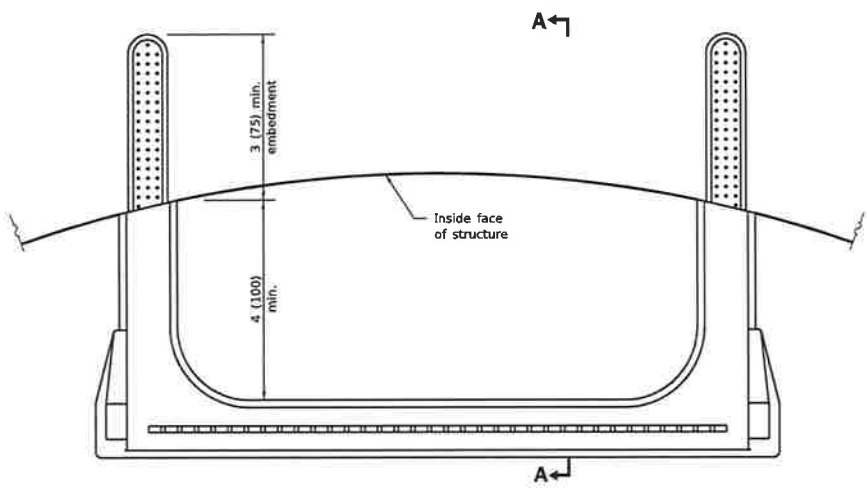

PLAN VIEW

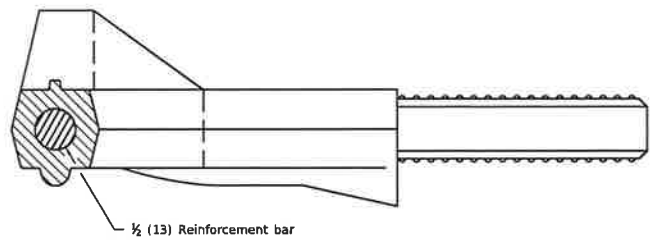

SECTION A-A

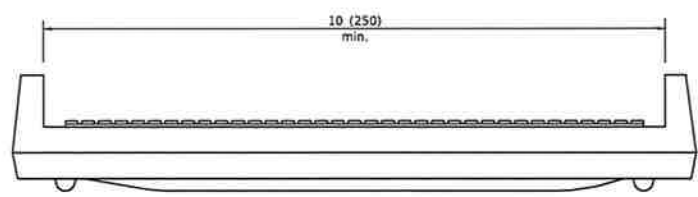

ELEVATION VIEW

Illinois Department of Transportation

PASSED	January 1, 2009
ENGINEER OF POLICY AND PROCEDURES	<i>[Signature]</i>
APPROVED	January 1, 2009
ENGINEER OF DESIGN AND ENVIRONMENT	<i>[Signature]</i>

ISSUED 1-1-09

MANHOLE STEPS

(Sheet 2 of 2)

STANDARD 602701-02

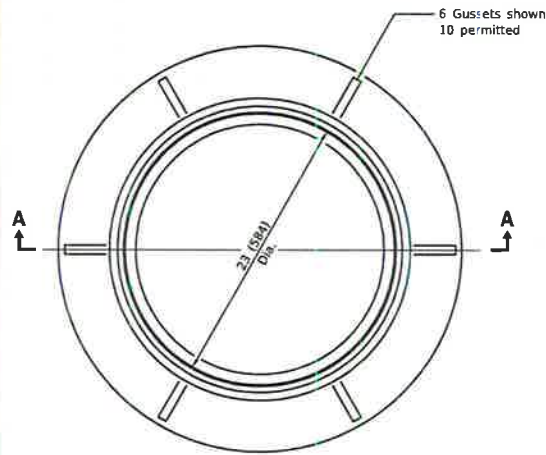

CAST FRAME

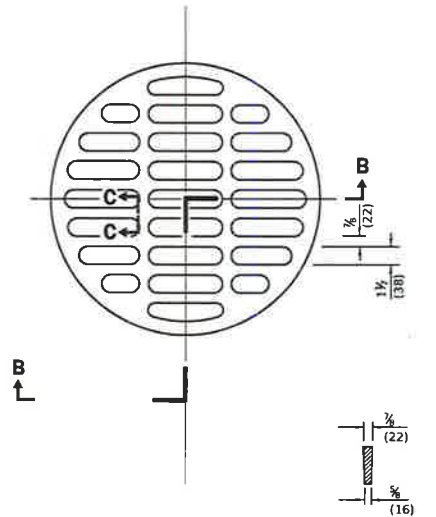

SECTION C-C

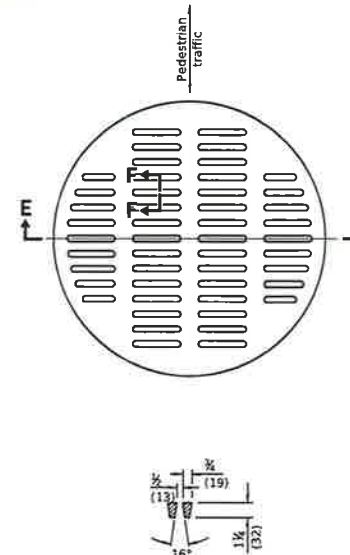

SECTION F-F

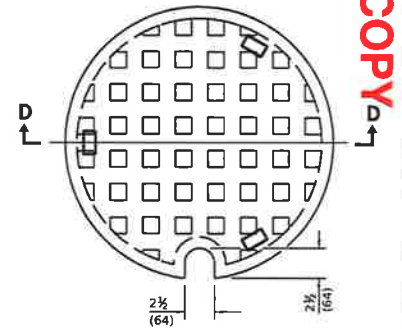

SECTION D-D

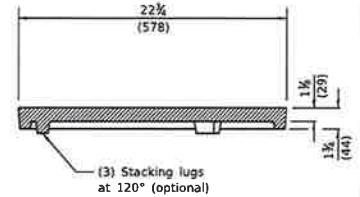

CAST CLOSED LID

Gray Iron Lid

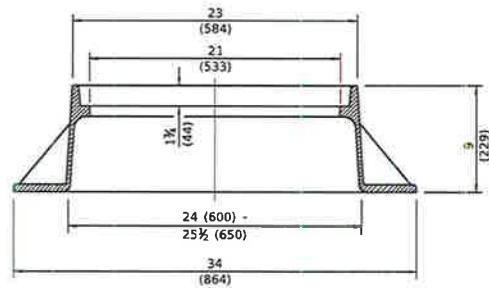

SECTION A-A

Gray Iron

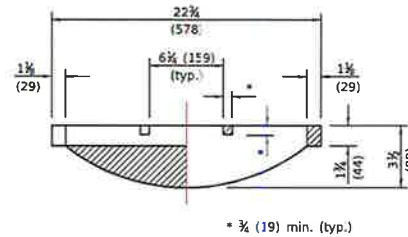

SECTION B-B

CAST OPEN LID

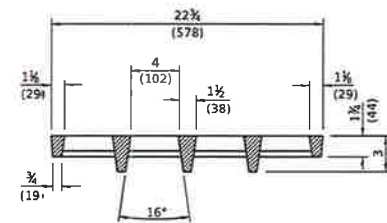

SECTION E-E

**ADA COMPLIANT
CAST OPEN LID**

All dimensions are in inches (millimeters) unless otherwise shown.

DATE	REVISIONS
1-1-20	Revised dimension in Section B-B of cast open lid.
1-1-15	Revised dimensioning of frame. Added ADA compliant open lid.
1-1-09	Switched units to English (metric).

**FRAME AND LIDS
TYPE 1**

STANDARD 604001-05

Illinois Department of Transportation

PASSED January 3, 2020
Michael Bond
 ENGINEER OF POLICY AND PROCEDURES

APPROVED January 3, 2020
John P. ...
 ENGINEER OF DESIGN AND ENVIRONMENT

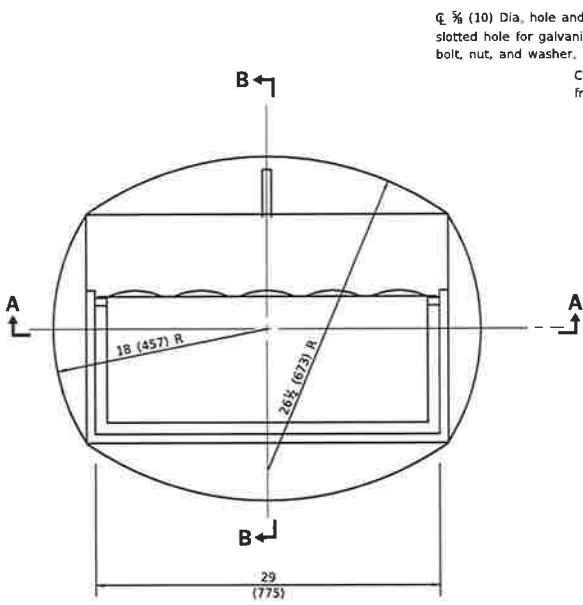

CAST FRAME

Ø 3/8 (10) Dia. hole and 3/8x5 1/2 (16x140) slotted hole for galvanized 1/2 (M12) bolt, nut, and washer.

Curb box adjustable from 4 1/2 (115) to 9 (225)

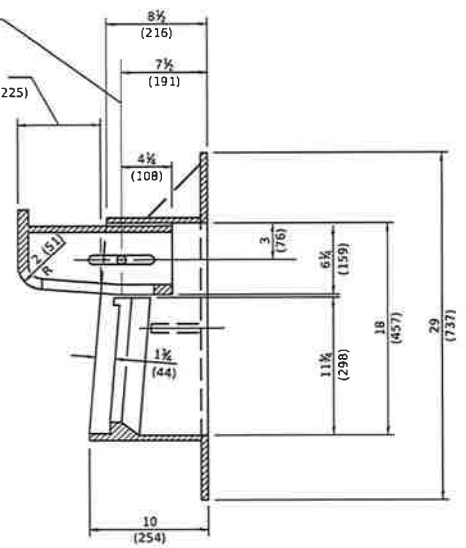

SECTION B-B

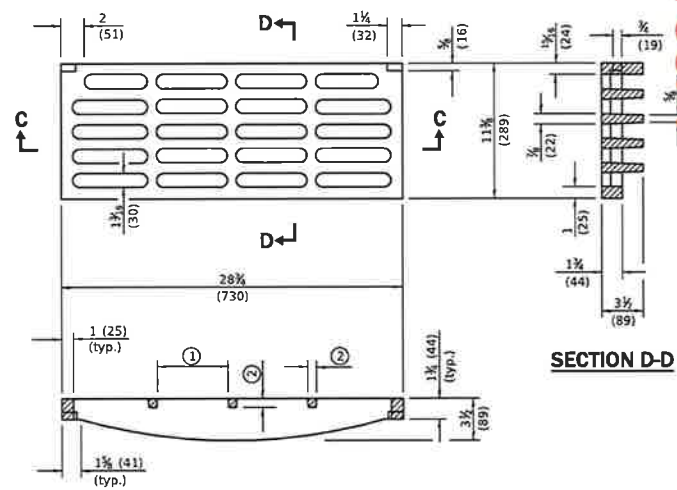

SECTION C-C

SECTION D-D

- ① = 6 1/2 (159) max. (typ.)
- ② = 3/8 (19) min. (typ.)

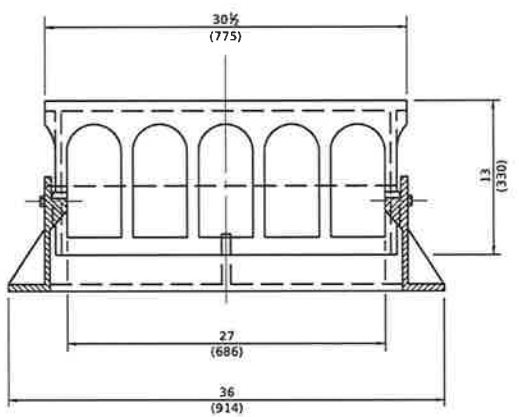

SECTION A-A

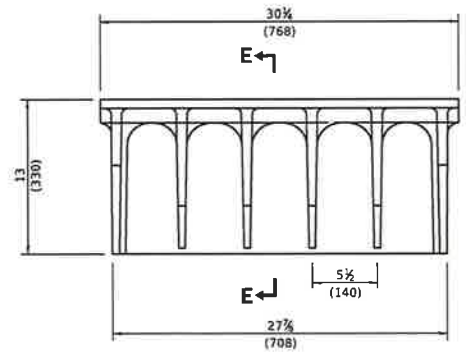

ALTERNATE CURB BOX

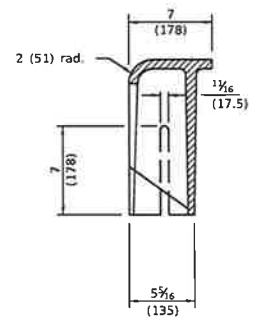

SECTION E-E

CAST GRATE

All dimensions are in inches (millimeters) unless otherwise shown.

Illinois Department of Transportation

PASSED January 1, 2015
Michael Brand
 ENGINEER OF POLICY AND PROCEDURES

APPROVED January 1, 2015
[Signature]
 ENGINEER OF DESIGN AND ENVIRONMENT

ISSUED 1-1-15

DATE	REVISIONS
1-1-15	Revised dimensions of frame and alternate curb box.
4-1-09	Switched units to English (metric).

**FRAME AND GRATE
TYPE 11**

STANDARD 604051-04

∅ $\frac{3}{8}$ (∅) Dia. hole and $\frac{3}{8}$ x $\frac{1}{2}$ (16x140) slotted hole for galvanized $\frac{1}{2}$ (M12) bolt, nut, and washer.

Curb box adjustable from $4\frac{1}{2}$ (115) to 9 (225)

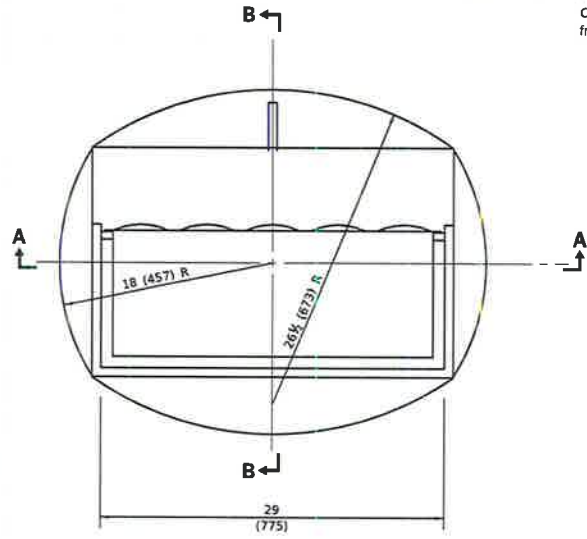

CAST FRAME

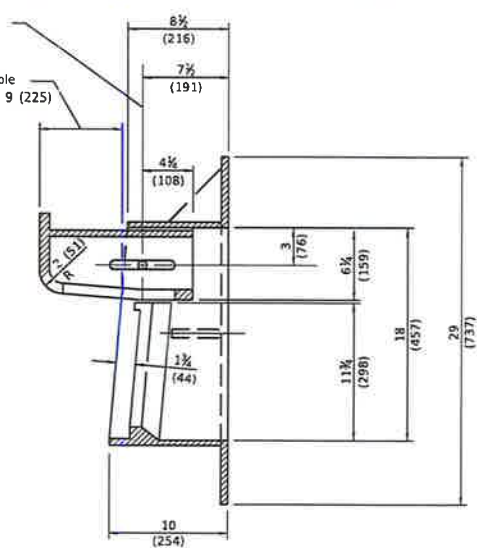

SECTION B-B

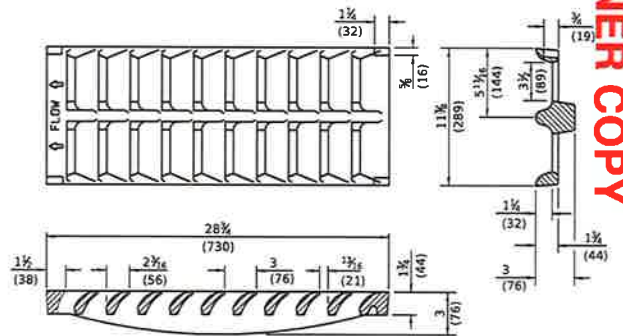

CAST GRATE

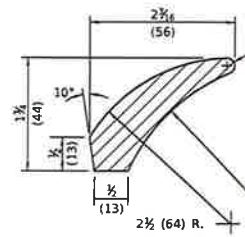

VANE DETAIL

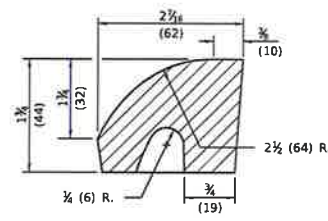

FRONT VANE DETAIL

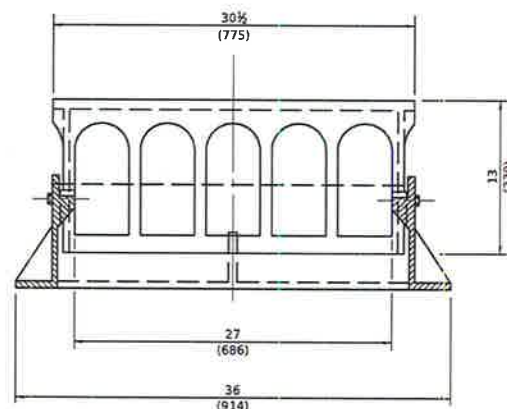

SECTION A-A

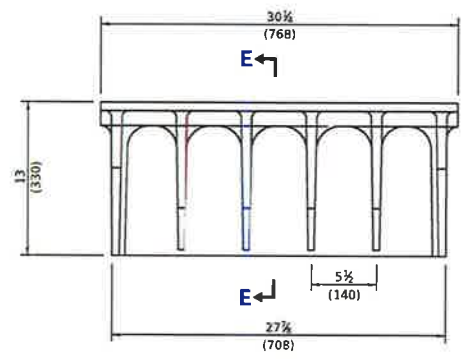

ALTERNATE CURB BOX

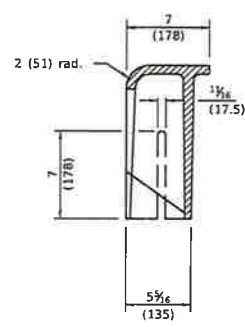

SECTION E-E

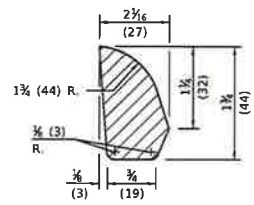

SIDE RIB DETAIL

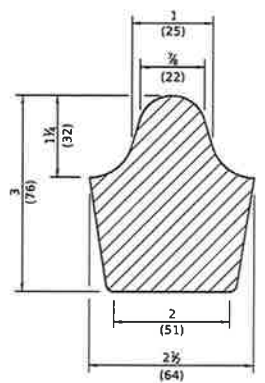

MIDDLE RIB DETAIL

All dimensions are in Inches (millimeters) unless otherwise shown.

Illinois Department of Transportation

PASSED JANUARY 3, 2015

Michael Brand
ENGINEER OF POLICY AND PROCEDURES

APPROVED FEBRUARY 1, 2015

[Signature]
ENGINEER OF DESIGN AND ENVIRONMENT

4811 01/15

DATE	REVISIONS
1-1-15	Revised dimensions of frame and alternate curb box.
1-1-09	Switched units to English (metric).

**FRAME AND GRATE
TYPE 11V**

STANDARD 604056-04

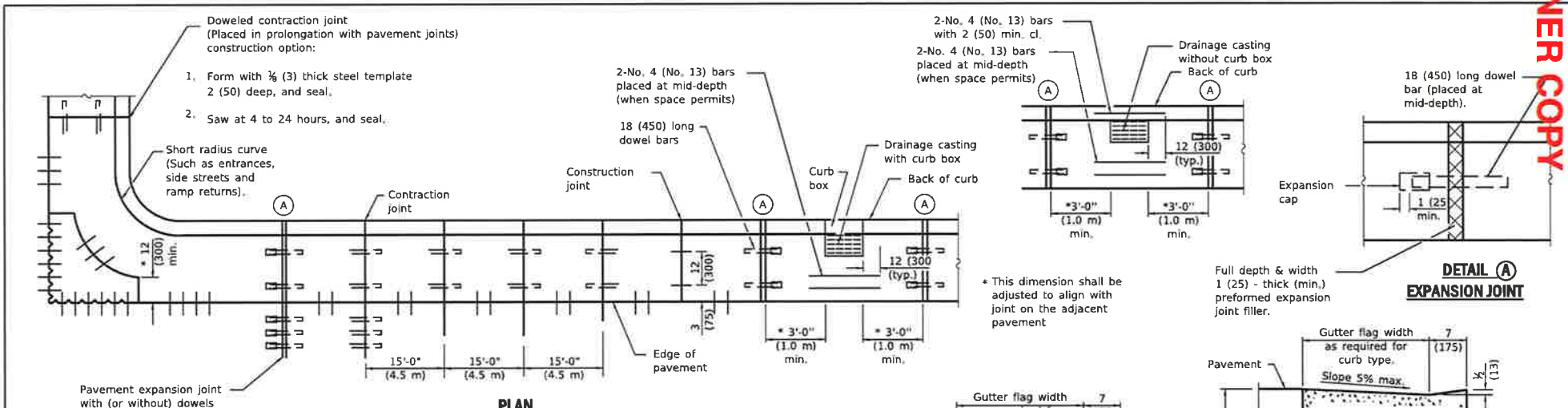

PLAN
ADJACENT TO PCC PAVEMENT OR PCC BASE COURSE

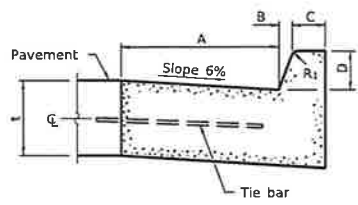

BARRIER CURB

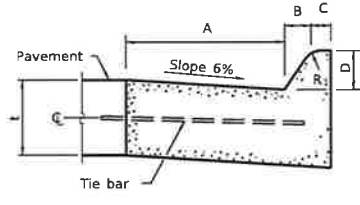

MOUNTABLE CURB

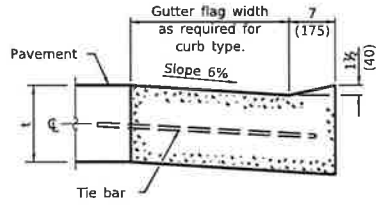

DEPRESSED CURB (TYPICAL)

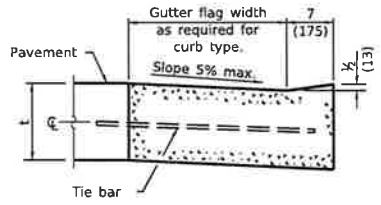

DEPRESSED CURB ADJACENT TO CURB RAMP ACCESSIBLE TO THE DISABLED

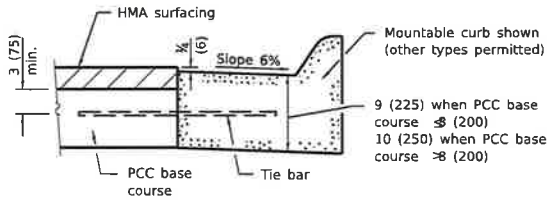

ADJACENT TO PCC BASE COURSE WITH HMA SURFACING

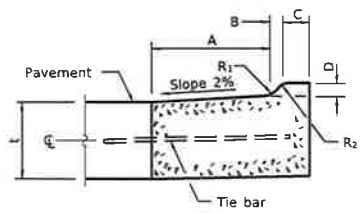

M-2.06 (M-5.15) and M-2.12 (M-5.30)

TABLE OF DIMENSIONS BARRIER CURB					
TYPE	A	B	C	D	R ₁
B-6.06 *	6	1	6	6	1
(B-15.15)	(150)	(25)	(150)	(150)	(25)
B-6.12	12	1	6	6	1
(B-15.3)	(300)	(25)	(150)	(150)	(25)
B-6.18	18	1	6	6	1
(B-15.45)	(450)	(25)	(150)	(150)	(25)
B-6.24	24	1	6	6	1
(B-15.60)	(600)	(25)	(150)	(150)	(25)
B-9.12	12	2	5	9	1
(B-22.30)	(300)	(50)	(125)	(225)	(25)
B-9.18	18	2	5	9	1
(B-22.45)	(450)	(50)	(125)	(225)	(25)
B-9.24	24	2	5	9	1
(B-22.60)	(600)	(50)	(125)	(225)	(25)

* For corner islands only.

TABLE OF DIMENSIONS MOUNTABLE CURB							
TYPE	A	B	C	D	R ₁	R ₂	
M-2.06	6	2	4	2	3	2	
(M-5.15)	(150)	(50)	(100)	(50)	(75)	(50)	
M-2.12	12	2	4	2	3	2	
(M-5.30)	(300)	(50)	(100)	(50)	(75)	(50)	
M-4.06	6	4	3	4	3	NA	
(M-10.15)	(150)	(100)	(75)	(100)	(75)	NA	
M-4.12	12	4	3	4	3	NA	
(M-10.30)	(300)	(100)	(75)	(100)	(75)	NA	
M-4.18	18	4	3	4	3	NA	
(M-10.45)	(450)	(100)	(75)	(100)	(75)	NA	
M-4.24	24	4	3	4	3	NA	
(M-10.60)	(600)	(100)	(75)	(100)	(75)	NA	
M-6.06	6	6	2	6	2	NA	
(M-15.15)	(150)	(150)	(50)	(150)	(50)	NA	
M-6.12	12	6	2	6	2	NA	
(M-15.30)	(300)	(150)	(50)	(150)	(50)	NA	
M-6.18	18	6	2	6	2	NA	
(M-15.45)	(450)	(150)	(50)	(150)	(50)	NA	
M-6.24	24	6	2	6	2	NA	
(M-15.60)	(600)	(150)	(50)	(150)	(50)	NA	

Full depth & width 1 (25) - thick (min.) preformed expansion joint filler.

DETAIL A
EXPANSION JOINT

GENERAL NOTES

The bottom slope of combination curb and gutter constructed adjacent to pcc pavement shall be the same slope as the subbase or 6% when subbase is omitted.

t = Thickness of pavement.

Longitudinal joint tie bars shall be No. 6 (No. 19) at 36 (900) centers in accordance with details for longitudinal construction joint shown on Standard 420001.

A minimum clearance of 2 (50) between the end of the tie bar and the back of the curb shall be maintained.

The dowel bars shown in contraction joints will only be required for monolithic construction.

See Standard 606301 for details of corner islands.

All dimensions are in inches (millimeters) unless otherwise shown.

DATE	REVISIONS
1-1-18	Revised General Note for tie bar spacing to 36 (900) cts.
1-1-15	Added B-6.06 (B-15.15) barrier curb and gutter to table (corner islands only).

CONCRETE CURB TYPE B AND COMBINATION CONCRETE CURB AND GUTTER

(Sheet 1 of 2)

STANDARD 606001-07

Illinois Department of Transportation

PASSED January 3, 2018

Michael Brand
ENGINEER OF POLICY AND PROCEDURES

APPROVED January 3, 2018

Matthew R. Patten
ENGINEER OF DESIGN AND ENVIRONMENT

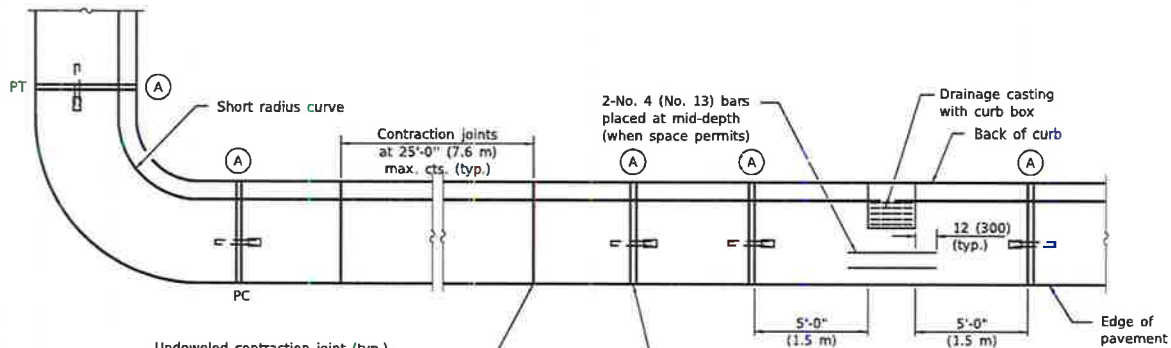

Undoweled contraction joint (typ.) construction options:

1. Form with 3/8 (3) thick steel template 2 (50) deep, and seal.
2. Saw 2 (50) deep at 4 to 24 hours, and seal.
3. Insert 3/8 (20) thick preformed joint filler full depth and width.

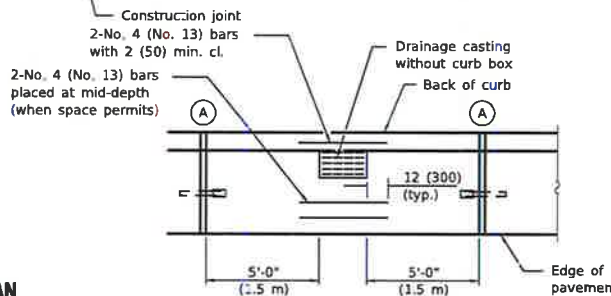

PLAN

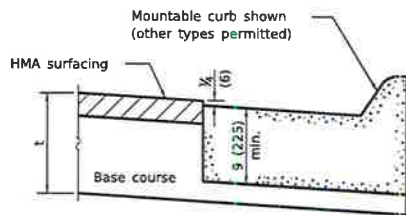

ON DISTURBED SUBGRADE

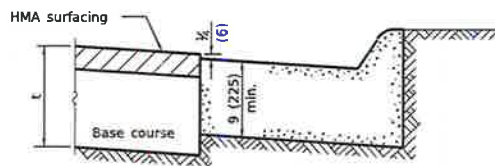

ON UNDISTURBED SUBGRADE

ADJACENT TO FLEXIBLE PAVEMENT

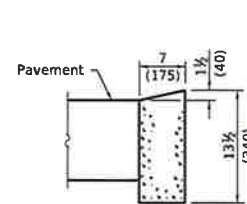

DEPRESSED CURB

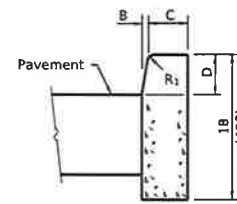

BARRIER CURB

ADJACENT TO FLEXIBLE PAVEMENT

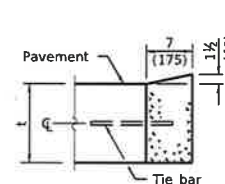

DEPRESSED CURB

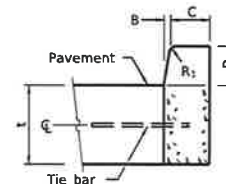

BARRIER CURB

ADJACENT TO PCC PAVEMENT OR PCC BASE COURSE

CONCRETE CURB TYPE B

**CONCRETE CURB TYPE B
AND COMBINATION
CONCRETE CURB AND GUTTER**

(Sheet 2 of 2)

STANDARD 606001-07

Illinois Department of Transportation

PASSED: January 1, 2018

APPROVED: January 1, 2018

ENGINEER OF POLICY AND PROCEDURES

ENGINEER OF DESIGN AND ENVIRONMENT

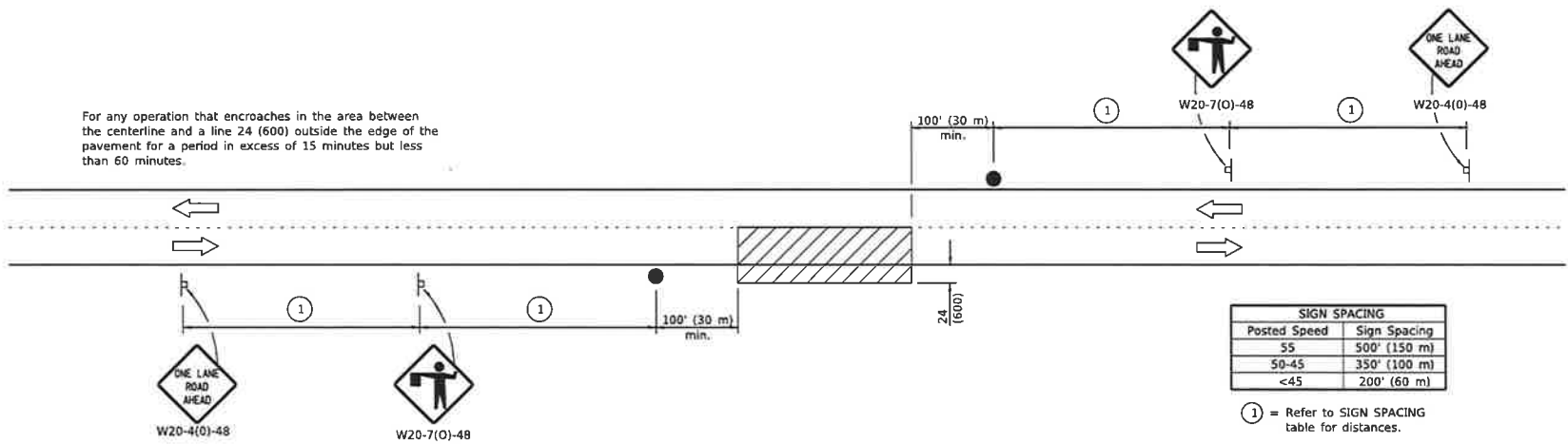
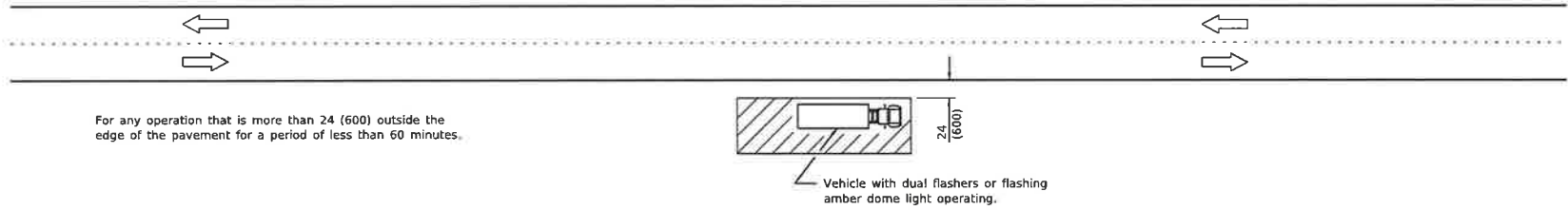
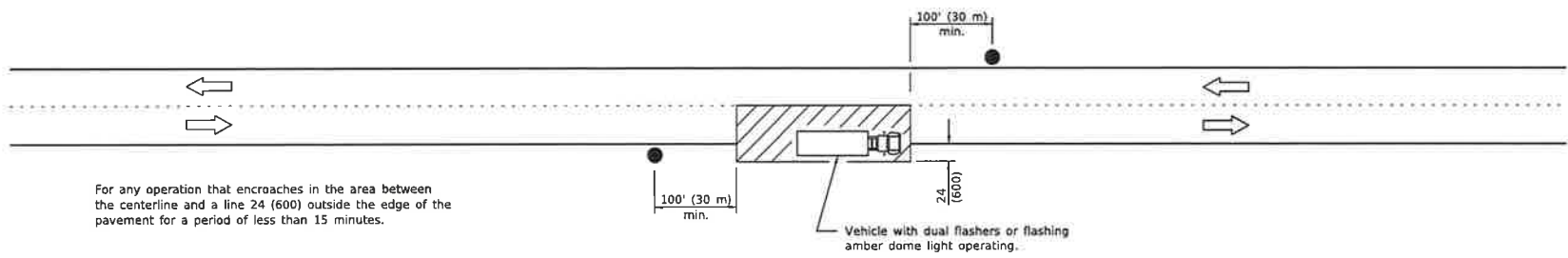

TYPICAL APPLICATIONS

- Marking patches
- Field survey
- String line
- Utility operations
- Cleaning up debris on pavement

SYMBOLS

- Work area
- Sign on portable or permanent support
- Flagger with traffic control sign

All dimensions are in inches (millimeters) unless otherwise shown.

Illinois Department of Transportation

PASSED January 1, 2011

ENGINEER OF SAFETY ENGINEERING

APPROVED January 1, 2011

ENGINEER OF DESIGN AND ENVIRONMENT

SOURCE 1-197

DATE	REVISIONS
1-1-11	Revised flagger sign.
1-1-09	Switched units to English (metric).

**LANE CLOSURE, 2L, 2W,
SHORT TIME OPERATIONS**

STANDARD 701301-04

CONTRACT

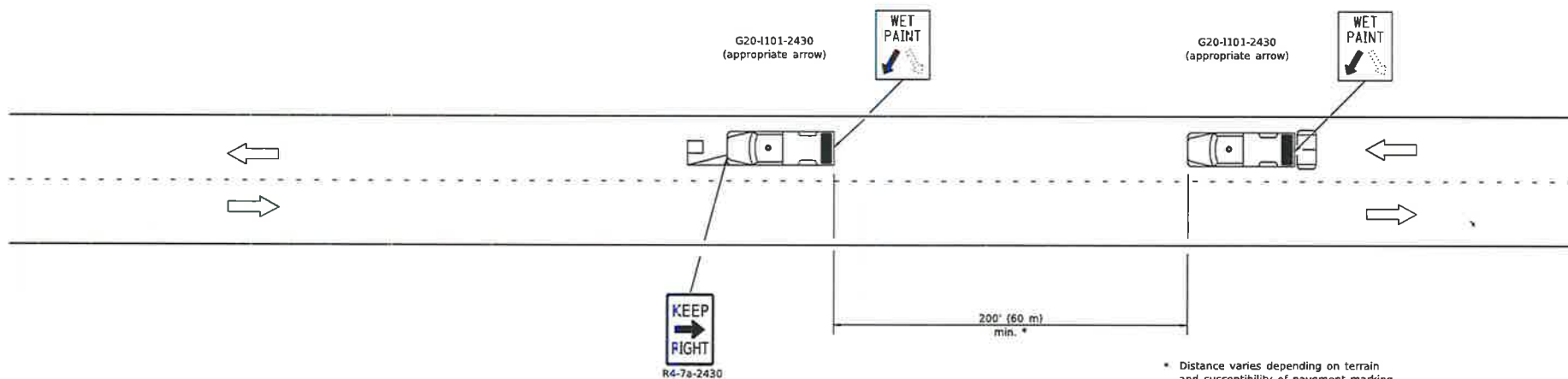





* Distance varies depending on terrain and susceptibility of pavement marking or crack sealant to wheel tracking.

TYPICAL APPLICATIONS

- Landscaping work
- Utility work
- Pavement marking
- Weed spraying
- Roadometer measurements
- Debris cleanup
- Crack pouring

SYMBOLS

-  Arrow board (Hazard Mode only)
-  Truck with headlights, emergency flashers and flashing amber light. (visible from all directions)
-  18x18 (450x450) min. orange flag (use when guide wheel is used)
-  Truck mounted attenuator

GENERAL NOTES

This Standard is used where any vehicle, equipment, workers or their activities will require a continuous moving operation where the average speed is greater than 3 mph (5 km/h).

For shoulder operations not encroaching on the pavement, use DETAIL A, Standard 701426.

All dimensions are in inches (millimeters) unless otherwise shown.

DATE	REVISIONS
1-1-09	Switched units to English (metric). Omitted Pass With Care sign.
1-1-00	Elim. speed restrictions in Standard title.

**LANE CLOSURE 2L, 2W
MOVING OPERATIONS-
DAY ONLY**

STANDARD 701311-03

Illinois Department of Transportation





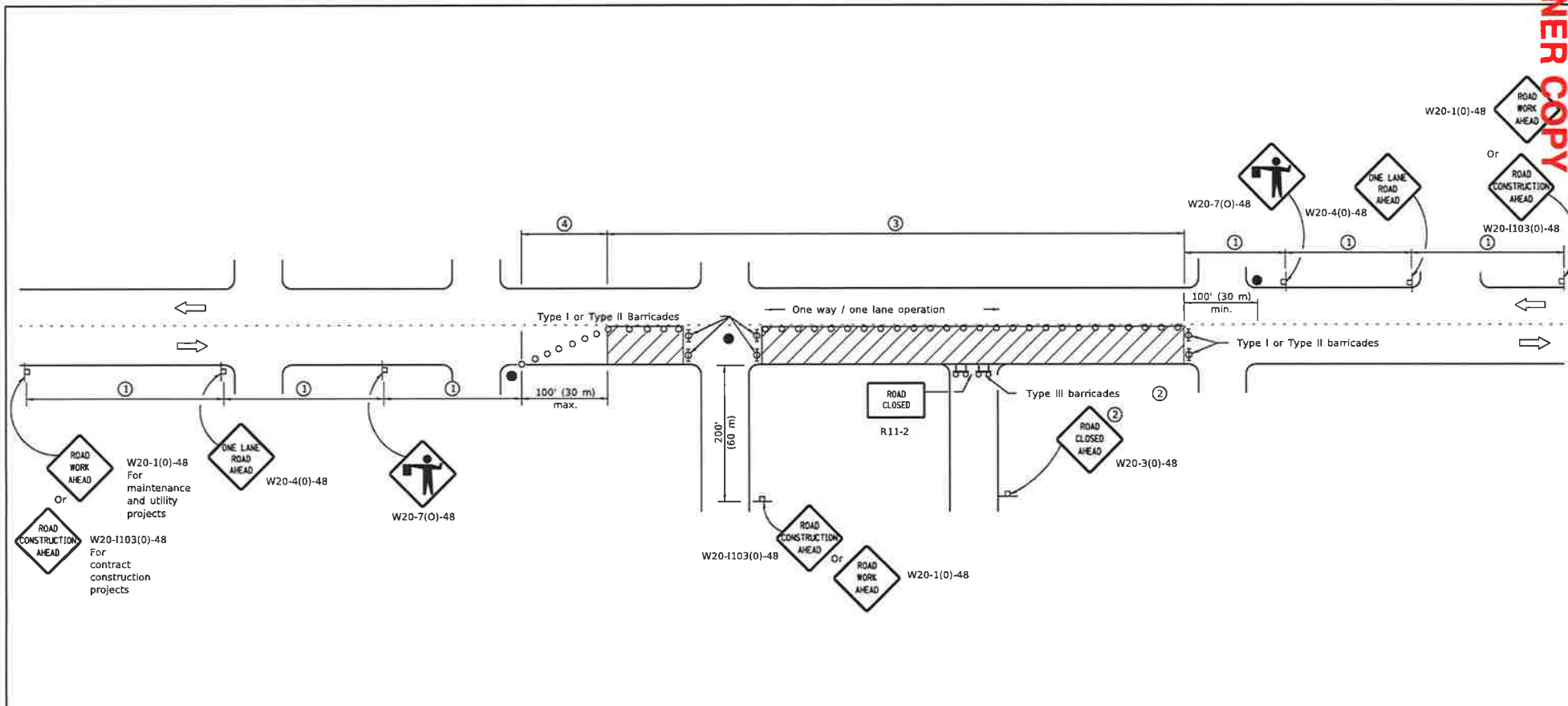

PASSED: January 2, 2009
 ENGINEER OF OPERATIONS
 APPROVED: January 2, 2009
 ENGINEER OF DESIGN AND ENVIRONMENT

ISSUED 1-1-87



SIGN SPACING	
Posted Speed	Sign Spacing
55	500' (150 m)
50-45	350' (100 m)
<45	200' (60 m)

SYMBOLS

-  Work area
-  Cone, drum or barricade (not required for moving operations)
-  Sign on portable or permanent support
-  Flagger with traffic control sign
-  Barricade or drum with flashing light
-  Type III barricade with flashing lights

- ① Refer to SIGN SPACING TABLE for distances.
- ② For approved sideroad closures.
- ③ Cones at 25' (8 m) centers for 250' (75 m). Additional cones may be placed at 50' (15 m) centers. When drums or Type I or Type II barricades are used, the interval between devices may be doubled.
- ④ Cones, drums or barricades at 20' (6 m) centers.

GENERAL NOTES

This Standard is used where at any time, day or night, any vehicle, equipment, workers or their activities encroach on the pavement requiring the closure of one traffic lane in an urban area.

All dimensions are in inches (millimeters) unless otherwise shown.

Illinois Department of Transportation

PASSED January 3, 2011
 ENGINEER OF SAFETY ENGINEERING

APPROVED January 3, 2011
 ENGINEER OF DESIGN AND ENVIRONMENT

SDS&S 1-1-07

DATE	REVISIONS
1-1-11	Revised flagger sign.
1-1-09	Switched units to English (metric). Corrected sign No.'s.

**URBAN LANE CLOSURE,
2L, 2W, UNDIVIDED**

STANDARD 701501-06

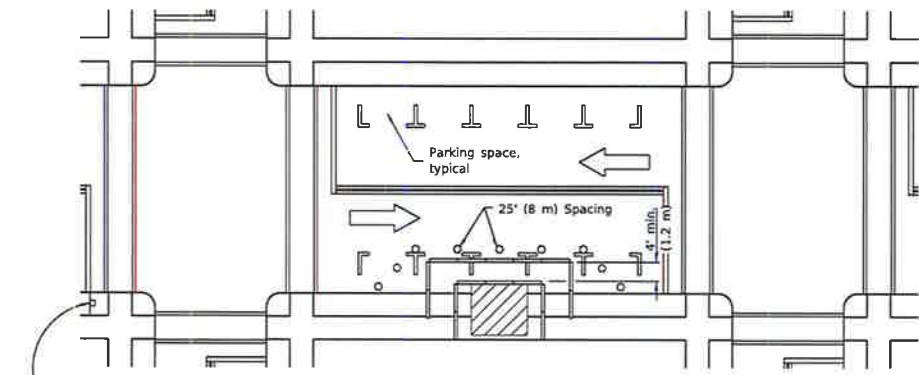

① ROAD CONSTRUCTION AHEAD
W20-1103(0)-48 for contract construction projects

Or

① ROAD WORK AHEAD
W20-1(0)-48 for maintenance and utility projects

SIDEWALK DIVERSION

- SYMBOLS**
- Work area
 - Sign on portable or permanent support
 - Barricade or drum
 - Cone, drum or barricade
 - Type III barricade
 - Detectable pedestrian channelizing barricade

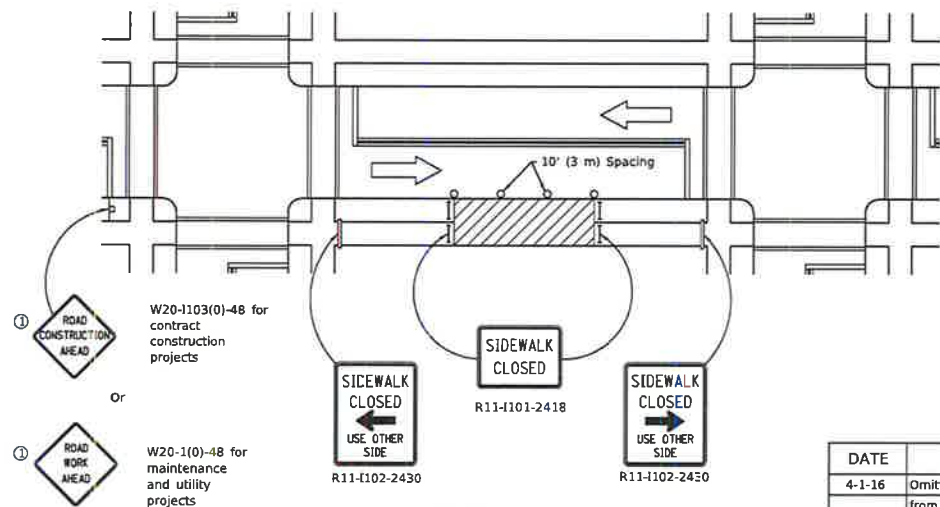

① ROAD CONSTRUCTION AHEAD
W20-1103(0)-48 for contract construction projects

Or

① ROAD WORK AHEAD
W20-1(0)-48 for maintenance and utility projects

SIDEWALK CLOSURE

① Omit whenever duplicated by road work traffic control.

GENERAL NOTES

This Standard is used where, at any time, pedestrian traffic must be rerouted due to work being performed.

This Standard must be used in conjunction with other Traffic Control & Protection Standards when roadway traffic is affected.

Temporary facilities shall be detectable and accessible.

The temporary pedestrian facilities shall be provided on the same side of the closed facilities whenever possible.

The SIDEWALK CLOSED / USE OTHER SIDE sign shall be placed at the nearest crosswalk or intersection to each end of the closure. Where the closure occurs at a corner, the signs shall be erected on the corners across the street from the closure. The SIDEWALK CLOSED signs shall be used at the ends of the actual closures.

Type III barricades and R11-2-4830 signs shall be positioned as shown in "ROAD CLOSED TO ALL TRAFFIC" detail on Standard 701901.

All dimensions are in inches (millimeters) unless otherwise shown.

Illinois Department of Transportation

PASSED: April 2, 2016
ENGINEER OF SAFETY ENGINEERING

APPROVED: April 2, 2016
ENGINEER OF DESIGN AND ENVIRONMENT

ISSUED: 1-1-97

DATE	REVISIONS
4-1-16	Omitted orange safety fence from standard as this is covered in the std. spec.
1-1-12	Added SIDEWALK DIVERSION. Modified appearance of plan views. Renamed Std.

SIDEWALK, CORNER OR CROSSWALK CLOSURE

(Sheet 1 of 2)

STANDARD 701801-06

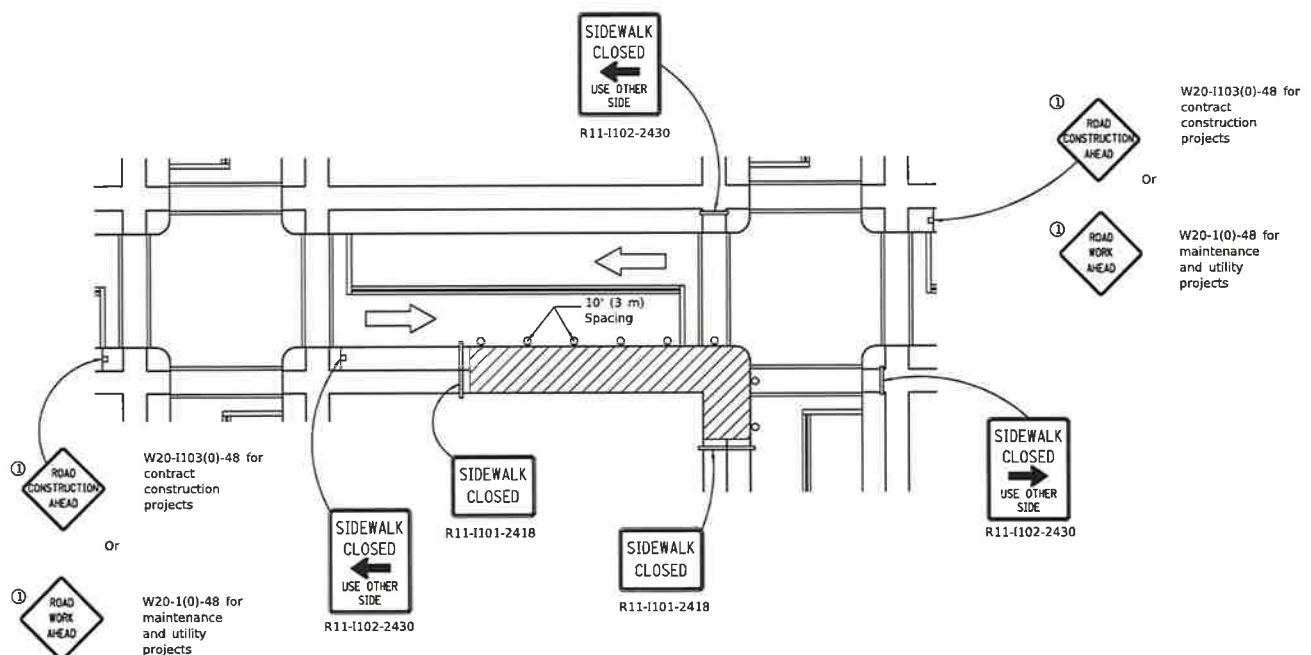

CORNER CLOSURE

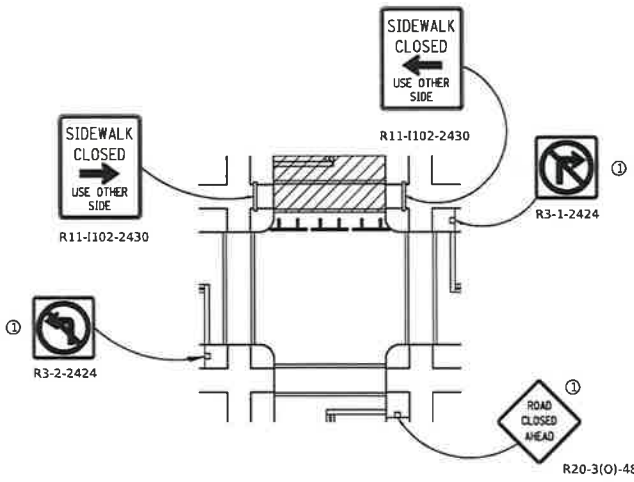

CROSSWALK CLOSURE

Illinois Department of Transportation

PASSED	April 1, 2016	ISSUED 1-1-97
APPROVED	April 1, 2016	

ENGINEER OF DESIGN AND ENVIRONMENT

SIDEWALK, CORNER OR CROSSWALK CLOSURE

(Sheet 2 of 2)

STANDARD 701801-06

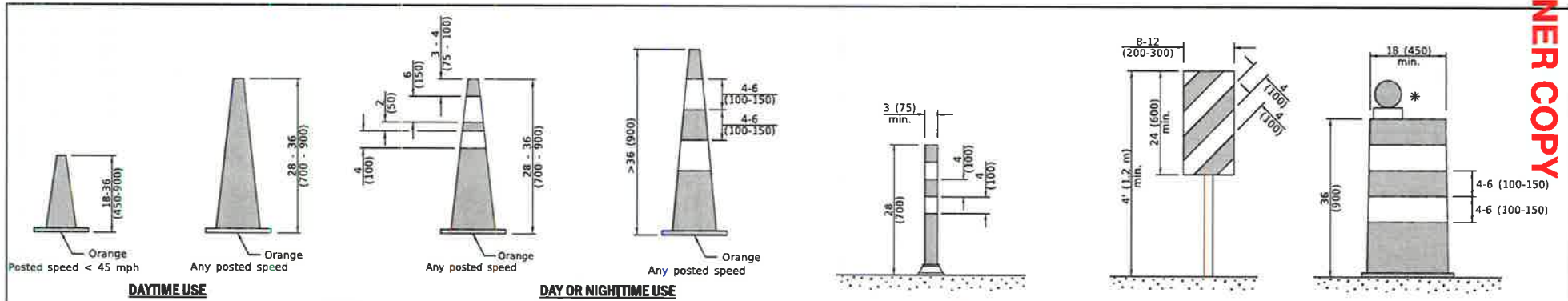

CONES

TUBULAR MARKER

VERTICAL PANEL
POST MOUNTED

DRUM

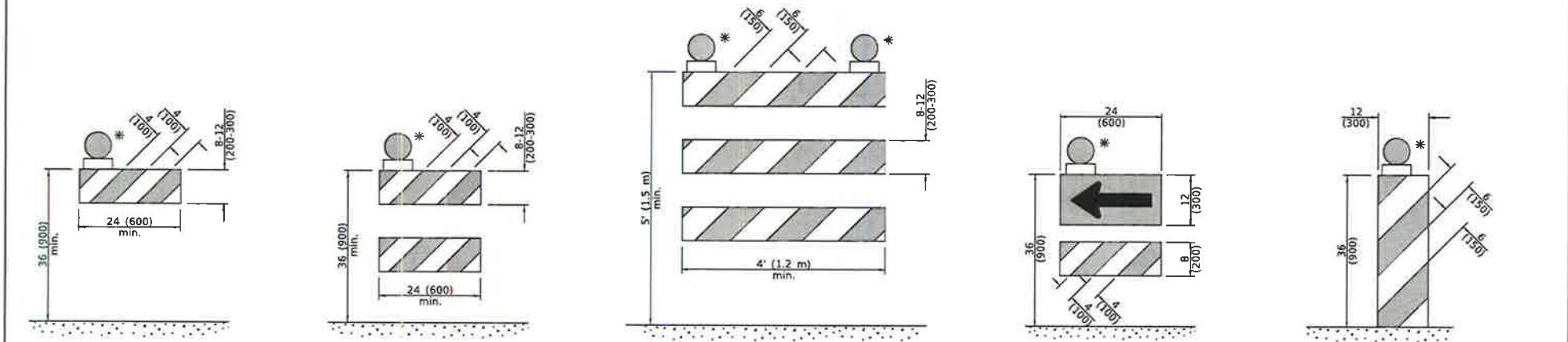

TYPE I BARRICADE

TYPE II BARRICADE

TYPE III BARRICADE

DIRECTION INDICATOR BARRICADE

VERTICAL BARRICADE

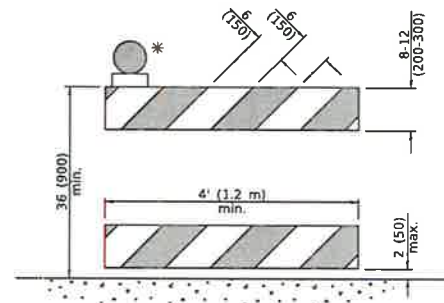

* Warning lights (if required)

GENERAL NOTES

All heights shown shall be measured above the pavement surface.
 All dimensions are in inches (millimeters) unless otherwise shown.

Illinois Department of Transportation

APPROVED January 1, 2019
 ENGINEER OF SAFETY PROG AND ENGINEERING

APPROVED January 1, 2019
 ENGINEER OF DESIGN AND ENVIRONMENT

DATE	REVISIONS
1-1-19	Revised cone usage and added cones >36" (900 m) height.
1-1-18	Revised END WORK ZONE SPEED LIMIT sign from orange to white background.

TRAFFIC CONTROL DEVICES

STANDARD 701901-08

(Sheet 1 of 3)

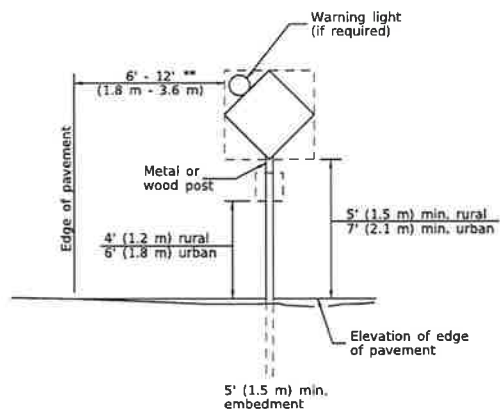

POST MOUNTED SIGNS

** When curb or paved shoulder are present this dimension shall be 24 (600) to the face of curb or 6' (1.8 m) to the outside edge of the paved shoulder.

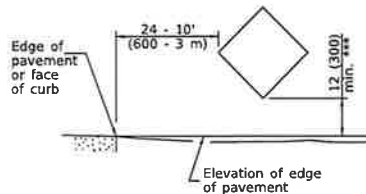

SIGNS ON TEMPORARY SUPPORTS

*** When work operations exceed four days, this dimension shall be 5' (1.5 m) min. If located behind other devices, the height shall be sufficient to be seen completely above the devices.

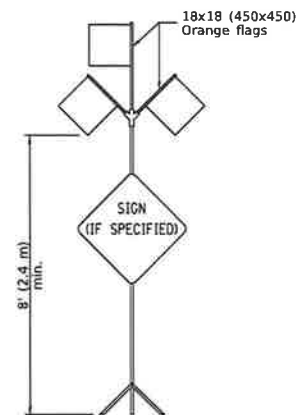

HIGH LEVEL WARNING DEVICE

ROAD
CONSTRUCTION
NEXT X MILES
G20-1104(0)-6036

END
CONSTRUCTION
G20-1105(0)-6024

This signing is required for all projects 2 miles (3200 m) or more in length.
ROAD CONSTRUCTION NEXT X MILES sign shall be placed 500' (150 m) in advance of project limits.
END CONSTRUCTION sign shall be erected at the end of the job unless another job is within 2 miles (3200 m).
Dual sign displays shall be utilized on multi-lane highways.

WORK LIMIT SIGNING



W12-1103-4848

WIDTH RESTRICTION SIGN

XX'-XX" width and X miles are variable.

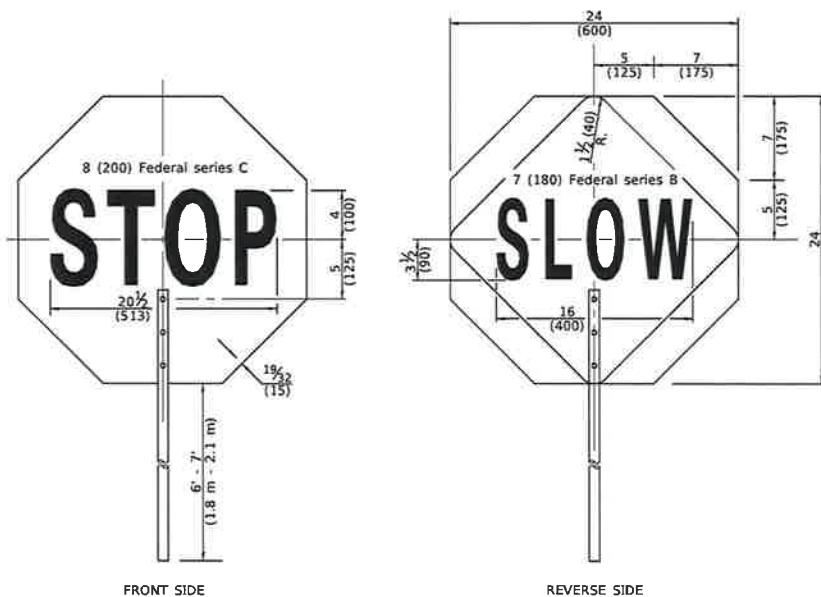

FRONT SIDE

REVERSE SIDE

FLAGGER TRAFFIC CONTROL SIGN



W21-1115(0)-3618

R2-1-3648

R10-1108p-3618 ****

R2-1106p-3618

Sign assembly as shown on Standards or as allowed by District Operations.

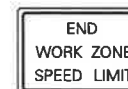

G20-1103-6036

This sign shall be used when the above sign assembly is used.

HIGHWAY CONSTRUCTION SPEED ZONE SIGNS

**** R10-1108p shall only be used along roadways under the jurisdiction of the State.

Illinois Department of Transportation

APPROVED JANUARY 1, 2019

 ENGINEER OF SAFETY PROG. AND ENGINEERING

APPROVED JANUARY 1, 2019

 ENGINEER OF DESIGN AND ENVIRONMENT

ST-1-1-3

TRAFFIC CONTROL DEVICES

(Sheet 2 of 3)

STANDARD 701901-08

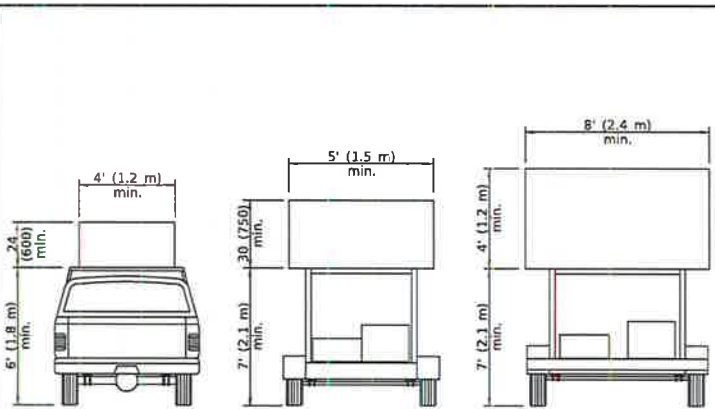

TYPE A ROOF MOUNTED
TYPE B ROOF OR TRAILER MOUNTED
TYPE C TRAILER MOUNTED

ARROW BOARDS

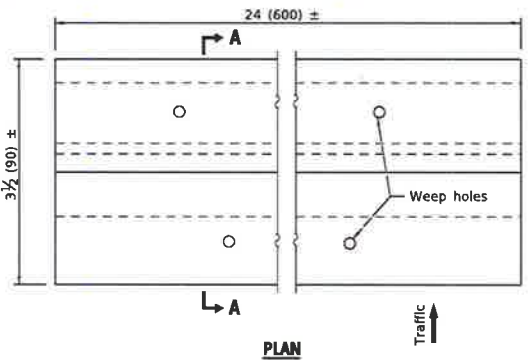

PLAN

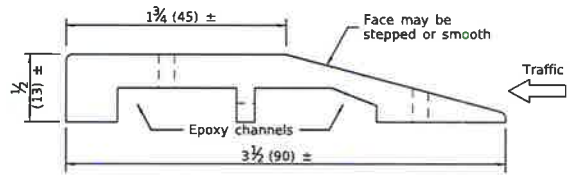

SECTION A-A

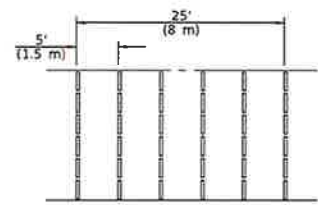
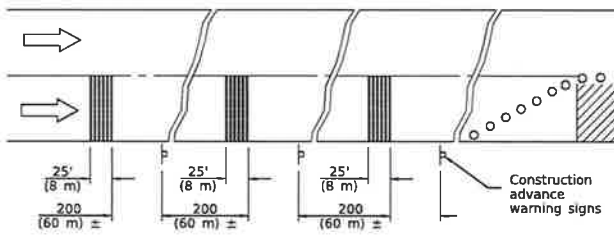

TYPICAL INSTALLATION

TEMPORARY RUMBLE STRIPS

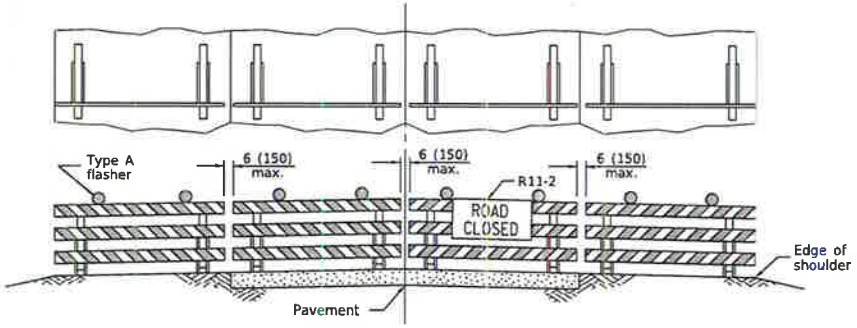

ROAD CLOSED TO ALL TRAFFIC

ReflectORIZED striping may be omitted on the back side of the barricades. If a Type III barricade with an attached sign panel which meets NCHRP 350 is not available, the sign may be mounted on an NCHRP 350 temporary sign support directly in front of the barricade.

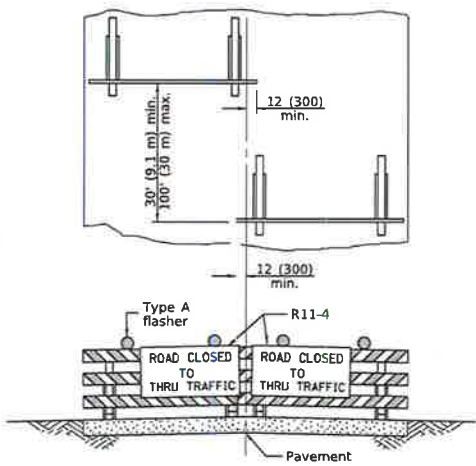

ROAD CLOSED TO THRU TRAFFIC

ReflectORIZED striping shall appear on both sides of the barricades. If a Type III barricade with an attached sign panel which meets NCHRP 350 is not available, the signs may be mounted on NCHRP 350 temporary sign supports directly in front of the barricade.

TYPICAL APPLICATIONS OF TYPE III BARRICADES CLOSING A ROAD

Illinois Department of Transportation

APPROVED January 3, 2019
 ENGINEER OF SAFETY PRAC. AND ENGINEERING

APPROVED January 3, 2019
 ENGINEER OF DESIGN AND ENVIRONMENT

ISSUED 11-11

TRAFFIC CONTROL DEVICES

STANDARD 701901-08

(Sheet 3 of 3)

Ordinance No. 3733**AN ORDINANCE OF THE VILLAGE OF VILLA PARK, DUPAGE COUNTY, ILLINOIS AMENDING THE REQUIREMENTS OF BIDDERS FOR CONSTRUCTION PROJECTS**

WHEREAS, the Village of Villa Park (the "*Village*") is a duly organized and validly existing non home-rule municipality created in accordance with the Constitution of the State of Illinois of 1970 and the laws of the State; and,

WHEREAS, section 8-9-1 of the Illinois Municipal Code (65 ILCS 5/8-9-2) allows the Village to require competitive bidding after advertising for bids in the manner prescribed by ordinance; and,

WHEREAS, the President and Board of Trustees desire to adopt purchasing procedures to provide for additional requirements of bidders for construction projects to have active apprenticeship and training programs approved and registered with the United States Department of Labor's Bureau of Apprenticeship and Training and to have bidders show three similar projects they constructed within the last five years.

NOW, THEREFORE, BE IT ORDAINED by the President and Board of Trustees of the Village of Villa Park, DuPage County, Illinois, as follows:

Section 1. That Section 2-219 of the Villa Park Municipal Code, as amended, be and is hereby amended by placing the existing text as subsection A. and adding a new subsection B. to read as follows:

"B. A responsible bidder for the construction of public works projects shall meet and submit evidence of compliance with the following requirements:

- (1) All applicable laws prerequisite to doing business in the State of Illinois,
- (2) A federal employer tax identification number or social security number,
- (3) Provision of Section 2000(e) of Chapter 21, Title 42 of the United States Code and Federal Executive Order No. 11246 as amended by Executive Order No. 11375 (known as the Equal Opportunity Employer provisions),
- (4) Certificates of insurance indicating the following coverage's: general liability, worker's compensation, completed operations, automobile, hazardous occupation and product liability
- (5) Compliance with all provisions of the Illinois Prevailing Wage Act, including wages, medical and hospitalization insurance and retirement for those trades covered in the Act,
- (6) The bidder and all bidder's sub-contractors must participate in active apprenticeship and training programs approved and registered with the United States Department of Labor's Bureau of Apprenticeship and Training for each of the trades of work contemplated under the proposed contract,
- (7) All contractors and sub-contractors are required to file certified payrolls as specified in Illinois Pubic Act 94-0515, and follow all provisions of the Employee Classification Act (820 ILCS 185/1 et seq.), and

(8) All bidders must provide three (3) projects of a similar nature constructed in the immediate past five (5) years with the name, address and telephone number of the contact person having knowledge of the project along with three (3) references (name, address, and telephone number) with knowledge of the integrity and business practices of the bidder.”

Section 2. This Ordinance shall be in full force and effect upon its passage, approval, and publication as provided by law.

Passed this 11 day of February, 2013.

AYES: ALL

NAYS: Aiello Bulhuis

ABSENT: _____

Approved this 11 day of February, 2013.



Village President

Attest:
Village Clerk



Published in pamphlet form:

2-11, 2013

**IRMA
CONTRACTUAL INSURANCE GUIDELINES**

I. INSURANCE REQUIREMENTS

Contractor shall procure and maintain, for the duration of the contract, insurance against claims for injuries to persons or damages to property, which may arise from or in connection with the performance of the work hereunder by the Contractor, his agents, representatives, employees or subcontractors.

MINIMUM SCOPE OF INSURANCE

Coverage shall be at least as broad as:

- A. Insurance Services Office Commercial General Liability occurrence form CG 0001 with the member named as additional insured, on a form at least as broad as the attached sample endorsement including ISO Additional Insured Endorsement CG 2010 (Exhibit A), CG 2026 (Exhibit B).

CG2037 - Completed Operations – (Exhibit C)

Required if box is checked ; and

- B. Owners and Contractors Protective Liability (OCP) policy with the member as insured

Required if box is checked ; and

- C. Insurance Service Office Business Auto Liability coverage form number CA 0001, Symbol 01 "Any Auto."

- D. Workers' Compensation as required by the Workers' Compensation Act of the State of Illinois and Employers' Liability insurance.

Coverage required for employee exposure to lead, if box is checked

- E. Builder Risk Property Coverage with member as loss payee

Required if box is checked .

- F. Environmental Impairment/Pollution Liability Coverage for pollution incidents as a result of a claim for bodily injury, property damage or remediation costs from an incident at, on or migrating beyond the contracted work site. Coverage shall be extended to Non-Owned Disposal sites resulting from a pollution incident at, on or mitigating beyond the site; and also provide coverage for incidents occurring during transportation of pollutants.

Required if box is checked .

MINIMUM LIMITS OF INSURANCE

Contractor shall maintain limits no less than the following, **if required under above scope**:

- A. Commercial General Liability: \$1,000,000 combined single limit per occurrence for bodily injury, and property damage and \$1,000,000 per occurrence for personal injury. The general aggregate shall be twice the required occurrence limit. Minimum General Aggregate shall be no less than \$2,000,000 or a project/contract specific aggregate of \$1,000,000.

- B. Owners and Contractors Protective Liability (OCP): \$1,000,000 combined single limit per occurrence for bodily injury and property damage.
- C. Business Automobile Liability: \$1,000,000 combined single limit per accident for bodily injury and property damage.
- D. Workers' Compensation and Employers' Liability: Workers' Compensation coverage with statutory limits and Employers' Liability limits of \$500,000 per accident.
- E. Builder's Risk: Shall insure against "All Risk" of physical damage, including water damage (flood and hydrostatic pressure not excluded), on a completed replacement cost basis.
- F. Environmental Impairment/Pollution Liability: \$1,000,000 combined single limit per occurrence for bodily injury, property damage and remediation costs.

DEDUCTIBLES AND SELF-INSURED RETENTIONS

Any deductibles or self-insured retentions must be declared to and approved by the member. At the option of the member, either: the insurer shall reduce or eliminate such deductibles or self-insured retentions as respects the member, its officials, employees, agents and volunteers; or the Contractor shall procure a bond guaranteeing payment of losses and related investigation, claim administration and defense expenses.

OTHER INSURANCE PROVISIONS

The policies are to contain, or be endorsed to contain, the following provisions:

A. General Liability and Automobile Liability Coverages

1. The member, its officials, agents, employees and volunteers are to be covered as additional insureds as respects: liability arising out of the Contractor's work, including activities performed by or on behalf of the Contractor; products and completed operations of the Contractor; premises owned, leased or used by the Contractor; or automobiles owned, leased, hired or borrowed by the Contractor. The coverage shall contain no special limitations on the scope of protection afforded to the member, its officials, agents, employees and volunteers.
2. The Contractor's insurance coverage shall be primary as respects the member, its officials, employees, agents and volunteers. Any insurance or self-insurance maintained by the member, its officials, agents, employees and volunteers shall be excess of Contractor's insurance and shall not contribute with it.
3. Any failure to comply with reporting provisions of the policies shall not affect coverage provided to the member, its officials, employees, agents and volunteers.
4. The Contractor's insurance shall contain a Severability of Interests/Cross Liability clause or language stating that Contractor's insurance shall apply separately to each insured against whom claim is made or suit is brought, except with respect to the limits of the insurer's liability.
5. If any commercial general liability insurance is being provided under an excess

or umbrella liability policy that does not "follow form," then the Contractor shall be required to name the member, its officials, employees, agents and volunteers as additional insureds.

6. All general liability coverages shall be provided on an occurrence policy form. Claims-made general liability policies will not be accepted.
7. The contractor and all subcontractors hereby agree to waive any limitation as to the amount of contribution recoverable against them by member. This specifically includes any limitation imposed by any state statute, regulation, or case law including any Workers' Compensation Act provision that applies a limitation to the amount recoverable in contribution such as Kotecki v. Cyclops Welding.

B. Workers' Compensation and Employers' Liability Coverage

The insurer shall agree to waive all rights of subrogation against the member, its officials, employees, agents and volunteers for losses arising from work performed by Contractor for the municipality.

1. NCCI Alternate Employer Endorsement (WC 000301) in place to insure that workers' compensation coverage applies under contractor's coverage rather than member's if the member is borrowing, leasing or in day to day control of contractor's employee.

Required if box is checked .

C. Professional Liability (Required if box is checked)

1. Professional liability insurance with limits not less than \$1,000,00 each claim with respect to negligent acts, errors and omissions in connection with professional services to be provided under the contract, with a deductible not-to-exceed \$50,000 without prior written approval.
2. If the policy is written on a claims-made form, the retroactive date must be equal to or preceding the effective date of the contract. In the event the policy is cancelled, non-renewed or switched to an occurrence form, the Contractor shall be required to purchase supplemental extending reporting period coverage for a period of not less than three (3) years.
3. Provide a certified copy of actual policy for review.
4. Recommended Required Coverage (architect, engineer, surveyor, consultant): Professional liability insurance that provides indemnification and defense for injury or damage arising out of acts, errors, or omissions in providing the following professional services, but not limited to the following:
 - a. Preparing, approving or failure to prepare or approve maps, drawings, opinions, report, surveys, change orders, designs or specifications;
 - b. Providing direction, instruction, supervision, inspection, engineering services or failing to provide them, if that is the primary cause of injury or damage.

D. All Coverages

Each insurance policy required shall have the member expressly endorsed onto the policy as a Cancellation Notice Recipient. Should any of the policies be cancelled before the expiration date thereof, notice will be delivered in accordance with the policy provisions.

ACCEPTABILITY OF INSURERS

Insurance is to be placed with insurers with a Best's rating of no less than A-, VII and licensed to do business in the State of Illinois.

VERIFICATION OF COVERAGE

Contractor shall furnish the member with certificates of insurance naming the member, its officials, employees, agents and volunteers as additional insureds (Exhibit D), and with original endorsements affecting coverage required by this clause. The certificates and endorsements for each insurance policy are to be signed by a person authorized by that insurer to bind coverage on its behalf. The certificates and endorsements are to be received and approved by the member before any work commences. The following additional insured endorsements may be utilized: ISO Additional Insured Endorsements CG 2010 (Exhibit A) or CG 2026 (Exhibit B), and CG 2037 (Exhibit C) – Completed Operations, where required. The member reserves the right to request full certified copies of the insurance policies and endorsements.

SUBCONTRACTORS

Contractor shall include all subcontractors as insureds under its policies or shall furnish separate certificates and endorsements for each subcontractor. All coverages for subcontractors shall be subject to all of the requirements stated herein.

ASSUMPTION OF LIABILITY

The contractor assumes liability for all injury to or death of any person or persons including employees of the contractor, any sub-contractor, any supplier or any other person and assumes liability for all damage to property sustained by any person or persons occasioned by or in any way arising out of any work performed pursuant to this agreement.

II. INDEMNITY/HOLD HARMLESS PROVISION

To the fullest extent permitted by law, the Contractor hereby agrees to defend, indemnify and hold harmless the member, its officials, employees and agents against all injuries, deaths, loss, damages, claims, patent claims, suits, liabilities, judgments, cost and expenses, which may in anywise accrue against the member, its officials, agents and employees, arising in whole or in part or in consequence of the performance of this work by the Contractor, its employees, or subcontractors, or which may in anywise result therefore, except that arising out of the sole legal cause of the member, its employees or agents, the Contractor shall, at its own expense, appear, defend and pay all charges of attorneys and all costs and other expenses arising therefore or incurred in connections therewith, and, if any judgment shall be rendered against the member, its officials, employees and agents, in any such action, the Contractor shall, at its own expense, satisfy and discharge the same.

Contractor expressly understands and agrees that any performance bond or insurance policies required by this contract, or otherwise provided by the Contractor, shall in no way limit the responsibility to indemnify, keep and save harmless and defend the member, its

officials, employees and agents as herein provided.

The Contractor further agrees that to the extent that money is due the Contractor by virtue of this contract as shall be considered necessary in the judgment of the member, may be retained by the member to protect itself against said loss until such claims, suits, or judgments shall have been settled or discharged and/or evidence to that effect shall have been furnished to the satisfaction of the member.

III. SAFETY/LOSS PREVENTION

Safety/Loss Prevention Program Requirements

- Successful bidder will provide written confirmation that a safety/loss prevention program was in place at least 90 days prior to submitting the bid proposal.
- Evidence of completed employee safety training can be provided.

Regulatory Requirements

- Successful bidder must comply with all applicable laws, regulations, and rules promulgated by any Federal, State, County, Municipal and/or other governmental unit or regulatory body now in effect or which may be in effect during the performance of the work. Included within the scope of the laws, regulations, and rules referred to in this paragraph but in no way to operate as a limitation, are Occupational Safety & Health Act (OSHA), Illinois Department of Labor (IDOL), Department of Transportation, all forms of traffic regulations, public utility, Intrastate and Interstate Commerce Commission regulations, Workers' Compensation Laws, Prevailing Wage Laws, the Social Security Act of the Federal Government and any of its titles, the Illinois Department of Human Rights, Human Rights Commission, or EEOC statutory provisions and rules and regulations.
- Evidence of specific regulatory compliance will be provided by bidder, if required by owner.

EXHIBIT A

POLICY NUMBER:

COMMERCIAL GENERAL LIABILITY
CG 20 10 07 04

THIS ENDORSEMENT CHANGES THE POLICY. PLEASE READ IT CAREFULLY.

**ADDITIONAL INSURED – OWNERS, LESSEES OR
CONTRACTORS – SCHEDULED PERSON OR
ORGANIZATION**

This endorsement modifies Insurance provided under the following:

COMMERCIAL GENERAL LIABILITY COVERAGE PART

SCHEDULE

Name Of Additional Insured Person(s) Or Organization(s):	Location(s) Of Covered Operations
<p style="font-size: 48px; opacity: 0.5; transform: rotate(-45deg);">SAMPLE</p>	
<p>Information required to complete this Schedule, if not shown above, will be shown in the Declarations.</p>	

A. Section II – Who Is An Insured is amended to include as an additional insured the person(s) or organization(s) shown in the schedule, but only with respect to liability for "bodily injury," "property damage" or "personal and advertising injury" caused, in whole or in part, by:

1. Your acts or omissions; or
2. The acts or omissions of those acting on your behalf;

in the performance of your ongoing operations for the additional insured(s) at the location(s) designated above.

B. With respect to the insurance afforded to these additional insureds, the following additional exclusions apply:

This Insurance does not apply to "bodily injury" or "property damage" occurring after:

1. All work, including materials, parts or equipment furnished in connection with such work, on the project (other than service, maintenance or repairs) to be performed by or on behalf of the additional insured(s) at the location of the covered operations has been completed; or
2. That portion of "your work" out of which the injury or damage arises has been put to its intended use by any person or organization other than another contractor or subcontractor engaged in performing operations for a principal as a part of the same project.

EXHIBIT B

POLICY NUMBER:

**COMMERCIAL GENERAL LIABILITY
CG 20 26 07 04**

THIS ENDORSEMENT CHANGES THE POLICY. PLEASE READ IT CAREFULLY.

**ADDITIONAL INSURED – DESIGNATED
PERSON OR ORGANIZATION**

This endorsement modifies insurance provided under the following:

COMMERCIAL GENERAL LIABILITY COVERAGE PART

SCHEDULE

Name Of Additional Insured Person(s) Or Organization(s)
<p>SAMPLE</p>
<p>Information required to complete this Schedule, if not shown above, will be shown in the Declarations.</p>

Section II – Who is An Insured is amended to include as an additional insured the person(s) or organization(s) shown in the Schedule, but only with respect to liability for "bodily injury", "property damage" or "personal and advertising injury" caused, in whole or in part, by your acts or omissions or the acts or omissions of those acting on your behalf:

- A.** In the performance of your ongoing operations; or
- B.** In connection with your premises owned by or rented to you.

**EXHIBIT
C**

POLICY NUMBER:

**COMMERCIAL GENERAL LIABILITY
CG 20 37 07 04**

THIS ENDORSEMENT CHANGES THE POLICY. PLEASE READ IT CAREFULLY.

**ADDITIONAL INSURED – OWNERS, LESSEES OR
CONTRACTORS – COMPLETED OPERATIONS**

This endorsement modifies Insurance provided under the following:

COMMERCIAL GENERAL LIABILITY COVERAGE PART

SCHEDULE

Name Of Additional Insured Person(s) Or Organization(s):	Location And Description Of Completed Opera- tions
SAMPLE	
Information required to complete this Schedule, if not shown above, will be shown in the Declarations.	

Section II – Who Is An Insured is amended to include as an additional insured the person(s) or organization(s) shown in the Schedule, but only with respect to liability for "bodily injury" or "property damage" caused, in whole or in part, by "your work" at the location designated and described in the schedule of this endorsement performed for that additional insured and included in the "products-completed operations hazard".



Route	Marked Route	Section Number
	South Michigan Ave	
Project Number	County	Contract Number
	DuPage	

This plan has been prepared to comply with the provisions of the National Pollutant Discharge Elimination System (NPDES) Permit No. ILR10 (Permit ILR10), issued by the Illinois Environmental Protection Agency (IEPA) for storm water discharges from construction site activities.

I certify under penalty of law that this document and all attachments were prepared under my direction or supervision in accordance with a system designed to assure that qualified personnel properly gathered and evaluated the information submitted. Based on my inquiry of the person or persons who manage the system, or those persons directly responsible for gathering the information, the information submitted is, to the best of my knowledge and belief, true, accurate and complete. I am aware that there are significant penalties for submitting false information, including the possibility of fine and imprisonment for knowing violations.

Signature	Date

Print Name	Title	Agency
Rich Salerno	Interim Director of Public Works	Village of Villa Park

Note: Guidance on preparing each section of BDE 2342 can be found in Chapter 41 of the IDOT Bureau of Design and Environment (BDE) Manual. Chapter 41 and this form also reference the IDOT Drainage Manual which should be readily available.

I. Site Description:

A. Provide a description of the project location; include latitude and longitude, section, town, and range:
 S Michigan Ave from W Central Blvd to W Kenilworth Ave. 41°53'5.62"N, 87°59'7.75"W SEC 9, T39N, R11E

B. Provide a description of the construction activity which is the subject of this plan. Include the number of construction stages, drainage improvements, in-stream work, installation, maintenance, removal of erosion measures, and permanent stabilization:
 Roadway reconstruction and storm sewer installation.

C. Provide the estimated duration of this project:
 4 months

D. The total area of the construction site is estimated to be 2.9 acres.
 The total area of the site estimated to be disturbed by excavation, grading or other activities is 1.5 acres.

E. The following are weighted averages of the runoff coefficient for this project before and after construction activities are completed; see Section 4-102 of the IDOT Drainage Manual:
 0.87 (existing and proposed)

F. List all soils found within project boundaries; include map unit name, slope information, and erosivity:
 805B Orthents, clayey, undulating; moderate erosivity
 854B Markham-Ashkum-Beecher complex, 1 to 6 percent slopes; moderate erosivity

G. If wetlands were delineated for this project, provide an extent of wetland acreage at the site; see Phase I report:
 No wetlands are located within the project limits.

H. Provide a description of potentially erosive areas associated with this project:

Excavations and parkways.

I. The following is a description of soil disturbing activities by stages, their locations, and their erosive factors (e.g., steepness of slopes, length of slopes, etc.):

After removing the existing pavement and excavating for water main construction, the exposed soil will be susceptible to erosion for storm events.

J. See the erosion control plans and/or drainage plans for this contract for information regarding drainage patterns, approximate slopes anticipated before and after major grading activities, locations where vehicles enter or exit the site and controls to prevent offsite sediment tracking (to be added after contractor identifies locations), areas of soil disturbance, the location of major structural and non-structural controls identified in the plan, the location of areas where stabilization practices are expected to occur, surface waters (including wetlands) , and locations where storm water is discharged to surface water including wetlands.

K. Identify who owns the drainage system (municipality or agency) this project will drain into:

Village of Villa Park

L. The following is a list of General NPDES ILR40 permittees within whose reporting jurisdiction this project is located:

Village of Villa Park

M. The following is a list of receiving water(s) and the ultimate receiving water(s) for this site. In addition, include receiving waters that are listed as Biologically Significant Streams by the Illinois Department of Natural Resources (IDNR). The location of the receiving waters can be found on the erosion and sediment control plans:

The project site directly discharges to existing municipal storm sewers, which ultimately discharge to Salt Creek.

N. Describe areas of the site that are to be protected or remain undisturbed. These areas may include steep slopes (i.e., 1:3 or steeper), highly erodible soils, streams, stream buffers, specimen trees, natural vegetation, nature preserves, etc. Include any commitments or requirements to protect adjacent wetlands.

For any storm water discharges from construction activities within 50-feet of Waters of the U.S. (except for activities for water-dependent structures authorized by a Section 404 permit, describe: a) How a 50-foot undisturbed natural buffer will be provided between the construction activity and the Waters of the U.S. or b) How additional erosion and sediment controls will be provided within that area.

None

O. Per the Phase I document, the following sensitive environmental resources are associated with this project and may have the potential to be impacted by the proposed development. Further guidance on these resources is available in Section 41-4 of the BDE Manual.

None

303(d) Listed receiving waters for suspended solids, turbidity, or siltation.
The name(s) of the listed water body, and identification of all pollutants causing impairment:

Provide a description of how erosion and sediment control practices will prevent a discharge of sediment resulting from a storm event equal to or greater than a twenty-five (25) year, twenty-four (24) hour rainfall event:

Provide a description of the location(s) of direct discharge from the project site to the 303(d) water body:

Provide a description of the location(s) of any dewatering discharges to the MS4 and/or water body:

Applicable Federal, Tribal, State, or Local Programs

Floodplain

Historic Preservation

Receiving waters with Total Maximum Daily Load (TMDL) for sediment, total suspended solids, turbidity or siltation

TMDL (fill out this section if checked above)

The name(s) of the listed water body:

Provide a description of the erosion and sediment control strategy that will be incorporated into the site design that is consistent with the assumptions and requirements of the TMDL:

If a specific numeric waste load allocation has been established that would apply to the project's discharges, provide a description of the necessary steps to meet that allocation:

Threatened and Endangered Species/Illinois Natural Areas (INAI)/Nature Preserves

Other

Wetland

P. The following pollutants of concern will be associated with this construction project:

- | | |
|--|---|
| <input checked="" type="checkbox"/> Antifreeze / Coolants | <input checked="" type="checkbox"/> Solid Waste Debris |
| <input checked="" type="checkbox"/> Concrete | <input checked="" type="checkbox"/> Solvents |
| <input checked="" type="checkbox"/> Concrete Curing Compounds | <input checked="" type="checkbox"/> Waste water from cleaning construction equipments |
| <input checked="" type="checkbox"/> Concrete Truck Waste | <input type="checkbox"/> Other (Specify) _____ |
| <input checked="" type="checkbox"/> Fertilizers / Pesticides | <input type="checkbox"/> Other (Specify) _____ |
| <input type="checkbox"/> Paints | <input type="checkbox"/> Other (Specify) _____ |
| <input checked="" type="checkbox"/> Petroleum (gas, diesel, oil, kerosene, hydraulic oil / fluids) | <input type="checkbox"/> Other (Specify) _____ |
| <input checked="" type="checkbox"/> Soil Sediment | <input type="checkbox"/> Other (Specify) _____ |

II. Controls:

This section of the plan addresses the controls that will be implemented for each of the major construction activities described in Section I.C above and for all use areas, borrow sites, and waste sites. For each measure discussed, the Contractor will be responsible for its implementation as indicated. The Contractor shall provide to the Resident Engineer a plan for the implementation of the measures indicated. The Contractor, and subcontractors, will notify the Resident Engineer of any proposed changes, maintenance, or modifications to keep construction activities compliant with the Permit ILR10. Each such Contractor has signed the required certification on forms which are attached to, and are a part of, this plan:

A. Erosion and Sediment Controls: At a minimum, controls must be coordinated, installed and maintained to:

1. Minimize the amount of soil exposed during construction activity;
2. Minimize the disturbance of steep slopes;
3. Maintain natural buffers around surface waters, direct storm water to vegetated areas to increase sediment removal and maximize storm water infiltration, unless infeasible;
4. Minimize soil compaction and, unless infeasible, preserve topsoil.

B. Stabilization Practices: Provided below is a description of interim and permanent stabilization practices, including site- specific scheduling of the implementation of the practices. Site plans will ensure that existing vegetation is preserved where attainable and disturbed portions of the site will be stabilized. Stabilization practices may include but are not limited to: temporary seeding, permanent seeding, mulching, geotextiles, sodding, vegetative buffer strips, protection of trees, preservation of mature vegetation, and other appropriate measures. Except as provided below in II.B.1 and II.B.2, stabilization measures shall be initiated immediately where construction activities have temporarily or permanently ceased, but in no case more than one (1) day after the construction activity in that portion of the site has temporarily or permanently ceases on all disturbed portions of the site where construction will not occur for a period of fourteen (14) or more calendar days.

- 1. Where the initiation of stabilization measures is precluded by snow cover, stabilization measures shall be initiated as soon as practicable.
- 2. On areas where construction activity has temporarily ceased and will resume after fourteen (14) days, a temporary stabilization method can be used.

The following stabilization practices will be used for this project:

- | | |
|--|--|
| <input type="checkbox"/> Erosion Control Blanket / Mulching | <input type="checkbox"/> Temporary Turf (Seeding, Class 7) |
| <input type="checkbox"/> Geotextiles | <input type="checkbox"/> Temporary Mulching |
| <input type="checkbox"/> Permanent Seeding | <input type="checkbox"/> Vegetated Buffer Strips |
| <input checked="" type="checkbox"/> Preservation of Mature Seeding | <input type="checkbox"/> Other (Specify) _____ |
| <input checked="" type="checkbox"/> Protection of Trees | <input type="checkbox"/> Other (Specify) _____ |
| <input checked="" type="checkbox"/> Sodding | <input type="checkbox"/> Other (Specify) _____ |
| <input type="checkbox"/> Temporary Erosion Control Seeding | <input type="checkbox"/> Other (Specify) _____ |

Describe how the stabilization practices listed above will be utilized during construction:

Areas outside the pavement will be permanently stabilized with sod after construction of roadway items and sidewalk is complete.

Describe how the stabilization practices listed above will be utilized after construction activities have been completed:

The contractor will provide supplemental watering to permanent sod locations as needed. Once sod establishes into stabilized vegetation, erosion control barriers and inlet filters will be removed.

C. Structural Practices: Provided below is a description of structural practices that will be implemented, to the degree attainable, to divert flows from exposed soils, store flows or otherwise limit runoff and the discharge of pollutants from exposed areas of the site. Such practices may include but are not limited to: perimeter erosion barrier, earth dikes, drainage swales, sediment traps, ditch checks, subsurface drains, pipe slope drains, level spreaders, storm drain inlet protection, rock outlet protection, reinforced soil retaining systems, gabions, and temporary or permanent sediment basins. The installation of these devices may be subject to Section 404 of the Clean Water Act.

- | | |
|--|--|
| <input type="checkbox"/> Aggregate Ditch | <input type="checkbox"/> Stabilized Construction Exits |
| <input type="checkbox"/> Concrete Revetment Mats | <input type="checkbox"/> Stabilized Trench Flow |
| <input type="checkbox"/> Dust Suppression | <input type="checkbox"/> Slope Mattress |
| <input type="checkbox"/> Dewatering Filtering | <input type="checkbox"/> Slope Walls |
| <input type="checkbox"/> Gabions | <input type="checkbox"/> Temporary Ditch Check |
| <input type="checkbox"/> In-Stream or Wetland Work | <input type="checkbox"/> Temporary Pipe Slope Drain |
| <input type="checkbox"/> Level Spreaders | <input type="checkbox"/> Temporary Sediment Basin |
| <input type="checkbox"/> Paved Ditch | <input type="checkbox"/> Temporary Stream Crossing |
| <input type="checkbox"/> Permanent Check Dams | <input type="checkbox"/> Turf Reinforcement Mats |
| <input checked="" type="checkbox"/> Perimeter Erosion Barrier | <input type="checkbox"/> Other (Specify) _____ |
| <input type="checkbox"/> Permanent Sediment Basin | <input type="checkbox"/> Other (Specify) _____ |
| <input type="checkbox"/> Retaining Walls | <input type="checkbox"/> Other (Specify) _____ |
| <input type="checkbox"/> Riprap | <input type="checkbox"/> Other (Specify) _____ |
| <input type="checkbox"/> Rock Outlet Protection | <input type="checkbox"/> Other (Specify) _____ |
| <input type="checkbox"/> Sediment Trap | <input type="checkbox"/> Other (Specify) _____ |
| <input checked="" type="checkbox"/> Storm Drain Inlet Protection | <input type="checkbox"/> Other (Specify) _____ |

Describe how the structural practices listed above will be utilized during construction:

Perimeter erosion barrier will be placed along areas that slope away from the project. Parkway and roadway structures with open grates will be protected with inlet filters.

Describe how the structural practices listed above will be utilized after construction activities have been completed:

All structural practices listed above will remain in place until the permanent sod has established as stabilized vegetation.

D. Treatment Chemicals

Will polymer flocculants or treatment chemicals be utilized on this project: Yes No

If yes above, identify where and how polymer flocculants or treatment chemicals will be utilized on this project.

E. Permanent (i.e., Post-Construction) Storm Water Management Controls: Provided below is a description of measures that will be installed during the construction process to control volume and pollutants in storm water discharges that will occur after construction operations have been completed. The installation of these devices may be subject to Section 404 of the Clean Water Act.

1. Such practices may include but are not limited to: storm water detention structures (including wet ponds), storm water retention structures, flow attenuation by use of open vegetated swales and natural depressions, infiltration of runoff on site, and sequential systems (which combine several practices).

The practices selected for implementation were determined based on the technical guidance in Chapter 41 (Construction Site Storm Water Pollution Control) of the IDOT BDE Manual. If practices other than those discussed in Chapter 41 are selected for implementation or if practices are applied to situations different from those covered in Chapter 41, the technical basis for such decisions will be explained below.

2. Velocity dissipation devices will be placed at discharge locations and along the length of any outfall channel as necessary to provide a non-erosive velocity flow from the structure to a water course so that the natural physical and biological characteristics and functions are maintained and protected (e.g., maintenance of hydrologic conditions such as the hydroperiod and hydrodynamics present prior to the initiation of construction activities).

Description of permanent storm water management controls:

Runoff will be directed to existing and proposed storm sewer structures which will be protected with inlet filters. There are no outfall structures requiring velocity dissipation along this project.

F. Approved State or Local Laws: The management practices, controls and provisions contained in this plan will be in accordance with IDOT specifications, which are at least as protective as the requirements contained in the IEPA's Illinois Urban Manual. Procedures and requirements specified in applicable sediment and erosion site plans or storm water management plans approved by local officials shall be described or incorporated by reference in the space provided below. Requirements specified in sediment and erosion site plans, site permits, storm water management site plans or site permits approved by local officials that are applicable to protecting surface water resources are, upon submittal of an NOI, to be authorized to discharge under the Permit ILR10 incorporated by reference and are enforceable under this permit even if they are not specifically included in the plan.

Description of procedures and requirements specified in applicable sediment and erosion site plans or storm water management plans approved by local officials:

All management practices, controls, and other provisions provided in this plan are in accordance with IDOT Standard Specifications for Road and Bridge Construction.

G. Contractor Required Submittals: Prior to conducting any professional services at the site covered by this plan, the Contractor and each subcontractor responsible for compliance with the permit shall submit to the Resident Engineer a Contractor Certification Statement, BDE 2342A.

1. The Contractor shall provide a construction schedule containing an adequate level of detail to show major activities with implementation of pollution prevention BMPs, including the following items:

- Approximate duration of the project, including each stage of the project
- Rainy season, dry season, and winter shutdown dates
- Temporary stabilization measures to be employed by contract phases
- Mobilization time-frame

- Mass clearing and grubbing/roadside clearing dates
 - Deployment of Erosion Control Practices
 - Deployment of Sediment Control Practices (including stabilized cons
- Deployment of Construction Site Management Practices (including concrete washout facilities, chemical storage, refueling locations, etc.)
 - Paving, saw-cutting, and any other pavement related operations
 - Major planned stockpiling operation
 - Time frame for other significant long-term operations or activities that may plan non-storm water discharges as dewatering, grinding, etc
 - Permanent stabilization activities for each area of the project
2. During the pre-construction meeting, the Contractor and each subcontractor shall provide, as an attachment to their signed Contractor Certification Statement, a discussion of how they will comply with the requirements of the permit in regard to the following items and provide a graphical representation showing location and type of BMPs to be used when applicable:
- Temporary Ditch Checks - Identify what type and the source of Temporary Ditch Checks that will be installed as part of the project. The installation details will then be included with the SWPPP.
 - Vehicle Entrances and Exits - Identify type and location of stabilized construction entrances and exits to be used and how they will be maintained.
 - Material Delivery, Storage and Use - Discuss where and how materials including chemicals, concrete curing compounds, petroleum products, etc. will be stored for this project.
 - Stockpile Management - Identify the location of both on-site and off-site stockpiles. Discuss what BMPs will be used to prevent pollution of storm water from stockpiles.
 - Waste Disposal - Discuss methods of waste disposal that will be used for this project.
 - Spill Prevention and Control - Discuss steps that will be taken in the event of a material spill (chemicals, concrete curing compounds, petroleum, etc.)
 - Concrete Residuals and Washout Wastes - Discuss the location and type of concrete washout facilities to be used on this project and how they will be signed and maintained.
 - Litter Management - Discuss how litter will be maintained for this project (education of employees, number of dumpsters, frequency of dumpster pick-up, etc.).
 - Vehicle and Equipment Fueling - Identify equipment fueling locations for this project and what BMPs will be used to ensure containment and spill prevention.
 - Vehicle and Equipment Cleaning and Maintenance - Identify where equipment cleaning and maintenance locations for this project and what BMPs will be used to ensure containment and spill prevention.
 - Dewatering Activities - Identify the controls which will be used during dewatering operations to ensure sediments will not leave the construction site.
 - Polymer Flocculants and Treatment Chemicals - Identify the use and dosage of treatment chemicals and provide the Resident Engineer with Material Safety Data Sheets. Describe procedures on how the chemicals will be used and identify who will be responsible for the use and application of these chemicals. The selected individual must be trained on the established procedures.
 - Additional measures indicated in the plan.

III. Maintenance:

When requested by the Contractor, the Resident Engineer will provide general maintenance guides (e.g., IDOT Erosion and Sediment Control Field Guide) to the Contractor for the practices associated with this project. Describe how all items will be checked for structural integrity, sediment accumulation and functionality. Any damage or undermining shall be repaired immediately. Provide specifics on how repairs will be made. The following additional procedures will be used to maintain, in good and effective operating conditions, the vegetation, erosion and sediment control measures and other protective measures identified in this plan. It will be the Contractor's responsibility to attain maintenance guidelines for any manufactured BMPs which are to be installed and maintained per manufacture's specifications.

All erosion and sediment control measures should be checked weekly and after each significant rainfall, 0.5 inch or greater in a 24 hour period, or equivalent snowfall. Additionally, during winter months, all measures should be checked after each additional snowmelt. All erosion and sediment control measures should be included in the list of items to be inspected. All maintenance of erosion control systems is the responsibility of the contractor, and is a requirement of the contract.

IV. Inspections:

Qualified personnel shall inspect disturbed areas of the construction site including Borrow, Waste, and Use Areas, which have not yet been finally stabilized, structural control measures, and locations where vehicles and equipment enter and exit the site using IDOT Storm Water Pollution Prevention Plan Erosion Control Inspection Report, BC 2259. Such inspections shall be conducted at least once every seven (7) calendar days and within twenty-four (24) hours of the end of a storm or by the end of the following business or work day that is 0.5 inch or greater or equivalent snowfall.

Inspections may be reduced to once per month when construction activities have ceased due to frozen conditions. Weekly inspections will recommence when construction activities are conducted, or if there is 0.5" or greater rain event, or a discharge due to snowmelt occurs.

If any violation of the provisions of this plan is identified during the conduct of the construction work covered by this plan, the Resident Engineer shall notify the appropriate IEPA Field Operations Section office by email at: epa.swnoncomp@illinois.gov, telephone or fax within twenty-four (24) hours of the incident. The Resident Engineer shall then complete and submit an "Incidence of Non-Compliance" (ION) report for the identified violation within five (5) days of the incident. The Resident Engineer shall use forms provided by IEPA and shall include specific information on the cause of noncompliance, actions which were taken to prevent any further causes of noncompliance, and a statement detailing any environmental impact which may have resulted from the noncompliance. All reports of non-compliance shall be signed by a responsible authority in accordance with Part VI. G of the Permit ILR10.

The Incidence of Non-Compliance shall be mailed to the following address:

Illinois Environmental Protection Agency
Division of Water Pollution Control
Attn: Compliance Assurance Section
1021 North Grand East
Post Office Box 19276
Springfield, Illinois 62794-9276

V. Failure to Comply:

Failure to comply with any provisions of this Storm Water Pollution Prevention Plan will result in the implementation of a National Pollutant Discharge Elimination System/Erosion and Sediment Control Deficiency Deduction against the Contractor and/or penalties under the Permit ILR10 which could be passed on to the Contractor.



Illinois Environmental Protection Agency

1021 North Grand Avenue East • P.O. Box 19276 • Springfield • Illinois • 62794-9276 • (217) 782-3397

Division of Water Pollution Control Notice of Intent (NOI) for General Permit to Discharge Storm Water Associated with Construction Site Activities

This fillable form may be completed online, a copy saved locally, printed and signed before it is submitted to the Permit Section at the above address.

For Office Use Only

OWNER INFORMATION

Permit No. ILR10 _____

Company/Owner Name: Village of Villa Park

Mailing Address: 20 South Ardmore Phone: 630-834-5205

City: Villa Park State: IL Zip: 60181 Fax: 630-834-8509

Contact Person: Rich Salerno E-mail: richs@invillapark.com

Owner Type (select one) City

MS4 Community: Yes No

CONTRACTOR INFORMATION

Contractor Name: _____

Mailing Address: _____ Phone: _____

City: _____ State: _____ Zip: _____ Fax: _____

CONSTRUCTION SITE INFORMATION

Select One: New Change of information for: ILR10 _____

Project Name: S Michigan Avenue Reconstruction County: DuPage

Street Address: S Michigan - Central to Kenilworth City: Villa Park IL Zip: 60181

Latitude: 41 53 5.62 Longitude: 87 59 7.75 9 39N 11E
(Deg) (Min) (Sec) (Deg) (Min) (Sec) Section Township Range

Approximate Construction Start Date May 25, 2020 Approximate Construction End Date Jul 31, 2020

Total size of construction site in acres: 1.5

If less than 1 acre, is the site part of a larger common plan of development?

Yes No

Fee Schedule for Construction Sites:
Less than 5 acres - \$250
5 or more acres - \$750

STORM WATER POLLUTION PREVENTION PLAN (SWPPP)

Has the SWPPP been submitted to the Agency? Yes No

(Submit SWPPP electronically to: epa.constilr10swppp@illinois.gov)

Location of SWPPP for viewing: Address: 20 South Ardmore City: Villa Park

SWPPP contact information: Inspector qualifications: _____

Contact Name: Rich Salerno P.E. _____

Phone: 630-834-8505 Fax: 630-834-8509 E-mail: richs@invillapark.com

Project inspector, if different from above Inspector qualifications: _____

Inspector's Name: _____

Phone: _____ Fax: _____ E-mail: _____

This Agency is authorized to require this information under Section 4 and Title X of the Environmental Protection Act (415 ILCS 5/4, 5/39). Failure to disclose this information may result in: a civil penalty of not to exceed \$50,000 for the violation and an additional civil penalty of not to exceed \$10,000 for each day during which the violation continues (415 ILCS 5/42) and may also prevent this form from being processed and could result in your application being denied. This form has been approved by the Forms Management Center.

TYPE OF CONSTRUCTION (select one)

Construction Type Transportation

SIC Code: _____

Type a detailed description of the project:

The project includes roadway reconstruction; storm sewer installation; sanitary sewer repairs; water main service adjustment; sidewalk repair; parkway restoration; and other incidental and miscellaneous items of work .

The project is located on South Michigan Avenue from West Central Boulevard to West Kenilworth Avenue in the Village of Villa Park, DuPage County, Illinois.

HISTORIC PRESERVATION AND ENDANGERED SPECIES COMPLIANCE

Has the project been submitted to the following state agencies to satisfy applicable requirements for compliance with Illinois law on:

Historic Preservation Agency Yes No

Endangered Species Yes No

RECEIVING WATER INFORMATION

Does your storm water discharge directly to: Waters of the State or Storm Sewer

Owner of storm sewer system: Village of Villa Park

Name of closest receiving water body to which you discharge: Salt Creek

Mail completed form to: Illinois Environmental Protection Agency
Division of Water Pollution Control
Attn: Permit Section
Post Office Box 19276
Springfield, Illinois 62794-9276
or call (217) 782-0610
FAX: (217) 782-9891

Or submit electronically to: epa.constilr10swppp@illinois.gov

I certify under penalty of law that this document and all attachments were prepared under my direction and supervision in accordance with a system designed to assure that qualified personnel properly gather and evaluate the information submitted. Based on my inquiry of the person or persons who manage this system, or those persons directly responsible for gathering the information, the information submitted is, to the best of my knowledge and belief, true, accurate, and complete. I am aware that there are significant penalties for submitting false information, including the possibility of fine and imprisonment. In addition, I certify that the provisions of the permit, including the development and implementation of a storm water pollution prevention plan and a monitoring program plan, will be complied with.

Any person who knowingly makes a false, fictitious, or fraudulent material statement, orally or in writing, to the Illinois EPA commits a Class 4 felony. A second or subsequent offense after conviction is a Class 3 felony. (415 ILCS 5/44(h))

Owner Signature:

Date:

Printed Name:

Title:

INSTRUCTIONS FOR COMPLETION OF CONSTRUCTION ACTIVITY NOTICE OF INTENT (NOI) FORM

Submit original, electronic or facsimile copies. Facsimile and/or electronic copies should be followed-up with submission of an original signature copy as soon as possible. Please write "copy" under the "For Office Use Only" box in the upper right hand corner of the first page.

This fillable form may be completed online, a copy saved locally, printed and signed before it is submitted to the Permit Section at:

Illinois Environmental Protection Agency
 Division of Water Pollution Control
 Permit Section
 Post Office Box 19276
 Springfield, Illinois 62794-9276
 or call (217) 782-0610

FAX: (217) 782-9891

Or submit electronically to: epa.constilr10swppp@illinois.gov

Reports must be typed or printed legibly and signed.

Any facility that is not presently covered by the General NPDES Permit for Storm Water Discharges From Construction Site Activities is considered a new facility.

If this is a change in your facility information, renewal, etc., please fill in your permit number on the appropriate line, changes of information or permit renewal notifications do not require a fee.

NOTE: FACILITY LOCATION IS NOT NECESSARILY THE FACILITY MAILING ADDRESS, BUT SHOULD DESCRIBE WHERE THE FACILITY IS LOCATED.

Use the formats given in the following examples for correct form completion.

	Example	Format
Section	12	1 or 2 numerical digits
Township	12N	1 or 2 numerical digits followed by "N" or "S"
Range	12W	1 or 2 numerical digits followed by "E" or "W"

For the Name of Closest Receiving Waters, do not use terms such as ditch or channel. For unnamed tributaries, use terms which include at least a named main tributary such as "Unnamed Tributary to Sugar Creek to Sangamon River."

Submission of initial fee and an electronic submission of Storm Water Pollution Prevention Plan (SWPPP) for Initial Permit prior to the Notice of Intent being considered complete for coverage by the ILR10 General Permits. Please make checks payable to: Illinois EPA at the above address.

Construction sites with less than 5 acres of land disturbance - fee is \$250.

Construction sites with 5 or more acres of land disturbance - fee is \$750.

SWPPP should be submitted electronically to: epa.constilr10swppp@illinois.gov. When submitting electronically, use Project Name and City as indicated on NOI form.

