



**VILLAGE OF VILLA PARK**

**CONTRACT DOCUMENTS**

**FOR**

**2019 SEWER REHABILITATION PROGRAM**

**JUNE 2019**

**PREPARED BY**

**rjngroup**

Excellence through Ownership

200 West Front Street  
Wheaton, Illinois 60187  
(630) 682-4700  
[www.RJN.com](http://www.RJN.com)

*This page intentionally left blank.*

2019 SEWER REHABILITATION PROGRAM

VILLAGE OF VILLA PARK

ILLINOIS

JUNE 2019

I hereby state that these Contract Documents were prepared under my direct supervision and that I am a duly Registered Professional Engineer under the laws of the State of Illinois.



*Catherine L. Morley*

(Expiration Date: November 30<sup>th</sup>, 2019)

Professional Design Firm Registration 184.000813-0002 (Expiration Date: April 30<sup>th</sup>, 2021)

***This page intentionally left blank.***

**VILLAGE OF VILLA PARK  
2019 SEWER REHABILITATION PROGRAM**

**TABLE OF CONTENTS**

<u>Title</u>	<u>Pages through</u>
Notice to Bidders and Invitation for Bids .....	00100 - 02
Instructions to Bidders .....	00200 - 18
Bid .....	00400 - 12
Bidder Qualifications .....	00410 - 04
Bid Bond .....	00420 - 02
Contractor's Certification .....	00430 - 02
Bidder Certification in Compliance with Article 33E .....	00440 - 02
Bidder Certification for use of American Steel .....	00445 - 02
Certification Regarding Debarment, Suspension and Other Responsibility Matters .....	00450 - 02
Fair Employment Practices - Affidavit of Compliance .....	00460 - 02
Non-Collusion and Certification Statement .....	00465 - 02
Certification of Non-Segregated Facilities .....	00470 - 02
Disadvantaged Business Enterprise Participation .....	00480 - 14
Goals for Minority Participation .....	00490 - 14
Non Discrimination in Employment .....	00493 - 02
Davis Bacon Wage Act Certification .....	00495 - 08
Notice of Intent to Award .....	00509 - 02
Notice of Award .....	00510 - 02
Contract .....	00520 - 12
Performance Bond .....	00530 - 04
Payment Bond .....	00540 - 04
Notice to Proceed .....	00550 - 02

***This page intentionally left blank.***

Change Order Form .....00560 - 02

Davis Bacon and IDOL Wage Rates .....00699 - 22

Standard General Conditions of the Construction Contract (EJCDC 2013) .....00700 - 72

Supplementary Conditions to the Standard General Conditions .....00800 - 06

Special Provisions .....00900 - 63

Appendix 1: Sewer lining, grouting and point repair location map..... 01

Appendix 2: Point Repair Schedule, TV and Photo Reports, Plans and Profiles..... 25

Appendix 3: Lining & Grouting Schedule and Location Maps ..... 9

Appendix 4: Manhole Rehabilitation Schedule and Location Maps..... 3

Appendix 5: Ordinance 3733 and Insurance Guidelines ..... 11

Appendix 6: IDOT Standard Details..... 8

***This page intentionally left blank.***

**NOTICE TO BIDDERS AND INVITATION FOR BIDS  
FOR THE  
2019 SEWER REHABILITATION PROGRAM**

**VILLAGE OF VILLA PARK  
20 SOUTH ARDMORE AVENUE  
VILLA PARK  
DUPAGE COUNTY, ILLINOIS 60181**

**RECEIPT OF BIDS**

Sealed bids to complete all work required for the 2019 SEWER REHABILITATION PROGRAM will be received by the Village of Villa Park Public Works Department located at 11 West Home Ave., Villa Park, IL 60181 until 11:00 a.m., on July 30, 2019. Thereafter or as soon as thereafter is practicable, all bids received will be publicly opened and the bid prices read aloud. Sealed envelopes or packages containing bids shall be addressed to the Village of Villa Park Department of Public Works, 11 West Home Avenue, Villa Park, IL 60181, and shall be marked:

**“Sealed Bid – Village of Villa Park – 2019 Sewer Rehabilitation Program”**

**2019 Sewer Rehabilitation Program**

The work will consist of the rehabilitation of 30 manholes, 22,000 linear feet of sewer lining with diameter ranging between 8” and 21”, grouting of 100 laterals, installation of 2 T-liners and 1 new service lateral, 4 point repairs, restoration and other related and incidental work as set forth in the Contract Documents.

**CONTRACT REQUIREMENTS**

Any contract awarded under this invitation for bids are expected to be funded in part by a loan from the Illinois Environmental Protection Agency (Illinois EPA). Neither the State of Illinois nor any of its departments, agencies, or employees is or will be a party to this invitation for bids or any resulting contract. The procurement will be subject to regulations contained in the Procedures for Issuing Loans from the Water Pollution Control Loan Program (35 IAC Part 365), the Davis-Bacon Act (40 USC 276a through 276a-5) as defined by the United States Department of Labor, and the Employment of Illinois Workers on Public Works Act (30 ILCS 570), and the “Use of American Iron and Steel” requirements as contained in Section 436 of H.R. 3547, The Consolidated Appropriations Act, 2014. This procurement is also subject to the loan recipient’s policy regarding the increased use of disadvantaged business enterprises. The loan recipient’s policy requires all bidders to undertake specified affirmative efforts at least sixteen (16) days prior to bid opening. The policy is contained in the specifications. Bidders are also required to comply with the President’s Executive Order No. 11246, as amended. The requirements for bidders and contractors under this order are explained in 41 CFR 60-4.

**CONTRACT DOCUMENTS**

The Bidding Documents are on file for inspection at the office of the Village of Villa Park Public Works Department, 11 West Home Avenue, Villa Park, Illinois, 60181. Digital copies of the bid documents are available at [www.questcdn.com](http://www.questcdn.com) for a non-refundable fee of \$30.00. These documents may be downloaded by entering Quest Project Number 6396570 on [www.questcdn.com](http://www.questcdn.com).

A "not-for-bid" version of the bidding documents will also be available on the project page on the Village's website. This version is for informational purposes only, and may not be used for the preparation or submittal of a bid.

**BID SECURITY**

Bid security in the amount of not less than five percent (5%) of the Bid shall accompany each Bid in accordance with the Bidding Documents.

**CONTRACT SECURITY**

The Bidder to whom a Contract is awarded shall be required to furnish both a Performance Bond and a Payment Bond acceptable to the Village for one-hundred percent (100%) of the Contract Price, in accordance with the requirements of the Contract Documents.

**RIGHTS RESERVED**

The Village reserves the right to reject any and all Bids, to waive any informalities or technicalities in bidding, and to accept the Bid which best serves the interests of the Village. The Village shall, in its sole discretion, determine what does or does not contribute an informality or technicality, and, in submitting a Bid, Bidder agrees to be bound by that determination.

**PRE-BID MEETING**

Pre-Bid Meeting will be held at 10:00 am on July 11, 2019 at the Public Works Department, Village of Villa Park, 11 West Home Avenue, Villa Park, IL 60181. This meeting is not mandatory but is highly recommended.

**AWARD OF CONTRACT**

Unless all bids are rejected, the contract award will be made to the lowest responsive responsible bidder. In determining who the lowest responsive responsible bidder is, the Village of Villa Park will consider all factors which it, in its discretion, deems relevant in determining who the lowest responsive responsible bidder is. Bidders who are awarded a contract shall be required to provide a Contract Bond, in the total amount of the contract sum upon execution of the contract.

Dated: This Saturday 15<sup>th</sup> day of June, 2019

**PUBLISHED BY AUTHORITY OF THE VILLAGE OF VILLA PARK, ILLINOIS,  
DU PAGE COUNTY.**

BY: Rich Salerno  
Interim Director of Public Works

**INSTRUCTIONS FOR BIDDERS****ARTICLE 1. Preparation of Bids**

**1.01.** Bidders shall follow all instructions contained herein and included in the Invitation for Bids and bid forms for submission of bids on the contract item for which bids are sought.

**1.02.** Bidders shall submit their bids in the manner required by the Invitation for Bids.

**1.03.** The Bidder must submit its proposal on the supplied Proposal form. Unless otherwise provided, all prices shall be given in figures. Separate prices shall be entered for all pricing items indicated in the bid form. When alternate bids are sought for a particular contract item, the alternates will be identified in the bid form. A bid on every alternate is required unless otherwise specifically provided. When required by the Invitation for Bids, the bidder shall indicate a unit price for each of the separate price items called for in the bid form. The bidder may be required to show the products of the respective quantities and unit prices in a space provided for that purpose, and a gross sum shown in the place indicated in the bid form as the summation of those products. All writing shall be in a permanent, non-erasable form, except the signature of the bidder, which shall be written in permanent, non-erasable ink. Proposals shall be free of erasures or interlineations. Proposals modified by erasures or interlineations will not be considered. Partial bids will not be considered.

**1.04.** Each bid shall be accompanied by a bid bond in the form provided by the Village of Villa Park with the bid form package. The bid bond shall be made and tendered by a surety acceptable to the Village of Villa Park in the amount stated in the Invitation for Bids. The Village of Villa Park will accept a bank cashier's check or a certified check in lieu of a surety bid bond.

**1.05.** Bidders, before submitting their proposal, shall carefully examine the provisions of the contract documents, inspect in detail the site of the proposed work, investigate and become familiar with all the local conditions affecting the contract and the wage rates applicable to the work, become fully informed as to the quality, quantity, cost, sources of supply, and time of delivery of the materials and equipment required and become fully acquainted with the detailed requirements of the construction.

**1.06.** The Davis Bacon rate or the general prevailing rate of wages in DuPage County (whichever is higher) for each craft or type of worker or mechanic needed to execute the contract or perform the work, also the general prevailing rate for legal holiday and overtime work, as ascertained by the Illinois Department of Labor shall be paid.

**ARTICLE 2. Qualifications of Bidders.**

**2.01.** Bidders shall comply with all applicable Federal, State and local laws and requirements, and shall further meet the qualifications prescribed in this and other sections of these specifications.

**2.02.** Bidder, in submitting a Bid, certifies that Bidder is in compliance with all applicable Federal, State and local laws and requirements, and that Bidder further meets the qualifications prescribed in this and other sections of these specifications. OWNER'S determination as to the compliance and qualifications of the Bidder shall be final, and Bidder, in submitting a Bid, agrees to be bound by that determination.

**2.03.** Bidder, in submitting a Bid, certifies that Bidder is in compliance with the following requirements and qualifications. Bidder further certifies that Bidder is able to provide written evidence of Bidder's compliance with the following requirements and qualifications. Bidder shall, upon request by OWNER, submit such written evidence within five (5) calendar days of OWNER'S request, as well as any other written evidence which OWNER may deem necessary for the purpose of evaluating Bidder's qualifications.

**2.03.1.** Bidder shall be qualified to do business in the State of Illinois.

**2.03.2.** Bidder shall possess either a valid Federal Employer Tax Identification Number (FEIN) or a valid Social Security Number (SSN).

**2.03.3.** Bidder shall be able to provide a street address and description of the Bidder's place of business, and the mailing address of the business, if different from the street address.

**2.03.4.** Bidder shall be able to provide the number of years Bidder has been engaged in the contracting business under the present firm name, and the name of the state where incorporated.

**2.03.5.** Bidder shall be able to provide a list of the property and equipment available to the Bidder.

**2.03.6.** Bidder shall be able to provide a financial statement demonstrating that the Bidder has the financial resources to meet all obligations related to the Work.

**2.03.7.** Bidder shall maintain insurance policies with the coverages required by the Contract, and with the minimum limits of coverage required by the Contract. Bidder shall be able to provide current certificate(s) of insurance for the insurance policies held by Bidder, demonstrating that Bidder holds insurance policies with the coverages required by the contract, and with the minimum limits of coverage required by the Contract.

**2.03.8.** Bidder shall have constructed a minimum of three (3) projects of a similar nature in the immediate past five (5) years. Bidder shall be able to provide a list of all projects of a similar nature constructed by Bidder in the immediate past five (5) years, which list shall contain the minimum of three (3) such projects, which list shall provide a description and the location(s) of all such projects, and shall contain the Bidder's performance record and references, as well as the names and current contact information, including addresses and telephone numbers, of persons who acted as owners' representatives for those projects and who have knowledge of those projects,

and whom Bidder agrees OWNER may contact for the purpose of verifying Bidder's performance and references.

**2.03.9.** Bidder shall be able to provide a list of three (3) references (name, address and telephone number) with knowledge of the integrity and business practices of the bidder. Such references may not be persons who have been employed by Bidder as employees.

**2.03.10.** Bidder shall be able to provide a list of projects presently under Contract, the awarded Contract amount of each, the approximate adjusted Contract amount of each (if applicable), and the dollar amount or percent of completion of each.

**2.03.11.** Bidder shall be able to provide a list of Contracts which have resulted in lawsuits, whether against Bidder as a prime contractor, against Bidder as a subcontractor, or against Bidder as a party in any other capacity; or against subcontractors or suppliers performing work for Bidder or under Contract held by Bidder.

**2.03.12.** Bidder shall be able to provide a list of Contracts defaulted.

**2.03.13.** Bidder shall be able to provide a statement indicating whether or not Bidder has ever filed bankruptcy.

**2.03.14.** Bidder shall be able to provide a list of all officers of the firm, which list shall also indicate those officers who, while in the employ of the firm or in the employ of previous firms, were associated with Contracts which resulted in lawsuits, Contracts defaulted, or firms which filed for bankruptcy.

**2.03.15.** Bidder shall maintain personnel guaranteed to be employed in the responsible charge of the Work, which personnel possess sufficient technical experience to ensure the satisfactory completion of the Work. Bidder shall be able to provide the names and technical experience of such personnel, as well as statements as to whether the personnel have or have not performed satisfactorily on other contracts of like nature and magnitude or comparable difficulty at similar rate of progress.

**2.03.16.** Bidder shall be able to provide a list of subcontractors and suppliers anticipated to be employed by Bidder for the purpose of completing the Work, including the firm name, street address and description of place of business; mailing address of business (if different); phone, fax and e-mail contact information of business; name of primary contact; and a list of any projects or contracts for which Bidder currently owes monies to said firm, which list shall include a description of the project or contract, the amount currently due to said firm, the period of time for which those monies have been owed, and the expected date of payment of those monies.

**2.03.17.** Bidder shall participate in active apprenticeship and training programs approved by and registered with the United States Department of Labor Bureau of Apprenticeship and Training for each of the trades of work contemplated under the Contract. Bidder shall be able to provide evidence of

Bidder's participation in such apprenticeship and training programs.

**2.03.18.** Bidder shall only employ subcontractors who meet the requirements prescribed in this section and other sections of these specifications.

**2.03.19.** Bidder shall be able to provide such other information as may assist OWNER in determining whether the Bidder is adequately prepared to fulfill the Contract.

**2.04.** These requirements and qualifications are not intended to discourage bidding, to make it difficult for qualified Bidders to submit Bids, or to discourage beginning contractors. The purpose of these requirements and qualifications is to allow OWNER to obtain sufficient information about Bidder's financial state, available equipment, personnel, and previous work experience so that OWNER may mitigate the hazards involved in awarding contracts to parties who may not be qualified to perform the Work as specified.

### **ARTICLE 3. Certifications**

Each bid shall be accompanied by a Bidder's Certification in the form provided by the Village of Villa Park with the bid form package. The Bidder shall certify the following:

#### **3.01. Illinois Taxes**

The Bidder shall certify that if it is a partnership, that it is, and its general partners are and, if it is a corporation, its shareholders holding more than five percent (5%) of the outstanding shares of the corporation, its officers and directors are, not delinquent in the payment of taxes to the Illinois Department of Revenue in accordance with 65 ILCS 5/11-42.1-1.

#### **3.02. Bid Rigging**

The Bidder shall certify that, if it is a partnership, that it has, and its general partners have and, if it is a corporation, its shareholders holding more than five percent (5%) of the outstanding shares of the corporation, its officers and directors have not been barred from contracting with a unit of state or local government as a result of a violation of Section 33E-3 or 33E-4 of the Criminal Code of 1961.

#### **3.03. Payment of Prevailing Wages**

The Bidder shall certify that it has and will comply with all laws relating to the payment of general prevailing wages in accordance with the Illinois Prevailing Wage Act (820 ILCS 130/0.01 et seq.); This Contract is also subject to the requirements of the Davis Bacon Act (40 U.S.C. 276a through 276a-S). Payment shall be made at the Illinois prevailing wage rate for DuPage County or at the Davis Bacon rate, whichever is the higher.

### **ARTICLE 4. Affidavit of Availability**

Each bid shall be accompanied by an Affidavit of Availability in the form provided by the Village of Villa Park with the bid form package.

**ARTICLE 5. Experience**

The Bidder shall provide the business information, information regarding terminations, litigation, suspension and debarment requested by the Village of Villa Park and at least two (2) references to the Village of Villa Park of work successfully performed, similar in nature to the proposed work, within the past five (5) years. The following shall be provided for each project.

**5.01.** The project owner's name.

**5.02.** The name, address, telephone number and email address of the project owner's contact person.

**5.03.** The services provided and the dollar value of work performed on the project.

**5.04.** The inclusive dates the work was performed.

**ARTICLE 6. Delivery of Bids**

Bids shall be sealed and submitted in the manner specified or allowed by the Invitation for Bids. When sent by mail, the sealed bid shall be addressed to the Village of Villa Park at the address and in care of the Village of Villa Park Clerk. All bids shall be delivered and received by the Village of Villa Park prior to the time and at the place specified in the Invitation for Bids. The date and time of receipt will be recorded. Bids will remain sealed and will be stored in a secure place until the date and time established for bid opening. Bids received after the time specified will be returned to the bidder unopened.

**ARTICLE 7. Change or Withdrawal of Bids**

A bidder may change or withdraw a bid if written or in-person notice of the change or withdrawal is received by the Village of Villa Park Clerk before the time specified for submission of bids. No change or withdrawal is allowed after bid opening except as provided in Section 10 below. Changes must be initialed in ink by the bidder.

**ARTICLE 8. Public Opening of Bids**

Bids will be opened and read publicly at the time and place specified in the Invitation for Bids. The name of each bidder and the price term of each bid will be read aloud and recorded in a tabulation of bids for each contract item advertised. After execution of the contract, the tabulation of bids in the total amount and unit price items, if applicable, of all bidders will be available for public inspection.

**ARTICLE 9. Consideration of Bids**

**09.01.** After the bids are opened, read and recorded, the bids will be reviewed for responsiveness to the Invitation for Bids and conformity with all requirements prescribed in these Instructions. If unit prices are required, the bids will be compared on the basis of the summation of the products of the quantities shown in the bid schedule by the unit bid prices.

**09.02.** The right is reserved by the Village of Villa Park to reject any or all bids, to waive minor informalities or technicalities, to advertise for new bids, or to request confirmation or clarification from any bidder regarding information contained in a bid.

**09.03.** Reasons for rejection of any individual bids include, but are not limited to:

**9.03.1.** More than one bid for the same contract item from a bidder under the same or different names.

**9.03.2.** Evidence of collusion among bidders.

**9.03.3.** Unbalanced bids in which the bid prices for some items are, in the judgment of the Village of Villa Park, out of proportion to the bid prices for other items.

**9.03.4.** If the bid does not contain a unit price for each pay item listed, except in the case of authorized alternate pay items or lump sum pay items.

**9.03.5.** If the bid form is other than that furnished or authorized by the Village of Villa Park, or if the form is altered or any part thereof is detached.

**9.03.6.** If there are omissions, erasures, alterations, unauthorized additions, conditional or alternate bids, or irregularities of any kind that may tend, in the judgment of the Village of Villa Park, to make the bid incomplete, indefinite, or ambiguous as to its meaning.

**9.03.7.** If the bidder adds any provisions reserving the right to accept or reject an award, or to enter into a contract pursuant to an award.

**9.03.8.** If the bid is not accompanied by the proper bid bond or substitute guaranty.

**9.03.9.** If the bid is prepared in any manner other than as indicated in these Instructions or the Invitation for Bids making the bid not responsive.

**ARTICLE 10. Mistakes**

**10.01.** If a bidder claims a mistake in its bid, the bid may be withdrawn in accordance with this section without payment of damages to the Village of Villa Park as provided in the terms of a bid bond or other bid security, provided the bidder claiming the mistake demonstrates to the Village of Villa Park with competent and reliable evidence:

**10.01.1.** that the claimed mistake is related to a material feature of the contract;

**10.01.2.** that the mistake would have serious, material consequences to the bidder such that enforcement of a contract would be unconscionable;

**10.01.3.** that the mistake occurred notwithstanding the exercise of reasonable care by the bidder; and

**10.01.4.** that the bidder has raised the claim of a mistake without delay in order to prevent the Village of Villa Park from altering its position in such a manner that loss to the Village of Villa Park would occur.

**10.02.** The Village of Villa Park reserves the right to correct obvious, apparent errors in bids. A bid may not be withdrawn if a mistake is apparent and the intended correct bid is clearly evident on the face of the bid. Examples of mistakes that may be clearly evident on the face of the bid include, but are not limited to, typographical errors, errors in extending unit prices, transposition errors and arithmetical errors.

**10.03.** Mistakes claimed after execution of the contract will not be corrected.

#### **ARTICLE 11. Award after Bid Evaluation**

**27.01.** Unless all bids are rejected, an award notification will be made to the lowest responsible bidder whose bid is responsive to and conforms with the requirements and criteria of the invitation. Tie bids will be decided by lot. All responsibility, responsiveness, and price factors are considered so as to select the bid most advantageous to the Village of Villa Park. An individual contract item advertised in an Invitation for Bids may state other, additional award and evaluation criteria that will be capable of objective consideration for award.

**27.02.** Responsibility of bidders will be determined based upon the following factors unless some other or additional factors or prequalification procedures are stated in the Invitation for Bids:

**11.02.1.** The bidder shall possess the appropriate financial, material, equipment, facility and personnel resources and expertise necessary to meet all contractual obligations.

**11.02.2.** The bidder shall have a satisfactory record of performance as determined by the Village of Villa Park, including but not limited to, a sound record of integrity and business ethics.

**11.02.3.** The bidder shall be under no legal disability of any kind to contract with the Village of Villa Park.

**11.02.4.** The bidder shall have submitted all information requested by the Invitation for Bids concerning responsibility.

#### **ARTICLE 12. Time for Award**

Unless the Invitation for Bids specifies a different time for bid acceptance, a notification of award will be made in writing dated within one hundred and twenty (120) calendar days after the opening of bids.

**ARTICLE 13. Delay in Award**

Should circumstances be encountered after the bid opening that may delay the award beyond the one hundred and twenty (120) day or other advertised period, the responsive bidders may be requested to extend the bid acceptance period.

**ARTICLE 14. Binding Contract**

**14.01.** Once an award has been made, the bidder is bound to perform according to the terms and conditions of the contract, the Invitation for Bids, and these Instructions.

**14.02.** An approved contract executed by the Village of Villa Park is required before the Village of Villa Park is bound. An award may be canceled at any time by the Village of Villa Park prior to execution in order to protect the public interest and integrity of the bidding process or for any other reason if, in the judgment of the Village of Villa Park, the best interests of the Village of Villa Park will be promoted.

**ARTICLE 15. Requirement of Performance and Payment Bonds**

The successful bidder awarded a contract shall furnish the Village of Villa Park a Performance bond and Payment bond with good and sufficient sureties in the full amount of the contract as the penal sum. (See the Public Construction Bond Act [30 ILCS 550].) The surety shall be acceptable to the Village of Villa Park, shall waive notice of any changes and extensions of time, and shall submit its bond on the form furnished by the Village of Villa Park. Performance security for other contracts shall be as stated in the Invitation and contract.

**ARTICLE 16. Insurance Requirements**

The successful bidder awarded a contract shall furnish and maintain the insurance coverage specified in the contract documents provided by insurance companies acceptable to the Village of Villa Park and authorized to transact business under the laws of the State of Illinois. The insurance companies providing coverage shall be rated in the Best's Key Rating Guide. The Village of Villa Park will accept companies with a rating not lower than B+ provided the financial size category is VII or larger. Companies rated A- or better shall have a financial size category of not less than VI. Coverage limits shall be written at not less than the minimum specified in the contract documents.

**ARTICLE 17. Execution of Contract**

**17.01.** The bid form submitted by the bidders may be in such a form that the signature of the bidder on the form is also the signature of the bidder for purposes of contract execution. In such circumstances, the Village of Villa Park will, after acceptance and approval of the bid for contracting purposes, execute the contract and return a copy to the bidder.

**17.02.** If the contract as bid requires additional execution by the bidder, the contract shall be executed by the successful bidder and returned, together with any required contract bond, within 15 days after the contract has been mailed to

the bidder. Failure of the successful bidder to execute the contract and file acceptable bonds within 15 days after the contract has been mailed to the bidder is cause for the cancellation of the award and the forfeiture of the proposal guaranty. If the contract is not executed by the Village of Villa Park within 15 days following receipt from the bidder of the properly executed contract and bond, the bidder shall have the right to withdraw the bid without penalty.

#### **ARTICLE 18. Contract Times**

**18.01.** Substantial Completion shall be defined as all work, including restoration, excluding punch list items.

**18.02.** All work under this Contract shall be complete to the satisfaction of the Owner as follows:

2019 Sewer Rehabilitation Program - **Substantial Completion within 150 days, and Final Completion within 180 days.**

#### **ARTICLE 19. Project Access and Access To Records**

**19.01.** Every contract entered into by the loan recipient and every sub-agreement hereunder, shall provide that representatives of the Agency (IEPA) will have access to the work whenever it is in preparation or progress and that the contractor or subcontractor will provide proper facilities for such access and inspection.

**19.02.** The contractor shall maintain books, records, documents and other evidence directly pertinent to performance on loan work in accordance with Generally Accepted Accounting Principles (GAAP). The contractor shall also maintain the financial information and data used by the contractor in the preparation or support of any cost submissions required, (Negotiation of Contract Amendments, Change Orders) and a copy of the cost summary submitted to the owner. The Auditor General, the owner, the Agency, or any of their duly authorized representatives shall have access to the books, records, documents, and other evidence for purposes of inspection, audit, and copying. The contractor will provide facilities for such access and inspection.

**19.03.** This contract is a formally advertised, competitively awarded, fixed price contract. The contractor agrees to include access to records as specified in subsection (b) above. This requirement is applicable to all negotiated change orders and contract amendments in excess of \$25,000 that affect the contract price. In the case of all other prime contracts, the contractor also agrees to include access to records as specified above in all his or her contracts and all tier subcontracts or change orders in excess of \$25,000 that are directly related to project performance.

**19.04.** Audits shall be consistent in accordance with auditing standards generally accepted in the United States of America.

**19.05.** The contractor agrees to the disclosure of all information and reports resulting from access to records pursuant to subsection (b) above. Where the audit concerns the contractor, the auditing agency will afford the contractor an

opportunity for an audit exit conference and an opportunity to comment on the pertinent portions of the draft audit report. The final audit report shall include the written comments, if any, of the audited parties.

**19.06.** The records required by subsection (b) above shall be maintained and made available during performance of the work under the loan agreement and for three years after the date of the final loan audit. In addition, records that relate to any dispute or litigation or the settlement of claims arising out of any performance, costs or items to which an audit exception has been taken, shall be maintained and made available for three years after resolution of the dispute, appeal, litigation, claim or exception.

**19.07.** The right of access will generally be exercised with respect to financial records under:

- i. Negotiated prime contracts;
- ii. Negotiated change orders or contract amendments in excess of \$25,000 affecting the price of any formally advertised, competitively awarded, fixed price contract; and
- iii. Subcontracts or purchase orders under any contract other than a formally advertised, competitively awarded, fixed price contract.

**19.08.** The right of access will generally not be exercised with respect to a prime contract, subcontract, or purchase order awarded after effective price competition. In any event, the right of access shall be exercised under any type of contract or subcontract:

- i. With respect to records pertaining directly to contract performance, excluding any financial records of the contractor; and
- ii. If there is any indication that fraud, gross abuse, or corrupt practices may be involved in the award or performance of the contract or subcontract.

## **ARTICLE 20. Funding**

Any Contract Awarded in response to the bid is expected to be funded in part by a loan from the Water Pollution Control Loan Program, and neither the State of Illinois nor any of its departments, agencies or employees will be a party to this bidding or any resulting contract.

## **ARTICLE 21. Disadvantaged Business Enterprise**

Bidder shall not discriminate on the basis of race, color, national origin or sex in the performance of this Contract. The Contractor shall carry out applicable requirements of 40 CFR Part 33 in the award and administration of contracts awarded under EPA financial assistance agreements. Failure by the Contractor to carry out these requirements is a material breach of this contract which may result in the termination of this contract or other legally available remedies.

The Contractor shall provide evidence, including, but not limited to, a copy of the advertisement or advertisements and the record of negotiation, that the contractor has take affirmative steps in accordance with 40 CFR, Part 33 to assure that disadvantaged business enterprises are used when possible as sources of supplies, equipment, construction and services consistent with the provisions of the Agency's Operating Agreement with USEPA.

As part of this Contract Bidders are required to advertise no less than 16 days prior to bid opening for disadvantaged business enterprise participation as sub-contractors. Contractor is to complete the disadvantaged business enterprise participation package in its entirety unless NO sub-contracts will be awarded, in which case the form "Bidder Certification of No Sub-Contracts" shall be completed.

#### **ARTICLE 22. Contractor Bankruptcy**

In the event of a contractor bankruptcy, the loan recipient shall notify the Agency and shall keep the Agency advised of any negotiations with the bonding company, including any proposed settlement. The Agency may participate in those negotiations and will advise the loan recipient of the impact of any proposed settlement to the loan agreement. The loan recipient shall be responsible for assuring that every appropriate procedure and incidental legal requirement is observed in advertising for bids and re-awarding a construction contract.

#### **ARTICLE 23. Remedies**

All claims, counter-claims, disputes and other matters in question between the recipient and the contractor arising out of, or relating to a sub-agreement or its breach shall be decided by arbitration if the parties agree, or in a court of competent jurisdiction within the State.

#### **ARTICLE 24. Subcontracts Under Construction Contracts**

The award or execution of all subcontracts by a prime contractor and the procurement and negotiation procedures used by the prime contractor shall comply with the following:

- i. All applicable provisions of federal and state law;
- ii. All provisions of Illinois Administrative Code Section 365.610 and 365.620 regarding fraud and other unlawful or corrupt practices;
- iii. All provisions of Illinois Administrative Code Section 365.620 with respect to access to facilities, record, and audit of records;
- iv. Submission of "Certification Regarding Debarment, Suspension and Other Responsibility Matters" (EPA Form 5700-49) showing compliance with Executive Order 12549, and "Bidder Certification in Compliance with Article 33E to the Criminal Code of 1961".

#### **ARTICLE 25. Covenant Against Contingent Fees**

The contractor shall warrant that no person or selling agency has been employed or retained to solicit or secure the contract upon an agreement or understanding for a commission, percentage, brokerage, or contingent fee. For breach or violation of this warranty, the owner shall have the right to annul the contract without liability or in its discretion to deduct from the contract price or consideration, or otherwise recover, the full amount of such commission, percentage, brokerage, or contingent fee.

**ARTICLE 26. Minimum Wages. – Davis Bacon Requirements**

(i) All laborers and mechanics employed or working upon the site of the work will be paid unconditionally and not less often than once a week, and without subsequent deduction or rebate on any account (except such payroll deductions as are permitted by regulations issued by the Secretary of Labor under the Copeland Act (29 CFR part 3), the full amount of wages and bona fide fringe benefits (or cash equivalents thereof) due at time of payment computed at rates not less than those contained in the wage determination of the Secretary of Labor which is attached hereto and made a part hereof, regardless of any contractual relationship which may be alleged to exist between the contractor and such laborers and mechanics.

Contributions made or costs reasonably anticipated for bona fide fringe benefits under section 1(b)(2) of the Davis-Bacon Act on behalf of laborers or mechanics are considered wages paid to such laborers or mechanics, subject to the provisions of paragraph (a)(1)(iv) of this section; also regular contributions made or costs incurred for more than a weekly period (but not less than quarterly) under plans, funds, or programs which cover the particular weekly period, are deemed to be constructively made or incurred during such weekly period. Such laborers and mechanics shall be paid the appropriate wage rate and fringe benefits on the wage determination for the classification of work actually performed, without regard to skill, except as provided in 5.5(a)(4). Laborers or mechanics performing work in more than one classification may be compensated at the rate specified for each classification for the time actually worked therein: Provided, that the employer's payroll records accurately set forth the time spent in each classification in which work is performed. The wage determination (including any additional classification and wage rates conformed under paragraph (a)1(ii) of this section) and the Davis- Bacon poster (WH-1321) shall be posted at all times by the contractor and its subcontractors at the site of the work in a prominent and accessible place where it can be easily seen by the workers. Sub recipients may obtain wage determination from the U.S. Department of Labor's web site, [www.wdol.gov](http://www.wdol.gov).

(ii)(A) The sub recipient, on behalf of USEPA, shall require that any class of laborers or mechanics, including helpers, which is not listed in the wage determination and which is to be employed under the contract shall be classified in conformance with the wage determination. The USEPA award official shall approve an additional classification and wage rate and fringe benefits therefore only when the following criteria have been met:

- (1) The work to be performed by the classification requested is not performed by a classification in the wage determination; and
- (2) The classification is utilized in the area by the construction industry; and
- (3) The proposed wage rate, including any bona fide fringe benefits, bears a reasonable relationship to the wage rates contained in the wage determination.

(B) If the contractor and the laborers and mechanics to be employed in the classification (if known), or their representatives, and the sub recipient agree on the classification and wage rate (including the amount designated for fringe benefits where appropriate), a report of the action taken shall be sent by the sub recipient to IEPA. IEPA will transmit the report, to the Administrator of the Wage and Hour Division, Employment Standards Administration, U.S. Department of Labor, Washington, DC 20210. The Administrator, or

an authorized representative, will approve, modify or disapprove every additional classification action within 30 days of receipt and so advise IEPA or notify IEPA within the 30-day period that additional time is necessary.

(C) In the event the contractor, the laborers or mechanics to be employed in the classification or their representatives, and the sub recipient do not agree on the proposed classification and wage rate (including the amount designated for fringe benefits, where appropriate), the award official shall refer the questions, including the views of all interested parties and the recommendation of the award official, to the Administrator for determination. The Administrator, or an authorized representative, will issue a determination within 30 days of receipt and so advise the contracting officer or will notify the contracting officer within the 30-day period that additional time is necessary.

(D) The wage rate (including fringe benefits where appropriate) determined pursuant to paragraphs (a)(1)(ii)(B) or (C) of this section, shall be paid to all workers performing work in the classification under this contract from the first day on which work is performed in the classification.

(iii) Whenever the minimum wage rate prescribed in the contract for a class of laborers or mechanics includes a fringe benefit which is not expressed as an hourly rate, the contractor shall either pay the benefit as stated in the wage determination or shall pay another bona fide fringe benefit or an hourly cash equivalent thereof.

(iv) If the contractor does not make payments to a trustee or other third person, the contractor may consider as part of the wages of any laborer or mechanic the amount of any costs reasonably anticipated in providing bona fide fringe benefits under a plan or program. Provided, that the Secretary of Labor has found, upon the written request of the contractor, that the applicable standards of the Davis-Bacon Act have been met. The Secretary of Labor may require the contractor to set aside in a separate account assets for the meeting of obligations under the plan or program.

(2) Withholding, the sub recipient shall upon written request of the USEPA Award Official or an authorized representative of the Department of Labor withhold or cause to be withheld from the contractor under this contract or any other Federal contract with the same prime contractor, or any other federally-assisted contract subject to Davis-Bacon prevailing wage requirements, which is held by the same prime contractor, so much of the accrued payments or advances as may be considered necessary to pay laborers and mechanics, including apprentices, trainees, and helpers, employed by the contractor or any subcontractor the full amount of wages required by the contract. In the event of failure to pay any laborer or mechanic, including any apprentice, trainee, or helper, employed or working on the site of the work, all or part of the wages required by the contract, the (Agency) may, after written notice to the contractor, sponsor, applicant, or owner, take such actions as may be necessary to cause the suspension of any further payment, advance, or guarantee of funds until such violations have ceased.

(3) Payrolls and basic records.

(i) Payrolls and basic records relating thereto shall be maintained by the contractor during the course of the work and preserved for a period of three years thereafter for all laborers and mechanics working at the site of the work. Such records shall contain the name, address, and social security number of each such worker, his or her correct

classification, hourly rates of wages paid (including rates of contributions or costs anticipated for bona fide fringe benefits or cash equivalents thereof of the types described in section 1(b)(2)(B) of the Davis-Bacon Act), daily and weekly number of hours worked, deductions made and actual wages paid. Whenever the Secretary of Labor has found under 29 CFR 5.5(a)(1)(iv) that the wages of any laborer or mechanic include the amount of any costs reasonably anticipated in providing benefits under a plan or program described in section 1(b)(2)(B) of the Davis-Bacon Act, the contractor shall maintain records which show that the commitment to provide such benefits is enforceable, that the plan or program is financially responsible, and that the plan or program has been communicated in writing to the laborers or mechanics affected, and records which show the costs anticipated or the actual cost incurred in providing such benefits. Contractors employing apprentices or trainees under approved programs shall maintain written evidence of the registration of apprenticeship programs and certification of trainee programs, the registration of the apprentices and trainees, and the ratios and wage rates prescribed in the applicable programs.

(ii)(A) The contractor shall submit weekly for each week in which any contract work is performed a copy of all payrolls to the sub recipient, that is, the entity that receives the sub-grant or loan from IEPA. Such documentation shall be available on request of IEPA or USEPA. The payrolls shall set out accurately and completely all of the information required to be maintained under 29 CFR 5.5(a)(3)(i), except that full social security numbers and home addresses shall not be included on the weekly payrolls. Instead the payrolls shall only need to include an individually identifying number for each employee (e.g., the last four digits of the employee's social security number). Form WH-347 is available for this purpose from the Wage and Hour Division Web site at <http://www.dol.gov/esa/whd/forms/wh347instr.htm> or its successor site. The prime contractor is responsible for the submission of copies of payrolls by all subcontractors. Contractors and subcontractors shall maintain the full social security number and current address of each covered worker, and shall provide them upon request to the sub recipient for transmission to IEPA or USEPA, if requested, for purposes of an investigation or audit of compliance with prevailing wage requirements. It is not a violation of this section for a prime contractor to require a subcontractor to provide addresses and social security numbers to the prime contractor for its own records, without weekly submission to the sub recipient.

(B) Each payroll submitted shall be accompanied by a "Statement of Compliance," signed by the contractor or subcontractor or his or her agent who pays or supervises the payment of the persons employed under the contract and shall certify the following:

(1) That the payroll for the payroll period contains the information required to be provided under 5.5 (a)(3)(ii) of Regulations, 29 CFR Part 5, the appropriate information is being maintained under 5.5 (a)(3)(i) of Regulations, 29 CFR Part 5, and that such information is correct and complete.

(2) That each laborer and mechanic (including each helper, apprentice, and trainee) employed on the contract during the payroll period has been paid the full weekly wages earned, without rebate, either directly or indirectly, and that no deductions have been made either directly or indirectly from the full wages earned, other than permissible deductions as set forth in Regulations, 29 CFR Part 3;

(3) That each laborer or mechanic has been paid not less than the applicable wage rates and fringe benefits or cash equivalents for the classification of work performed, as

specified in the applicable wage determination incorporated into the contract.

(C) The weekly submission of a properly executed certification set forth on the reverse side of optional Form WH-347, available for this purpose from the Wage and Hour Division Web site at <http://www.dol.gov/esa/whd/forms/wh347instr.htm> or its successor site, shall satisfy the requirement for submission of the "Statement of Compliance" required by paragraph (a)(3)(ii)(B) of this section.

(D) The falsification of any of the above certifications may subject the contractor or subcontractor to civil or criminal prosecution under section 1001 of title 18 and section 231 of title 31 of the United States Code.

(iii) The contractor or subcontractor shall make the records required under paragraph (a)(3)(i) of this section available for inspection, copying, or transcription by authorized representatives of IEPA, USEPA or the Department of Labor, and shall permit such representatives to interview employees during working hours on the job. If the contractor or subcontractor fails to submit the required records or to make them available, the Federal agency or IEPA may, after written notice to the contractor, sponsor, applicant, or owner, take such action as may be necessary to cause the suspension of any further payment, advance, or guarantee of funds. Furthermore, failure to submit the required records upon request or to make such records available may be grounds for debarment action pursuant to 29 CFR 5.12.

(4) Apprentices and trainees –

(i) Apprentices. Apprentices will be permitted to work at less than predetermined rate for the work they performed when they are employed pursuant to and individually registered in a bona fide apprenticeship program registered with the U.S. Department of Labor, Employment and Training Administration, Office of Apprenticeship Training, Employer and Labor Services, or with a State Apprenticeship Agency recognized by the Office, or if a person is employed in his or her first 90 days of probationary employment as an apprentice in such an apprenticeship program, who is not individually registered in the program, but who has been certified by the Office of Apprenticeship Training, Employer and Labor Services or a State Apprenticeship Agency (where appropriate) to be eligible for probationary employment as an apprentice. The allowable ratio of apprentices to journeymen on the job site in any craft classification shall not be greater than the ratio permitted to the contractor as to the entire work force under the registered program. Any worker listed on a payroll at an apprentice wage rate, who is not registered or otherwise employed as stated above, shall be paid not less than the applicable wage rate on the wage determination for the classification of work actually performed. In addition, any apprentice performing work on the job site in excess of the ratio permitted under the registered program shall be paid not less than the applicable wage rate on the wage determination for the work actually performed. Where a contractor is performing construction on a project in a locality other than that in which its program is registered, the ratios and wage rates (expressed in percentages of the journeyman's hourly rate) specified in the contractor's or subcontractor's registered program shall be observed. Every apprentice must be paid at not less than the rate specified in the registered program for the apprentice's level of progress, expressed as a percentage of the journeymen hourly rate specified in the applicable wage determination.

Apprentices shall be paid fringe benefits in accordance with the provisions of the apprenticeship program. If the apprenticeship program does not specify fringe benefits,

apprentices must be paid the full amount of fringe benefits listed on the wage determination for the applicable classification. If the Administrator determines that a different practice prevails for the applicable apprentice classification, fringes shall be paid in accordance with that determination. In the event the Office of Apprenticeship Training, Employer and Labor Services, or a State Apprenticeship Agency recognized by the Office, withdraws approval of an apprenticeship program, the contractor will no longer be permitted to utilize apprentices at less than the applicable predetermined rate for the work performed until an acceptable program is approved.

(ii) Trainees. Except as provided in 29 CFR 5.16, trainees will not be permitted to work at less than the predetermined rate for the work performed unless they are employed pursuant to and individually registered in a program which has received prior approval, evidenced by formal certification by the U.S. Department of Labor, Employment and Training Administration. The ratio of trainees to journeymen on the job site shall not be greater than permitted under the plan approved by the Employment and Training Administration. Every trainee must be paid at not less than the rate specified in the approved program for the trainee's level of progress, expressed as a percentage of the journeyman hourly rate specified in the applicable wage determination. Trainees shall be paid fringe benefits in accordance with the provisions of the trainee program. If the trainee program does not mention fringe benefits, trainees shall be paid the full amount of fringe benefits listed on the wage determination unless the Administrator of the Wage and Hour Division determines that there is an apprenticeship program associated with the corresponding journeyman wage rate on the wage determination which provides for less than full fringe benefits for apprentices. Any employee listed on the payroll at a trainee rate who is not registered and participating in a training plan approved by the Employment and Training Administration shall be paid not less than the applicable wage rate on the wage determination for the classification of work actually performed. In addition, any trainee performing work on the job site in excess of the ratio permitted under the registered program shall be paid not less than the applicable wage rate on the wage determination for the work actually performed. In the event the Employment and Training Administration withdraws approval of a training program, the contractor will no longer be permitted to utilize trainees at less than the applicable predetermined rate for the work performed until an acceptable program is approved.

(iii) Equal employment opportunity. The utilization of apprentices, trainees and journeymen under this part shall be in conformity with the equal employment opportunity requirements of Executive Order 11246, as amended, and 29 CFR part 30.

(5) Compliance with Copeland Act requirements. The contractor shall comply with the requirements of 29 CFR Part 3, which are incorporated by reference in this contract.

(6) Subcontracts. The contractor or subcontractor shall insert in any subcontracts the clauses contained in 29 CFR 5.5(a)(1) through (10) and such other clauses as the USEPA determines may be appropriate, and also a clause requiring the subcontractors to include these clauses in any lower tier subcontracts.

The prime contractor shall be responsible for the compliance by any subcontractor or lower tier subcontractor with all the contract clauses in 29 CFR 5.5.

(7) Contract termination: debarment. A breach of the contract clauses in 29 CFR 5.5 may be grounds for termination of the contract, and for debarment as a contractor and a subcontractor as provided in 29 CFR 5.12.

(8) Compliance with Davis-Bacon and Related Act requirements. All rulings and interpretations of the Davis-Bacon and Related Acts contained in 29 CFR parts 1, 3, and 5 are herein incorporated by reference in this contract.

(9) Disputes concerning labor standards. Disputes arising out of the labor standards provisions of this contract shall not be subject to the general disputes clause of this contract. Such disputes shall be resolved in accordance with the procedures of the Department of Labor set forth in 29 CFR parts 5, 6, and 7. Disputes within the meaning of this clause include disputes between the contractor (or any of its subcontractors) and sub recipients, IEPA, USEPA, the U.S. Department of Labor, or the employees or their representatives.

(10) Certification of eligibility.

(i) By entering into this contract, the contractor certifies that neither it (nor he or she) nor any person or firm who has an interest in the contractor's firm is a person or firm ineligible to be awarded Government contracts by virtue of section 3(a) of the Davis-Bacon Act or 29 CFR 5.12(a)(1).

(ii) No part of this contract shall be subcontracted to any person or firm ineligible for award of a Government contract by virtue of section 3(a) of the Davis-Bacon Act or 29 CFR 5.12(a)(1).

(iii) The penalty for making false statements is prescribed in the U.S. Criminal Code, 18 U.S.C.1001.

#### **ARTICLE 27. Weekly Wage Reporting**

**27.01.** These requirements apply to all Contracts, Subcontracts, and Sub-subcontracts in excess of \$2,000.

**27.02.** Certified weekly payroll identifying all field personnel, hours worked, labor rate, fringe benefits is to be provided to the General Contractor on a weekly basis.

**27.03.** It is recommended that DOL form wh347 be used for this purpose although its use is optional. It can be found at: <http://www.dol.gov/whd/programs/dbra/wh347.htm> . Also required is a weekly "Statement of Compliance" (reverse of Form 347 is already set-up for this).

**27.04.** The General Contractor is to forward certified payroll for his own employees; the reports from the subcontractors, any sub-subcontractors (with contracts in excess of \$2,000) to the Village on a weekly basis.

**27.05.** Records are to maintained by all parties for three (3) years from completion of the Contract.

**27.06.** Davis Bacon IL-11 (Heavy Civil) or DuPage County prevailing wage whichever is higher shall take precedence.

**27.06.1.** Davis Bacon Poster with the prevailing wages attached shall be posted at the job site. The poster can be found at: <http://www.dol.gov/whd/programs/dbra/wh1321.htm>. In the event that there is no field office locations shall be identified that will comply with Federal Regulations for the Contractor and each sub-contractor.

**27.06.2.** The Village or his representative (Engineer) is required to conduct on-site interviews to verify personnel, hours worked and pay rates. These will occur at a minimum for the first pay request and the last pay request. The interviews are to be conducted without presence of management and the findings are reported to IEPA. The interview form can be found at: <http://www.gsa.gov/portal/forms/download/115910>.

#### **ARTICLE 28. Iron and Steel Products**

Contractor shall comply with Sec. 436 of H.R. 3547, "The Consolidated Appropriations Act, 2014", which specifies that all "iron and steel products" used in the project are produced in the United States.

#### **ARTICLE 29. Debarment and suspension provisions**

The contract shall require the successful bidder or bidders to submit a "Certificate Regarding Debarment, Suspension and Other Responsibilities Matters" (EPA Form 5700-49) showing compliance with federal Executive Order 12549 (Appendix A, Exhibit C).

#### **ARTICLE 30. Non-segregated facilities provisions**

The successful bidder shall be required to submit a certification of non-segregated facilities as prescribed by USC 1001.

#### **ARTICLE 31. Negotiations of Contract Amendments (Change Orders)**

**31.01.** The successful bidder shall comply with the following as prescribed by USC 1001.

Illinois Administrative Code Title 35

Section 365.620(c) Negotiations of Contract Amendments (Change Orders)

**31.02.** Changes in contract price or time

The contract price or time may be changed only by a change order. When negotiations are required, they shall be conducted in accordance with subsection (c) of this section.

**31.03.** For each change order the contractor shall submit to the loan recipient for review sufficient cost and pricing data to enable the loan recipient to ascertain the necessity and reasonableness of costs and amounts proposed, and the allowability and eligibility of costs proposed.

**BID FOR**  
**2019 SEWER REHABILITATION PROGRAM**  
**VILLAGE OF VILLA PARK, DUPAGE COUNTY, ILLINOIS**  
VILLA PARK, ILLINOIS 60181

In accordance with the contract documents, the undersigned Contractor hereby proposes to perform everything required; to provide and furnish all of the labor, materials (expendable and otherwise), tools, equipment, plant and other necessary apparatus, and all transporting services required to perform and complete within the completion time stated herein, all work for the **2019 SEWER REHABILITATION PROGRAM** as stated in the scope of work included and in accordance with the contract documents, and at the price stated hereinafter.

The undersigned Contractor declares that it has, before submitting this proposal, carefully examined the contract documents, addenda (if any), and exhibits (if any); inspected in detail the site(s) of the proposed work; familiarized itself as to the work to be done; investigated and become familiar with all the local conditions affecting the contract and is fully acquainted with the detailed requirements of the construction. By submitting this proposal the undersigned conclusively assures and warrants to the Village of Villa Park that the undersigned has made these examinations and that the undersigned understands all requirements for the performance of the work. If the undersigned's proposal is accepted, the undersigned agrees to be responsible for all errors in the proposal resulting from the undersigned's failure or neglect to comply with the Instructions for Bidders and agrees that the Village of Villa Park will, in no case, be responsible for any costs, expenses, losses, or change in anticipated profits resulting from such failure or neglect of the undersigned to make these examinations.

A proposal guaranty in the form of a bid bond, executed by a corporate surety company, a bank cashier's check or a certified check payable to the Village of Villa Park in the amount of 5% (\$ \_\_\_\_\_) (not less than five percent (5%) of the amount bid) in accordance with the requirements of the Instructions to Bidders accompanies this proposal.

The undersigned Contractor agrees that, upon receipt of written notice of acceptance of its proposal, it will furnish all required bonds and insurance, and will execute a contract, commence work, and perform all other functions as stated in the contract documents. If this proposal is accepted and the undersigned Contractor fails to execute the contract, it is hereby agreed that the Bid Bond or proposal guaranty check shall be forfeited to the Village of Villa Park.

The undersigned Contractor declares that any and all prices stated in the proposal include all taxes; costs of plant, labor, and materials; insurance; overhead and profit; and any and all other costs normal to doing business.

The undersigned Contractor declares that this proposal shall remain in force for a period of ninety (90) days from the date of this proposal.

The undersigned Contractor declares that it understands that the quantities shown herein are approximate only and that they are subject to increase or decrease; and agrees that it will take, in full payment, the amount of the summation of the actual quantities, as finally determined, multiplied by the unit prices shown on the schedule of prices forming a part of this proposal.

BIDDER acknowledges receipt of the following ADDENDUM:

\_\_\_\_\_  
\_\_\_\_\_  
\_\_\_\_\_

The undersigned Contractor acknowledges receipt of the following addenda:

No.   1   Dated:   July 25, 2019    
No. \_\_\_\_\_ Dated: \_\_\_\_\_  
No. \_\_\_\_\_ Dated: \_\_\_\_\_

The undersigned Contractor submits the following schedule of unit prices covering the work to be performed under the contract and agrees to complete the work for the unit prices set forth in the schedule.

The undersigned Contractor agrees to complete the work substantially within **150 days** and completely within **180 days** after the date the Village gives the Contractor written notice to proceed.

BIDDER certifies that all iron and steel products used in the project for the construction, alteration, maintenance, or repair of a public water system are produced in the United States in compliance with Section 436. (a) – (f) of H. R. 3547, "The Consolidated Appropriation Act, 2014".

By submission of the bid, each bidder certifies, and in the case of a joint bid each party thereto certifies as to his own organization, that in connection with the bid:

- i. The prices in the bid have been arrived at independently, without consultation, communication, or agreement, for the purpose of restricting competition, as to any matter relating to such prices with any other bidder or with any competitor;
- ii. Unless otherwise required by law, the prices which have been quoted in the bid have not knowingly been disclosed by the bidder, prior to opening, directly or indirectly to any other bidder or to any competitor; and
- iii. No attempt has been made or will be made by the bidder to induce any other person or firm to submit or not to submit a bid for the purpose of restricting competition.

Each person signing the bid shall certify that:

- i. He is the person in the bidder's organization responsible within that organization for the decision as to the prices being bid and that he has not participated, and will not participate, in any action contrary to (I) (i) through (I)(iii) above; or
- ii. He is not the person in the bidder's organization responsible within that organization for the decision as to the prices being bid but that he has been authorized to act as agent for the persons responsible for such decision in certifying that such persons have not participated, and will not participate, in any action contrary to (I)(i) through (I)(iii) above, and as their agent shall so certify; and shall also certify that he has not participated, and will not participate, in any action contrary to (I)(i) through (I)(iii) above.

The following documents are attached to and made a condition of this bid:

(a) Required Bid Security in the form of:

\_\_\_\_\_ (Certified Check or **Bid Bond**)

In the amount of: \_\_\_\_\_ 5%  
(Dollars or Percent)

(b) A tabulation of Subcontractors and other persons and organizations required to be identified in this Bid in accordance with state laws applicable where the Work is to be performed.

(c) Statement of the Bidder's qualification to do business in the State of Illinois.

Communications concerning this Bid shall be addressed to the Bidder as indicated below:

NAME: Mike Figlio

ADDRESS: 817 Main Street

CITY, STATE: Brownsville, WI 53006

TELEPHONE NO: 920-924-4300

FAX NO: 920-924-4323

EMAIL: ,mfiglio@michels.us

The terms used in this Bid which are defined in the General Conditions of the Construction Contract included as part of the Contract Documents have the meanings assigned to them in the General Conditions.

Michels Pipe Services; dba Michels Corporation, having submitted a bid on a contract  
(Name of Contractor)

for the **2019 SEWER REHABILITATION PROGRAM**, as generally described in the Advertisement for Bids, to the Village of Villa Park, hereby certifies that said contractor is not barred from bidding on the aforementioned contract as a result of a violation of either Section 33E-3 or 33E-4 of Article 33E of Chapter 720 of the ILLINOIS Compiled Statutes (70 ILCS 5/33E-3 and 5/33E-4).

By: [Signature]  
Authorized Agent of Contractor

Subscribed and sworn to before me  
This 29th day of July, 2019

[Signature]  
Notary Public

SUBMITTED ON July 29, 2019

CONTRACTOR'S LICENSE NO. 5649-392-1

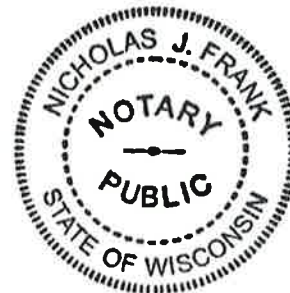

(If a partnership):

Partnership's Name \_\_\_\_\_

Street Address \_\_\_\_\_

City State Zip Code \_\_\_\_\_

Telephone Number \_\_\_\_\_

**Signature of General Partner** \_\_\_\_\_

(If a corporation):

Michels Corporation  
Corporate Name \_\_\_\_\_

817 Main Street  
Street Address \_\_\_\_\_

Brownsville WI 53006  
City State Zip Code \_\_\_\_\_

9201-924-4300  
Telephone Number \_\_\_\_\_

Mike Figlio  
Name of President Regional Manager Pipe Services

  
**Signature of President** Regional Manager Pipe Services

Angela Muser  
Name of Secretary Admin Assistant Pipe Services

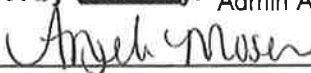
**Attest by Secretary:** Admin Assistant Pipe Services  



## BID SCHEDULE FOR

## 2019 SEWER REHABILITATION PROGRAM

BIDDER agrees to perform all the work described on the CONTRACT DOCUMENTS for the following unit prices or lump sum.

NOTE: BIDS shall include sales tax and all other applicable taxes.

**BASE BID:**

Item No.	Items	Unit	Quantity	Unit Price	Total
1	PRE-CONSTRUCTION SURFACE TELEVISIONING	LS	1	13,273.20	13,273.20
2	PRE-CONSTRUCTION SEWER CLEANING AND TELEVISIONING	LF	22,000	3.80	83,600.00
3	LATERAL CLEANING AND TELEVISIONING	EACH	2	360.80	721.60
4	CURED-IN-PLACE SEWER LINER, 8" DIAMETER	LF	13,100	21.30	279,030.00
5	CURED-IN-PLACE SEWER LINER, 10" DIAMETER	LF	8,000	21.90	175,200.00
6	CURED-IN-PLACE SEWER LINER, 15" DIAMETER	LF	300	55.30	16,590.00
7	CURED-IN-PLACE SEWER LINER, 18" DIAMETER	LF	255	84.90	21,649.50
8	CURED-IN-PLACE SEWER LINER, 21" DIAMETER	LF	345	81.60	28,152.00
9	INTERNAL SERVICE LATERAL REINSTATEMENT	EACH	510	107.40	54,774.00
10	PROTRUDING TAP REMOVAL	EACH	20	198.30	3,966.00
11	DYE TESTING OF EXISTING SERVICE CONNECTIONS	EACH	50	519.90	25,995.00
12	AIR TEST AND GROUT SERVICE CONNECTION	EACH	95	533.90	50,720.50
13	T-LINER INSTALLATION, 8" x 6"	EACH	2	5,824.70	11,649.40
14	ADDITIONAL LATERAL LINER	LF	10	103.10	1,031.00
15	POINT REPAIR JOB NO. 1	LS	1	17,010.30	17,010.30
16	POINT REPAIR JOB NO. 2	LS	1	25,773.20	25,773.20
17	POINT REPAIR JOB NO. 3	LS	1	22,680.40	22,680.40
18	POINT REPAIR JOB NO. 4	LS	1	17,010.30	17,010.30
19	EMERGENCY POINT REPAIR, 8" or 10" DIAMETER, UP TO 10' IN LENGTH, UP TO 10' DEEP, PUBLIC ROW	LS	1	14,381.40	14,381.40

***This page intentionally left blank.***

Item No.	Items	Unit	Quantity	Unit Price	Total
19a	EMERGENCY POINT REPAIR, 8" or 10" DIAMETER, UP TO 10' IN LENGTH, UP TO 10' DEEP, BACKYARD	LS	1	22,680.40	22,680.40
20	EMERGENCY POINT REPAIR, 8" or 10" DIAMETER, UP TO 10' IN LENGTH, FROM 10' TO 15' DEEP, PUBLIC ROW	LS	1	18,453.60	18,453.60
20a	EMERGENCY POINT REPAIR, 8" or 10" DIAMETER, UP TO 10' IN LENGTH, FROM 10' TO 15' DEEP, BACKYARD	LS	1	25,773.20	25,773.20
21	ADDITIONAL 8" SANITARY SEWER	LF	10	25.80	258.00
22	ADDITIONAL 6" SANITARY LATERAL	LF	10	15.50	155.00
23	ADDITIONAL SERVICE CONNECTION REPAIR (WITHIN TRENCH)	EACH	1	206.20	206.20
24	NEW LATERAL SERVICE INSTALLATION FROM NEW CLEANOUT TO EXISTING MANHOLE (20-FT DRILL APPROX.)	EACH	1	34,577.30	34,577.30
25	REPLACE COVER	EACH	10	232.00	2,320.00
26	REPLACE FRAME AND COVER (UNPAVED)	EACH	10	2,732.00	27,320.00
27	SEAL AND ADJUST MANHOLE FRAME (UNPAVED)	EACH	4	2,422.70	9,690.80
28	UNCOVER AND RAISE BURIED MANHOLE (UNPAVED)	EACH	1	3,489.70	3,489.70
29	INTERNAL CHIMNEY SEAL	EACH	15	431.80	6,477.00
30	CURTAIN GROUT MANHOLE	EACH	6	1,655.40	9,932.40
31	GROUT WALL JOINTS	EACH	25	275.30	6,882.50
32	CURTAIN GROUT BOTTOM 18 INCHES	EACH	25	1,196.50	29,912.50
33	CEMENTITIOUS MANHOLE SEALING - 48" DIA MANHOLE	VF	240	258.40	62,016.00
34	REPAIR BENCH AND TROUGH	EACH	5	683.20	3,416.00
35	REPLACE BENCH AND TROUGH	EACH	2	1,681.60	3,363.20
36	VACUUM TESTING	EACH	8	606.80	4,854.40

*This page intentionally left blank.*

Item No.	Items	Unit	Quantity	Unit Price	Total
37	WATER USAGE DEDUCTION	TGAL	100	- \$8.85	-\$885.00
38	WATER USAGE CREDIT	TGAL	100	\$8.85	\$885.00
39	PROJECT MANAGEMENT	LS	1	6,919.50	6,919.50
40	TRAFFIC CONTROL AND PROTECTION	LS	1	14,135.20	14,135.20
<b>TOTAL BASE BID</b>					<b>\$1,156,040.70</b>

**TOTAL BASE BID**.....**One Million One Hundred Fifty Six Thousand Forty Dollars and Seventy Cents**  
**(in writing)**

*This page intentionally left blank.*

**ALTERNATE NO. 1 INCLUDING ADDITIONAL SEWER LINING WORK:**

Item No.	Items	Unit	Quantity	Unit Price	Total
A.1	PRE-CONSTRUCTION SURFACE TELEVISIONING	LS	1	2,046.40	2,046.40
A.2	PRE-CONSTRUCTION SEWER CLEANING AND TELEVISIONING	LF	3,500	3.00	10,500.00
A.3	CURED-IN-PLACE SEWER LINER, 8" DIAMETER	LF	750	21.80	16,350.00
A.4	CURED-IN-PLACE SEWER LINER, 10" DIAMETER	LF	2,750	22.20	61,050.00
A.5	INTERNAL SERVICE LATERAL REINSTATEMENT	EA	85	109.70	9,324.50
A.6	PROTRUDING TAP REMOVAL	EA	10	194.40	1,944.00
A.7	DYE TESTING OF EXISTING SERVICE CONNECTIONS	EA	10	526.20	5,262.00
<b>TOTAL ALTERNATE NO. 1 BID</b>					<b>\$106,476.90</b>

**TOTAL ALTERNATE NO. 1 BID**.....  
**(in writing)**

*This page intentionally left blank.*

**BID BOND**

KNOW ALL MEN BY THESE PRESENTS, that we the undersigned, \_\_\_\_\_  
 \_\_\_\_\_ Michels Corporation \_\_\_\_\_ as Principal, and  
 \_\_\_\_\_ Continental Casualty Company \_\_\_\_\_ as Surety, are hereby held and firmly bound  
 unto \_\_\_\_\_ Village of Villa Park \_\_\_\_\_ as OWNER in the penal sum of  
 \_\_\_\_\_ Five Percent of Amount Bid (5%) \_\_\_\_\_ for the payment of which, well and truly to be made,  
 we hereby jointly and severally bind ourselves, successors and assigns.

Signed, this 30th day of July, 2019.

The Condition of the above obligation is such that whereas the Principal has submitted to  
 \_\_\_\_\_ Village of Villa Park \_\_\_\_\_ a certain BID, attached hereto and  
 hereby made a part hereof to enter into a contract in writing, for the  
 \_\_\_\_\_ 2019 Sewer Rehabilitation Program \_\_\_\_\_  
 \_\_\_\_\_  
 \_\_\_\_\_  
 \_\_\_\_\_

**NOW, THEREFORE,**

- (a) If said BID shall be rejected, or
- (b) If said BID shall be accepted and the Principal shall execute and deliver a contract in the Form of Contract attached hereto (properly completed in accordance with said BID) and shall furnish a BOND for his faithful performance of said contract, and for the payment of all persons performing labor or furnishing materials in connection therewith, and shall in all other respects perform the agreement created by the acceptance of said BID, then this obligation shall be void, otherwise the same shall remain in force and effect; it being expressly understood and agreed that the liability of the Surety for any and all claims hereunder shall, in no event, exceed the penal amount of this obligation as herein stated.

**OWNER COPY**

**CONTRACT**

The Surety, for value received, hereby stipulates and agrees that the obligations of said Surety and its BOND shall be in no way impaired or affected by any extension of the time within which the OWNER may accept such bid; and said Surety does hereby waive notice of any such extension.

IN WITNESS WHEREOF, the Principal and Surety have hereunto set their hands and seals, and such of them as are corporations have caused their corporate seals to be hereto affixed and these presents to be signed by their proper officers, the day and year first set forth above.

Michels Corporation

  
\_\_\_\_\_  
Principal-Regional Manager  
Pipe Service



Continental Casualty Company  
Surety

By:   
Heather R. Goedtel, Attorney-in-Fact

IMPORTANT-Surety companies executing BONDS must appear on the Treasury Department's most current list (Circular 570 as amended) and be authorized to transact business in the salute where the project is located.

**OWNER COPY**

**CONTRACT**

# Surety Acknowledgment

---

State of Minnesota }  
County of Hennepin } ss.

On this 30<sup>th</sup> day of July 2019, before me personally came Heather R. Goedel, to me known, who being by me duly sworn, did depose and say that she is the Attorney-in-Fact of Continental Casualty Company described in and which executed the above instrument; that she/he knows the seal of said corporation; that the seal affixed to said instruments is such corporate seal, that it was so affixed by order of the Board of Directors of said corporation, and that she/he signed her/she/his name to it by like order.



  
\_\_\_\_\_  
Notary Public

**OWNER COPY**

**CONTRACT**

POWER OF ATTORNEY APPOINTING INDIVIDUAL ATTORNEY-IN-FACT

Know All Men By These Presents, That Continental Casualty Company, an Illinois insurance company, National Fire Insurance Company of Hartford, an Illinois insurance company, and American Casualty Company of Reading, Pennsylvania, a Pennsylvania insurance company (herein called "the CNA Companies"), are duly organized and existing insurance companies having their principal offices in the City of Chicago, and State of Illinois, and that they do by virtue of the signatures and seals herein affixed hereby make, constitute and appoint

Brian D. Carpenter, Jessica Hoff, Nicole Langer, Craig Olmstead, Trisha Kasper, Blake S. Bohlgl, Kelly Nicole Bruggeman, Heather R. Goedel, Michelle Halter, Individually

of Bloomington, MN, their true and lawful Attorney(s)-in-Fact with full power and authority hereby conferred to sign, seal and execute for and on their behalf bonds, undertakings and other obligatory instruments of similar nature

- In Unlimited Amounts -

and to bind them thereby as fully and to the same extent as if such instruments were signed by a duly authorized officer of their insurance companies and all the acts of said Attorney, pursuant to the authority hereby given is hereby ratified and confirmed.

This Power of Attorney is made and executed pursuant to and by authority of the By-Law and Resolutions, printed on the reverse hereof, duly adopted, as indicated, by the Boards of Directors of the insurance companies.

In Witness Whereof, the CNA Companies have caused these presents to be signed by their Vice President and their corporate seals to be hereto affixed on this 22nd day of February, 2019.



Continental Casualty Company
National Fire Insurance Company of Hartford
American Casualty Company of Reading, Pennsylvania

Paul T. Bruflat
Vice President

State of South Dakota, County of Minnehaha, ss:

On this 22nd day of February, 2019, before me personally came Paul T. Bruflat to me known, who, being by me duly sworn, did depose and say: that he resides in the City of Sioux Falls, State of South Dakota; that he is a Vice President of Continental Casualty Company, an Illinois insurance company, National Fire Insurance Company of Hartford, an Illinois insurance company, and American Casualty Company of Reading, Pennsylvania, a Pennsylvania insurance company described in and which executed the above instrument; that he knows the seals of said insurance companies; that the seals affixed to the said instrument are such corporate seals; that they were so affixed pursuant to authority given by the Boards of Directors of said insurance companies and that he signed his name thereto pursuant to like authority, and acknowledges same to be the act and deed of said insurance companies.



My Commission Expires June 23, 2021

J. Mohr
Notary Public

CERTIFICATE

I, D. Johnson, Assistant Secretary of Continental Casualty Company, an Illinois insurance company, National Fire Insurance Company of Hartford, an Illinois insurance company, and American Casualty Company of Reading, Pennsylvania, a Pennsylvania insurance company do hereby certify that the Power of Attorney herein above set forth is still in force, and further certify that the By-Law and Resolution of the Board of Directors of the insurance companies printed on the reverse hereof is still in force. In testimony whereof I have hereunto subscribed my name and affixed the seal of the said insurance companies this 30th day of July, 2019.



Continental Casualty Company
National Fire Insurance Company of Hartford
American Casualty Company of Reading, Pennsylvania

D. Johnson
Assistant Secretary

Form F6853-4/2012

**OWNER COPY**

**CONTRACT**

**CONTRACTOR'S CERTIFICATION**

The assurances hereinafter made by the Contractor are each a material representation of fact upon which reliance is placed by the Village of Villa Park in entering into the contract with the Contractor. The Village of Villa Park may terminate the contract if it is later determined that the Contractor rendered a false or erroneous assurance, and the surety providing the performance bond shall be responsible for the completion of the contract.

I, Mike Figlio, hereby certify that I am the Regional Manager Pipe Services of  
*(Name of Owner or Officer)* *(Title or Office)*  
Michels Pipe Services; a division of Michels Corporation, and as such, hereby represent and warrant to the Village of  
*(Name of Contractor)*  
Villa Park, a municipal corporation, that the Contractor and its shareholders holding more than five percent (5%) of the outstanding shares of the corporation, its officers and directors are:

- A. not delinquent in the payment of taxes to the Illinois Department of Revenue in accordance with 65 ILCS 5/11-42.1-1;
- B. not barred from contracting as a result of a violation of either Section 33E-3 (bid rigging) or 33E-4 (bid-rotating) of the Criminal Code of 1961 (720 ILCS 5/33E-3 and 5/33E-4);
- C. not in default, as defined in 5ILCS 385/2, on an educational loan, as defined in 5ILCS 385/1;

In addition, the Contractor hereby represents and warrants to the Village of Villa Park, that:

- A. the Contractor has and will comply with all laws relating to the payment of general prevailing wages in accordance with the Illinois Prevailing Wage Act (820 ILCS 130/0.01 *et seq.*);
- B. the Contractor has and will comply with all laws relating to the employment preference to veterans in accordance with the Veterans Preference Act (330 ILCS 55/0.01 *et seq.*);
- C. the Contractor has and will comply with all laws relating to the employment of Illinois workers in accordance with the Employment of Illinois Workers on Public Works Act (30 ILCS 570/1 *et seq.*);
- D. the Contractor, pursuant to 30 ILCS 580/1 *et seq.* (Drug-Free Workplace Act), will provide a drug-free workplace by:

1. Publishing a statement:

- a. Notifying employees that the unlawful manufacture, distribution, dispensation, possession, or use of a controlled substance including cannabis, is prohibited in the Contractor's workplace;
- b. Specifying the actions that will be taken against employees for violations of such prohibition;
- c. Notifying the employee that, as a condition of employment on such Contract, the employee will:
  - i. Abide by the terms of the statement;
  - ii. Notify the employer of any criminal drug statute conviction for a violation occurring in the workplace no later than five (5) days after such conviction;

**OWNER COPY**

**CONTRACT**

2. Establishing a drug-free awareness program to inform employees about:
  - a. the dangers of drug abuse in the workplace;
  - b. the Contractor's policy of maintaining a drug-free workplace;
  - c. any available drug counseling, rehabilitation, and employee assistance program; and
  - d. the penalties that may be imposed upon employees for drug violations;

**OWNER COPY**

**CONTRACT**

**Bidder Certification  
In Compliance with Article 33E to the  
"Criminal Code of 1961"**

I Mike Figlio, do hereby certify that:

- I am the Regional Manager Pipe Services of the Michels Pipe Services; dba Michels Corp Position Firm and have authority to execute this certification on behalf of the firm
- This firm is not barred from bidding on this contract as a result of a violation of either Section 33E-3, Bid-rigging, or Section 33E-4, Bid Rotating, as set forth in Article 33E to the "Criminal Code of 1961."

Name of Firm Michels Corporation

Signature [Handwritten Signature]

Regional Manager

Date 07-29-19  
Corporate Seal (where appropriate)



On this 29th day of July, 2019, before me appeared (Name)

Mike Figlio to me personally known, who, being duly sworn, did execute the foregoing affidavit, and did state that he or she was properly authorized by (Name of Firm) Michels Corporation to execute the affidavit and did so as his or her free act and deed.

Notary Public Nicholas J. Frank Commission Expires 5-11-2020

Notary Seal



**OWNER COPY**

**CONTRACT**

**BIDDER CERTIFICATION  
REGARDING THE USE OF AMERICAN IRON AND STEEL PRODUCTS**

Mike Figlio, do hereby certify  
that: Name

1. I am Regional Manager Pipe Services (title) of the Michels Pipe Services; a division of Michels Corporation (company, partnership, etc.) and have authority to execute this certification on behalf of the firm.
2. This firm is aware that all iron and steel products used for this project must be produced in the United States per Section 436 (a) – (f) of the Consolidated Appropriations Act, 2014.
3. This firm is aware that the use of American iron and steel products applies to all projects for the construction, alteration, maintenance, or repair of publically owned treatment works (POTW) or public water systems.
4. This firm understands the term "iron and steel products" refers to the following products made primarily of iron or steel: lined or unlined pipes and fittings, manhole covers and other municipal castings, hydrants, tanks, flanges, pipe clamps and restraints, valves, structural steel, reinforced precast concrete, and construction materials.
5. I am aware that this requirement applies to all portions of the project that are subcontracted.

Name of Firm Michels Pipe Services; a division of Michels Corporation

Signature 

Title Regional Manager

Date 07-29-19

Corporate Seal (where appropriate)



**OWNER COPY**

**CONTRACT**

### Use of American Iron and Steel

Sec. 436. (a)(1) None of the funds made available by a State water pollution control revolving fund as authorized by title VI of the Federal Water Pollution Control Act (33 U.S.C. 1381 et seq.) or made available by a drinking water treatment revolving loan fund as authorized by section 1452 of the Safe Drinking Water Act (42 U.S.C. 300j-12) shall be used for a project for the construction, alteration, maintenance, or repair of a public water system or treatment works unless all of the iron and steel products used in the project are produced in the United States.

(2) In this section, the term 'iron and steel products' means the following products made primarily of iron or steel: lined or unlined pipes and fittings, manhole covers and other municipal castings, hydrants, tanks, flanges, pipe clamps and restraints, valves, structural steel, reinforced precast concrete, and construction materials.

(b) Subsection (a) shall not apply in any case or category of cases in which the Administrator of the Environmental Protection Agency (in this section referred to as the 'Administrator') finds that—

- (1) applying subsection (a) would be inconsistent with the public interest;
- (2) iron and steel products are not produced in the United States in sufficient and reasonably available quantities and of a satisfactory quality; or
- (3) inclusion of iron and steel products produced in the United States will increase the cost of the overall project by more than 25 percent.

(c) If the Administrator receives a request for a waiver under this section, the Administrator shall make available to the public on an informal basis a copy of the request and information available to the Administrator concerning the request, and shall allow for informal public input on the request for at least 15 days prior to making a finding based on the request. The Administrator shall make the request and accompanying information available by electronic means, including on the official public Internet Web site of the Environmental Protection Agency.

(d) This section shall be applied in a manner consistent with United States obligations under international agreements.

(e) The Administrator may retain up to 0.25 percent of the funds appropriated in this Act for the Clean and Drinking Water State Revolving Funds for carrying out the provisions described in subsection (a)(1) for management and oversight of the requirements of this section.

(f) This section does not apply with respect to a project if a State agency approves the engineering plans and specifications for the project, in that agency's capacity to approve such plans and specifications prior to a project requesting bids, prior to the date of the enactment of this Act.

**OWNER COPY**

**CONTRACT**

**United States Environmental Protection Agency  
Washington, DC  
20460**

**Certification Regarding Debarment, Suspension and Other Responsibility Matters**

The prospective participant to the best of its knowledge and belief that it and its principals:

- (a) Are not presently debarred, suspended, proposed for debarment, declared ineligible, or voluntarily excluded from covered transactions by any Federal department or agency;
- (b) Have not within a three year period preceding this proposal been convicted of or had a civil judgment rendered against them for commission of fraud or a criminal offense in connection with obtaining, attempting to obtain, or performing a public (Federal, State or local) transaction or contract under a public transaction; violation of Federal or State antitrust statutes or commission of embezzlement, theft, forgery, bribery, falsification or destruction of records, making false statements, or receiving stolen property.
- (c) Are not presently indicted for or otherwise criminally or civilly charged by a government entity (Federal, State or local) with commission of any of the offenses enumerated in paragraph (1) (b) of this certification; and
- (d) Have not within a three-year period preceding this application/proposal had one or more public transactions (Federal, State or local) terminated for cause or default.

I understand that a false statement on this certification may be grounds for rejection of this proposal or termination of the award. In addition, under 18 USC Sec. 1001, a false statement may result in fine of up to \$10,000 or imprisonment for up to 5 years, or both.

Mike Figlio Regional Manager Pipe Services  
(Typed Name & Title of Authorized Representative)

 7/27/19  
(Signature of Authorized Representative) (Date)

I am unable to certify the above statements. My explanation is attached.

**OWNER COPY**

**CONTRACT**

**FAIR EMPLOYMENT PRACTICES  
AFFIDAVIT OF COMPLIANCE**

NOTE: THIS AFFIDAVIT MUST BE EXECUTED AND SUBMITTED WITH THE SIGNED BID FORM. NO BIDS WILL BE ACCEPTED BY THE VILLAGE OF VILLA PARK UNLESS SAID AFFIDAVIT IS SUBMITTED CONCURRENTLY WITH THE BID.

Mike Figlio

being first duly sworn, deposes and says that he is the \_\_\_\_\_

Regional Manager Pipe Services of Michels Pipe Services; a division of Michels Corporation  
(Title or Office)

and that he has authority to make the following affidavit: that he has knowledge of the Village of Villa Park ordinance relating to Fair Employment Practices and knows and understands the contents thereof; that he certifies hereby that it is the policy of Michels Corporation

(Name of Company)

to recruit, hire, train, upgrade, promote and discipline its employees without regard to race, creed, color, religion, age, sex or physical or mental handicap; and that the company has and enforces policies which prohibit sexual harassment in the workplace.

SUBSCRIBED and sworn to before me this 29<sup>th</sup> day of July, 2019.

Nicholas J. Frank  
(Notary Public)

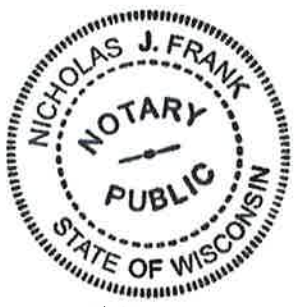

5-11-2020

**OWNER COPY**

**CONTRACT**

NON-COLLUSION AND CERTIFICATION STATEMENT

1. By submission of the Bid, each Bidder and, in the case of a joint Bid, each party to the joint Bid certifies as to his or her own organization, that in connection with the Bid:

a. The prices in the Bid have been arrived at independently, without consultation, communication, or agreement, for the purpose of restricting competition, as to any matter relating to the prices with any other bidder or with any competitor;

b. Unless otherwise required by law, the prices quoted in the Bid have not knowingly been directly or indirectly disclosed to any other bidder or to any competitor prior to Bid opening; and

c. No attempt has been made or will be made by the Bidder to induce any other person or firm to submit or withhold a Bid for the purpose of restricting competition. Also, each Bidder shall submit a certification regarding compliance with Article 33 E-11 of the Illinois Criminal Code of 1961 [720 ILCS 5/33 E-11]; and

2. Each person signing the Bid shall certify that (check one):

✓ He/she is the person in the Bidder's organization responsible for the decision as to the prices being bid and that he/she has not participated, and will not participate, in any action contrary to 1.a. through 1.c.; or

--- He/she is not the person in the Bidder's organization responsible for the decision as to the prices being bid but that he/she has been authorized to act as agent certifying that the persons determining the prices have not participated, and will not participate, in any action contrary to 1.a. through 1.c., and as their agent shall so certify. He/She shall also certify that he/she has not participated, and will not participate, in any action contrary to 1.a. through 1.c.

[Signature]
Signature of Authorized Representative

07/29/19
Date

Mike Figlio, Regional Manager Pipe Services
Typed Name and Title of Authorized Representative

Sworn and subscribed to before me this
29th day of July, 2019
Nicholas J. Frank

Notary Public or Other Officer
Authorized to Administer Oaths.
My Commission expires: 5-1-2020

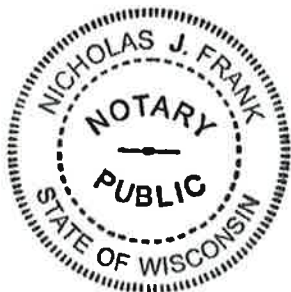

**OWNER COPY**

**CONTRACT**

**U.S. ENVIRONMENTAL PROTECTION AGENCY**

**CERTIFICATION OF NON-SEGREGATED FACILITIES**

(Applicable to federally assisted construction contracts and related subcontracts exceeding \$10,000 which are not exempt from the Equal Opportunity clause.)

The federally assisted construction contractor certifies that he does not maintain or provide for his employees any segregated facilities at any of his establishments, and that he does not permit his employees to perform their services at any location, under his control, where segregated facilities are maintained. The federally assisted construction contractor certifies further that he will not maintain or provide for his employees any segregated facilities at any of his establishments, and that he will not permit his employees to perform their services at any location, under his control, where segregated facilities are maintained. The federally assisted construction contractor agrees that a breach of this certification is a violation of the Equal Opportunity clause in this contract. As used in this certification, the term "segregated facilities" means any waiting rooms, work areas, rest rooms and other storage or dressing areas, parking lots, drinking fountains, recreation or entertainment areas, transportation, and housing facilities provided for employees which are segregated by explicit directive or are in fact segregated on the basis of race, creed, color, or national origin, because of habit, local custom or otherwise. The federally assisted construction contractor agrees that (except where he has obtained identical certifications from proposed subcontractors for specific time periods) he will obtain identical certifications from proposed subcontractors prior to the award of subcontracts exceeding \$10,000 which are not exempt from the provisions of the Equal Opportunity clause, and that he will retain such certification in his files.

  
\_\_\_\_\_  
Signature

07/29/19  
\_\_\_\_\_  
Date

Mike Figlio , Regional Manager Pipe Services  
\_\_\_\_\_  
Name and Title of Signer (Please type)

Michels Pipe Services; a division of Michels Corporation  
\_\_\_\_\_  
Firm Name

NOTE: The penalty for making false statements in offers is prescribed in 18 U.S.C. 1001.

**OWNER COPY**

**CONTRACT**

**Suggested Disadvantaged Business (DBE)  
Advertisement for Construction Contractors**

Notice to Disadvantaged Businesses

Michels Pipe Services;

A division of Michels Corp. 817 Main St. Brownsville, WI 53006. 920-583-3152, is  
(Name of Company) (Address of Company) (Telephone)

seeking disadvantaged businesses for the Village of Villa Park, IL  
(Name of Loan Recipient)

Project for subcontracting opportunities in the following areas: manhole Rehab Point repairs,  
grouting, Manhole Sealing

All disadvantaged businesses should contact, IN WRITING, (certified letter, return receipt requested),  
Michelle Nieves to discuss the subcontracting opportunities. All negotiations must  
(Company Contact Person)

be completed prior to bid opening 7-30-19.  
(Date of Bid Opening)

\*The advertisement must clearly state the method of evaluating the proposals or quotations, and the relative importance attached to each criterion. Bidders must uniformly and objectively evaluate the proposals submitted by disadvantaged business in response to the advertisement based upon the evaluation criteria stated in the advertisement. The evaluation criteria must not be restrictive or exclusionary.

**OWNER COPY**

**CONTRACT**

### Summary Report of Disadvantaged Business Enterprise Requirements for Contractors

- 1) Completed and signed certification from bidder(s), attesting that the bidder will award no sub-agreements, including the procurement of equipment, materials, supplies and services in the performance of this contract (may use IEPA DBE Form #1).

#### OR

- 2) "Certificate of publication, or adequate evidence of proof of publication, including an actual copy of the newspaper advertisement from a daily, regional publication. For advertisements placed in a construction project clearinghouse such as www.construction.com, a screenshot of the advertisement, link to website, and receipt is required for proof of advertising.

Dates of bidder advertisement: 7-13-19

Date of bid opening: 7-30-19

- 3) List of all disadvantaged business enterprises (DBE) and non-DBE's that submitted proposals to the bidder/prime contractor. Specify as DBE or non-DBE, type of DBE, and the other information listed below (DBE Form #4 may be used for this purpose).

Name of Company:

Name of Owners:

Address of Company:

E-mail Address of Company:

Telephone Number:

Date of Proposal:

\* \_\_\_\_\_ Business \_\_\_\_\_ Type of DBE:

Description of work to be performed

- 4) List of disadvantaged businesses that submitted proposals to the bidder but will not be utilized. Justification for non-utilization must be provided (may use IEPA DBE Form #1).
- 5) Completed and signed copies IEPA DBE Form #3 (Subcontractor Utilization Form). Only applies if using DBE subcontractors.
- 6) Completed and signed certification from bidder(s) attesting that the bidder has no dominating or conflict of interest with the disadvantaged business to be utilized (IEPA DBE Form #1). Only applies if using DBE subcontractors.
- 7) In instances where the bidder(s) does not receive any proposals from disadvantaged businesses prior to bid opening, the bidder(s) must provide a written certification attesting that no proposals were received (IEPA DBE Form #1).
- 8) **Note:** DBE Form #2 is **not** included in this packet. It is for consultants/engineers to report DBE activity. It is for consultants/engineers to report DBE activity. This form may be found in IEPA's DBE Guidance Manual which is available on the Agency's website or mailed upon request by calling 217-782-2027.

**OWNER COPY**

**CONTRACT**



# Illinois Environmental Protection Agency

1021 North Grand Avenue East • P.O. Box 19276 • Springfield • Illinois • 62794-9276 • (217) 782-3397

## Disadvantaged Business Enterprise (DBE) Program DBE Form #1 - Contractor Certification

(To be completed by all Prime Contractors)

Please check the appropriate boxes that apply and complete the information on the bottom of the form.

This firm will award no subcontracts (including in the procurement of equipment, supplies, or services), in the performance of this contract.

This firm advertised for DBE subcontractors according to the good faith efforts outlined in the IEPA DBE Guidance Document.

This firm received proposals from DBE(s) that will not be utilized. A list of the DBEs not hired, along with their address, phone number, and reason(s) for non-utilization, is below.

Name of DBE	Address	Phone	Reason for Non-Utilization
Archon Construction, Inc.	563 S. Route 53 Addison, IL 60101	630-495-0015	Not Economically Feasible
Smith Maintenance Co.	2221 W. Walnut St. Chicago, IL 60612	312-733-4301	Not Economically Feasible

This firm did not receive any inquiries from DBEs.

I certify that the above is true. I further certify that this firm and its partners, directors, and officers do not possess a controlling interest in ownership or conflict of interest or any other authority to control the DBE to be used during the performance of the contracts.

Signature:   
Date: 7/29/19

Name: Mike Figlio  
Title: Regional Manager  
Company: Michels Ripa Services

**OWNER COPY**

**CONTRACT**



# Illinois Environmental Protection Agency

1021 North Grand Avenue East • P.O. Box 19276 • Springfield • Illinois • 62794-9276 • (217) 782-3397

## Disadvantaged Business Enterprise (DBE) Program DBE Form #3 - Subcontractor Utilization

(Only complete this form if DBE subcontractors or sub-consultants will be working on the project)

This form is intended to capture the DBE subcontractor's description of work to be performed and the price of the work submitted to the prime contractor. All subcontractors must complete this form, and it must be included in the prime contractor's bid package.

Subcontractor Name <i>N/A</i>		Project Name <i>N/A</i>	
Contact Person's Name & Title			
Address			
Telephone		Email	
DBE Certified By		Select One: <input type="radio"/> MBE <input type="radio"/> WBE <input type="radio"/> SBE <input type="radio"/> DBE	
Prime Contractor Name			
Type of Work to be Performed			Cost Estimate of Work

I certify under penalty of perjury that the forgoing statements are true and correct. Signing this form does not signify a commitment to using the subcontractors above. I am aware that in the event of a replacement of a subcontractor, I will adhere to the replacement requirements set forth in 40 C.F.R. Part 33 Section 33.302(c).

Prime Contractor Signature		Printed Name	
Date		Title	
Subcontractor Signature		Printed Name	
Date		Title	

**OWNER COPY**

**CONTRACT**



# Illinois Environmental Protection Agency

1021 North Grand Avenue East • P.O. Box 19276 • Springfield • Illinois • 62794-9276 • (217) 782-3397

## Disadvantaged Business Enterprise (DBE) Program DBE Form #4 - Bidders List

(Only complete this form if subcontractors will be working on the project)

Company Name & Contact Person	Address	Phone Number with area code	Email	Proposed Work (supplies, paint, etc)	DBE Status
Suburban General Construction, Inc.	1019 E. 31st Street LaGrange Park, IL 60526	708-354-0544	Subgenle@yahoo.com	Point repairs, covers, Frames, etc.	<input type="radio"/> MBE <input type="radio"/> WBE <input type="radio"/> SBE <input type="radio"/> DBE <input checked="" type="radio"/> Not a DBE <input type="checkbox"/> Check if hired
Musson Bros. INC	1522 Pearl Street Waukesha, WI 53186	262-790-5660	Shyschene@mussonbrothers.com	T-Liners	<input type="radio"/> MBE <input type="radio"/> WBE <input type="radio"/> SBE <input type="radio"/> DBE <input checked="" type="radio"/> Not a DBE <input type="checkbox"/> Check if hired
Construction Video media	111 East Newberry Romeo, MI 48065	800-346-3342	dspenglere@constructionvideomedia.com	Above ground video	<input type="radio"/> MBE <input type="radio"/> WBE <input type="radio"/> SBE <input type="radio"/> DBE <input checked="" type="radio"/> Not a DBE <input type="checkbox"/> Check if hired
Cully Contracting	5 Industrial Pkwy Winchester, IN 47394	765-584-8509	jacobs.hortemidas@compair.com	Manhole Rehab	<input type="radio"/> MBE <input type="radio"/> WBE <input type="radio"/> SBE <input type="radio"/> DBE <input checked="" type="radio"/> Not a DBE <input type="checkbox"/> Check if hired

**OWNER COPY**

**CONTRACT**



# Illinois Environmental Protection Agency

1021 North Grand Avenue East • P.O. Box 19276 • Springfield • Illinois • 62794-9276 • (217) 782-3397

## Disadvantaged Business Enterprise (DBE) Program DBE Form #4 - Bidders List

(Only complete this form if subcontractors will be working on the project)

Company Name & Contact Person	Address	Phone Number with area code	Email	Proposed Work (supplies, paint, etc)	DBE Status
Sheridan Plumbing and Sewer	6754 W. 74th St. Bedford Park, IL 60638	708-475-7100	acimarro@sparks.com	Point Repairs	<input type="radio"/> MBE <input type="radio"/> WBE <input type="radio"/> SBE <input type="radio"/> DBE <input checked="" type="radio"/> Not a DBE <input type="checkbox"/> Check if hired
Archon Construction	563 S. Route 53	630-495-0015	jbartone@archoninc.com	Point Repairs	<input type="radio"/> MBE <input checked="" type="radio"/> WBE <input type="radio"/> SBE <input type="radio"/> DBE <input type="radio"/> Not a DBE <input type="checkbox"/> Check if hired
Smith Maintenance Company	2721 W. Walnut Chicago, IL 60612	312-753-4301	john@smithmaint.com	Traffic Control	<input checked="" type="radio"/> MBE <input type="radio"/> WBE <input type="radio"/> SBE <input type="radio"/> DBE <input type="radio"/> Not a DBE <input type="checkbox"/> Check if hired
					<input type="radio"/> MBE <input type="radio"/> WBE <input type="radio"/> SBE <input type="radio"/> DBE <input type="radio"/> Not a DBE <input type="checkbox"/> Check if hired

**OWNER COPY**

**CONTRACT**

**VILLAGE OF VILLA PARK**

**PROJECT: Village of Villa Park, 2019 Sewer Rehabilitation Program**

**BID OPENING: Tuesday, July 30, 2019, 11:00 A.M.**

**ADDENDUM NO. 1**

**Instructions: Please sign and date this receipt as acknowledgement of ADDENDUM NO.1 for the above-referenced project and submit it with your bid.**

**Failure to acknowledge receipt of ADDENDUM NO.1 may result in Contractor's BID being considered non-compliant.**

**Bidder shall also state on the OUTSIDE of the bid submittal envelope that he or she is in receipt of addendum #1 or your bid may not be opened**

**Signature:**  \_\_\_\_\_

**Name:** Mike Figlio

**Company:** Michels Pipe Services; a division of Michels Corporation

**Position:** Regional Manager Pipe Services

**Date:** 07-29-19

*This page intentionally left blank.*

**NOTICE OF REQUIREMENT  
FOR AFFIRMATIVE ACTION TO ENSURE EQUAL EMPLOYMENT OPPORTUNITY  
(EXECUTIVE ORDER 11246)**

1. The Offeror's or Bidder's attention is called to the "Equal Opportunity Clause" and the Standard Federal Equal Employment Opportunity Construction Contract Specifications" set forth herein.
2. The goals and timetables for minority and female participation, expressed in percentage terms for the Contractor's aggregate workforce in each trade on all construction work in the covered area, are as follows:

Timetables	Goals for minority participation for each trade	Goals for female participation in each trade
	Insert goals for* each year 19.6%	Insert goals for* each year 6.9%

These goals are applicable to all of the Contractor's construction work (whether or not it is Federal or federally assisted) performed in the covered area.

The Contractor's compliance with the Executive Order and the regulations in 41 CFR Part 60-4 shall be based on its implementation of the Equal Opportunity Clause, specific affirmative action obligations required by the specifications set forth in 41 CFR 60-4.3(a), and its efforts to meet the goals established for the geographical area where the contract resulting from this solicitation is to be performed. The hours of minority and female employment and training must be substantially uniform throughout the length of the contract, and in each trade, and the contractor shall make a good faith effort to employ minorities and women evenly on each of its projects. The transfer of minority or female employees or trainees from Contractor to Contractor or from project to project for the sole purpose of meeting the Contractor's goals shall be a violation of the contract, the Executive Order and the regulations in 41 CFR 60-4. Compliance with the goals will be measured against the total work hours performed.

3. The Contractor shall provide written notification to the Director of the Office of Federal Contract Compliance Programs within 10 working days of award of any construction subcontract in excess of \$10,000 at any tier for construction work under the contract resulting from this solicitation. The notification shall list the name, address and telephone number of the subcontractor; employer identification number; estimated dollar amount of the subcontract; estimated starting and completion dates of the subcontract; and the geographical area in which the contract is to be performed.
4. As used in this Notice, and in the contract resulting from this solicitation, the "covered area" is Village of Villa Park.

\*Goals and timetables published from time to time by the Director, Office of Federal Contract Compliance Programs (OFCCP)

\*\*Insert description of the geographical areas where the contract is to be performed giving the state, county and city, if any.

***This page intentionally left blank.***

CONSTRUCTION CONTRACTORS AFFIRMATIVE ACTION REQUIREMENTS  
GOALS FOR MINORITY PARTICIPATION

(As published in the Friday, October 3, 1980 Federal Register)

FEMALE PARTICIPATION= 6.9% STATEWIDE

<u>County</u>	<u>Percent</u>	<u>County</u>	<u>Percent</u>	<u>County</u>	<u>Percent</u>
Adams	3.1	Jasper	11.4	Randolph	11.4
Alexander	11.4	Jefferson	11.4	Richland	11.4
Bond	11.4	Jersey	11.4	Rock Island	4.6
Boone	6.3	Jo Davis	0.5	Saline	3.5
Brown	3.1	Johnson	11.4	Sangamon	4.5
Bureau	18.4	Kane	19.6	Schuyler	3.3
Calhoun	11.4	Kankakee	9.1	Scott	4
Carroll	3.4	Kendall	18.4	Shelby	4
Cass	4	Knox	3.3	Stark	3.3
Champaign	7.8	Lake	19.6	St. Clair	14.7
Christian	4	La Salle	18.4	Stephenson	4.6
Clark	2.5	Lawrence	3.5	Tazwell	4.4
Clay	11.4	Lee	4.6	Union	11.4
Clinton	14.7	Livingston	18.4	Vermilion	4.8
Coles	4.8	Logan	4	Wabash	3.5
Cook	19.6	Macon	7.6	Warren	3.3
Crawford	2.5	Macoupin	11.4	Washington	11.4
Cumberland	4.8	Madison	14.7	Wayne	11.4
De Kalb	18.4	Marion	11.4	White	3.5
De Witt	4	Marshall	3.3	Whiteside	3.4
Douglas	4.8	Mason	3.3	Will	20.9
Du Page	19.6	Massac	5.2	Williamson	11.4
Edgar	4.8	McDonough	3.3	Winnebago	6.3
Edwards	3.5	McHenry	19.6	Woodford	4.4
Effingham	11.4	McLean	2.5		
Fayette	11.4	Menard	4.5		
Ford	4.8	Mercer	3.4		
Franklin	11.4	Monroe	14.7		
Fulton	3.3	Montgomery	11.4		
Gallatin	3.5	Morgan	4		
Greene	11.4	Moultrie	4		
Grundy	18.4	Ogle	4.6		
Hamilton	3.5	Peoria	4.4		
Hancock	3.4	Perry	11.4		
Hardin	5.2	Piatt	4.8		
Henderson	3.4	Pike	3.1		
Henry	4.6	Pope	5.2		
Iroquois	18.4	Pulaski	11.4		
Jackson	11.4	Putnam	18.4		

*This page intentionally left blank.*

**41 CFR 60****60-4.1 Scope and Application.**

This part applies to all contractors and subcontractors that hold any Federal or federally assisted construction contract in excess of \$10,000. The regulations in this part are applicable to all of a construction contractor's or subcontractor's construction employees who are engaged in on site construction including those construction employees who work on a non-Federal or nonfederally assisted construction site. This part also establishes procedures, which all Federal contracting officers and all applicants, as applicable, shall follow in soliciting for and awarding Federal or federally assisted construction contracts. Procedures also are established which administering agencies shall follow in making any grant, contract, loan, insurance, or guarantee involving federally assisted construction which is not exempt from the requirements of Executive Order 11246, as amended. In addition, this part applies to construction work performed by construction contractors and subcontractors for Federal nonconstruction contractors and subcontractors if the construction work is necessary in whole or in part to the performance of a nonconstruction contract or subcontract.

[43 FR 49254, OCT. 20, 1978; 43 FR 51404, NOV. 3, 1978]

**60-4.2 Solicitations.**

(a) All Federal contracting officers and all applicants shall include the notice set forth in paragraph (d) of this section and the Standard Federal Equal Employment Opportunity Construction Contract Specifications set forth in 60-4.3 of this part in all solicitations for offers and bids on all Federal and federally assisted construction contracts or subcontracts to be performed in geographical areas designated by the Director pursuant to 60-4.6 of the part. Administering agencies shall require the inclusion of the notice set forth in paragraph (d) of this section and the specifications set forth in 60-4.3 of this part as a condition of any grant, contract, subcontract, loan, insurance or guarantee involving federally assisted construction covered by this Part 60-4.

(b) All nonconstruction contractors covered by Executive Order 11246 and the implementing regulations shall include the notice in paragraph (d) of this section in all construction agreements, which are necessary in whole or in part to the performance of the covered nonconstruction contract.

(c) Contracting officers, applicants and nonconstruction contractors shall give written notice to the Director within 10 working days of award of a contract subject to these provisions. The notification shall include the name, address and telephone number of the contractor; employer identification number; dollar amount of the contract; estimated starting and completion dates of the contract; the contract number; and geographical area in which the contract is to be performed.

(d) The following notice shall be included in, and shall be a part of, all solicitations for offers and bids on all Federal and federally assisted construction contracts or subcontracts in excess of \$10,000 to be performed in geographical areas designated by the Director pursuant to 60-4.6 of this part (see 41 CFR 60-4.2(a)):

**Notice of Requirement for Affirmative Action To Ensure Equal Employment Opportunity (Executive Order 11246)**

1. The Offeror or Bidder's attention is called to the "Equal Opportunity Clause" and the "Standard Federal Equal Employment Specifications" set forth herein.
2. The goals and timetables for minority and female participation, expressed in percentage terms for the Contractor's aggregate workforce in each trade on all construction work in the covered area, are as follows:

Time-tables	Goals for minority participation for each trade	Goals for female participation in each trade
	19.6%	6.9%

These goals are applicable to all the Contractor's construction work (whether or not it is Federal or federally assisted) performed in the covered area. If the contractor performs construction work in a geographical area located outside of the covered area, it shall apply the goals established for such geographical area where the work is actually performed. With regard to this second area, the contractor also is subject to the goals for both its federally involved and nonfederally involved construction.

The Contractor's compliance with the Executive Order and the regulations in 41 CFR Part 60-4 shall be based on its implementation of the Equal Opportunity Clause, specific affirmative action obligations required by the specifications set forth in 41 CFR 60-4.3(a), and its efforts to meet the goals. The hours of minority and female employment and training must be substantially uniform throughout the length of the contract, and in each trade, and the contractor shall make a good faith effort to employ minorities and women evenly on each of its projects. The transfer of minority or female employees or trainees from Contractor to Contractor or from project to project for the sole purpose of meeting the Contractor's goals shall be a violation of the contract, the Executive Order and the regulations in 41 CFR Part 60-4. Compliance with the goals will be measured against the total work hours performed.

3. The Contractor shall provide written notification to the Director of the Office of Federal Contract Compliance Programs within 10 working days of award of any construction subcontract in excess of \$10,000 at any tier for construction work under the contract resulting from this solicitation. The notification shall list the name, address and telephone number of the subcontractor; employer identification number of the subcontractor; estimated dollar amount of the subcontract; estimated starting and completion dates of the subcontract; and the geographical area in which the subcontract is to be performed.

4. As used in this Notice, and in the contract resulting from this solicitation, the "covered area" is (insert description of the geographical areas where the contract is to be performed giving the state, county and city, if any).

[43 FR 49254, OCT. 20, 1978; 43 FR 51401, NOV. 3, 1978, AS AMENDED AT 45 FR 65977, OCT. 3, 1980]

**60-4.3 Equal Opportunity Clauses.**

(a) The equal opportunity clause published at 41 CFR 60-1.4(a) of this chapter is required to be included in, and is part of, all nonexempt Federal contracts and subcontracts, including construction contracts and subcontracts. The equal opportunity clause published at 41 CFR 60-1.4(b) is required to be included in, and is a part of, all nonexempt federally assisted construction contracts and subcontracts. In addition to the clauses described above, all Federal contracting officers, all applicants and all nonconstruction contractors, as applicable, shall include the specifications set forth in this section in all Federal and federally assisted construction contracts in excess of \$10,000 to be performed in geographical areas designated by the Director pursuant to 60-4.6 of this part and in construction subcontracts in excess of \$10,000 necessary in whole or in part to the performance of nonconstruction Federal contracts and subcontracts covered under the Executive order.

**Standard Federal Equal Employment Opportunity Construction Contract Specifications (Executive Order 11246)**

1. As used in these specifications:

a. "Covered area," means the geographical area described in the solicitation from which this contract resulted:

b. "Director" means Director, Office of Federal Contract Compliance Programs, United States Department of Labor, or any person to whom the Director delegates authority;

c. "Employer identification number" means the Federal Social Security number used on the Employer's Quarterly Federal Tax Return, U.S. Treasury Department Form 941.

d. "Minority" includes:

(i) Black (all persons having origins in any of the Black African racial groups not of Hispanic origin);

(ii) Hispanic (all persons of Mexican, Puerto Rican, Cuban, Central or South American or other Spanish Culture or origin, regardless of race);

(iii) Asian and Pacific Islander (all persons having origins in any of the original peoples of the Far East, Southeast Asia, the Indian Subcontinent, or the Pacific Islands); and

(iv) American Indian or Alaskan Native (all persons having origins in any of the original peoples of North America and maintaining identifiable tribal affiliations through membership and participation or community identification).

2. Whenever the Contractor, or any Subcontractor at any tier, subcontracts a portion of the work involving any construction trade, it shall physically include in each subcontract in excess of \$10,000 the provisions of these specifications and the Notice which contains the applicable goals for minority and female participation and which is set forth in the solicitations from which this contract resulted.

3. If the Contractor is participating (pursuant to 41 CFR 60-4.5) in a Hometown Plan approved by the U.S. Department of Labor in the covered area either individually or through an association, its affirmative

action obligations on all work in the Plan area (including goals and timetables) shall be in accordance with that Plan for those trades which have unions participating in the Plan. Contractors must be able to demonstrate their participation in and compliance with the provisions of any such Hometown Plan. Each Contractor or Subcontractor participating in an approved Plan is individually required to comply with its obligations under the EEO clause, and to make a good faith effort to achieve each goal under the Plan in each trade in which it has employees. The overall good faith performance by other Contractors or Subcontractors toward a goal in an approved Plan does not excuse any covered Contractor or Subcontractor's failure to take good faith efforts to achieve the Plan goals and timetables.

4. The Contractor shall implement the specific affirmative action standards provided in paragraphs 7 a through p of these specifications. The goals set forth in the solicitation from which this contract resulted are expressed as percentages of the total hours of employment and training of minority and female utilization the Contractor should reasonably be able to achieve in each construction trade in which it has employees in the covered area. Covered Construction contractors performing construction work in geographical areas where they do not have a Federal or federally assisted construction contract shall apply the minority and female goals established for the geographical area where the work is being performed. Goals are published periodically in the Federal Register in notice form, and such notices may be obtained from any Office of Federal Contract Compliance Programs office or from Federal procurement contracting officers. The Contractor is expected to make substantially uniform progress in meeting its goals in each craft during the period specified.

5. Neither the provisions of any collective bargaining agreement, nor the failure by a union with whom the Contractor has a collective bargaining agreement, to refer either minorities or women shall excuse the Contractor's obligations under these specifications, Executive Order 11246, nor the regulations promulgated pursuant thereto.

6. In order for the nonworking training hours of apprentices and trainees to be counted in meeting the goals, the Contractor must employ such apprentices and trainees during the training period, and the Contractor must have made a commitment to employ the apprentices and trainees at the completion of their training, subject to the availability of employment opportunities. Trainees must be trained pursuant to training programs approved by the U.S. Department of Labor.

7. The Contractor shall take specific affirmative actions to ensure equal employment opportunity. The evaluation of the Contractor's compliance with these specifications shall be based upon its effort to achieve maximum results from its actions. The Contractor shall document these efforts fully, and shall implement affirmative action steps at least as extensive as the following:

a. Ensure and maintain a working environment free of harassment, intimidation, and coercion at all sites, and in all facilities at which the Contractor's employees are assigned to work. The Contractor, where possible, will assign two or more women to each construction project. The Contractor shall specifically ensure that all foremen, superintendents, and other on-site supervisory personnel are aware of and carry out the Contractor's obligation to maintain such a working environment, with specific attention to minority or female individuals working at such sites or in such facilities.

b. Establish and maintain a current list of minority and female recruitment sources, provide written notification to minority and female recruitment sources and to community organizations when the Contractor or its unions have employment opportunities available, and maintain a record of the organizations'

responses.

c. Maintain a current file of the names, addresses and telephone numbers of each minority and female off-the-street applicant and minority or female referral from a union, a recruitment source or community organization and of what action was taken with respect to each such individual. If such individual was sent to the union hiring hall for referral and was not referred back to the Contractor by the union or, if referred, not employed by the Contractor, this shall be documented in the file with the reason therefore; along with whatever additional actions the Contractor may have taken.

d. Provide immediate written notification to the Director when the union or unions with which the Contractor has a collective bargaining agreement has not referred to the Contractor a minority person or woman sent by the Contractor, or when the Contractor has other information that the union referral process has impeded the Contractor's efforts to meet its obligations.

e. Develop on-the-job training opportunities and/or participate in training programs for the area which expressly include minorities and women, including upgrading programs and apprenticeship and trainee programs relevant to the Contractor's employment needs, especially those programs funded or approved by the Department of Labor. The Contractor shall provide notice of these programs to the sources compiled under 7b above.

f. Disseminate the Contractor's EEO policy by providing notice of the policy to unions and training programs and requesting their cooperation in assisting the Contractor in meeting its EEO obligations; by including it in any policy manual and collective bargaining agreement; by publicizing it in the company newspaper, annual report, etc.; by specific review of the policy with all management personnel and with all minority and female employees at least once a year, and by posting the company EEO policy on bulletin boards accessible to all employees at each location where construction work is performed.

g. Review, at least annually, the company's EEO policy and affirmative action obligations under these specifications with all employees having any responsibility for hiring, assignment, layoff, termination or other employment decisions including specific review of these items with onsite supervisory personnel such as Superintendents, General Foremen, etc., prior to the initiation of construction work at any job site. A written record shall be made and maintained identifying the time and place of these meetings, persons attending, subject matter discussed, and disposition of the subject matter.

h. Disseminate the Contractor's EEO policy externally by including it in any advertising in the news media, specifically including minority and female news media, and providing written notification to and discussing the Contractor's EEO policy with other Contractors and Subcontractors with whom the Contractor does or anticipates doing business.

i. Direct its recruitment efforts, both oral and written, to minority, female and community organizations, to schools with minority and female students and to minority and female recruitment and training organizations serving the Contractor's recruitment area and employment needs. Not later than one month prior to the date for the acceptance of applications for apprenticeship or other training by any recruitment source, the Contractor shall send written notification to organizations such as the above, describing the openings, screening procedures, and tests to be used in the selection process.

j. Encourage present minority and female employees to recruit other minority persons and women

and, where reasonable, provide after school, summer and vacation employment to minority and female youth both on the site and in other areas of a Contractor's work force.

**k.** Validate all tests and other selection requirements where there is an obligation to do so under 41 CFR Part 60-3.

**l.** Conduct, at least annually, an inventory and evaluation at least of all minority and female personnel for promotional opportunities and encourage these employees to seek or to prepare for, through appropriate training, etc., such opportunities.

**m.** Ensure that seniority practices, job classifications, work assignments and other personnel practices, do not have a discriminatory effect by continually monitoring all personnel and employment related activities to ensure that the EEO policy and the Contractor's obligations under these specifications are being carried out.

**n.** Ensure that all facilities and company activities are non-segregated except that separate or single-user toilet and necessary changing facilities shall be provided to assure privacy between the sexes.

**o.** Document and maintain a record of all solicitations of offers for subcontracts from minority and female construction contractors and suppliers, including circulation of solicitations to minority and female contractor associations and other business associations.

**p.** Conduct a review, at least annually, of all supervisors' adherence to and performance under the Contractor's EEO policies and affirmative action obligations.

**8.** Contractors are encouraged to participate in voluntary associations, which assist in fulfilling one or more of their affirmative action obligations (7a through p). The efforts of a contractor association, joint contractor-union, contractor-community, or other similar group of which the contractor is a member and participant, may be asserted as fulfilling any one or more of its obligations under 7a through p of these Specifications provided that the contractor actively participates in the group, makes every effort to assure that the group has a positive impact on the employment of minorities and women in the industry, ensures that the concrete benefits of the program are reflected in the Contractor's minority and female workforce participation, makes a good faith effort to meet its individual goals and timetables, and can provide access to documentation which demonstrates the effectiveness of actions taken on behalf of the Contractor. The obligation to comply, however, is the Contractor's and failure of such a group to fulfill an obligation shall not be a defense for the Contractor's noncompliance.

**9.** A single goal for minorities and a separate single goal for women have been established. The Contractor, however, is required to provide equal employment opportunity and to take affirmative action for all minority groups, both male and female, and all women, both minority and non-minority. Consequently, the Contractor may be in violation of the Executive Order if a particular group is employed in a substantially disparate manner (for example, even though the Contractor has achieved its goals for women generally, the Contractor may be in violation of the Executive Order if a specific minority group of women is underutilized).

**10.** The Contractor shall not use the goals and timetables or affirmative action standards to discriminate against any person because of race, color, religion, sex, or national origin.

11. The Contractor shall not enter into any Subcontract with any person or firm debarred from Government contracts pursuant to Executive Order 11246.

12. The Contractor shall carry out such sanctions and penalties for violation of these specifications and of the Equal Opportunity Clause, including suspension, termination and cancellation of existing subcontracts as may be imposed or ordered pursuant to Executive Order 11246, as amended, and its implementing regulations, by the Office of Federal Contract Compliance Programs. Any Contractor who fails to carry out such sanctions and penalties shall be in violation of these specifications and Executive Order 11246, as amended.

13. The Contractor, in fulfilling its obligations under these specifications, shall implement specific affirmative action steps, at least as extensive as those standards prescribed in paragraph 7 of these specifications, so as to achieve maximum results from its efforts to ensure equal employment opportunity. If the Contractor fails to comply with the requirements of the Executive Order, the implementing regulations, or these specifications, the Director shall proceed in accordance with 41 CFR 60-4.8.

14. The Contractor shall designate a responsible official to monitor all employment related activity to ensure that the company EEO policy is being carried out, to submit reports relating to the provisions hereof as may be required by the Government and to keep records. Records shall at least include for each employee the name, address, telephone numbers, construction trade, union affiliation if any, employee identification number when assigned, social security number, race, sex, status (e.g., mechanic, apprentice trainee, helper, or laborer), dates of changes in status, hours worked per week in the indicated trade, rate of pay, and locations at which the work was performed. Records shall be maintained in an easily understandable and retrievable form; however, to the degree that existing records satisfy this requirement, contractors shall not be required to maintain separate records.

15. Nothing herein provided shall be construed as a limitation upon the application of other laws, which establish different standards of compliance or upon the application of requirements for the hiring of local or other area residents (e.g., those under the Public Works Employment Act of 1977 and the Community Development Block Grant Program).

(b) The notice set forth in 41 CFR 60-4.2 and the specifications set forth in 41 CFR 60-4.3 replace the New Form for Federal Equal Employment Opportunity Bid Conditions for Federal and Federally Assisted Construction published at 41 FR 32482 and commonly known as the Model Federal EEO Bid Conditions, and the New Form shall not be used after the regulations in 41 CFR Part 60-4 become effective.

[43 FR 49254, OCT. 20, 1978; 43 FR 51401, NOV. 3, 1978, AS AMENDED AT 45 FR 65978, OCT. 3, 1980]

#### **60-4.4 Affirmative Action Requirements.**

(a) To implement the affirmative action requirements of Executive Order 11246 in the construction industry, the Office of Federal Contract Compliance Programs previously has approved affirmative action programs commonly referred to as "Hometown Plans," has promulgated affirmative action plans referred to as "Imposed Plans" and has approved "Special Bid Conditions" for high impact projects constructed in areas not covered by a Hometown or an Imposed Plan. All solicitations for construction contracts made after the effective date of the regulations in this part shall include the notice specified in 60-4.2 of this part and the

specifications in 60-4.3 of this part in lieu of the Hometown and Imposed Plans including the Philadelphia Plan and Special Bid Conditions. Until the Director has issued an order pursuant to 60-4.6 of this part establishing goals and timetables for minorities in the appropriate geographical areas or for a project covered by Special Bid Conditions, the goals and timetables for minorities to be inserted in the Notice required by 41 CFR 60-4.2 shall be the goals and timetables contained in the Hometown Plan, Imposed Plan or Special Bid Conditions presently covering the respective geographical area or project involved.

**(b)** Signatories to a Hometown Plan (including heavy highway affirmative action plans) shall have 45 days from the effective date of the regulations in this part to submit under such a Plan (for the director's approval) goals and timetables for women and to include female representation on the Hometown Plan Administrative Committee. Such goals for female representation shall be at least as high as the goals established for female representation in the notice issued pursuant to 41 CFR 60-4.6. Failure of the signatories, within the 45-day period, to include female representation and to submit goals for women or a new plan, as appropriate, shall result in an automatic termination of the Office of Federal Contract Compliance Programs approval of the Hometown Plan. At any time the Office of Federal Contract Compliance Programs terminates or withdraws its approval of a Hometown Plan, or when the plan expires and another plan is not approved, the contractor's signatory to the plan shall be covered automatically by the specifications set forth in 60-4.3 of this part and by the goals and timetables established for that geographical area pursuant to 60-4.6 of this part.

#### **60-4.5 Hometown Plans**

**(a)** A contractor participating, either individually or through an association, in an approved Hometown Plan (including heavy highway affirmative action plans) shall comply with its affirmative action obligations under Executive Order 11246 by complying with its obligations under the plan: *Provided*, That each contractor or subcontractor participating in an approved plan is individually required to comply with the equal opportunity clause set forth in 41 CFR 60-1.4; to make a good faith effort to achieve the goals for each trade participating in the plan in which it has employees; and that the overall good performance by other contractors or subcontractors toward a goal in an approved plan does not excuse any covered contractor's or subcontractor's failure to take good faith efforts to achieve the plan's goals and timetables. If a contractor is not participating in an approved Hometown Plan it shall comply with the specifications set forth in 60- 4.3 of this part and with the goals and timetables for the appropriate area as listed in the notice required by 41 CFR 60-4.2 with regard to that trade. For the purposes of this part 60-4, a contractor is not participating in a Hometown Plan for a particular trade if it:

**(1)** Ceases to be signatory to a Hometown Plan covering that trade;

**(2)** Is signatory to a Hometown Plan for that trade but is not party to a collective bargaining agreement for that trade;

**(3)** Is signatory to a Hometown Plan for that trade but is party to a collective bargaining agreement with labor organizations, which are not or cease to be signatories to the same Hometown Plan for that trade;

**(4)** Is signatory to a Hometown Plan for that trade but is party to a collective bargaining agreement with a labor organization for that trade but the two have not jointly executed a specific commitment to minority and female goals and timetables and incorporated the commitment in the Hometown Plan for that trade;

(5) Is participating in a Hometown Plan for that trade which is no longer acceptable to the Office of Federal Contract Compliance Programs;

(6) Is signatory to a Hometown Plan for that trade but is party to a collective bargaining agreement with a labor organization for that trade and the labor organization and the contractor have failed to make a good faith effort to comply with their obligations under the Hometown Plan for that trade.

(b) Contractors participating in Hometown Plans must be able to demonstrate their participation and document their compliance with the provision of the Hometown Plan.

[43 FR 49254, OCT. 20, 1978; 43 FR 51401, NOV. 3, 1978]

#### **60-4.6 Goals and Timetables.**

The Director, from time to time, shall issue goals and timetables for minority and female utilization, which shall be based on appropriate workforce, demographic, or other relevant data and which shall cover construction projects or construction contracts performed in specific geographical areas. The goals, which shall be applicable to each construction trade in a covered contractor's or subcontractor's entire workforce which is working in the area covered by the goals and timetables, shall be published as notices in the Federal Register, and shall be inserted by the contracting officers and applicants, as applicable, in the Notice required by 41 CFR 60-4.2. Covered construction contractors performing construction work in geographical areas where they do not have a Federal or federally assisted construction contract shall apply the minority and female goals established for the geographical area where the work is being performed.

[45 FR 65978, OCT. 3, 1980]

#### **60-4.7 Effect on Other Regulations.**

The regulations in this part are in addition to the regulations contained in this chapter, which apply to construction contractors and subcontractors generally. See particularly, 41 CFR 60-1.4 (a), (b), (c), (d), and (e); 60-1.5; 60-1.7; 60-1.8; 60-1.26; 60-1.29; 60-1.30; 60-1.32; 60-1.41; 60-1.42; 60-1.43; and 41 CFR Part 60-3; Part 60-20; Part 60-30; Part 60-40; and Part 60-50.

#### **60-4.8 Show Cause Notice.**

If an investigation or compliance review reveals that a construction contractor or subcontractor has violated the Executive order, any contract clause, specifications or the regulations in this chapter and if administrative enforcement is contemplated, the Director shall issue to the contractor or subcontractor a notice to show cause which shall contain the items specified in paragraphs (i) through (iv) of 41 CFR 60-2.2(c)(1). If the contractor does not show good cause within 30 days, or in the alternative, fails to enter an acceptable conciliation agreement which includes where appropriate, make up goals and timetables, back pay, and seniority relief for affected class members, the OFCCP shall follow the procedure in 41 CFR 60-1.26(b): *Provided*, That where a conciliation agreement has been violated, no show cause notice is required prior to the initiation of enforcement proceedings.

[43 FR 49254, OCT. 20, 1978; 43 FR 51401, NOV. 3, 1978]

**60-4.9 Incorporation by Operation of the Order.**

By operation of the order, the equal opportunity clause contained in 60-1.4, the Notice of Requirement for Affirmative Action to Ensure Equal Employment Opportunity (Executive Order 11246) contained in 60-4.2, and the Standard Federal Equal Employment Opportunity Construction Contract Specifications (Executive Order 11246) contained in 60-4.3 shall be deemed to be a part of every solicitation or of every contract and subcontract, as appropriate, required by the order and the regulations in this chapter to include such clauses whether or not they are physically incorporated in such solicitation or contract and whether or not the contract is written.

**NOTICE TO LABOR UNIONS OR OTHER ORGANIZATIONS OF WORKERS**

**NONDISCRIMINATION IN EMPLOYMENT**

To: \_\_\_\_\_  
(Name of union or organization of workers)

The undersigned currently holds contract(s) with \_\_\_\_\_  
(name of applicant)

involving funds or credit of the U.S. Government or (a) subcontract(s) with a prime contractor holding such contract(s).

You are advised that under the provisions of the above contracts(s) or subcontract(s) and in accordance with Executive Order 11246, as amended, dated September 24, 1965, as amended, the undersigned is obliged not to discriminate against any employee or applicant for employment because of race, color, creed or national origin. This obligation not to discriminate in employment includes, but is not limited to, the following:

- HIRING, PLACEMENT, UPGRADING, TRANSFER OR DEMOTION, RECRUITMENT, ADVERTISING, OR SOLICITATION FOR EMPLOYMENT, TRAINING DURING EMPLOYMENT, RATES OF PAY OR OTHER FORMS OF COMPENSATION, SELECTION FOR TRAINING INCLUDING APPRENTICESHIP, LAYOFF OR TERMINATION.

This notice is furnished you pursuant to the provisions of the above contract(s) or subcontracts(s) and Executive Order 11246, as amended.

Copies of this notice will be posted by the undersigned in conspicuous places available to employees or applicants for employment.

\_\_\_\_\_  
\_\_\_\_\_  
\_\_\_\_\_  
\_\_\_\_\_  
(Contractor or Subcontractor)

\_\_\_\_\_  
(Date)

*This page intentionally left blank.*

## DAVIS BACON ACT GUIDANCE

BIDDER certifies that wages paid in connection with the PROJECT shall be paid at prevailing rates not less than those prevailing under the Davis-Bacon Wage Act. Bidder further certifies that the provisions contained in the following clauses will be exercised in the performance of any contract resulting from this BID and are made a part of the CONTRACT DOCUMENTS thereto by their inclusion in the BID as follows:

### **§5.5(a) Contract provisions and related matters.**

#### **(1) *Minimum wages.***

- (i) All laborers and mechanics employed or working upon the site of the work, will be paid unconditionally and not less often than once a week, and without subsequent deduction or rebate on any account (except such payroll deductions as are permitted by regulations issued by the Secretary of Labor under the Copeland Act (29 CFR part 3)), the full amount of wages and bona fide fringe benefits (or cash equivalents thereof) due at time of payment computed at rates not less than those contained in the wage determination of the Secretary of Labor which is attached hereto and made a part hereof, regardless of any contractual relationship which may be alleged to exist between the contractor and such laborers and mechanics. Contributions made or costs reasonably anticipated for bona fide fringe benefits under section 1(b)(2) of the Davis Bacon Act on behalf of laborers or mechanics are considered wages paid to such laborers or mechanics, subject to the provisions of paragraph (a)(1)(iv) of this section; also, regular contributions made or costs incurred for more than a weekly period (but not less often than quarterly) under plans, funds, or programs which cover the particular weekly period, are deemed to be constructively made or incurred during such weekly period. Such laborers and mechanics shall be paid the appropriate wage rate and fringe benefits on the wage determination for the classification of work actually performed, without regard to skill, except as provided in §5.5(a)(4). Laborers or mechanics performing work in more than one classification may be compensated at the rate specified for each classification for the time actually worked therein: Provided, that the employer's payroll records accurately set forth the time spent in each classification in which work is performed. The wage determination (including any additional classification and wage rates conformed under paragraph (a)(1)(ii) of this section) and the Davis Bacon poster (WH-1321) shall be posted at all times by the contractor and its subcontractors at the site of the work in a prominent and accessible place where it can be easily seen by the workers. Sub recipients may obtain wage determinations from the U.S. Department of Labor's web site, [www.dol.gov](http://www.dol.gov).
- (ii) (A) The sub-recipient, on behalf of USEPA, shall require that any class of laborers or mechanics, including helpers, which is not listed in the wage determination and which is to be employed under the contract shall be classified in conformance with the wage determination. The USEPA award official shall approve an additional classification and wage rate and fringe benefits therefore only when the following criteria have been met:
  - (1) The work to be performed by the classification requested is not performed by a classification in the wage determination; and
  - (2) The classification is utilized in the area by the construction industry; and

- (3) The proposed wage rate, including any bona fide fringe benefits, bears a reasonable relationship to the wage rates contained in the wage determination.

(B) If the contractor and the laborers and mechanics to be employed in the classification (if known), or their representatives, and the sub-recipient agree on the classification and wage rate (including the amount designated for fringe benefits where appropriate), a report of the action taken shall be sent by the sub-recipient to IEPA. IEPA shall forward the report to the Administrator of the Wage and Hour Division, U.S. Department of Labor, Washington, DC 20210. The Administrator, or an authorized representative, will approve, modify, or disapprove every additional classification action within 30 days of receipt and so advise IEPA or will notify IEPA within the 30-day period that additional time is necessary.

(C) In the even the contractor, the laborers or mechanics to be employed in the classification or their representatives, and the sub-recipient do not agree on the proposed classification and wage rate (including the amount designated for fringe benefits, where appropriate), IEPA shall refer the questions, including the views of all interested parties and the recommendation of the sub-recipient, to the Administrator for determination. The Administrator, or an authorized representative, will issue a determination within 30 days of receipt and so advise IEPA or will notify IEPA within the 30-day period that additional time is necessary.

(D) The wage rate (including fringe benefits where appropriate) determined pursuant to paragraphs (a)(1)(ii)(B) or (C) of this section, shall be paid to all workers performing work in the classification under this contract from the first day on which work is performed in the classification.

- (iii) Whenever the minimum wage rate prescribed in the contract for a class of laborers or mechanics includes a fringe benefit which is not expressed as an hourly rate, the contractor shall either pay the benefit as stated in the wage determination or shall pay another bona fide fringe benefit or an hourly cash equivalent thereof.
- (iv) If the contractor does not make payments to a trustee or other third person, the contractor may consider as part of the wages of any laborer or mechanic the amount of any costs reasonably anticipated in providing bona fide fringe benefits under a plan or program, Provided, that the Secretary of Labor has found, upon the written request of the contractor, that the applicable standards of the Davis Bacon Act have been met. The Secretary of Labor may require the contractor to set aside in a separate account assets for the meeting of obligations under the plan or program.
- (2) *Withholding.* The sub-recipient shall upon its own action or upon written request of an authorized representative of the Department of Labor withhold or cause to be withheld from the contractor under this contract or any other Federal contract with the same prime contractor, or any other federally-assisted contract subject to Davis Bacon prevailing wage requirements, which is held by the same prime contractor, so much of the accrued payments or advances as may be considered necessary to pay laborers and mechanics, including apprentices, trainees, and helpers, employed by the contractor or any subcontractor the full amount of wages required by the contract. In the event of failure to pay any laborer or mechanic, including any apprentice, trainee, or helper, employed or working on the site of

the work, all or part of the wages required by the contract, the sub-recipient may, after written notice to the contractor, sponsor, applicant, or owner, take such action as may be necessary to cause the suspension of any further payment, advance, or guarantee of funds until such violations have ceased.

(3) *Payrolls and basic records.*

- (i) Payrolls and basic records relating thereto shall be maintained by the contractor during the course of the work and preserved for a period of three years thereafter for all laborers and mechanics working at the site of the work. Such records shall contain the name, address, and social security number of each such worker, his or her correct classification, hourly rates of wages paid (including rates of contributions or costs anticipated for bona fide fringe benefits or cash equivalents thereof of the types described in section 1(b)(2)(B) of the Davis Bacon Act), daily and weekly number of hours worked, deductions made and actual wages paid. Whenever the Secretary of Labor has found under 29 CFR 5.5(a)(1)(iv) that the wages of any laborer or mechanic include the amount of any costs reasonably anticipated in providing benefits under a plan or program described in section 1(b)(2)(B) of the Davis Bacon Act, the contractor shall maintain records which show that the commitment to provide such benefits is enforceable, that the plan or program is financially responsible, and that the plan or program has been communicated in writing to the laborers or mechanics affected, and records which show the costs anticipated or the actual cost incurred in providing such benefits. Contractors employing apprentices or trainees under approved programs shall maintain written evidence of the registration of apprenticeship programs and certification of trainee programs, the registration of the apprentices and trainees, and the ratios and wage rates prescribed in the applicable programs.
- (ii) (A) The contractor shall submit weekly for each week in which any contract work is performed a copy of all payrolls to the sub-recipient. Such documentation shall be available upon request of IEPA or USEPA. The payrolls submitted shall set out accurately and completely all of the information required to be maintained under 29 CFR 5.5(a)(3)(i), except that full social security numbers and home addresses shall not be included on weekly transmittals. Instead the payrolls shall only need to include an individually identifying number for each employee (e.g., the last four digits of the employee's social security number). The required weekly payroll information may be submitted in any form desired. Optional Form WH-347 is available for this purpose from the Wage and Hour Division Web site at <https://www.dol.gov/whd/programs/dbra/wh347.htm> or its successor site [<https://www.dol.gov/whd/forms/index.htm>]. The prime contractor is responsible for the submission of copies of payrolls by all subcontractors. Contractors and subcontractors shall maintain the full social security number and current address of each covered worker, and shall provide them upon request to the sub-recipient, for transmission to the IEPA, USEPA, the contractor, or the Wage and Hour Division of the Department of Labor for purposes of an investigation or audit of compliance with prevailing wage requirements. It is not a violation of this section for a prime contractor to require a subcontractor to provide addresses and social security numbers to the prime contractor for its own records, without weekly submission to the sub-recipient. (B) Each payroll submitted shall be accompanied by a "Statement of Compliance," signed by the contractor or subcontractor or his or her agent who pays or supervises the payment of the persons employed under the contract and shall certify the following:

- (1) That the payroll for the payroll period contains the information required to be provided under §5.5 (a)(3)(ii) of Regulations, 29 CFR part 5, the appropriate information is being maintained under §5.5 (a)(3)(i) of Regulations, 29 CFR part 5, and that such information is correct and complete;
  - (2) That each laborer or mechanic (including each helper, apprentice, and trainee) employed on the contract during the payroll period has been paid the full weekly wages earned, without rebate, either directly or indirectly, and that no deductions have been made either directly or indirectly from the full wages earned, other than permissible deductions as set forth in Regulations, 29 CFR part 3;
  - (3) That each laborer or mechanic has been paid not less than the applicable wage rates and fringe benefits or cash equivalents for the classification of work performed, as specified in the applicable wage determination incorporated into the contract.
- (C) The weekly submission of a properly executed certification set forth on the reverse side of Optional Form WH-347 shall satisfy the requirement for submission of the "Statement of Compliance" required by paragraph (a)(3)(ii)(B) of this section.
- (D) The falsification of any of the above certifications may subject the contractor or subcontractor to civil or criminal prosecution under section 1001 of title 18 and section 231 of title 31 of the United States Code.
- (iii) The contractor or subcontractor shall make the records required under paragraph (a)(3)(i) of this section available for inspection, copying, or transcription by authorized representatives of IEPA, USEPA or the Department of Labor, and shall permit such representatives to interview employees during working hours on the job. If the contractor or subcontractor fails to submit the required records or to make them available, the Federal agency may, after written notice to the contractor, sponsor, applicant, or owner, take such action as may be necessary to cause the suspension of any further payment, advance, or guarantee of funds. Furthermore, failure to submit the required records upon request or to make such records available may be grounds for debarment action pursuant to 29 CFR 5.12.

(4) *Apprentices and trainees*

(i) *Apprentices.* Apprentices will be permitted to work at less than the predetermined rate for the work they performed when they are employed pursuant to and individually registered in a bona fide apprenticeship program registered with the U.S. Department of Labor, Employment and Training Administration, Office of Apprenticeship Training, Employer and Labor Services, or with a State Apprenticeship Agency recognized by the Office, or if a person is employed in his or her first 90 days of probationary employment as an apprentice in such apprenticeship program, who is not individually registered in the program, but who has been certified by the Office of Apprenticeship Training, Employer and Labor Services, or a State Apprenticeship Agency (where appropriate) to be eligible for probationary employment as an apprentice. The allowable ratio of apprentices to journeymen on the job site in any craft classification shall not be greater than the ratio permitted to the contractor as to the entire work force under the registered program.

Any worker listed on a payroll at an apprentice wage rate, who is not registered or otherwise employed as stated above, shall be paid not less than the applicable wage rate on the wage determination for the classification of work actually performed. In addition, any apprentice performing work on the job site in excess of the ratio permitted under the registered program shall be paid no less than the applicable wage rate on the wage determination for the work actually performed. Where a contractor is performing construction on a project in a locality other than that in which its program is registered, the ratios and wage rates (expressed in percentages of the journeyman's hourly rate) specified in the contractor's or subcontractor's registered program shall be observed. Every apprentice must be paid at not less than the rate specified in the registered program for the apprentice's level of progress, expressed as a percentage of the journeymen hourly rate specified in the applicable wage determination. Apprentices shall be paid fringe benefits in accordance with the provisions of the apprenticeship program. If the apprenticeship program does not specify fringe benefits, apprentices must be paid the full amount of fringe benefits listed on the wage determination for the applicable classification. If the Administrator determines that a different practice prevails for the applicable apprentice classification, fringes shall be paid in accordance with that determination. In the event the Office of Apprenticeship Training, Employer and Labor Services, or a State Apprenticeship Agency recognized by the Office, withdraws approval of an apprenticeship program, the contractor will no longer be permitted to utilize apprentices at less than the applicable predetermined rate for the work performed until an acceptable program is approved.

- (ii) *Trainees. Except as provided in 29 CFR 5.16, trainees will not be permitted to work at less than the predetermined rate for the work performed unless they are employed pursuant to and individually registered in a program which has received prior approval, evidenced by form certification by the U.S. Department of Labor, Employment and Training Administration. The ratio of trainees to journeymen on the job site shall not be greater than permitted under the plan approved by the Employment and Training Administration. Every trainee must be paid at not less than the rate specified in the approved program for the trainee's level of progress, expressed as a percentage of the journeyman hourly rate specified in the applicable wage determination. Trainees shall be paid fringe benefits in accordance with the provisions of the trainee program. If the trainee program does not mention fringe benefits, trainees shall be paid the full amount of fringe benefits listed on the wage determination unless the Administrator of the Wage and Hour Division determines that there is an apprenticeship program associated with the corresponding journeyman wage rate on the wage determination which provides for less than full fringe benefits for apprentices. Any employee listed on the payroll at a trainee rate who is not registered and participating in a training plan approved by the Employment and Training Administration shall be paid not less than the applicable wage rate on the wage determination for the classification of work actually performed. In addition, any trainee performing work on the job site in excess of the ratio permitted under the registered program shall be paid not less than the applicable wage rate on the wage determination for the work actually performed. In the event the Employment and Training Administration withdraws approval of a training program, the contractor will no longer be permitted to utilize trainees at less than the applicable predetermined rate for the work performed until an acceptable program is approved.*

- (iii) *Equal employment opportunity. The utilization of apprentices, trainees and journeymen under this part shall be in conformity with the equal employment opportunity requirements of Executive Order 11246, as amended, and 29 CFR part 30.*
- (5) *Compliance with Copeland Act requirements.* The contractor shall comply with the requirements of 29 CFR part 3, which are incorporated by reference in this contract.
- (6) *Subcontracts.* The contractor or subcontractor shall insert in any subcontracts the clauses contained in 29 CFR 5.5(a)(1) through (10) and such other clauses as the USEPA may by appropriate instruction require, and also a clause requiring the subcontractors to include these clauses in any lower tier subcontracts. The prime contractor shall be responsible for the compliance by any subcontractor or lower tier subcontractor with all the contract clauses in 29 CFR 5.5.
- (7) *Contract termination: debarment.* A breach of the contract clauses in 29 CFR 5.5 may be grounds for termination of the contract, and for debarment as a contractor and a subcontractor as provided in 29 CFR 5.12.
- (8) *Compliance with Davis Bacon and Related Act requirements.* All rulings and interpretations of the Davis Bacon and Related Acts contained in 29 CFR parts 1, 3, and 5 are herein incorporated by reference in this contract.
- (9) *Disputes concerning labor standards.* Disputes arising out of the labor standards provisions of this contract shall not be subject to the general disputes clause of this contract. Such disputes shall be resolved in accordance with the procedures of the Department of Labor set forth in 29 CFR parts 5, 6, and 7. Disputes within the meaning of this clause include disputes between the contractor (or any of its subcontractors) and the contracting agency, the U.S. Department of Labor, or the employees or their representatives.
- (10) *Certification of eligibility.*
- (i) By entering into this contract, the contractor certifies that neither it (nor he or she) nor any person or firm who has an interest in the contractor's firm is a person or firm ineligible to be awarded Government contracts by virtue of section 3(a) of the Davis Bacon Act or 29 CFR 5.12(a)(1).
  - (ii) No part of this contract shall be subcontracted to any person or firm ineligible for award of a Government contract by virtue of section 3(a) of the Davis Bacon Act or 29 CFR 5.12(a)(1).
  - (iii) The penalty for making false statements is prescribed in the U.S. Criminal Code, 18 U.S.C. 1001

**§5.5(b) Contract Work Hours and Safety Standards Act**

- (1) *Overtime requirements.* No contractor or subcontractor contracting for any part of the contract work which may require or involve the employment of laborers or mechanics shall require or permit any such laborer or mechanic in any workweek in which he or she is employed on such work to work in excess of forty hours in such workweek unless such laborer or mechanic receives compensation at a rate not less than one and one-half times the basic rate of pay for all hours worked in excess of forty hours in such workweek.

- (2) *Violation; liability for unpaid wages; liquidated damages.* In the event of any violation of the clause set forth in paragraph (b)(1) of this section the contractor and any subcontractor responsible therefor shall be liable for the unpaid wages. In addition, such contractor and subcontractor shall be liable to the United States (in the case of work done under contract for the District of Columbia or a territory, to such District or to such territory), for liquidated damages. Such liquidated damages shall be computed with respect to each individual laborer or mechanics, including watchmen and guards, employed in violation of the clause set forth in paragraph (b)(1) of this section, in the sum of \$25 for each calendar day on which such individual was required or permitted to work in excess of the standard workweek of forty hours without payment of the overtime wages required by the clause set forth in paragraph (b)(1) of this section.
- (3) *Withholding for unpaid wages and liquidated damages.* The sub-recipient, shall upon its own action or upon written request of the USEPA award official or an authorized representative of the Department of Labor, withhold or cause to be withheld, from any moneys payable on account of work performed by the contractor or subcontractor under any such contract or any other Federal contract with the same prime contractor, or any other federally-assisted contract subject to the Contract Work Hours and Safety Standards Act, which is held by the same prime contractor, such sums as may be determined to be necessary to satisfy any liabilities of such contractor or subcontractor for unpaid wages and liquidated damages as provided in the clause set forth in paragraph (b)(2) of this section.
- (4) *Subcontracts.* The contractor or subcontractor shall insert in any subcontracts the clauses set forth in paragraph (b)(1) through (4) of this section and also a clause requiring the subcontractors to include these clauses in any lower tier subcontracts. The prime contractor shall be responsible for compliance by any subcontractor or lower tier subcontractor with the clauses set forth in paragraphs (b)(1) through (4) of this section.

**§5.5(c)** The contractor or subcontractor shall maintain payrolls and basic payroll records during the course of the work and shall preserve them for a period of three years from the completion of the contract for all laborers and mechanics, including guards and watchmen, working on the contract. Such records shall contain the name and address of each such employee, social security number, correct classifications, hourly rates of wages paid, daily and weekly number of hours worked, deductions made, and actual wages paid. Further, the records to be maintained under this paragraph shall be made available by the contractor or subcontractor for inspection, copying, or transcription by authorized representatives of the USEPA and the Department of Labor, and the contractor or subcontractor will permit such representatives to interview employees during working hours on the job.

***This page intentionally left blank.***

**NOTICE OF INTENT TO AWARD**

To: \_\_\_\_\_  
\_\_\_\_\_  
\_\_\_\_\_

Project Description: Village of Villa Park, 2019 Sewer Rehabilitation Program,

\_\_\_\_\_  
\_\_\_\_\_

The OWNER has considered the BID submitted by you for the above described WORK, in response to its Advertisement for Bids, dated \_\_\_\_\_ and Information for Bidders.

You are hereby notified that your BID will be accepted, contingent upon Illinois Environmental Protection Agency (IEPA) approval, for items in the amount of \_\_\_\_\_.

You will be required by the Information for Bidders to execute the Agreement and furnish the required CONTRACTOR'S Performance BOND, Payment BOND and certificates of insurance within ten (10) calendar days from the date of the final Notice to be sent upon IEPA approval, to you.

Dated this \_\_\_\_\_ day of \_\_\_\_\_.

\_\_\_\_\_  
OWNER

By: \_\_\_\_\_

Title: \_\_\_\_\_

*This page intentionally left blank.*

**NOTICE OF AWARD**

TO: \_\_\_\_\_  
\_\_\_\_\_  
\_\_\_\_\_

DATE: \_\_\_\_\_

PROJECT DESCRIPTION: Village of Villa Park, Illinois;  
2019 Sewer Rehabilitation Program

The Owner has considered the BID submitted by you for the above referenced project in response to the Notice to Contractors dated \_\_\_\_\_, 2019

You are hereby notified that your bid has been accepted for items in the amount of \$\_\_\_\_\_. You are required by the Instructions to Bidders to execute the Agreement and furnish the required CONTRACTOR'S Performance BOND, Payment BOND and Certificates of Insurance within ten (10) calendar days from the date of this Notice to you.

If you fail to execute said Agreement and to furnish said BONDS within fifteen (15) days from the date of this Notice, OWNER will be entitled to consider all your rights arising out of the OWNER's acceptance of your bid as abandoned and as a forfeiture of your BID BOND. The OWNER will be entitled to such other rights as may be granted by law.

You are required to return an acknowledged copy of this NOTICE OF AWARD to the OWNER.

Village of Villa Park, Illinois

By \_\_\_\_\_

Title \_\_\_\_\_

**ACCEPTANCE OF NOTICE**

Receipt of the Above NOTICE TO PROCEED is hereby acknowledged by

this the \_\_\_\_\_ day

of \_\_\_\_\_, 2019

By \_\_\_\_\_

Title \_\_\_\_\_

*This page intentionally left blank.*

## CONTRACT

This Contract is made this 13<sup>th</sup> day of December, 2019, between the Village of Villa Park, the Village, and Michels Corporation, the Contractor, for the **2019 SEWER REHABILITATION PROGRAM**.

The Contractor hereby agrees as hereinafter set forth:

**1. The Work**

For and in consideration of the payments to be made by the Village to the Contractor, and according to the terms of the Contract, the Village and the Contractor agree that the Contractor at its own proper cost and expense shall perform all of the work required for the **2019 SEWER REHABILITATION PROGRAM**, in the Village of Villa Park, DuPage County, Illinois, and to furnish all materials and labor necessary to complete the Work and in full compliance with all of the terms and the requirements of this agreement in strict compliance with the contract documents, which contract documents are made an essential part of this Contract.

**2. Contract Sum**

The Village shall pay the Contractor for the performance of the work, at the unit prices set forth in the Contractor's Proposal as full compensation for furnishing all the materials, for doing all work contemplated and specified in this contract, for all loss or damage arising out of the nature of the work or from any action of the elements, or from any unforeseen difficulties which may be encountered in the prosecution of the same, for all risks of every description connected with the work, and for well and faithfully completing the work, and the whole thereof, in full compliance with the plans and contract documents, and within the time stated in the Proposal, hereby made a part of hereof, which time is hereby declared to be of the essence of this contract. The undersigned Contractor declares that it understands that the quantities shown in the Proposal are approximate only and that they are subject to increase or decrease; and agrees that it will take, in full payment, the amount of the summation of the actual quantities, as finally determined, multiplied by the unit prices shown on the schedule of prices forming a part of this Contract.

**3. Contract Time**

The Work will commence expeditiously after the date the Village gives the Contractor written notice to proceed. The work shall be substantially completed within one hundred fifty (150) calendar days and final completion shall be within one hundred eighty (180) calendar days after the date of such notice, unless an extension of time is granted in accordance with the Specifications.

**4. Payments**

Partial payment, acceptance, and final payment is to be made to the Contractor in accordance with and subject to the provisions embodied in the General Conditions, which are made a part of this Contract. The Village shall approve payment of and pay to the Contractor any and all fees, charges and amounts due to Contractor for services performed prior to the termination consistent with the requirements of the Local Government Prompt Payment Act (50 ILCS 505/4 *et seq.*). The Contractor shall comply with the requirements of the Local Government Prompt Payment Act (50 ILCS 505/4, *et seq.*).

**5. Assignment of Contract**

The Contract shall be deemed to be exclusive between Village and Contractor. This Contract shall not be assigned by the Contractor without first obtaining permission in writing from the Village. The Village may refuse to accept any substitute Contractor for any reason.

**6. Notices**

Written notices between Village and Contractor shall be deemed sufficiently given after being placed in the United States mail, registered or certified, postage pre-paid, addressed to the above parties as follows:

a. If to Village:

Village of Villa Park  
Public Works Department  
20 South Ardmore Avenue  
Villa Park, Illinois 60181  
Attn: Rich Salerno

b. If to Contractor:

Michels Pipe Services: a division of Michels Corporation  
817 Main Street, PO Box 128  
Brownsville, LA 70006  
Attn: Mike Figlio

c. Either party may change its mailing address by giving written notice to the other party as provided above. Whenever this Contract requires one party to give the other notice, such notice shall be given only in the form and to the addresses described in this paragraph.

**7. Entire Contract.**

This Contract consists of the following component parts, all of which are as fully a part of this Contract as if herein set out verbatim, or if not attached, as if attached hereto:

- (a) Addenda, if any (none unless indicated here) 1
- (b) Notice to Bidders and Invitation for Bids
- (c) Instructions to Bidders
- (d) Contractor's Certification
- (e) References
- (f) IEPA Required Certifications
- (g) Bid
- (h) Bid Bond
- (i) Contract
- (j) Payment Bond
- (k) Performance Bond
- (l) Notice of Award
- (m) Notice to Proceed
- (n) Change Order
- (o) Plans and Specifications
- (p) Special Provisions
- (q) Attachments
- (r) EJCDC – Latest Edition Wording

- (s) The "Standard Specifications for Sewer and Water Main Construction in Illinois" Sixth Edition, July 2009 excluding Sections 2, 3, 4, 5, 6, 7, 8 and 9 of Division I General Requirements and Covenants (hereinafter referred to as the "Standard Specifications for Sewer and Water Main Construction") are hereby incorporated by reference and shall apply to and govern the construction of all sewer and water main work of the **2019 Sewer Rehabilitation Program**, DuPage County, Illinois.

This Contract represents the entire and integrated Contract between the parties and supersedes all prior negotiations, representations or understandings, whether written or oral.

Noted: Contract documents (n) and (o), are separate books that will not be furnished by the Village but shall be the responsibility of the Contractor to obtain at its own expense. Contract document (n) may be obtained from the Illinois Department of Transportation. See <http://www.idot.illinois.gov/doing-business/index>.

Contract document (o) may be obtained from the Illinois Society of Professional Engineers. See [https://www.illinoisengineer.com/IllinoisEngineer/Shop/Standard\\_Specs/IllinoisEngineer/Standard\\_Specs.aspx](https://www.illinoisengineer.com/IllinoisEngineer/Shop/Standard_Specs/IllinoisEngineer/Standard_Specs.aspx)

In case of conflict between the terms contained herein and those contained in the General Conditions, the terms herein shall control. This Contract may only be amended or a provision hereof waived by the parties by written instrument executed by authorized signatories of the Village and Contractor. This Contract is executed that day and year first written above.

#### **8. Contractor Investigation**

The Contractor represents that it has, before executing this Contract, carefully examined the provisions of this Contract, inspected in detail the site of the proposed Work, investigated and become familiar with all the local conditions affecting the contract and is fully acquainted with the detailed requirements of the Work. By executing this Contract the Contractor conclusively assures and warrants to the Village that it has made these examinations and that it understands all requirements for the performance of the Work. The Contractor shall be responsible for all errors resulting from its failure or neglect to comply with the provisions of the Contract and agrees that the Village will, in no case, be responsible for any costs, expenses, losses, or change in anticipated profits resulting from a failure or neglect of the Contractor to make these examinations.

#### **9. Contract and Subcontract Provisions – Prevailing Wage Requirements.**

##### **(1) Minimum wages.**

(i) All laborers and mechanics employed or working upon the site of the work will be paid unconditionally and not less often than once a week, and without subsequent deduction or rebate on any account (except such payroll deductions as are permitted by regulations issued by the Secretary of Labor under the Copeland Act (29 CFR part 3), the full amount of wages and bona fide fringe benefits (or cash equivalents thereof) due at time of payment computed at rates not less than those contained in the wage determination of the Secretary of Labor which is attached hereto and made a part hereof, regardless of any contractual relationship which may be alleged to exist between the Contractor and such laborers and mechanics.

Contributions made or costs reasonably anticipated for bona fide fringe benefits under section 1(b)(2) of the Davis-Bacon Act on behalf of laborers or mechanics are considered wages paid to such laborers or mechanics, subject to the provisions of paragraph (a)(1)(iv) of this section; also, regular contributions made or costs incurred for more than a weekly period (but not less than quarterly) under plans, funds, or

programs which cover the particular weekly period, are deemed to be constructively made or incurred during such weekly period. Such laborers and mechanics shall be paid the appropriate wage rate and fringe benefits on the wage determination for the classification of work actually performed, without regard to skill, except as provided in § 5.5(a)(4). Laborers or mechanics performing work in more than one classification may be compensated at the rate specified for each classification for the time actually worked therein: Provided, that the employer's payroll records accurately set forth the time spent in each classification in which work is performed. The wage determination (including any additional classification and wage rates conformed under paragraph (a)1(ii) of this section) and the Davis-Bacon poster (WH-1321) shall be posted at all times by the Contractor and its subcontractors at the site of the work in a prominent and accessible place where it can be easily seen by the workers.

Subrecipients may obtain wage determination from the U.S. Department of Labor's web site, [www.wdol.gov](http://www.wdol.gov).

(ii)(A) The subrecipient, on behalf of USEPA, shall require that any class of laborers or mechanics, including helpers, which is not listed in the wage determination and which is to be employed under the contract shall be classified in conformance with the wage determination. The USEPA award official shall approve an additional classification and wage rate and fringe benefits therefore only when the following criteria have been met:

(1) The work to be performed by the classification requested is not performed by a classification in the wage determination; and

(2) The classification is utilized in the area by the construction industry; and

(3) The proposed wage rate, including any bona fide fringe benefits, bears a reasonable relationship to the wage rates contained in the wage determination.

(B) If the Contractor and the laborers and mechanics to be employed in the classification (if known), or their representatives, and the subrecipient agree on the classification and wage rate (including the amount designated for fringe benefits where appropriate), a report of the action taken shall be sent by the subrecipient to IEPA. IEPA will transmit the report, to the Administrator of the Wage and Hour Division, Employment Standards Administration, U.S. Department of Labor, Washington, DC 20210. The Administrator, or an authorized representative, will approve, modify or disapprove every additional classification action within 30 days of receipt and so advise IEPA or will notify IEPA within the 30-day period that additional time is necessary.

(C) In the event the Contractor, the laborers or mechanics to be employed in the classification or their representatives, and the subrecipient do not agree on the proposed classification and wage rate (including the amount designated for fringe benefits, where appropriate), the award official shall refer the questions, including the views of all interested parties and the recommendation of the award official, to the Administrator for determination. The Administrator, or an authorized representative, will issue a determination within 30 days of receipt and so advise the contracting officer or will notify the contracting officer within the 30-day period that additional time is necessary.

(D) The wage rate (including fringe benefits where appropriate) determined pursuant to paragraphs (a)(1)(ii)(B) or (C) of this section, shall be paid to all workers performing work in the classification under this contract from the first day on which work is performed in the classification.

(iii) Whenever the minimum wage rate prescribed in the contract for a class of laborers or mechanics includes a fringe benefit which is not expressed as an hourly rate, the Contractor shall either pay the benefit as stated in the wage determination or shall pay another bona fide fringe benefit or an hourly cash equivalent thereof.

(iv) If the Contractor does not make payments to a trustee or other third person, the Contractor may consider as part of the wages of any laborer or mechanic the amount of any costs reasonably anticipated in providing bona fide fringe benefits under a plan or program. Provided, that the Secretary of Labor has found, upon the written request of the Contractor, that the applicable standards of the Davis-Bacon Act have been met. The Secretary of Labor may require the Contractor to set aside in a separate account assets for the meeting of obligations under the plan or program.

(2) Withholding, the subrecipient shall upon written request of the USEPA Award Official or an authorized representative of the Department of Labor withhold or cause to be withheld from the Contractor under this contract or any other Federal contract with the same prime Contractor, or any other federally-assisted contract subject to Davis-Bacon prevailing wage requirements, which is held by the same prime Contractor, so much of the accrued payments or advances as may be considered necessary to pay laborers and mechanics, including apprentices, trainees, and helpers, employed by the Contractor or any subContractor the full amount of wages required by the contract. In the event of failure to pay any laborer or mechanic, including any apprentice, trainee, or helper, employed or working on the site of the work, all or part of the wages required by the contract, the (Agency) may, after written notice to the Contractor, sponsor, applicant, or owner, take such actions as may be necessary to cause the suspension of any further payment, advance, or guarantee of funds until such violations have ceased.

(3) Payrolls and basic records.

(i) Payrolls and basic records relating thereto shall be maintained by the Contractor during the course of the work and preserved for a period of three years thereafter for all laborers and mechanics working at the site of the work. Such records shall contain the name, address, and social security number of each such worker, his or her correct classification, hourly rates of wages paid (including rates of contributions or costs anticipated for bona fide fringe benefits or cash equivalents thereof of the types described in section 1(b)(2)(B) of the Davis-Bacon Act), daily and weekly number of hours worked, deductions made and actual wages paid. Whenever the Secretary of Labor has found under 29 CFR 5.5(a)(1)(iv) that the wages of any laborer or mechanic include the amount of any costs reasonably anticipated in providing benefits under a plan or program described in section 1(b)(2)(B) of the Davis-Bacon Act, the Contractor shall maintain records which show that the commitment to provide such benefits is enforceable, that the plan or program is financially responsible, and that the plan or program has been communicated in writing to the laborers or mechanics affected, and records which show the costs anticipated or the actual cost incurred in providing such benefits. Contractors employing apprentices or trainees under approved programs shall maintain written evidence of the registration of apprenticeship programs and certification of trainee programs, the registration of the apprentices and trainees, and the ratios and wage rates prescribed in the applicable programs.

(ii)(A) The Contractor shall submit weekly for each week in which any contract work is performed a copy of all payrolls to the subrecipient, that is, the entity that receives the sub-grant or loan from IEPA. Such documentation shall be available on request of IEPA or USEPA. As to each payroll copy received, the subrecipient shall provide written confirmation in a form satisfactory to IEPA indicating whether or not the project is in compliance with the requirements of 29 CFR 5.5(a)(1) based on the most recent payroll copies for the specified week. The payrolls shall set out accurately and completely all of the information required to be maintained under 29 CFR 5.5(a)(3)(i), except that full social security numbers and home addresses shall not be included on the weekly payrolls. Instead the payrolls shall only need to include an individually identifying number for each employee (e.g., the last four digits of the employee's social security number). Form WH-347 is available for this purpose from the Wage and Hour Division Web site at <http://www.dol.gov/whd/forms/wh347instr.htm> or its successor site. The prime Contractor is responsible for the submission of copies of payrolls by all subcontractors. Contractors and subContractors shall maintain the full social security number and current address of each covered worker, and shall provide them upon request to the subrecipient for transmission to IEPA or USEPA, if

requested by USEPA, the Contractor, or the Wage and Hour Division of the Department of Labor for purposes of an investigation or audit of compliance with prevailing wage requirements. It is not a violation of this section for a prime Contractor to require a subcontractor to provide addresses and social security numbers to the prime Contractor for its own records, without weekly submission to the subrecipient.

(B) Each payroll submitted shall be accompanied by a "Statement of Compliance," signed by the Contractor or subcontractor or his or her agent who pays or supervises the payment of the persons employed under the contract and shall certify the following:

(1) That the payroll for the payroll period contains the information required to be provided under § 5.5 (a)(3)(ii) of Regulations, 29 CFR Part 5, the appropriate information is being maintained under § 5.5 (a)(3)(i) of Regulations, 29 CFR Part 5, and that such information is correct and complete.

(2) That each laborer and mechanic (including each helper, apprentice, and trainee) employed on the contract during the payroll period has been paid the full weekly wages earned, without rebate, either directly or indirectly, and that no deductions have been made either directly or indirectly from the full wages earned, other than permissible deductions as set forth in Regulations, 29 CFR Part 3;

(3) That each laborer or mechanic has been paid not less than the applicable wage rates and fringe benefits or cash equivalents for the classification of work performed, as specified in the applicable wage determination incorporated into the contract.

(C) The weekly submission of a properly executed certification set forth on the reverse side of Optional Form WH-347 shall satisfy the requirement for submission of the "Statement of Compliance" required by paragraph (a)(3)(ii)(B) of this section.

(D) The falsification of any of the above certifications may subject the Contractor or subcontractor to civil or criminal prosecution under section 1001 of title 18 and section 231 of title 31 of the United States Code.

(iii) The Contractor or subcontractor shall make the records required under paragraph (a)(3)(i) of this section available for inspection, copying, or transcription by authorized representatives of IEPA, USEPA or the Department of Labor, and shall permit such representatives to interview employees during working hours on the job. If the Contractor or subcontractor fails to submit the required records or to make them available, the Federal agency or IEPA may, after written notice to the Contractor, sponsor, applicant, or owner, take such action as may be necessary to cause the suspension of any further payment, advance, or guarantee of funds. Furthermore, failure to submit the required records upon request or to make such records available may be grounds for debarment action pursuant to 29 CFR 5.12.

(4) Apprentices and trainees –

(i) Apprentices. Apprentices will be permitted to work at less than predetermined rate for the work they performed when they are employed pursuant to and individually registered in a bona fide apprenticeship program registered with the U.S. Department of Labor, Employment and Training Administration, Office of Apprenticeship Training, Employer and Labor Services, or with a State Apprenticeship Agency recognized by the Office, or if a person is employed in his or her first 90 days of probationary employment as an apprentice in such an apprenticeship program, who is not individually registered in the program, but who has been certified by the Office of Apprenticeship Training, Employer and Labor Services or a State Apprenticeship Agency (where appropriate) to be eligible for probationary employment as an apprentice. The allowable ratio of apprentices to journeymen on the job site in any craft classification shall not be greater than the ratio permitted to the Contractor as to the entire work force under the registered program. Any worker listed on a payroll at an apprentice wage rate, who is not registered or otherwise employed as stated above, shall be paid not less than the applicable wage rate

on the wage determination for the classification of work actually performed. In addition, any apprentice performing work on the job site in excess of the ratio permitted under the registered program shall be paid not less than the applicable wage rate on the wage determination for the work actually performed. Where a Contractor is performing construction on a project in a locality other than that in which its program is registered, the ratios and wage rates (expressed in percentages of the journeyman's hourly rate) specified in the Contractor's or subcontractor's registered program shall be observed. Every apprentice must be paid at not less than the rate specified in the registered program for the apprentice's level of progress, expressed as a percentage of the journeymen hourly rate specified in the applicable wage determination. Apprentices shall be paid fringe benefits in accordance with the provisions of the apprenticeship program. If the apprenticeship program does not specify fringe benefits, apprentices must be paid the full amount of fringe benefits listed on the wage determination for the applicable classification. If the Administrator determines that a different practice prevails for the applicable apprentice classification, fringes shall be paid in accordance with that determination. In the event the Office of Apprenticeship Training, Employer and Labor Services, or a State Apprenticeship Agency recognized by the Office, withdraws approval of an apprenticeship program, the Contractor will no longer be permitted to utilize apprentices at less than the applicable predetermined rate for the work performed until an acceptable program is approved.

(ii) Trainees. Except as provided in 29 CFR 5.16, trainees will not be permitted to work at less than the predetermined rate for the work performed unless they are employed pursuant to and individually registered in a program which has received prior approval, evidenced by formal certification by the U.S. Department of Labor, Employment and Training Administration. The ratio of trainees to journeymen on the job site shall not be greater than permitted under the plan approved by the Employment and Training Administration. Every trainee must be paid at not less than the rate specified in the approved program for the trainee's level of progress, expressed as a percentage of the journeyman hourly rate specified in the applicable wage determination. Trainees shall be paid fringe benefits in accordance with the provisions of the trainee program. If the trainee program does not mention fringe benefits, trainees shall be paid the full amount of fringe benefits listed on the wage determination unless the Administrator of the Wage and Hour Division determines that there is an apprenticeship program associated with the corresponding journeyman wage rate on the wage determination which provides for less than full fringe benefits for apprentices. Any employee listed on the payroll at a trainee rate who is not registered and participating in a training plan approved by the Employment and Training Administration shall be paid not less than the applicable wage rate on the wage determination for the classification of work actually performed. In addition, any trainee performing work on the job site in excess of the ratio permitted under the registered program shall be paid not less than the applicable wage rate on the wage determination for the work actually performed. In the event the Employment and Training Administration withdraws approval of a training program, the Contractor will no longer be permitted to utilize trainees at less than the applicable predetermined rate for the work performed until an acceptable program is approved.

(iii) Equal employment opportunity. The utilization of apprentices, trainees and journeymen under this part shall be in conformity with the equal employment opportunity requirements of Executive Order 11246, as amended, and 29 CFR part 30.

(5) Compliance with Copeland Act requirements. The Contractor shall comply with the requirements of 29 CFR part 3, which are incorporated by reference in this contract.

(6) Subcontracts. The Contractor or subcontractor shall insert in any subcontracts the clauses contained in 29 CFR 5.5(a)(1) through (10) and such other clauses as the USEPA determines may be appropriate, and also a clause requiring the subcontractors to include these clauses in any lower tier subcontracts. The prime Contractor shall be responsible for the compliance by any subcontractor or lower tier subcontractor with all the contract clauses in 29 CFR 5.5.

(7) Contract termination: debarment. A breach of the contract clauses in 29 CFR 5.5 may be grounds for termination of the contract, and for debarment as a Contractor and a subcontractor as provided in 29 CFR 5.12.

(8) Compliance with Davis-Bacon and Related Act requirements. All rulings and interpretations of the Davis-Bacon and Related Acts contained in 29 CFR parts 1, 3, and 5 are herein incorporated by reference in this contract.

(9) Disputes concerning labor standards. Disputes arising out of the labor standards provisions of this contract shall not be subject to the general disputes clause of this contract. Such disputes shall be resolved in accordance with the procedures of the Department of Labor set forth in 29 CFR parts 5, 6, and 7. Disputes within the meaning of this clause include disputes between the Contractor (or any of its subcontractors) and subrecipients, IEPA, USEPA, the U.S. Department of Labor, or the employees or their representatives.

(10) Certification of eligibility.

(i) By entering into this contract, the Contractor certifies that neither it (nor he or she) nor any person or firm who has an interest in the Contractor's firm is a person or firm ineligible to be awarded Government contracts by virtue of section 3(a) of the Davis-Bacon Act or 29 CFR 5.12(a)(1).

(ii) No part of this contract shall be subcontracted to any person or firm ineligible for award of a Government contract by virtue of section 3(a) of the Davis-Bacon Act or 29 CFR 5.12(a)(1).

(iii) The penalty for making false statements is prescribed in the U.S. Criminal Code, 18 U.S.C. 1001.

(1) Overtime requirements. No Contractor or subcontractor contracting for any part of the contract work which may require or involve the employment of laborers or mechanics shall require or permit any such laborer or mechanic in any workweek in which he or she is employed on such work to work in excess of forty hours in such workweek unless such laborer or mechanic receives compensation at a rate not less than one and one-half times the basic rate of pay for all hours worked in excess of forty hours in such workweek.

(2) Violation; liability for unpaid wages; liquidated damages. In the event of any violation of the clause set forth in paragraph (b)(1) of this section the Contractor and any subcontractor responsible therefore shall be liable to the United States (in the case of work done under contract for the District of Columbia or a territory, to such District or to such territory), for liquidated damages. Such liquidated damages shall be computed with respect to each individual laborer or mechanic, including watchmen and guards, employed in violation of the clauses set forth in paragraph (b)(1) of this section, in the sum of \$10 for each calendar day on which such individual was required or permitted to work in excess of the standard workweek of forty hours without payment of the overtime wages required by the clause set forth in paragraph (b)(1) of this section.

(3) Withholding for unpaid wages and liquidated damages. The subrecipient, upon written request of the USEPA Award Official or an authorized representative of the Department of Labor, shall withhold or cause to be withheld, from any moneys payable on account of work performed by the Contractor or subcontractor under any such contract or any other Federal contract with the same prime Contractor, or any other federally-assisted contract subject to the Contract Work Hours and Safety Standards Act, which is held by the same prime Contractor, such sums as may be determined to be necessary to satisfy any liabilities of such Contractor or subcontractor for unpaid wages and liquidated damages as provided in the clause set forth in paragraph (b)(2) of this section.

(4) Subcontracts. The Contractor or subcontractor shall insert in any subcontracts the clauses set forth in paragraph (b)(1) through (4) of this section and also a clause requiring the subcontractors to include these clauses in any lower tier subcontracts. The prime Contractor shall be responsible for compliance by any subcontractor or lower tier subcontractor with the clauses set forth in paragraphs (b)(1) through (4) of this section.

(b) In addition to the clauses contained in Item 3, above, in any contract subject only to the Contract Work Hours and Safety Standards Act and not to any of the other statutes cited in 29 CFR 5.1, the Subrecipient shall insert a clause requiring that the Contractor or subcontractor shall maintain payrolls and basic payroll records during the course of the work and shall preserve them for a period of three years from the completion of the contract for all laborers and mechanics, including guards and watchmen, working on the contract. Such records shall contain the name and address of each such employee, social security number, correct classifications, hourly rates of wages paid, daily and weekly number of hours worked, deductions made, and actual wages paid. Further, the Subrecipient shall insert in any such contract a clause providing that the records to be maintained under this paragraph shall be made available by the Contractor or subcontractor for inspection, copying, or transcription by authorized representatives of the IEPA, USEPA and the Department of Labor, and the Contractor or subcontractor will permit such representatives to interview employees during working hours on the job.

#### **10. Audit; Access to Records**

A) The Contractor shall maintain books, records, documents and other evidence directly pertinent to performance on loan work consistent with generally accepted accounting standards in accordance with the American Institute of Certified Public Accountants Professional Standards. The Contractor shall also maintain the financial information and data used by the Contractor in the preparation or support of any cost submissions required under subsection (c) above, (Negotiation of Contract Amendments, Change Orders) and a copy of the cost summary submitted to the owner. The Illinois Auditor General, the owner, the Agency, or any of their authorized representatives shall have access to the books, records, documents, and other evidence for purposes of inspection, audit, and copying. The Contractor shall provide facilities for access and inspection.

B) For a formally advertised, competitively awarded, fixed price contract, the Contractor shall include access to records as specified in subsection (A) above for all negotiated change orders and contract amendments in excess of \$25,000 that affect the contract price. In the case of all other prime contracts, the Contractor shall agree to include access to records as specified above in all his contracts and all tier subcontracts or change orders in excess of \$25,000 that are directly related to project performance.

C) Audits shall be consistent with generally accepted auditing standards in accordance with the American Institute of Public Accountants Professional Standards.

D) The Contractor shall agree to the disclosure of all information and reports resulting from access to records pursuant to subsection (A) above. Where the audit concerns the Contractor, the auditing agency shall afford the Contractor an opportunity for an audit exit conference and an opportunity to comment on the pertinent portions of the draft audit report. The final audit report shall include the written comments, if any, of the audited parties.

E) The records required by subsection (A) above shall be maintained and made available during performance of the work under this loan agreement and for three years after the date of final loan audit. In addition, records that relate to any dispute or litigation or the settlement of claims arising out of any performance, costs or items to which an audit exception has been taken, shall be maintained and made available for three years after resolution of such dispute, appeal, litigation, claim or exception.

- F) The right of access will generally be exercised with respect to financial records under:
- i) Negotiated prime Contractors;
  - ii) Negotiated change orders or contract amendments in excess of \$25,000 affecting the price of any formally advertised, competitively awarded, fixed price contract; and
  - iii) Subcontracts or purchase orders under any contract other than a formally advertised, competitively awarded, fixed price contract.
- G) The right of access will generally not be exercised with respect to a prime contract, subcontract, or purchase order awarded after effective price competition. In any event, the right of access shall be exercised under any type of contract or subcontract:
- i) With respect to records pertaining directly to contract performance, excluding any financial records of the Contractor; and;
  - ii) If there is any indication that fraud, gross abuse, or corrupt practices may be involved in the award or performance of the contract or subcontract.

#### 11. Covenant Against Contingent Fees

The Contractor shall warrant that no person or selling agency has been employed or retained to solicit or secure the contract upon an agreement or understanding for a commission, percentage, brokerage, or contingent fee. For breach or violation of this warranty, the owner shall have the right to annul the contract without liability or in its discretion to deduct from the contract price or consideration, or otherwise recover, the full amount of such commission, percentage, brokerage, or contingent fee.

#### 12. Non-Discrimination

Non-Discrimination in Employment - The Contractor, in performing under this Contract, shall not discriminate against any worker, employee or applicant, or any member of the public because of race, creed, color, age, sex, physical or mental handicap unrelated to ability or national origin, or otherwise commit an unfair employment practice, and shall submit a Certification of Non-segregated Facilities with the Bid.

The bidder, his sub-Contractors, or labor organizations furnishing skilled or unskilled workers, craft union skilled labor, or anyone who may perform any labor or service, shall not commit within the State of Illinois, under this contract, any unfair employment practices as defined in the act of the 72nd General Assembly entitled "Fair Employment Practices Act". The Contractor is referred to Ill. Rev. Stat. (1961) ch. 48, paragraph 851 et seq. The Contractor further agrees that this article will be incorporated by the Contractor in all contracts entered into with suppliers of materials or services, contracts and subcontractors, and all labor organizations furnishing skilled, unskilled, and craft union skilled labor, or who may perform any such labor or services in connection with this contract.

The Contractor shall carry out all applicable requirements of 40 CFR Part 33 in the award and administration of contracts awarded under IEPA financial assistance agreements. Failure by the Contractor to carry out these requirements is a material breach of this Contract which may result in the termination of this Contract or other legally available remedies.

**OWNER COPY**

**CONTRACT**

Village: Village of Villa Park

By: Albert Beetham  
Village President

Attest:  
By: Jessica Kreschke  
Village Clerk



Contractor: Michels Hpe Services: a division of Michels Corporation  
(Name of Contractor)

By: [Signature] Regional Manager  
(Name of Owner or Officer), (Title or Office)

Attest:  
By: Shenette A. Zubrod, Business Oper. Manager  
(Name of Officer Attesting) (Title or Office)

*This page intentionally left blank.*





# CERTIFICATE OF LIABILITY INSURANCE

DATE (MM/DD/YYYY)  
12/13/2019

THIS CERTIFICATE IS ISSUED AS A MATTER OF INFORMATION ONLY AND CONFERS NO RIGHTS UPON THE CERTIFICATE HOLDER. THIS CERTIFICATE DOES NOT AFFIRMATIVELY OR NEGATIVELY AMEND, EXTEND OR ALTER THE COVERAGE AFFORDED BY THE POLICIES BELOW. THIS CERTIFICATE OF INSURANCE DOES NOT CONSTITUTE A CONTRACT BETWEEN THE ISSUING INSURER(S), AUTHORIZED REPRESENTATIVE OR PRODUCER, AND THE CERTIFICATE HOLDER.

IMPORTANT: If the certificate holder is an ADDITIONAL INSURED, the policy(ies) must have ADDITIONAL INSURED provisions or be endorsed. If SUBROGATION IS WAIVED, subject to the terms and conditions of the policy, certain policies may require an endorsement. A statement on this certificate does not confer rights to the certificate holder in lieu of such endorsement(s).

PRODUCER  
Willis Towers Watson Midwest, Inc.  
c/o 26 Century Blvd  
P.O. Box 305191  
Nashville, TN 372305191 USA

CONTACT NAME: Willis Towers Watson Certificate Center  
PHONE (A/C, No, Ext): 1-877-945-7378 FAX (A/C, No): 1-888-467-2378  
E-MAIL ADDRESS: certificates@willis.com

RECEIVED  
DEC 13 2019  
Village of Villa Park  
Dept. of Public Works

INSURED  
Michels Corporation  
817 Main Street  
P.O. Box 128  
Brownsville, WI 53006

INSURER(S) AFFORDING COVERAGE	NAIC #
INSURER A: Greenwich Insurance Company	22322
INSURER B: XL Insurance America Inc	24554
INSURER C: XL Specialty Insurance Company	37885
INSURER D:	
INSURER E:	
INSURER F:	

COVERAGES CERTIFICATE NUMBER: W14243944 REVISION NUMBER:

THIS IS TO CERTIFY THAT THE POLICIES OF INSURANCE LISTED BELOW HAVE BEEN ISSUED TO THE INSURED NAMED ABOVE FOR THE POLICY PERIOD INDICATED. NOTWITHSTANDING ANY REQUIREMENT, TERM OR CONDITION OF ANY CONTRACT OR OTHER DOCUMENT WITH RESPECT TO WHICH THIS CERTIFICATE MAY BE ISSUED OR MAY PERTAIN, THE INSURANCE AFFORDED BY THE POLICIES DESCRIBED HEREIN IS SUBJECT TO ALL THE TERMS, EXCLUSIONS AND CONDITIONS OF SUCH POLICIES. LIMITS SHOWN MAY HAVE BEEN REDUCED BY PAID CLAIMS.

INSR LTR	TYPE OF INSURANCE	ADDL INSD	SUBR WVD	POLICY NUMBER	POLICY EFF (MM/DD/YYYY)	POLICY EXP (MM/DD/YYYY)	LIMITS
A	<input checked="" type="checkbox"/> COMMERCIAL GENERAL LIABILITY <input type="checkbox"/> CLAIMS-MADE <input checked="" type="checkbox"/> OCCUR	Y	Y	CGD740955302	02/01/2019	02/01/2020	EACH OCCURRENCE \$ 3,000,000 DAMAGE TO RENTED PREMISES (Ea occurrence) \$ 1,000,000 MED EXP (Any one person) \$ PERSONAL & ADV INJURY \$ 3,000,000 GENERAL AGGREGATE \$ 6,000,000 PRODUCTS - COMP/OP AGG \$ 6,000,000
A	AUTOMOBILE LIABILITY <input checked="" type="checkbox"/> ANY AUTO OWNED AUTOS ONLY <input type="checkbox"/> HIRED AUTOS ONLY <input type="checkbox"/> SCHEDULED AUTOS NON-OWNED AUTOS ONLY	Y		CAD740955402	02/01/2019	02/01/2020	COMBINED SINGLE LIMIT (Ea accident) \$ 3,000,000 BODILY INJURY (Per person) \$ BODILY INJURY (Per accident) \$ PROPERTY DAMAGE (Per accident) \$
B	<input checked="" type="checkbox"/> UMBRELLA LIAB <input checked="" type="checkbox"/> OCCUR <input checked="" type="checkbox"/> EXCESS LIAB <input type="checkbox"/> CLAIMS-MADE	Y	Y	US00077661LI19A	02/01/2019	02/01/2020	EACH OCCURRENCE \$ 5,000,000 AGGREGATE \$ 5,000,000
C	WORKERS COMPENSATION AND EMPLOYERS' LIABILITY ANY PROPRIETOR/PARTNER/EXECUTIVE OFFICER/MEMBER EXCLUDED? (Mandatory in NH) If yes, describe under DESCRIPTION OF OPERATIONS below	N/A	Y	CWD740955102	02/01/2019	02/01/2020	<input checked="" type="checkbox"/> PER STATUTE <input type="checkbox"/> OTHER E.L. EACH ACCIDENT \$ 1,000,000 E.L. DISEASE - EA EMPLOYEE \$ 1,000,000 E.L. DISEASE - POLICY LIMIT \$ 1,000,000
C	Workers Compensation - WI and Employers Liability Work Comp: Per Statute		Y	CWR740955202	02/01/2019	02/01/2020	E.L. Each Accident \$1,000,000 E.L. Disease-Each Emp \$1,000,000 E.L. Disease-Pol Lmt \$1,000,000

DESCRIPTION OF OPERATIONS / LOCATIONS / VEHICLES (ACORD 101, Additional Remarks Schedule, may be attached if more space is required)  
This voids and replaces previously issued certificate dated 12/06/2019 WITH ID: W14114623.

Re: 2019 Sewer Rehabilitation Program.

Village of Villa Park, Member, its officials, agents, employees and volunteers are Additional Insureds with respect to the General Liability, Automobile Liability and Umbrella/Excess Liability coverage and the work performed by the Named

### CERTIFICATE HOLDER

Village of Villa Park  
20 South Ardmore Ave  
Villa Park, IL 60181

### CANCELLATION

SHOULD ANY OF THE ABOVE DESCRIBED POLICIES BE CANCELLED BEFORE THE EXPIRATION DATE THEREOF, NOTICE WILL BE DELIVERED IN ACCORDANCE WITH THE POLICY PROVISIONS.  
AUTHORIZED REPRESENTATIVE  
*[Signature]*



AGENCY CUSTOMER ID: \_\_\_\_\_

LOC #: \_\_\_\_\_



## ADDITIONAL REMARKS SCHEDULE

Page 2 of 2

AGENCY Willis Towers Watson Midwest, Inc.		NAMED INSURED Michels Corporation 817 Main Street P.O. Box 128 Brownsville, WI 53006	
POLICY NUMBER See Page 1		EFFECTIVE DATE: See Page 1	
CARRIER See Page 1	NAIC CODE See Page 1		

### ADDITIONAL REMARKS

THIS ADDITIONAL REMARKS FORM IS A SCHEDULE TO ACORD FORM,  
FORM NUMBER: 25 FORM TITLE: Certificate of Liability Insurance

Insured when required by written contract, agreement or permit executed prior to loss.

Such insurance as is afforded to Additional Insureds shall be Primary and Non-contributory with any other insurance available to Additional Insureds if required by contract executed prior to loss.

Waiver of Subrogation applies in favor of Additional Insureds with respects to General Liability, Umbrella/Excess Liability and Workers Compensation as permitted by law.



**ENDORSEMENT #**

This endorsement, effective 12:01 a.m., 02/01/2019, forms a part of Policy No. CGD740955302 issued to M10, INC. by Greenwich Insurance Company.

THIS ENDORSEMENT CHANGES THE POLICY. PLEASE READ IT CAREFULLY.

**ADDITIONAL INSURED – OWNERS, LESSEES OR CONTRACTORS – SCHEDULED PERSON OR ORGANIZATION**

This endorsement modifies insurance provided under the following:

COMMERCIAL GENERAL LIABILITY COVERAGE FORM

**SCHEDULE**

<b>Name Of Additional Insured Person(s) Or Organization(s):</b>	<b>Location(s) Of Covered Operations</b>
Any person or organization that you are required in a written contract or written agreement to include as an additional insured provided the "bodily injury" or "property damage" occurs subsequent to the execution of the written contract or written agreement.	Various as required per written contract.
Information required to complete this Schedule, if not shown above, will be shown in the Declarations.	

**A. Section II – Who Is An Insured** is amended to include as an additional insured the person(s) or organization(s) shown in the Schedule, but only with respect to liability for "bodily injury", "property damage" or "personal and advertising injury" caused, in whole or in part, by:

1. Your acts or omissions; or
2. The acts or omissions of those acting on your behalf;

in the performance of your ongoing operations for the additional insured(s) at the location(s) designated above.

**B.** With respect to the insurance afforded to these additional insureds, the following additional exclusions apply:

This insurance does not apply to "bodily injury" or "property damage" occurring after:

1. All work, including materials, parts or equipment furnished in connection with such work, on the project (other than service, maintenance or repairs) to be performed by or on behalf of the additional insured(s) at the location of the covered operations has been completed; or
2. That portion of "your work" out of which the injury or damage arises has been put to its intended use by any person or organization other than another contractor or subcontractor engaged in performing operations for a principal as a part of the same project.



All other terms and conditions of this policy remain unchanged.



**ENDORSEMENT #**

This endorsement, effective 12:01 a.m., 02/01/2019, forms a part of Policy No.

CGD740955302 issued to M10, INC. by Greenwich Insurance Company.

THIS ENDORSEMENT CHANGES THE POLICY. PLEASE READ IT CAREFULLY.

**ADDITIONAL INSURED – OWNERS, LESSEES OR CONTRACTORS – COMPLETED OPERATIONS**

This endorsement modifies insurance provided under the following:

COMMERCIAL GENERAL LIABILITY COVERAGE FORM

**SCHEDULE**

<b>Name Of Additional Insured Person(s) Or Organization(s):</b>	<b>Location And Description Of Completed Operations</b>
Any person or organization that you are required in a written contract or written agreement to include as an additional insured provided the "bodily injury" or "property damage" occurs subsequent to the execution of the written contract or written agreement.	Various as required per written contract.
Information required to complete this Schedule, if not shown above, will be shown in the Declarations.	

**Section II – Who Is An Insured** is amended to include as an additional insured the person(s) or organization(s) shown in the Schedule, but only with respect to liability for "bodily injury" or "property damage" caused, in whole or in part, by "your work" at the location designated and described in the schedule of this endorsement performed for that additional insured and included in the "products-completed operations hazard".

All other terms and conditions of this policy remain unchanged.



**ENDORSEMENT #**

This endorsement, effective 12:01 a.m., February 1, 2019, forms a part of Policy No. CGD740955302 issued to M10, INC. by Greenwich Insurance Company.

THIS ENDORSEMENT CHANGES THE POLICY. PLEASE READ IT CAREFULLY.

**CANCELLATION NOTIFICATION TO OTHERS ENDORSEMENT**

In the event coverage is cancelled for any statutorily permitted reason, other than nonpayment of premium, advanced written notice will be mailed or delivered to person(s) or entity(ies) according to the notification schedule shown below:

Name of Person(s) or Entity(ies)	Mailing Address:	Number of Days Advanced Notice of Cancellation:
As per schedule on file with company		30

All other terms and conditions of the Policy remain unchanged.



**ENDORSEMENT #**

This endorsement, effective 12:01 a.m., February 1, 2019, forms a part of Policy No.CAD740955402 issued to M10, INC. by Greenwich Insurance Company.

THIS ENDORSEMENT CHANGES THE POLICY. PLEASE READ IT CAREFULLY.

**CANCELLATION NOTIFICATION TO OTHERS ENDORSEMENT**

In the event coverage is cancelled for any statutorily permitted reason, other than nonpayment of premium, advanced written notice will be mailed or delivered to person(s) or entity(ies) according to the notification schedule shown below:

Name of Person(s) or Entity(ies)	Mailing Address:	Number of Days Advanced Notice of Cancellation:
As per schedule on file with company		30

All other terms and conditions of the Policy remain unchanged.



**ENDORSEMENT #**

This endorsement, effective 12:01 a.m., February 1, 2019 forms a part of Policy No. CWD740955102 issued to M10, INC. by XL Specialty Insurance Company.

THIS ENDORSEMENT CHANGES THE POLICY. PLEASE READ IT CAREFULLY.

**CANCELLATION NOTIFICATION TO OTHERS ENDORSEMENT**

This endorsement modifies insurance provided under the following:

WORKERS' COMPENSATION AND EMPLOYERS' LIABILITY INSURANCE POLICY

In the event coverage is cancelled for any statutorily permitted reason, other than nonpayment of premium, advanced written notice will be mailed or delivered to person(s) or entity(ies) according to the notification schedule shown below:

Name of Person(s) or Entity(ies)	Mailing Address:	Number of Days Advanced Notice of Cancellation:
As per schedule on file with company		30

All other terms and conditions of the Policy remain unchanged.

This endorsement changes the policy to which it is attached and is effective on the date issued unless otherwise stated.

**(The information below is required only when this endorsement is issued subsequent to preparation of the policy.)**

Endorsement Effective February 1, 2019    Policy No. CWD740955102    Endorsement No.

Insured M10, INC.

Premium

Insurance Company  
XL Specialty Insurance Company

Countersigned by \_\_\_\_\_



**ENDORSEMENT #**

This endorsement, effective 12:01 a.m., February 1, 2019 forms a part of Policy No. CWR740955202 issued to M10, INC. by XL Specialty Insurance Company.

THIS ENDORSEMENT CHANGES THE POLICY. PLEASE READ IT CAREFULLY.

**CANCELLATION NOTIFICATION TO OTHERS ENDORSEMENT**

This endorsement modifies insurance provided under the following:

WORKERS' COMPENSATION AND EMPLOYERS' LIABILITY INSURANCE POLICY

In the event coverage is cancelled for any statutorily permitted reason, other than nonpayment of premium, advanced written notice will be mailed or delivered to person(s) or entity(ies) according to the notification schedule shown below:

Name of Person(s) or Entity(ies)	Mailing Address:	Number of Days Advanced Notice of Cancellation:
As per schedule on file with company		30

All other terms and conditions of the Policy remain unchanged.

This endorsement changes the policy to which it is attached and is effective on the date issued unless otherwise stated.

**(The information below is required only when this endorsement is issued subsequent to preparation of the policy.)**

Endorsement Effective February 1, 2019    Policy No. CWR740955202    Endorsement No.

Insured M10, INC.    Premium

Insurance Company  
XL Specialty Insurance Company

Countersigned by \_\_\_\_\_



**PERFORMANCE BOND**

Any singular reference to Contractor, Surety, Owner, or other party shall be considered plural where applicable.

**CONTRACTOR (Name and Address):**

Michels Corporation  
817 West Main Street  
Brownsville, WI 53006

**SURETY (Name, and Address of Principal Place of Business):**

Continental Casualty Company  
151 North Franklin Street  
Chicago, IL 60606  
AND  
Liberty Mutual Insurance Company  
175 Berkeley Street  
Boston, MA 02116

**OWNER (Name and Address):**

Village of Villa Park  
20 South Ardmore Avenue  
Villa Park, IL 60181

**CONTRACT**

**Effective Date of Agreement:**

Amount: \$1,156,040.70

Description (Name and Location): 2019 Sewer Rehabilitation Program

**BOND**

Bond Number: 30084428/190043710

Date (Not earlier than Effective Date of Agreement):

Amount: \$1,156,040.70

Modifications to this Bond Form: NONE

Surety and Contractor, intending to be legally bound hereby, subject to the terms set forth below, do each cause this Performance Bond to be duly executed by an authorized officer, agent, or representative.

**CONTRACTOR AS PRINCIPAL**

Michels Corporation

Contractor's Name and Corporate Seal



Continental Casualty Company &  
Liberty Mutual Insurance Company

(Seal)

Surety's Name and Corporate Seal

By:

*[Signature]*  
Signature

*[Signature]*  
Signature (Attach Power of Attorney)

Mike Figlio  
Print Name

Heather R. Goedtel  
Print Name

Regional Manager, Pipe Services  
Title

Attorney-in-Fact  
Title

Attest:

*[Signature]*  
Signature

Attest:

*[Signature]*  
Signature

Admin Assistant Pipe Services  
Title

Witness  
Title

Note: Provide execution by additional parties, such as joint venturers, if necessary.

Contractor and Surety, jointly and severally, bind themselves, their heirs, executors, administrators, successors, and assigns to Owner for the performance of the Contract, which is incorporated herein by reference.

1. If Contractor performs the Contract, Surety and Contractor have no obligation under this Bond, except to participate in conferences as provided in Paragraph 2.1.

2. If there is no Owner Default, Surety's obligation under this Bond shall arise after:

2.1 Owner has notified Contractor and Surety, at the addresses described in Paragraph 9 below, that Owner is considering declaring a Contractor Default and has requested and attempted to arrange a conference with Contractor and Surety to be held not later than 15 days after receipt of such notice to discuss methods of performing the Contract. If Owner, Contractor, and Surety agree, Contractor shall be allowed a reasonable time to perform the Contract, but such an agreement shall not waive Owner's right, if any, subsequently to declare a Contractor Default; and

2.2 Owner has declared a Contractor Default and formally terminated Contractor's right to complete the Contract. Such Contractor Default shall not be declared earlier than 20 days after Contractor and Surety have received notice as provided in Paragraph 2.1; and

2.3 Owner has agreed to pay the Balance of the Contract Price to:

1. Surety in accordance with the terms of the Contract; or
2. Another contractor selected pursuant to Paragraph 3.3 to perform the Contract.

3. When Owner has satisfied the conditions of Paragraph 2, Surety shall promptly, and at Surety's expense, take one of the following actions:

3.1 Arrange for Contractor, with consent of Owner, to perform and complete the Contract; or

3.2 Undertake to perform and complete the Contract itself, through its agents or through independent contractors; or

3.3 Obtain bids or negotiated proposals from qualified contractors acceptable to Owner for a contract for performance and completion of the Contract, arrange for a contract to be prepared for execution by Owner and contractor selected with Owner's concurrence, to be secured with performance and payment bonds executed by a qualified surety equivalent to the bonds issued on the Contract, and pay to Owner the amount of damages as described in Paragraph 5 in excess of the Balance of the Contract Price incurred by Owner resulting from Contractor Default; or

3.4 Waive its right to perform and complete, arrange for completion, or obtain a new contractor, and with reasonable promptness under the circumstances:

1. After investigation, determine the amount for which it may be liable to Owner and, as soon as practicable after the amount is determined, tender payment therefor to Owner; or
2. Deny liability in whole or in part and notify Owner citing reasons therefor.

4. If Surety does not proceed as provided in Paragraph 3 with reasonable promptness, Surety shall be deemed to be in default on this Bond 15 days after receipt of an additional written notice from Owner to Surety demanding that Surety perform its obligations under this Bond, and Owner shall be entitled to enforce any remedy available to Owner. If Surety proceeds as provided in Paragraph 3.4, and Owner refuses the payment tendered or Surety has denied liability, in whole or in part, without further notice Owner shall be entitled to enforce any remedy available to Owner.

5. After Owner has terminated Contractor's right to complete the Contract, and if Surety elects to act under Paragraph 3.1, 3.2, or 3.3 above, then the responsibilities of Surety to Owner shall not be greater than those of Contractor under the Contract, and the responsibilities of Owner to Surety shall not be greater than those of Owner under the Contract. To the limit of the amount of this Bond, but subject to commitment by Owner of the Balance of the Contract Price to mitigation of costs and damages on the Contract, Surety is obligated without duplication for:

- 5.1 The responsibilities of Contractor for correction of defective Work and completion of the Contract;
- 5.2 Additional legal, design professional, and delay costs resulting from Contractor's Default, and resulting from the actions of or failure to act of Surety under Paragraph 3; and
- 5.3 Liquidated damages, or if no liquidated damages are specified in the Contract, actual damages caused by delayed performance or non-performance of Contractor.

6. Surety shall not be liable to Owner or others for obligations of Contractor that are unrelated to the Contract, and the Balance of the Contract Price shall not be reduced or set off on account of any such unrelated obligations. No right of action shall accrue on this Bond to any person or entity other than Owner or its heirs, executors, administrators, or successors.

7. Surety hereby waives notice of any change, including changes of time, to Contract or to related subcontracts, purchase orders, and other obligations.

8. Any proceeding, legal or equitable, under this Bond may be instituted in any court of competent jurisdiction in the location in which the Work or part of the Work is located, and shall be instituted within two years after Contractor Default or within two years after Contractor ceased working or within two years after Surety refuses or fails to perform its obligations under this Bond, whichever occurs first. If the provisions of this paragraph are void or prohibited by law, the minimum period of limitation available to sureties as a defense in the jurisdiction of the suit shall be applicable.

9. Notice to Surety, Owner, or Contractor shall be mailed or delivered to the address shown on the signature page.

10. When this Bond has been furnished to comply with a statutory requirement in the location where the Contract was to be performed, any provision in this Bond conflicting with said statutory requirement shall be deemed deleted herefrom and provisions conforming to such statutory requirement shall be deemed incorporated herein. The intent is that this Bond shall be construed as a statutory bond and not as a common law bond.

11. Definitions.

- 11.1 Balance of the Contract Price: The total amount payable by Owner to Contractor under the Contract after all proper adjustments have been made, including allowance to Contractor of any amounts received or to be received by Owner in settlement of insurance or other Claims for damages to which Contractor is entitled, reduced by all valid and proper payments made to or on behalf of Contractor under the Contract.
- 11.2 Contract: The agreement between Owner and Contractor identified on the signature page, including all Contract Documents and changes thereto.
- 11.3 Contractor Default: Failure of Contractor, which has neither been remedied nor waived, to perform or otherwise to comply with the terms of the Contract.
- 11.4 Owner Default: Failure of Owner, which has neither been remedied nor waived, to pay Contractor as required by the Contract or to perform and complete or otherwise comply with the other terms thereof.

FOR INFORMATION ONLY - *(Name, Address and Telephone)*

Surety Agency or Broker:

Owner's Representative *(Engineer or other party)*:

Willis Towers Watson Midwest, Inc.  
8400 Normandale Lake Blvd., Suite 1700  
Bloomington, MN 55437  
Phone: 763-302-7159

***This page intentionally left blank.***

UNIVERSITY OF CALIFORNIA  
LIBRARY  
DIVERSITY  
SERVICES  
UNIVERSITY OF CALIFORNIA  
LIBRARY  
DIVERSITY  
SERVICES

**PAYMENT BOND**

Any singular reference to Contractor, Surety, Owner, or other party shall be considered plural where applicable.

**CONTRACTOR (Name and Address):**

Michels Corporation  
817 West Main Street  
Brownsville, WI 53006

**OWNER (Name and Address):**

Village of Villa Park  
20 South Ardmore Avenue  
Villa Park, IL 60181

**CONTRACT**

**Effective Date of Agreement:**

**Amount:** \$1,156,040.70

**Description (Name and Location):** 2019 Sewer Rehabilitation Program

**SURETY (Name, and Address of Principal Place of Business):**

Continental Casualty Company  
151 North Franklin Street  
Chicago, IL 60606  
AND  
Liberty Mutual Insurance Company  
175 Berkeley Street  
Boston, MA 02116

**BOND**

**Bond Number:** 30084428/190043710

**Date (Not earlier than Effective Date of Agreement):**

**Amount:** \$1,156,040.70

**Modifications to this Bond Form:** NONE

Surety and Contractor, intending to be legally bound hereby, subject to the terms set forth below, do each cause this Payment Bond to be duly executed by an authorized officer, agent, or representative.

**CONTRACTOR AS PRINCIPAL**

Michels Corporation

Contractor's Name and Corporate Seal

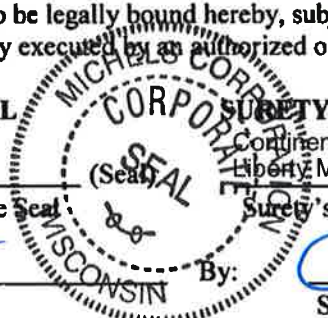

**SURETY**

Continental Casualty Company & Liberty Mutual Insurance Company

Surety's Name and Corporate Seal

(Seal)

By:

*[Signature]*  
Signature

By:

*[Signature]*  
Signature (Attach Power of Attorney)

*Mike Figlio*  
Print Name

Heather R. Goedel  
Print Name

*Regional Manager Pipe Services*  
Title

Attorney-in-Fact  
Title

Attest:

*[Signature]*  
Signature

Attest:

*[Signature]*  
Signature

*Admin Assistant Pipe Services*  
Title

Witness  
Title

Note: Provide execution by additional parties, such as joint venturers, if necessary.

1. Contractor and Surety, jointly and severally, bind themselves, their heirs, executors, administrators, successors, and assigns to Owner to pay for labor, materials, and equipment furnished by Claimants for use in the performance of the Contract, which is incorporated herein by reference.
2. With respect to Owner, this obligation shall be null and void if Contractor:
  - 2.1 Promptly makes payment, directly or indirectly, for all sums due Claimants, and
  - 2.2 Defends, indemnifies, and holds harmless Owner from all claims, demands, liens, or suits alleging non-payment by Contractor by any person or entity who furnished labor, materials, or equipment for use in the performance of the Contract, provided Owner has promptly notified Contractor and Surety (at the addresses described in Paragraph 12) of any claims, demands, liens, or suits and tendered defense of such claims, demands, liens, or suits to Contractor and Surety, and provided there is no Owner Default.
3. With respect to Claimants, this obligation shall be null and void if Contractor promptly makes payment, directly or indirectly, for all sums due.
4. Surety shall have no obligation to Claimants under this Bond until:
  - 4.1 Claimants who are employed by or have a direct contract with Contractor have given notice to Surety (at the address described in Paragraph 12) and sent a copy, or notice thereof, to Owner, stating that a claim is being made under this Bond and, with substantial accuracy, the amount of the claim.
  - 4.2 Claimants who do not have a direct contract with Contractor:
    1. Have furnished written notice to Contractor and sent a copy, or notice thereof, to Owner, within 90 days after having last performed labor or last furnished materials or equipment included in the claim stating, with substantial accuracy, the amount of the claim and the name of the party to whom the materials or equipment were furnished or supplied, or for whom the labor was done or performed; and
    2. Have either received a rejection in whole or in part from Contractor, or not received within 30 days of furnishing the above notice any communication from Contractor by which Contractor had indicated the claim will be paid directly or indirectly; and
    3. Not having been paid within the above 30 days, have sent a written notice to Surety (at the address described in Paragraph 12) and sent a copy, or notice thereof, to Owner, stating that a claim is being made under this Bond and enclosing a copy of the previous written notice furnished to Contractor.
5. If a notice by a Claimant required by Paragraph 4 is provided by Owner to Contractor or to Surety, that is sufficient compliance.
6. When a Claimant has satisfied the conditions of Paragraph 4, the Surety shall promptly and at Surety's expense take the following actions:
  - 6.1 Send an answer to that Claimant, with a copy to Owner, within 45 days after receipt of the claim, stating the amounts that are undisputed and the basis for challenging any amounts that are disputed.
  - 6.2 Pay or arrange for payment of any undisputed amounts.
7. Surety's total obligation shall not exceed the amount of this Bond, and the amount of this Bond shall be credited for any payments made in good faith by Surety.
8. Amounts owed by Owner to Contractor under the Contract shall be used for the performance of the Contract and to satisfy claims, if any, under any performance bond. By Contractor furnishing and Owner accepting this Bond, they agree that all funds earned by Contractor in the performance of the Contract are dedicated to satisfy obligations of Contractor and Surety under this Bond, subject to Owner's priority to use the funds for the completion of the Work.

9. Surety shall not be liable to Owner, Claimants, or others for obligations of Contractor that are unrelated to the Contract. Owner shall not be liable for payment of any costs or expenses of any Claimant under this Bond, and shall have under this Bond no obligations to make payments to, give notices on behalf of, or otherwise have obligations to Claimants under this Bond.

10. Surety hereby waives notice of any change, including changes of time, to the Contract or to related subcontracts, purchase orders, and other obligations.

11. No suit or action shall be commenced by a Claimant under this Bond other than in a court of competent jurisdiction in the location in which the Work or part of the Work is located or after the expiration of one year from the date (1) on which the Claimant gave the notice required by Paragraph 4.1 or Paragraph 4.2.3, or (2) on which the last labor or service was performed by anyone or the last materials or equipment were furnished by anyone under the Contract, whichever of (1) or (2) first occurs. If the provisions of this paragraph are void or prohibited by law, the minimum period of limitation available to sureties as a defense in the jurisdiction of the suit shall be applicable.

12. Notice to Surety, Owner, or Contractor shall be mailed or delivered to the addresses shown on the signature page. Actual receipt of notice by Surety, Owner, or Contractor, however accomplished, shall be sufficient compliance as of the date received at the address shown on the signature page.

13. When this Bond has been furnished to comply with a statutory requirement in the location where the Contract was to be performed, any provision in this Bond conflicting with said statutory requirement shall be deemed deleted herefrom and provisions conforming to such statutory requirement shall be deemed incorporated herein. The intent is that this Bond shall be construed as a statutory Bond and not as a common law bond.

14. Upon request of any person or entity appearing to be a potential beneficiary of this Bond, Contractor shall promptly furnish a copy of this Bond or shall permit a copy to be made.

#### 15. Definitions

15.1 Claimant: An individual or entity having a direct contract with Contractor, or with a first-tier subcontractor of Contractor, to furnish labor, materials, or equipment for use in the performance of the Contract. The intent of this Bond shall be to include without limitation in the terms "labor, materials or equipment" that part of water, gas, power, light, heat, oil, gasoline, telephone service, or rental equipment used in the Contract, architectural and engineering services required for performance of the Work of Contractor and Contractor's subcontractors, and all other items for which a mechanic's lien may be asserted in the jurisdiction where the labor, materials, or equipment were furnished.

15.2 Contract: The agreement between Owner and Contractor identified on the signature page, including all Contract Documents and changes thereto.

15.3 Owner Default: Failure of Owner, which has neither been remedied nor waived, to pay Contractor as required by the Contract, or to perform and complete or otherwise comply with the other terms thereof.

**FOR INFORMATION ONLY – (Name, Address, and Telephone)**

**Surety Agency or Broker:**

**Owner's Representative (Engineer or other):**

Willis Towers Watson Midwest, Inc.  
8400 Normandale Lake Blvd., Suite 1700  
Bloomington, MN 55437  
Phone: 763-302-7159

***This page intentionally left blank.***





**POWER OF ATTORNEY APPOINTING INDIVIDUAL ATTORNEY-IN-FACT**

Know All Men By These Presents, That Continental Casualty Company, an Illinois insurance company, National Fire Insurance Company of Hartford, an Illinois insurance company, and American Casualty Company of Reading, Pennsylvania, a Pennsylvania insurance company (herein called "the CNA Companies"), are duly organized and existing insurance companies having their principal offices in the City of Chicago, and State of Illinois, and that they do by virtue of the signatures and seals herein affixed hereby make, constitute and appoint

**Brian D. Carpenter, Jessica Hoff, Nicole Langer, Craig Olmstead, Trisha Kasper, Blake S. Bohlig, Kelly Nicole Bruggeman, Heather R. Goedel, Michelle Halter, Individually**

of Bloomington, MN, their true and lawful Attorney(s)-in-Fact with full power and authority hereby conferred to sign, seal and execute for and on their behalf bonds, undertakings and other obligatory instruments of similar nature

**- In Unlimited Amounts -**

and to bind them thereby as fully and to the same extent as if such instruments were signed by a duly authorized officer of their insurance companies and all the acts of said Attorney, pursuant to the authority hereby given is hereby ratified and confirmed.

This Power of Attorney is made and executed pursuant to and by authority of the By-Law and Resolutions, printed on the reverse hereof, duly adopted, as indicated, by the Boards of Directors of the insurance companies.

In Witness Whereof, the CNA Companies have caused these presents to be signed by their Vice President and their corporate seals to be hereto affixed on this 22nd day of February, 2019.



Continental Casualty Company  
National Fire Insurance Company of Hartford  
American Casualty Company of Reading, Pennsylvania

*Paul T. Bruflat*  
Paul T. Bruflat Vice President

State of South Dakota, County of Minnehaha, ss:

On this 22nd day of February, 2019, before me personally came Paul T. Bruflat to me known, who, being by me duly sworn, did depose and say: that he resides in the City of Sioux Falls, State of South Dakota; that he is a Vice President of Continental Casualty Company, an Illinois insurance company, National Fire Insurance Company of Hartford, an Illinois insurance company, and American Casualty Company of Reading, Pennsylvania, a Pennsylvania insurance company described in and which executed the above instrument; that he knows the seals of said insurance companies; that the seals affixed to the said instrument are such corporate seals; that they were so affixed pursuant to authority given by the Boards of Directors of said insurance companies and that he signed his name thereto pursuant to like authority, and acknowledges same to be the act and deed of said insurance companies.



My Commission Expires June 23, 2021

*J. Mohr*  
J. Mohr Notary Public

**CERTIFICATE**

I, D. Johnson, Assistant Secretary of Continental Casualty Company, an Illinois insurance company, National Fire Insurance Company of Hartford, an Illinois insurance company, and American Casualty Company of Reading, Pennsylvania, a Pennsylvania insurance company do hereby certify that the Power of Attorney herein above set forth is still in force, and further certify that the By-Law and Resolution of the Board of Directors of the insurance companies printed on the reverse hereof is still in force. In testimony whereof I have hereunto subscribed my name and affixed the seal of the said insurance companies this \_\_\_\_\_ day of \_\_\_\_\_.



Continental Casualty Company  
National Fire Insurance Company of Hartford  
American Casualty Company of Reading, Pennsylvania

*D. Johnson*  
D. Johnson Assistant Secretary

Form F6853-4/2012

## Authorizing By-Laws and Resolutions

ADOPTED BY THE BOARD OF DIRECTORS OF CONTINENTAL CASUALTY COMPANY:

This Power of Attorney is made and executed pursuant to and by authority of the following resolution duly adopted by the Board of Directors of the Company at a meeting held on May 12, 1995:

“RESOLVED: That any Senior or Group Vice President may authorize an officer to sign specific documents, agreements and instruments on behalf of the Company provided that the name of such authorized officer and a description of the documents, agreements or instruments that such officer may sign will be provided in writing by the Senior or Group Vice President to the Secretary of the Company prior to such execution becoming effective.”

This Power of Attorney is signed by Paul T. Bruflat, Vice President, who has been authorized pursuant to the above resolution to execute power of attorneys on behalf of Continental Casualty Company.

This Power of Attorney is signed and sealed by facsimile under and by the authority of the following Resolution adopted by the Board of Directors of the Company by unanimous written consent dated the 25<sup>th</sup> day of April, 2012:

“Whereas, the bylaws of the Company or specific resolution of the Board of Directors has authorized various officers (the “Authorized Officers”) to execute various policies, bonds, undertakings and other obligatory instruments of like nature; and

Whereas, from time to time, the signature of the Authorized Officers, in addition to being provided in original, hard copy format, may be provided via facsimile or otherwise in an electronic format (collectively, “Electronic Signatures”); Now therefore be it resolved: that the Electronic Signature of any Authorized Officer shall be valid and binding on the Company.”

ADOPTED BY THE BOARD OF DIRECTORS OF NATIONAL FIRE INSURANCE COMPANY OF HARTFORD:

This Power of Attorney is made and executed pursuant to and by authority of the following resolution duly adopted by the Board of Directors of the Company by unanimous written consent dated May 10, 1995:

“RESOLVED: That any Senior or Group Vice President may authorize an officer to sign specific documents, agreements and instruments on behalf of the Company provided that the name of such authorized officer and a description of the documents, agreements or instruments that such officer may sign will be provided in writing by the Senior or Group Vice President to the Secretary of the Company prior to such execution becoming effective.”

This Power of Attorney is signed by Paul T. Bruflat, Vice President, who has been authorized pursuant to the above resolution to execute power of attorneys on behalf of National fire Insurance Company of Hartford.

This Power of Attorney is signed and sealed by facsimile under and by the authority of the following Resolution adopted by the Board of Directors of the Company by unanimous written consent dated the 25<sup>th</sup> day of April, 2012:

“Whereas, the bylaws of the Company or specific resolution of the Board of Directors has authorized various officers (the “Authorized Officers”) to execute various policies, bonds, undertakings and other obligatory instruments of like nature; and

Whereas, from time to time, the signature of the Authorized Officers, in addition to being provided in original, hard copy format, may be provided via facsimile or otherwise in an electronic format (collectively, “Electronic Signatures”); Now therefore be it resolved: that the Electronic Signature of any Authorized Officer shall be valid and binding on the Company.”

ADOPTED BY THE BOARD OF DIRECTORS OF AMERICAN CASUALTY COMPANY OF READING, PENNSYLVANIA:

This Power of Attorney is made and executed pursuant to and by authority of the following resolution duly adopted by the Board of Directors of the Company by unanimous written consent dated May 10, 1995:

“RESOLVED: That any Senior or Group Vice President may authorize an officer to sign specific documents, agreements and instruments on behalf of the Company provided that the name of such authorized officer and a description of the documents, agreements or instruments that such officer may sign will be provided in writing by the Senior or Group Vice President to the Secretary of the Company prior to such execution becoming effective.”

This Power of Attorney is signed by Paul T. Bruflat, Vice President, who has been authorized pursuant to the above resolution to execute power of attorneys on behalf of American Casualty Company of Reading, Pennsylvania.

This Power of Attorney is signed and sealed by facsimile under and by the authority of the following Resolution adopted by the Board of Directors of the Company by unanimous written consent dated the 25<sup>th</sup> day of April, 2012:

“Whereas, the bylaws of the Company or specific resolution of the Board of Directors has authorized various officers (the “Authorized Officers”) to execute various policies, bonds, undertakings and other obligatory instruments of like nature; and

Whereas, from time to time, the signature of the Authorized Officers, in addition to being provided in original, hard copy format, may be provided via facsimile or otherwise in an electronic format (collectively, “Electronic Signatures”); Now therefore be it resolved: that the Electronic Signature of any Authorized Officer shall be valid and binding on the Company.”



This Power of Attorney limits the acts of those named herein, and they have no authority to bind the Company except in the manner and to the extent herein stated.

Liberty Mutual Insurance Company
The Ohio Casualty Insurance Company
West American Insurance Company

Certificate No: 8202635-190003

POWER OF ATTORNEY

KNOWN ALL PERSONS BY THESE PRESENTS: That The Ohio Casualty Insurance Company is a corporation duly organized under the laws of the State of New Hampshire, that Liberty Mutual Insurance Company is a corporation duly organized under the laws of the State of Massachusetts, and West American Insurance Company is a corporation duly organized under the laws of the State of Indiana (herein collectively called the "Companies"), pursuant to and by authority herein set forth, does hereby name, constitute and appoint, Blake S. Bohlig, Brian D. Carpenter, Kelly Nicole Enghausser, Heather R. Goedtel, Michelle Halter, Jessica Hoff, Nicole Langer, Craig Olmstead, Laurie Pflug

all of the city of Bloomington state of Minnesota each individually if there be more than one named, its true and lawful attorney-in-fact to make, execute, seal, acknowledge and deliver, for and on its behalf as surety and as its act and deed, any and all undertakings, bonds, recognizances and other surety obligations, in pursuance of these presents and shall be as binding upon the Companies as if they have been duly signed by the president and attested by the secretary of the Companies in their own proper persons.

IN WITNESS WHEREOF, this Power of Attorney has been subscribed by an authorized officer or official of the Companies and the corporate seals of the Companies have been affixed thereto this 21st day of November, 2019.



Liberty Mutual Insurance Company
The Ohio Casualty Insurance Company
West American Insurance Company

By: David M. Carey, Assistant Secretary

State of PENNSYLVANIA ss
County of MONTGOMERY

On this 21st day of November, 2019 before me personally appeared David M. Carey, who acknowledged himself to be the Assistant Secretary of Liberty Mutual Insurance Company, The Ohio Casualty Company, and West American Insurance Company, and that he, as such, being authorized so to do, execute the foregoing instrument for the purposes therein contained by signing on behalf of the corporations by himself as a duly authorized officer.

IN WITNESS WHEREOF, I have hereunto subscribed my name and affixed my notarial seal at King of Prussia, Pennsylvania, on the day and year first above written.



COMMONWEALTH OF PENNSYLVANIA
Notarial Seal
Teresa Pastella, Notary Public
Upper Merion Twp., Montgomery County
My Commission Expires March 28, 2021
Member, Pennsylvania Association of Notaries

By: Teresa Pastella, Notary Public

This Power of Attorney is made and executed pursuant to and by authority of the following By-laws and Authorizations of The Ohio Casualty Insurance Company, Liberty Mutual Insurance Company, and West American Insurance Company which resolutions are now in full force and effect reading as follows:

ARTICLE IV - OFFICERS: Section 12. Power of Attorney.
Any officer or other official of the Corporation authorized for that purpose in writing by the Chairman or the President, and subject to such limitation as the Chairman or the President may prescribe, shall appoint such attorneys-in-fact, as may be necessary to act in behalf of the Corporation to make, execute, seal, acknowledge and deliver as surety any and all undertakings, bonds, recognizances and other surety obligations. Such attorneys-in-fact, subject to the limitations set forth in their respective powers of attorney, shall have full power to bind the Corporation by their signature and execution of any such instruments and to attach thereto the seal of the Corporation. When so executed, such instruments shall be as binding as if signed by the President and attested to by the Secretary. Any power or authority granted to any representative or attorney-in-fact under the provisions of this article may be revoked at any time by the Board, the Chairman, the President or by the officer or officers granting such power or authority.

ARTICLE XIII - Execution of Contracts: Section 5. Surety Bonds and Undertakings.
Any officer of the Company authorized for that purpose in writing by the chairman or the president, and subject to such limitations as the chairman or the president may prescribe, shall appoint such attorneys-in-fact, as may be necessary to act in behalf of the Company to make, execute, seal, acknowledge and deliver as surety any and all undertakings, bonds, recognizances and other surety obligations. Such attorneys-in-fact subject to the limitations set forth in their respective powers of attorney, shall have full power to bind the Company by their signature and execution of any such instruments and to attach thereto the seal of the Company. When so executed such instruments shall be as binding as if signed by the president and attested by the secretary.

Certificate of Designation - The President of the Company, acting pursuant to the Bylaws of the Company, authorizes David M. Carey, Assistant Secretary to appoint such attorneys-in-fact as may be necessary to act on behalf of the Company to make, execute, seal, acknowledge and deliver as surety any and all undertakings, bonds, recognizances and other surety obligations.

Authorization - By unanimous consent of the Company's Board of Directors, the Company consents that facsimile or mechanically reproduced signature of any assistant secretary of the Company, wherever appearing upon a certified copy of any power of attorney issued by the Company in connection with surety bonds, shall be valid and binding upon the Company with the same force and effect as though manually affixed.

I, Renee C. Llewellyn, the undersigned, Assistant Secretary, The Ohio Casualty Insurance Company, Liberty Mutual Insurance Company, and West American Insurance Company do hereby certify that the original power of attorney of which the foregoing is a full, true and correct copy of the Power of Attorney executed by said Companies, is in full force and effect and has not been revoked.

IN TESTIMONY WHEREOF, I have hereunto set my hand and affixed the seals of said Companies this \_\_\_ day of \_\_\_\_\_, \_\_\_\_\_.



By: Renee C. Llewellyn, Assistant Secretary

Not valid for mortgage, note, loan, letter of credit, currency rate, interest rate or residual value guarantees.

To confirm the validity of this Power of Attorney call 1-610-832-8240 between 9:00 am and 4:30 pm EST on any business day.



**NOTICE TO PROCEED**

TO: \_\_\_\_\_

Date: \_\_\_\_\_

Project: VILLAGE OF VILLA PARK  
2019 SEWER REHABILITATION PROGRAM.

You are hereby notified to commence work in accordance with the Agreement dated \_\_\_\_\_, 2019, on or before \_\_\_\_\_, 2019, and you are to complete the work by \_\_\_\_\_, 20....

Village of VILLA PARK

By \_\_\_\_\_

Title: Director of Public Works

ACCEPTANCE OF NOTICE

Receipt of the Above NOTICE TO PROCEED is hereby acknowledged

by \_\_\_\_\_

this the \_\_\_\_\_ day

of \_\_\_\_\_, 20 \_\_\_\_\_

By \_\_\_\_\_

Title \_\_\_\_\_

*This page intentionally left blank.*

**OWNER COPY**

**CONTRACT**

**VILLAGE OF VILLA PARK**

CHANGE ORDER NUMBER

**PROJECT: 2018 SEWER REHABILITATION PROGRAM**

**CONTRACTOR:**

**DATE OF CONTRACT TIME START:**

**AWARDED CONTRACT AMOUNT**

**CHANGES ORDERED HEREWITH:**

ITEM NO.	PAY ITEM	UNITS	PREVIOUS QUANTITY	REVISED QUANTITY	UNIT PRICE	AMOUNT CHANGE

**TOTAL ADDITIONS**

**TOTAL DEDUCTIONS**

**TOTAL CHANGE ORDER AMOUNT**

**REASON FOR CHANGE ORDER:**

CONTRACT AMOUNT		CONTRACT TIME (CALENDAR DAYS)	
		SUBSTANTIAL COMPLETION	FINAL COMPLETION
AWARDED CONTRACT AMOUNT	_____	ORIGINAL	_____
PREVIOUS CHANGE ORDERS (+/-)	_____	PREVIOUS C.O.'S (+/-)	_____
THIS CHANGE ORDER (+/-)	_____	THIS C.O. (+/-)	_____
TOTAL CHANGE ORDERS (+/-)	_____	REVISED	_____
ADJUSTED CONTRACT AMOUNT	_____	ORIG. COMPLETION DATE	_____
		REV. COMPLETION DATE	_____

It is mutually agreed by Owner and Contractor that this change order includes any and all costs associated with or resulting from the changes ordered herein, including all impact, delays, and acceleration costs. Other than the dollar amount and time allowance listed above, there shall be no further time or dollar compensation as a result of this change order. This document shall become an amendment to the Contract and all stipulations and covenants of the Contract shall apply hereto.

\_\_\_\_\_  
 CONTRACTOR  
  
**VILLAGE OF VILLA PARK**  
 OWNER

**BY:** \_\_\_\_\_ **DATE** \_\_\_\_\_  
  
**BY:** \_\_\_\_\_ **DATE** \_\_\_\_\_

*This page intentionally left blank.*

**OWNER COPY**

**CONTRACT**

General Decision Number: IL190011 06/07/2019 IL11

Superseded General Decision Number: IL20180011

State: Illinois

Construction Types: Heavy and Highway

Counties: Boone, De Kalb, Du Page, Kane, Kendall, Lake, McHenry and Will Counties in Illinois.

HEAVY AND HIGHWAY CONSTRUCTION PROJECTS (does not include landscape projects).

Note: Under Executive Order (EO) 13658, an hourly minimum wage of \$10.60 for calendar year 2019 applies to all contracts subject to the Davis-Bacon Act for which the contract is awarded (and any solicitation was issued) on or after January 1, 2015. If this contract is covered by the EO, the contractor must pay all workers in any classification listed on this wage determination at least \$10.60 per hour (or the applicable wage rate listed on this wage determination, if it is higher) for all hours spent performing on the contract in calendar year 2019. If this contract is covered by the EO and a classification considered necessary for performance of work on the contract does not appear on this wage determination, the contractor must pay workers in that classification at least the wage rate determined through the conformance process set forth in 29 CFR 5.5(a)(1)(ii) (or the EO minimum wage rate, if it is higher than the conformed wage rate). The EO minimum wage rate will be adjusted annually. Please note that this EO applies to the above-mentioned types of contracts entered into by the federal government that are subject to the Davis-Bacon Act itself, but it does not apply to contracts subject only to the Davis-Bacon Related Acts, including those set forth at 29 CFR 5.1(a)(2)-(60). Additional information on contractor requirements and worker protections under the EO is available at [www.dol.gov/whd/govcontracts](http://www.dol.gov/whd/govcontracts).

Modification Number	Publication Date
0	01/04/2019
1	03/15/2019
2	04/19/2019
3	05/10/2019
4	06/07/2019

CARP0555-003 06/01/2018

DUPAGE ANE LAKE COUNTIES

	Rates	Fringes
CARPENTER		
Building.....	\$ 47.35	32.83
Heavy & Highway.....	\$ 47.35	32.83

-----  
CARP0555-008 06/01/2016

WILL COUNTY

Rates	Fringes
-------	---------

**OWNER COPY**

**CONTRACT**

Carpenter and Piledriver.....\$ 45.35 32.30

-----  
CARP0555-011 06/01/2018

KANE, McHENRY (North of Hwy 52), AND KENDALL COUNTIES

Rates Fringes

Carpenter and Piledriver.....\$ 47.35 32.84

-----  
CARP0790-003 05/01/2019

DE KALB COUNTY

Rates Fringes

CARPENTER.....\$ 42.70 30.38

-----  
CARP0790-004 05/01/2019

CARROLL, JO DAVIESS, LEE, OGLE (Oregon and South thereof),  
STEPHENSON, and WHITESIDE COUNTIES

Rates Fringes

CARPENTER.....\$ 42.70 30.38

-----  
CARP0792-003 05/01/2019

BOONE COUNTY

Rates Fringes

CARPENTER.....\$ 45.10 27.98

-----  
ELEC0009-002 06/03/2018

WILL COUNTY

Rates Fringes

Line Construction  
Groundman.....\$ 40.48 61.52%  
Lineman and Equipment  
Operator.....\$ 51.90 61.52%

-----  
ELEC0117-001 06/04/2018

KANE (Northern Half) and McHENRY (All) COUNTIES

Rates Fringes

ELECTRICIAN.....\$ 48.64 32.60

-----  
ELEC0150-001 07/01/2017

LAKE COUNTY

Rates Fringes

ELECTRICIAN.....\$ 40.00 38.49

-----  
ELEC0176-011 06/01/2018

	Rates	Fringes
ELECTRICIAN.....	\$ 43.50	39.26

-----  
ELEC0196-001 03/04/2019

BOONE, DEKALB, DUPAGE, KANE, KENDALL, LAKE, and MCHENRY COUNTIES

	Rates	Fringes
Line Construction		
Equipment Operator.....	\$ 43.87	32.75%+6.00+A
Groundman Truck Driver.....	\$ 35.05	32.75%+6.00+A
Groundman.....	\$ 33.85	32.75%+6.00+A
Lineman, Substation Technician, Cable Splicing Technician, Digger Operator, Crane Operator 20 tons and above, and Signal Technician.....	\$ 52.59	32.75%+6.00+A

FOOTNOTE: A. PAID HOLIDAYS: Memorial Day, Independence Day, Labor Day, and Thanksgiving Day

-----  
\* ELEC0364-003 06/01/2019

BOONE (All) & DEKALB (Remainder) COUNTIES

	Rates	Fringes
ELECTRICIAN.....	\$ 47.89	35.14

-----  
ELEC0461-006 06/04/2018

DEKALB (Sandwich TWP), KANE (Southern Half) & KENDALL (All) COUNTIES

	Rates	Fringes
ELECTRICIAN.....	\$ 47.72	32.39

-----  
ELEC0701-001 06/04/2018

DUPAGE COUNTY

	Rates	Fringes
ELECTRICIAN.....	\$ 40.50	102.09%

-----  
ENGI0150-015 06/01/2018

BOONE and DE KALB COUNTIES

	Rates	Fringes
OPERATOR: Power Equipment		
Group 1.....	\$ 46.65	37.45
Group 2.....	\$ 46.10	37.45
Group 3.....	\$ 44.80	37.45
Group 4.....	\$ 43.35	37.45
Group 5.....	\$ 41.90	37.45

## POWER EQUIPMENT OPERATOR CLASSIFICATIONS

GROUP 1: Asphalt Plant; Asphalt Heater and Planer combination; Asphalt Spreader; Asphalt Silo Tender; Autograder, GOMACO or similar; Belt Loader; Caisson Rigs; Car Dumper, Central Redi-Mix Plant; Combination Backhoe Front End Loader Machine (1 cu yd or over Backhoe bucket with attachments); Backhoe with Shear attachment; Concrete Breaker (truck mounted); Concrete Conveyor; Concrete Paver over 27E cu ft; Concrete Placer; Concrete Tube Float; Cranes, all attachments; Cranes, Hammerhead, Linden, Peco and machines of a like nature; Creter Crane; Crusher, stone; Derricks; Derrick Boats; Derricks, traveling; Dredges; Field Mechanic Welder; Formless Curb and Gutter Machine; Gradall and machines of a like nature; Grader, Elevating; Grader, Motor Grader, Motor Patrol, Auto Patrol, Form Grader, Pull Grader, Subgrader; Guard Rail Post Driver mounted; Hoists, one, two, and three Drum; Hydraulic Backhoes; Locomotive, all Mucking Machine; Pile Drivers and Skid Rig; Pre-Stress Machine; Pump Cretes Dual Ram; Rock Drill-Crawler or Skid Rig; Rock Drill truck mounted; Roto Mill Grinder, 36" and over; Roto Mill Grinder, less than 36"; Slip- Form Paver; Soil Test Drill Rig, truck mounted; Straddle Buggies; GCI Crane and similar; Hydraulic Telescoping Form (tunnel); Tie Back Machine; Tractor Drawn Belt Loader; Tractor Drawn Belt Loader with attached Pusher; Tractor with boom; Tractaire with attachment; Traffic Barrier Conveyor Machine; Raised or Blind Hoe Drill (Tunnel & Shaft); Trenching Machine; Truck Mounted Concrete Pump with boom; Truck mounted Concrete Conveyor; Underground Boring and/or Mining Machines under 5 ft; Wheel Excavator & Widener (Apsco)

GROUP 2: Batch Plant; Bituminous Mixer; Bobcats over .75 cu yd; Boiler and Throttle Valve; Bulldozer; Car Loader Trailing Conveyors; Combination Backhoe Front End Loader Machine, less than 1 cu yd Backhoe Bucket with attachments; Compressor and Throttle Valve; Compressor, common receiver (3); Concrete Breaker or Hydro Hammer; Concrete Grinding Machine; Concrete Mixer or Paver 75 series to and including 27 cu ft; Concrete Spreader; Concrete Curing Machine, Burlap Machine; Belting Machine and Sealing Machine; Conveyor Muck Cars (Haglund or similar type); Finishing Machine-Concrete; Greaser Engine; Highlift Shovels or Front End Loader; Hoist-Sewer Dragging Machine; Hydraulic Boom Trucks, all attachments; Locomotives, Dinky; Pump Cretes, Squeeze Cretes-Screw Type pumps, Gypsum Bulker and Pump; Roller Asphalt; Rotary Snow Plows; Rototiller, Seaman, etc self-Propelled; Scoops-Tractor Drawn; Self-propelled Compactor; Spreader-Chip- Stone etc; Scraper; Scraper-Prime Mover in Tandem regardless of size (add \$1.00 to to Group 2 hourly rate for each hour and for each machine attached thereto); Tank Car Heater; Tractors, Push, pulling Sheeps Foot, Disc, or Compactor, etc; Tug Boats

GROUP 3: Boilers; Brooms, all power propelled; Cement Supply Tender; Compressor, Common Receiver (2); Concrete Mixer, two bag and over; Conveyor, Portable; Farm type Tractors used for mowing, seeding, etc; Fireman on Boilers; Forklift Trucks; Grouting Machines; Hoists, Automatic; Hoists, all Elevators; Hoists, Tugger single Drum; Jeep Diggers; Pipe Jacking Machines; Post- hole Digger; Power Saw, Concrete, Power Driven; Pug Mills; Rollers, other than asphalt; Seed

## OWNER COPY

## CONTRACT

and Straw Blower; Steam Generators; Stump Machine; Winch Trucks with A-Frame; Work Boats; Tamper-Form motor driven

GROUP 4: Air compressor - Small 185 and under (1 to 5 not to exceed a total of 300 ft); Air Compressor - Large over 185; Asphalt Spreader Backend Man; Combination - Small Equipment Operator; Generators - Small 50 kw and under; Generators - Large , over 50 kw; Heaters, Mechanical; Hydraulic power unit (Pile Driving, Extracting or Drilling); Light Plants All (1 to 5); Pumps, over 3" (1 to 3, not to exceed a total of 300 ft); Pumps, Well Points; Tractaire; Welding Machines (2 through 5); Winches, 4 small electric drill winches; Bobcats up to and including .75 cu yd

GROUP 5: Oilers

PREMIUM PAY:

Long Boom :

Cranes & Derricks 90' to 150' including jib receive an extra \$.50 per hour. Cranes & Derricks over 150' including jib receive an extra \$.50 per hour plus an additional \$.10 for each additional 10' of boom or jib.

Capacity Pay: Cranes & Derricks with maximum capacity exceeding 50 ton with less than 90' of boom or jib shall be compensated \$.01 per hour for each ton of the rated capacity in excess of 50 ton.

Long Boom pay and Capacity pay cannot be combined.

Crane mounted earth auger, raised and blind hole drills, and truck mounted drill rigs receive an extra \$.50 per hour.

Creter Cranes:

When the Creter Crane is equipped with a conveyor system capable of extending 70' or more, the engineer shall receive an extra \$.50 per hour.

Truck Mounted Concrete Pumps:

When the Truck Mounted Concrete Pump is equipped with a boom, which is capable of extending 90' or more, the engineer shall receive \$.50 per hour extra.

Truck Mounted Concrete Conveyor:

Truck Mounted Concrete Conveyors equipped with conveyors that are capable of extending 90' or more, the engineer shall receive an extra \$.50 per hour.

Underground Work:

Employees working in tunnels, shafts, etc. shall be paid an additional \$.40 per hour. Employees working under air pressure 1/2 pound to 7 pounds shall receive an additional \$.50 per hour. Employees working under air pressure of 7 pounds or over shall receive \$.65 per hour more.

Mining Machines- Boring Machines:

The crew operating and maintaining the Mining Machines shall be compensated an additional \$.50 per hour.

-----  
\* ENGI0150-024 06/01/2018

DUPAGE, KANE, KENDALL, LAKE, McHENRY, and WILL COUNTIES

	Rates	Fringes
OPERATOR: Power Equipment		
GROUP 1.....	\$ 49.30	38.15
GROUP 2.....	\$ 48.75	38.15
GROUP 3.....	\$ 46.70	38.15
GROUP 4.....	\$ 45.30	38.15
GROUP 5.....	\$ 44.10	38.15

**POWER EQUIPMENT OPERATOR CLASSIFICATIONS**

GROUP 1: Asphalt Plant\*; Asphalt Heater and Planer combination; Asphalt Heater Scarfire\*, Asphalt Spreader; Autograder/ GOMACO or similar; ABG Paver\*, Backhoes with Caisson attachment\*, Ballast Regulator, Belt Loader\*; Caisson Rigs\*Car Dumper, Central Redi-Mix Plant\*, Combination Backhoe; Front End Loader Machine (1 cu yd or over Backhoe bucket or with attachments); Concrete Breaker (truck mounted); Concrete Conveyor; Concrete Paver over 27E cu ft\*; Concrete Placer\*; Concrete Tube Float; Cranes, all attachments\*; Cranes, Hammerhead, Linden, Peco and machines of a like nature\*; Creter Crane; Crusher, stone; All Derricks; Derrick Boats; Derricks, traveling\*; Dowell Machine with Air Compressor (\$1.00 above Class 1); Dredges\*; Field Mechanic Welder; Formless Curb and Gutter Machine\*; Gradall and machines of a like nature\*; Grader, Elevating; Grader, Motor Grader, Motor Patrol, Auto Patrol, Form Grader, Pull Grader, Subgrader; Guard Rail Post Driver mounted\*; Hoists, one, two, and three Drum; Hydraulic Backhoes\*; Backhoes with Shear attachments\*; Mucking Machine; Pile Drivers and Skid Rig\*; Pre-Stress Machine; Pump Cretes Dual Ram (requires frequent lubrication and water)\*; Rock Drill- Crawler or Skid Rig\*; Rock Drill truck mounted\*; Rock/ Track Tamper; Roto Mill Grinder, (36" and over)\*; Slip-Form Paver\*; Soil Test Drill Rig, truck mounted\*; Straddle Buggies; Hydraulic Telescoping Form (tunnel); Tractor Drawn Belt Loader\*; Tractor Drawn Belt Loader with attached Pusher (two engineers); Tractor with boom; Tractaire with attachment; Traffic Barrier Transfer Machine\*; Trenching Machine; Truck Mounted Concrete Pump with boom\*; Underground Boring and/or Mining Machines 5 ft in diameter and over tunnel, etc.\*; Wheel Excavator\* & Widener (Apsco); Raised or Blind Hoe Drill, Tunnel & Shaft\*

GROUP 2: Batch Plant\*; Bituminous Mixer; Boiler and Throttle Valve; Bulldozer; Car Loader Trailing Conveyors; Combination Backhoe Front End Loader Machine, (less than 1 cu yd Backhoe Bucket with attachments); Compressor and Throttle Valve; Compressor, common receiver (3); Concrete Breaker or Hydro Hammer; Concrete Grinding Machine; Concrete Mixer or Paver 75 series to and including 27 cu ft; Concrete Spreader; Concrete Curing Machine; Burlap Machine; Belting Machine and Sealing Machine; Concrete Wheel Saw; Conveyor Muck Cars (Haglund or similar type); Drills (all); Finishing Machine-Concrete; Greaser Engineer; Highlift Shovels or Front End Loader; Hoist- Sewer Dragging Machine; Hydraulic Boom Trucks, all attachments; Hydro-Blaster (requires two operators); Laser Screed\*; Locomotives, Dinky; Off-Road Hauling Units (including articulating); Pump Cretes; Squeeze Cretes-Screw Type pumps, Gypsum Bulker and Pump; Roller Asphalt; Rotary Snow Plows; Rototiller, Seaman, self-Propelled; Scoops-Tractor Drawn; Self- propelled Compactor; Spreader-Chip-Stone; Scraper; Scraper-Prime Mover in Tandem regardless of size (add \$1.00 to Group 2 hourly rate for each hour and for

**OWNER COPY**

**CONTRACT**

each machine attached thereto add \$1.00 to Group 2 hourly rate for each hour); Tank Car Heater; Tractors, Push, pulling Sheeps Foot, Disc, or Compactor, etc; Tug Boats

GROUP 3: Boilers; Brooms, all power propelled; Cement Supply Tender; Compressor, Common Receiver (2); Concrete Mixer, two bag and over; Conveyor, Portable; Farm type Tractors used for mowing, seeding, etc; Fireman on Boilers; Forklift Trucks; Grouting Machines; Hoists, Automatic; Hoists, all Elevators; Hoists, Tugger single Drum; Jeep Diggers; Low Boys; Pipe Jacking Machines; Post-hole Digger; Power Saw, Concrete, Power Driven; Pug Mills; Rollers, other than asphalt; Seed and Straw Blower; Steam Generators; Stump Machine; Winch Trucks with A-Frame; Work Boats; Tamper-Form motor driven

GROUP 4: Air compressor - Small 250 and under (1 to 5 not to exceed a total of 300 ft); Air Compressor - Large over 250; Combination - Small Equipment Operator; Directional Boring Machine; Generators - Small 50 kw and under; Generators - Large , over 50 kw; Heaters, Mechanical; Hydraulic power unit (Pile Driving, Extracting or Drilling); Light Plants (1 to 5); Pumps, over 3" (1 to 3, not to exceed a total of 300 ft); Pumps, Well Points; Tractaire; Welding Machines (2 through 5); Winches, 4 small electric drill winches;

GROUP 5: Bobcats (All); Brick Forklifts; Oilers; Directional Boring

\*Requires Oiler

-----  
IRON001-014 06/01/2018

DU PAGE (Eastern 1/4), LAKE, AND MCHENRY (Hebron, Woodstock, and East thereof) COUNTIES

	Rates	Fringes
IRONWORKER		
Sheeter.....	\$ 49.08	38.28
Structural and Reinforcing..	\$ 48.83	38.28

-----  
IRON063-003 06/01/2018

LAKE, DUPAGE (Eastern 1/4) and MCHENRY (HEBRON, WOODSTOCK & EAST THEREOF) COUNTIES

	Rates	Fringes
IRONWORKER, ORNAMENTAL.....	\$ 48.05	35.93

-----  
IRON0393-003 06/01/2018

DEKALB (SOUTHEASTERN 2/3 including Sycamore and Dekalb), DUPAGE (REMAINDER), KANE, KENDALL (NORTHERN PART), and MCHENRY (SOUTHEAST 1/4) COUNTIES

	Rates	Fringes
IRONWORKER.....	\$ 45.84	35.50

KENDALL (Southern Part) and WILL COUNTIES

	Rates	Fringes
IRONWORKER.....	\$ 43.00	38.20

IRON0498-003 06/01/2018

BOONE, DEKALB (EXCEPT Southeast), and MCHENRY (Northwest) COUNTIES

	Rates	Fringes
IRONWORKER.....	\$ 39.39	38.89

LABO0002-004 06/01/2018

DUPAGE COUNTY

	Rates	Fringes
LABORER (SEWER CONSTRUCTION)		
GROUP 1.....	\$ 42.72	28.19
GROUP 2.....	\$ 42.85	28.19
GROUP 3.....	\$ 42.95	28.19
GROUP 4.....	\$ 43.07	28.19
GROUP 5.....	\$ 42.72	28.19

LABORER CLASSIFICATIONS

GROUP 1: Signalmen Top Laborers, and all other Laborers not Mentioned.

GROUP 2: Concrete Laborers; Steel Setters.

GROUP 3: Cement Carriers; Cement Mixers; Concrete Repairmen; Mortar Men; Scaffold Men; and Second Bottom Men.

GROUP 4: Bottom Men; Bracers-Bracing; Bricklayer's Tender; Catch Basin Digger; Drainlayer; Dynamiter; Form Men; Jackhammermen; Powerpac; Pipelayers; Rodders; Welders & Burners; Well Point System Men.

GROUP 5: Asbestos Abatement Laborers, Toxic and Hazardous Waste Removal Laborers & Dosimeter use (any device) Monitoring Nuclear Exposure.

LABO0002-009 06/01/2018

DU PAGE COUNTY

	Rates	Fringes
LABORER (Compressed Air)		
0 - 15 lbs.....	\$ 43.72	28.19
16 - 20 lbs.....	\$ 44.22	28.19
21 - 26 lbs.....	\$ 44.72	28.19
27 - 33 lbs.....	\$ 45.72	28.19
34 lbs and over.....	\$ 46.72	28.19
LABORER (Tunnel and Sewer)		
GROUP 1.....	\$ 42.72	28.19

**OWNER COPY**

**CONTRACT**

GROUP 2.....	\$ 42.85	28.19
GROUP 3.....	\$ 42.95	28.19
GROUP 4.....	\$ 43.07	28.19
GROUP 5.....	\$ 42.72	28.19

LABORER CLASSIFICATIONS (TUNNEL)

GROUP 1: Cage tenders; Dumpmen; Flagmen; Signalmen; Top laborers

GROUP 2: Air hoist operator; Key board operator; concrete laborer; Grout; Lock tenders (Free Air Side); Steel setters; Tuggers; Switchmen; Car pusher

GROUP 3: Concrete repairmen; Lock tenders (pressure side); Mortar men; Muckers; Grout machine operators; Track layers

GROUP 4: Air trac drill operator; Miner; Bricklayer tenders; Concrete blower operator; Drillers; Dynamiters; Erector operator; Form men; Jackhammermen; Powerpac; Mining machine operators; Mucking machine operator; Laser beam operator; Liner plate and ring setters; Shield drivers; Power knife operator; Welder- burners; Pipe jacking machine operator; skimmers; Maintenance technician

GROUP 5: Asbestos abatement laborer; Toxic and hazardous waste removal laborer; Dosimeter (any device) monitoring nuclear exposure

LABORER CLASSIFICATIONS (SEWER)

GROUP 1: Signalmen; Top laborers and All other laborers

GROUP 2: Concrete laborers and Steel setters

GROUP 3: Cement carriers; Cement mixers; Concrete repairmen; Mortar men; Scaffold men; Second Bottom men

GROUP 4: Air trac drill operator; Bottom men; Bracers-bracing; Bricklayer tenders; Catch basin diggers; Drainlayers; dynamiters; Form men; Jackhammermen; Powerpac; Pipelayers; Rodders; Welder-burners; Well point systems men

GROUP 5: Asbestos abatement laborer, Toxic and hazardous waste removal laborer; Dosimeter (any device) monitoring nuclear exposure

-----  
LAB00032-007 05/01/2018

DE KALB COUNTY

	Rates	Fringes
LABORER		
General Laborer.....	\$ 35.40	31.73
Skilled Laborer.....	\$ 38.25	31.73

LABORER CLASSIFICATIONS

General Laborer: Carpenter Tender, Tool Cribman, Fireman or Salamander Tender, Flagman, Gravel Box Man, Bumpman & Spotter, Form Handler, Material Handler, Fencing Laborer, Cleaning Lumber, Pit Man, Material Checker, Landscaper, Unloading Explosives, Laying of Sod, Planting of Trees,

**OWNER COPY**

**CONTRACT**

Asphalt Workers With Machine & Layers, Asphalt Plant Laborer, Wrecking, Fire-proofing, Driving Stakes, Stringlines for All Machinery, Window Cleaning, Demolition Worker, Explosive Handling, Trimming & Removal of Trees, Multi-Plate Pipe, Pilot Cars for Traffic Control, Power Rigging

Skilled Laborer: Asbestos Abatement Worker; Hazardous Waste Worker Handling any Materials with any Foreign Matter Harmful to Skin or Clothing, Track Labor, Cement Handler, Chloride Handler, Unloading & Laborers with Steel Workers & Re-bars, Wet Concrete Workers, Tunnel Tenders in Free Air, Batch Dumper, Mason Tender, Kettle & Tar Man, Tank Cleaner, Plastic Installer, Scaffold Worker, Motorized Buggies or Motorized Unit Used For Wet Concrete or Handling of Building Materials, Laborers With De-Watering Systems, Sewer Workers Plus Depth, Vibrator Operator; Cement Silica, Clay, Fly Ash, Lime & Plasters Handlers (Bulk or Bag); Cofferdam Worker Plus Depth, Concrete Paving, Placing, Cutting & Tying of Reinforcing, Deck Hand, Dredge Hand and Shore Laborer, Bankman on Floating Plant, Grade Checker, Power Tools, Front End Man on Chip Spreader, Caisson Worker Plus Depth, Gunnite Nozzleman, Leadman on Sewer Work, Welder, Cutter, Burner & Torchman, Chain Saw Operator, Jackhammer & Drill Operator, Layout Man and/or Tile Layer, Steel Form Setter - Street & Highway, Air Tamping Hammerman, Signal Man On Crane, Concrete Saw Operator, Screenman on Asphalt Paver, Tending Masons with Hot Material or Where Foreign Materials are used, Mortar Mixer Operator, Multiple Concrete Duct - Leadman, Luteman, Asphalt Raker Curb Asphalt Machine Operator, Ready Mix Scaleman Permanent Portable or Temporart Plant, Laborer Handling Masterplate or Similar Materials, Laser Beam Operator, Concrete Burning Machine Operator, Coring Machine Operator, Plaster Tender, Underpinning & Shoring of Buildings, Pump Man, Manhole & Catch Basin, Dirt & Stone Tamper, Hoseman on Concrete Pump.

LAB00075-002 06/01/2017

WILL COUNTY

	Rates	Fringes
LABORER		
GROUP 1.....	\$ 41.20	27.47
GROUP 2.....	\$ 41.55	27.47
GROUP 3.....	\$ 41.20	27.47
GROUP 4.....	\$ 41.55	27.47
GROUP 5.....	\$ 41.40	27.47
GROUP 6.....	\$ 41.55	27.47
GROUP 7.....	\$ 41.40	27.47

**LABORER CLASSIFICATIONS**

GROUP 1 - Mortar mixers, handling asphalt shingles; Scaffolds; Sewer and trench work (ground level down to 8 feet); Catch basin and manhole diggers, mesh handling on road work; Cement and mineral filler handler; Concrete puddlers; Batch dumpers (cement & asphalt); Vibrator operators; Sand and stone wheelers to mixer Handlers); Concrete wheelers; Airtamping hammermen; Concrete & paving breakers; Rock drillers/Jackhammermen; Chipping hammermen 1-Bag mixer; Asphalt laborer; Chain and power saws, Pit

## OWNER COPY

## CONTRACT

men; Fencing laborers; Mason tenders (mortar and brick wheeler); Kettlemen & tarmen, tank cleaners; Scaffold and staging laborers; Pot Firemen (tarmen); Heaters tender for any purpose; Water pumps (portable water pumps shall be tended by laborers if the employer determines tending is required); Rip rap; Handling of slab steel road forms in any manner, except road form setting, setting center strips, Contraction and expansion joints (road work); Unloading and handling of lumber, brick, transite materials, cast iron water pipe, reinforced concrete rods, sewer and drain tile, railroad tiles and all other creosoted materials; paving blocks and concrete forms; Handling of insulation of any type; all work involving the unloading of materials, fixtures, or furnishing, whether crated or uncrated; all mortar and composition mixers of sewer work; track laborers; Chimney and silo laborers working at a height of 1 to 48 feet; All laborers working on swinging suspended, or any type or make of scaffolding 1 to 48 feet; All laborers working inside a sphere or any type or make of tank; Working inside a sphere or any type or make of tank from bottom to a height of 48 feet; Form strippers (any type); Mechanical or motorized buggies, for concrete or masons employers; Use of skid steer loads or any other machinery which replaces the wheelbarrow or buggy; Handling multiple concrete duct or any other type of pipe used in public utility work unless otherwise specified herein; Snapping of wall ties and removal of rods; drilling of anchor bolt holes; Concrete or asphalt clipper type saws and self-propelled saws; Shoulder and grade laborers; All hydraulic electric and air or any other type of tools; Grouting and caulking; Cleaning lumber, Nail pulling, Deck hand; Dredgehand; Shore laborer; Bankmen on Floating Plant; Tool and material checkers; Signalmen and Flagmen on all construction work; Cleaning of debris; Removal of trees; Concrete curing, temporary concrete protection regardless of manner or materials used; Laborers on Apsco; Janitorial; Wrecking and demolition laborers

GROUP 2 - Sewer and drain pipe layers and multiple concrete duct or any other type of pipe used, on public utility work (ground level to 8 feet); Pumpcrete pipe handlers

GROUP 3 - Asphalt rakers; Hod carriers; Plasterer laborers; Gunnite laborers, Slab for setters on roads, highways, streets, airport runaways, and radii (any type of form) stringline men for all aforementioned work; Wagon and tower drillers on land and floating plant used on dredging; Asphalt gunners and plug men (undercoating on road work); Mortar pump laborers; Plaster pump laborers

GROUP 4 - Tunnel miners, and all laborers inside tunnel; Air blow pipemen; Torchmen (burners); Mortaring men on sewer and drain pipe (the applying of mortar and composition mixes); All bottom men on sewer work-all sewer and drain pipelayers-multiple concrete duct or any other type of pipe used on public utility work-8 feet or more below ground level, and all other sewer and trench laborers 8 feet or more below ground level regardless of excavation area; All labor work inside cofferdam; Use of a 10 foot or more drill steel for hand held drills; Caisson laborers ground level down 15 feet; All air tools 8 feet or more below ground level; All laborers working on swinging-suspended or any type or make of scaffolds, 48 feet to 100 feet; All chimney and silo laborers working at a height of 48 to 100 feet; All tamping hammers over 150 lbs.; All laborers working

**OWNER COPY**

**CONTRACT**

inside of a sphere or any type or make of tank at a height of 48 feet to 100 feet; all hydraulic, electric and air tools or any other type 8 feet or more below ground level; Vibrators-any type-8 feet or more below ground level

GROUP 5 - Gunnite nozzle men; Caisson laborers and all tamping hammers from 150 lbs and over; from 15 feet below ground level down to 50 feet; and all laborers working inside of a sphere or any type of tank for every additional 50 feet or part thereof above 100 feet in height

GROUP 6 - All underground cavern laborers; Caisson laborers 50 feet or more below ground level; Laborers working under radio active conditions (suiting up); Blasting men (Powdermen)

GROUP 7 - Dosimeter (any device) used for monitoring nuclear exposure; Asbestos abatement worker; Toxic and hazardous waste removal laborer; and chimney and silo laborers for every additional 50 feet or any part thereof above 100 feet high

-----  
LABO0149-002 06/01/2018

BOONE, KANE, KENDALL, AND McHENRY COUNTIES

	Rates	Fringes
LABORER		
GROUP 1.....	\$ 42.72	28.19
GROUP 2.....	\$ 43.00	28.19
GROUP 3.....	\$ 43.00	28.19
GROUP 4.....	\$ 43.00	28.19
GROUP 5.....	\$ 42.95	28.19
GROUP 6.....	\$ 43.07	28.19
GROUP 7.....	\$ 43.07	28.19
GROUP 8.....	\$ 42.72	28.19
GROUP 9.....	\$ 43.72	28.19

LABORER CLASSIFICATIONS

GROUP 1: Common laborer, Asphalt laborer, Asphalt plant laborer, Striping laborer, Clipper type concrete saw, Self-propelled saws

GROUP 2: Air tampers & Vibrators

GROUP 3: Mortar & Concrete mixers

GROUP 4: Stringline & form setter; Torchman (demolition), Sheeting & Cribbing, Black top rakers & lutemen, Machine screwmen

GROUP 5: Chain saw man, Jackhammer man, Drillman, Concrete breaders & air spade,

GROUP 6: Tunnel laborers, Tile layers & bottom men

GROUP 7: Caisson diggers, Dynamiters

GROUP 8: Flagman

GROUP 9: Asbestos apatement laborers, Toxic & hazardous waste removal laborers & Dosimeter (any device) monitoring nuclear exposure

**OWNER COPY**

**CONTRACT**

LAB00152-003 06/01/2017

LAKE COUNTY

	Rates	Fringes
LABORER		
GROUP 1.....	\$ 41.20	27.47
GROUP 2.....	\$ 41.28	27.47
GROUP 3.....	\$ 41.20	27.47
GROUP 4.....	\$ 41.43	27.47
GROUP 5.....	\$ 41.40	27.47
GROUP 6.....	\$ 41.40	27.47

LABORER CLASSIFICATIONS

GROUP 1: General laborers; Asphalt

GROUP 2: Cement gun laborers

GROUP 3: Asphalt Tampers and Smoothers

GROUP 4: Rakers and Lutemen; Machine screwman; Kettleman; Mixer-men, Drum-Men; Jackhammermen (Asphalt); Mite Box Spreaders; Laborers on birch overman and similar spreader equipment; Laborers on apSCO; Laborers on Air Compressors; Paving Form Setters; Jackhammerman (Concrete); Power Drive Concrete Saws

GROUP 5: Cement Gun Nozzle (Gunite)

GROUP 6: Asbestos abatement laborers; Toxic and hazardous waste removal laborers; Dosimeter (any device monitoring nuclear exposure)

PAIN0014-003 06/01/2018

LAKE and WILL COUNTIES

	Rates	Fringes
PAINTER: Brush Only.....	\$ 46.55	27.24

PAIN0030-001 07/01/2018

DE KALB, DU PAGE, KANE, KENDALL AND MCHENRY COUNTIES

	Rates	Fringes
PAINTER		
Brush, Drywall Taper/Finisher, Sandblaster, and Spray.....	\$ 46.55	21.58

PAIN0030-004 07/01/2018

BOONE, JO DAVIESS, LEE, OGLE, STEPHENSON AND WINNEBAGO COUNTIES

	Rates	Fringes
PAINTER		
Brush, Roller, Spray,		

**OWNER COPY**

**CONTRACT**

Sandblasting, Paperhanger,  
Drywall Finishing, Taper,  
and Spray Structural Steel...\$ 39.95                      22.61

-----  
PLAS0011-002 06/01/2017

WILL COUNTY

   Rates                      Fringes  
CEMENT MASON/CONCRETE FINISHER...\$ 42.00                      34.56

-----  
PLAS0011-008 06/01/2017

DE KALB, KANE, KENDALL, AND MCHENRY COUNTIES

   Rates                      Fringes  
CEMENT MASON/CONCRETE FINISHER...\$ 44.84                      31.60

-----  
PLAS0011-013 06/01/2017

LAKE COUNTY

   Rates                      Fringes  
CEMENT MASON/CONCRETE FINISHER...\$ 44.98                      31.47

-----  
PLAS0011-015 06/01/2017

BOONE COUNTY

   Rates                      Fringes  
CEMENT MASON/CONCRETE FINISHER...\$ 36.99                      26.93  
PLASTERER.....\$ 34.78                      27.28

-----  
PLAS0803-001 08/01/2010

DUPAGE COUNTY

   Rates                      Fringes  
CEMENT MASON/CONCRETE FINISHER...\$ 38.00                      24.03

-----  
\* TEAM0179-002 06/01/2017

KENDALL and WILL COUNTIES

   Rates                      Fringes  
TRUCK DRIVER  
  2 or 3 Axle Trucks.....\$ 37.68                      0.15+a  
  4 Axle Trucks.....\$ 37.83                      0.15+a  
  5 Axle Trucks.....\$ 38.03                      0.15+a  
  6 Axle Trucks.....\$ 38.23                      0.15+a

FOOTNOTES:

- a. \$733.20 per week.
- b. Lowboy rate based on number of axles

An additional \$.20 per axle shall be paid for all vehicles with more than six (6) axles.

CLASSIFICATIONS:

Group 1 - Frame Truck when used for transportation purposes; Air Compressor and Welding Machines, including those pulled by cars, pick-up trucks and tractors; Ambulances; Articulated Dumps; Batch Gate Lockers; Batch Hopperman; Car and Truck Washers; Carry Alls; Forl Lifts and Hoisters; Helpers; Mechanics Helpers and Greasers; Oil Distributors, two-man operation; Pavement Breakers; Pole Trailer, up to 40 feet; Pothole Repair Trucks; Power Mower Tractors; Quick Change Barrier; Self-Propelled Chip Spreader; Shipping and Receiving Clerks and Checkers; Skipman; Slurry Trucks, two-man operation; Slurry Trucks, Conveyor Operated - 2 or 3 man operation; Teamsters; Unskilled Dumpmen; Warehousemen and Dockmen; Truck Drivers hauling warning lights, barricades, and portable toilets on the job site

Group 2 - Dispatcher; Dump Crets and Adgetators under 7 yards; Dumpsters, Track Trucks, Euclids, Hug Bottom Dump Turnapulls or Turnatrailers when pulling other than self-loading equipment or similar equipment under 16 cubic yards; Mixer Trucks under 7 yards; Ready-Mix Plant Hopper Operator; Winch Trucks, 2 Axles

Group 3 - Dump Crets and Adgetators, 7 yards and over; Dumpsters, Track Trucks, Euclids, Hug Bottom Dump Turnapulls or Turnatrailers when pulling other than self-loading equipment or similar equipment over 16 cubic yards; Explosives and/or Fission Material Trucks; Mixer Trucks 7 yards or over; Mobile Cranes while in transit; Oil Distributors, one-man operation; Pole Trailer, over 40 feet; Pole and Expandable Trailers hauling material over 50 feet long; Slurry Trucks, one-man operation; Winch Trucks, 3 axles or more; Mechanic - \*Truck Welder and \*Truck Painter\*These classifications shall only apply in areas where and when it has been a past area practice; Asphalt Plant Operators in areas where it has been past practice

Group 4 - Dual-purpose vehicels, such as mounted crane tucks with hoist and accessories; Foreman; Master Mechanic; Self-loading equipment like P.B. and trucks with scoops on the front

\* TEAM0301-001 06/01/2017

LAKE AND MCHENRY COUNTIES

	Rates	Fringes
TRUCK DRIVER		
2-3 AXLES.....	\$ 37.69	10.15+a
4 AXLES.....	\$ 37.84	10.15+a
5 AXLES.....	\$ 38.04	10.15+a
6 AXLES.....	\$ 38.24	10.15+a

FOOTNOTES:

- a. 325.20 per week.
- b. Lowboy rate based on number of axles

An additional \$.20 per axle shall be paid for all vehicles with more than six (6) axles.

Paid Holidays: New Year's Day, Memorial Day, Independence Day, Labor Day, Thanksgiving Day, and Christmas Day.

**OWNER COPY**

**CONTRACT**

900 straight time hours or more in 1 calendar year for the same employer shall receive 1 week paid vacation; 3 years - 2 weeks paid vacation; 10 years - 3 weeks paid vacation; 20 years - 4 weeks paid vacation.

**CLASSIFICATIONS:**

Group 1 - Frame Truck when used for transportation purposes; Air Compressor and Welding Machines, including those pulled by cars, pick-up trucks and tractors; Ambulances; Articulated Dumps; Batch Gate Lockers; Batch Hopperman; Car and Truck Washers; Carry Alls; Forl Lifts and Hoisters; Helpers; Mechanics Helpers and Greasers; Oil Distributors, two-man operation; Pavement Breakers; Pole Trailer, up to 40 feet; Pothole Repair Trucks; Power Mower Tractors; Quick Change Barrier; Self-Propelled Chip Spreader; Shipping and Receiving Clerks and Checkers; Skipman; Slurry Trucks, two-man operation; Slurry Trucks, Conveyor Operated - 2 or 3 man operation; Teamsters; Unskilled Dumpmen; Warehousemen and Dockmen; Truck Drivers hauling warning lights, barricades, and portable toilets on the job site

Group 2 - Dispatcher; Dump Crets and Adgetators under 7 yards; Dumpsters, Track Trucks, Euclids, Hug Bottom Dump Turnapulls or Turnatrailers when pulling other than self-loading equipment or similar equipment under 16 cubic yards; Mixer Trucks under 7 yards; Ready-Mix Plant Hopper Operator; Winch Trucks, 2 Axles

Group 3 - Dump Crets and Adgetators, 7 yards and over; Dumpsters, Track Trucks, Euclids, Hug Bottom Dump Turnapulls or Turnatrailers when pulling other than self-loading equipment or similar equipment over 16 cubic yards; Explosives and/or Fission Material Trucks; Mixer Trucks 7 yards or over; Mobile Cranes while in transit; Oil Distributors, one-man operation; Pole Trailer, over 40 feet; Pole and Expandable Trailers hauling material over 50 feet long; Slurry Trucks, one-man operation; Winch Trucks, 3 axles or more; Mechanic - \*Truck Welder and \*Truck Painter\*These classifications shall only apply in areas where and when it has been a past area practice; Asphalt Plant Operators in areas where it has been past practice

Group 4 - Dual-purpose vehicels, such as mounted crane tucks with hoist and accessories; Foreman; Master Mechanic; Self-loading equipment like P.B. and trucks with scoops on the front

-----  
\* TEAM0325-004 06/01/2019

**BOONE and WINNEBAGO COUNTIES**

	Rates	Fringes
TRUCK DRIVER		
2 - 3 Axles.....	\$ 37.82	22.65
4 Axles.....	\$ 37.97	22.65
5 Axles.....	\$ 38.17	22.65
6 Axles.....	\$ 38.28	22.65

FOOTNOTE: An additional \$.20 per axle shall be paid for all vehicles with more than six (6) axles.

# OWNER COPY

# CONTRACT

## CLASSIFICATIONS:

Group 1 - Frame Truck when used for transportation purposes; Air Compressor and Welding Machines, including those pulled by cars, pick-up trucks and tractors; Ambulances; Batch Gate Lockers; Batch Hopperman; Car and Truck Washers; Forl Lifts and Hoisters; Helpers; Mechanics Helpers and Greasers; Oil Distributors, two-man operation; Pavement Breakers Pole Trailer, up to 40 feet; Power Mower Tractors; Skipman; Slurry Trucks, two-man operation; Teamsters; Truck Drivers hauling warning lights, barricades, and portable toilets on the job site

Group 2 - Dump Crets and Adgetators under 7 yards; Dumpsters, Track Trucks, Euclids, Hug Bottom Dump Turnapulls or Turntrailers when pulling other than self-loading equipment or similar equipment under 16 cubic yards; Mixer Trucks under 7 yards; Ready-Mix Plant Hopper Operator; Winch Trucks, 2 Axles

Group 3 - Dump Crets and Adgetators, 7 yards and over; Dumpsters, Track Trucks, Euclids, Hug Bottom Dump Turnapulls or Turntrailers when pulling other than self-loading equipment or similar equipment over 16 cubic yards; Explosives and/or Fission Material Trucks; Mixer Trucks 7 yards or over; Mobile Cranes while in transit; Oil Distributors, one-man operation Pole Trailer, over 40 feet; Pole and Expandable Trailers hauling material over 50 feet long, additional \$0.50 per hour; Slurry Trucks, one-man operation; Winch Trucks, 3 axles or more  
 \*Mechanic\*Truck Welder and Truck Painter; \*Winter Rate: Between Dec. 15 and Feb. 28 the mechanic and welder rate shall be \$2.00 less than the scheduled scale. Truck Painter and Truck Welder classifications shall only apply in areas where and when it has been a past area practice; Dual-purpose vehicels, such as mounted crane tucks with hoist and accessories

Group 4 - Foreman; Master Mechanic; Self-loading equipment like P.B. and trucks with scoops on the front

-----  
 \* TEAM0330-002 06/01/2017

## DEKALB COUNTY

	Rates	Fringes
TRUCK DRIVER		
2-3 AXLES.....	\$ 36.64	0.15+a
4 AXLES.....	\$ 36.79	0.15+a
5 AXLES.....	\$ 36.99	0.15+a
6 AXLES.....	\$ 37.19	0.15+a

FOOTNOTE: a. \$780.90 per week

An additional \$.20 per axle shall be paid for all vehicles with more than six (6) axles.

Paid Holidays: New Year's Day, Memorial Day, Independence Day, Labor Day, Thanksgiving Day, and Christmas Day.

**OWNER COPY**

**CONTRACT**

900 straight time hours or more in 1 calendar year for the same employer shall receive 1 week paid vacation; 3 years - 2 weeks paid vacation; 10 years - 3 weeks paid vacation; 20 years - 4 weeks paid vacation.

CLASSIFICATIONS:

Group 1 - Frame Truck when used for transportation purposes; Air Compressor and Welding Machines, including those pulled by cars, pick-up trucks and tractors; Ambulances; Articulated Dumps; Batch Gate Lockers; Batch Hopperman; Car and Truck Washers; Carry Alls; Forl Lifts and Hoisters; Helpers; Mechanics Helpers and Greasers; Oil Distributors, two-man operation; Pavement Breakers; Pole Trailer, up to 40 feet; Pothole Repair Trucks; Power Mower Tractors; Quick Change Barrier; Self-Propelled Chip Spreader; Shipping and Receiving Clerks and Checkers; Skipman; Slurry Trucks, two-man operation; Slurry Trucks, Conveyor Operated - 2 or 3 man operation; Teamsters; Unskilled Dumpmen; Warehousemen and Dockmen; Truck Drivers hauling warning lights, barricades, and portable toilets on the job site

Group 2 - Dispatcher; Dump Crets and Adgetators under 7 yards; Dumpsters, Track Trucks, Euclids, Hug Bottom Dump Turnapulls or Turnatrailers when pulling other than self-loading equipment or similar equipment under 16 cubic yards; Mixer Trucks under 7 yards; Ready-Mix Plant Hopper Operator; Winch Trucks, 2 Axles

Group 3 - Dump Crets and Adgetators, 7 yards and over; Dumpsters, Track Trucks, Euclids, Hug Bottom Dump Turnapulls or Turnatrailers when pulling other than self-loading equipment or similar equipment over 16 cubic yards; Explosives and/or Fission Material Trucks; Mixer Trucks 7 yards or over; Mobile Cranes while in transit; Oil Distributors, one-man operation; Pole Trailer, over 40 feet; Pole and Expandable Trailers hauling material over 50 feet long; Slurry Trucks, one-man operation; Winch Trucks, 3 axles or more; Mechanic - \*Truck Welder and \*Truck Painter\*These classifications shall only apply in areas where and when it has been a past area practice; Asphalt Plant Operators in areas where it has been past practice

Group 4 - Dual-purpose vehicels, such as mounted crane tucks with hoist and accessories; Foreman; Master Mechanic; Self-loading equipment like P.B. and trucks with scoops on the front

-----  
\* TEAM0673-003 06/01/2017

DU PAGE and KANE COUNTIES

	Rates	Fringes
TRUCK DRIVER		
2-3 AXLES.....	\$ 36.93	0.15+a
4 AXLES.....	\$ 37.08	0.15+a
5 AXLES.....	\$ 37.28	0.15+a
6 AXLES.....	\$ 37.48	0.15+a

FOOTNOTE: a. \$767.70 per week.

An additional \$.20 per axle shall be paid for all vehicles

# OWNER COPY

# CONTRACT

with more than six (6) axles.

Paid Holidays: New Year's Day, Memorial Day, Independence Day, Labor Day, Thanksgiving Day, and Christmas Day.

900 straight time hours or more in 1 calendar year for the same employer shall receive 1 week paid vacation; 3 years - 2 weeks paid vacation; 10 years - 3 weeks paid vacation; 20 years - 4 weeks paid vacation.

## CLASSIFICATIONS:

Group 1 - Frame Truck when used for transportation purposes; Air Compressor and Welding Machines, including those pulled by cars, pick-up trucks and tractors; Ambulances; Articulated Dumps; Batch Gate Lockers; Batch Hopperman; Car and Truck Washers; Carry Alls; Forl Lifts and Hoisters; Helpers; Mechanics Helpers and Greasers; Oil Distributors, two-man operation; Pavement Breakers; Pole Trailer, up to 40 feet; Pothole Repair Trucks; Power Mower Tractors; Quick Change Barrier; Self-Propelled Chip Spreader; Shipping and Receiving Clerks and Checkers; Skipman; Slurry Trucks, two-man operation; Slurry Trucks, Conveyor Operated - 2 or 3 man operation; Teamsters; Unskilled Dumpmen; Warehousemen and Dockmen; Truck Drivers hauling warning lights, barricades, and portable toilets on the job site

Group 2 - Dispatcher; Dump Crets and Adgetators under 7 yards; Dumpsters, Track Trucks, Euclids, Hug Bottom Dump Turnapulls or Turnatrailers when pulling other than self-loading equipment or similar equipment under 16 cubic yards; Mixer Trucks under 7 yards; Ready-Mix Plant Hopper Operator; Winch Trucks, 2 Axles

Group 3 - Dump Crets and Adgetators, 7 yards and over; Dumpsters, Track Trucks, Euclids, Hug Bottom Dump Turnapulls or Turnatrailers when pulling other than self-loading equipment or similar equipment over 16 cubic yards; Explosives and/or Fission Material Trucks; Mixer Trucks 7 yards or over; Mobile Cranes while in transit; Oil Distributors, one-man operation; Pole Trailer, over 40 feet; Pole and Expandable Trailers hauling material over 50 feet long; Slurry Trucks, one-man operation; Winch Trucks, 3 axles or more; Mechanic - \*Truck Welder and \*Truck Painter\*These classifications shall only apply in areas where and when it has been a past area practice; Asphalt Plant Operators in areas where it has been past practice

Group 4 - Dual-purpose vehicels, such as mounted crane tucks with hoist and accessories; Foreman; Master Mechanic; Self-loading equipment like P.B. and trucks with scoops on the front

-----  
WELDERS - Receive rate prescribed for craft performing operation to which welding is incidental.

=====  
Note: Executive Order (EO) 13706, Establishing Paid Sick Leave for Federal Contractors applies to all contracts subject to the Davis-Bacon Act for which the contract is awarded (and any solicitation was issued) on or after January 1, 2017. If this

# OWNER COPY

# CONTRACT

contract is covered by the EO, the contractor must provide employees with 1 hour of paid sick leave for every 30 hours they work, up to 56 hours of paid sick leave each year. Employees must be permitted to use paid sick leave for their own illness, injury or other health-related needs, including preventive care; to assist a family member (or person who is like family to the employee) who is ill, injured, or has other health-related needs, including preventive care; or for reasons resulting from, or to assist a family member (or person who is like family to the employee) who is a victim of, domestic violence, sexual assault, or stalking. Additional information on contractor requirements and worker protections under the EO is available at [www.dol.gov/whd/govcontracts](http://www.dol.gov/whd/govcontracts).

Unlisted classifications needed for work not included within the scope of the classifications listed may be added after award only as provided in the labor standards contract clauses (29CFR 5.5 (a) (1) (ii)).

-----

The body of each wage determination lists the classification and wage rates that have been found to be prevailing for the cited type(s) of construction in the area covered by the wage determination. The classifications are listed in alphabetical order of "identifiers" that indicate whether the particular rate is a union rate (current union negotiated rate for local), a survey rate (weighted average rate) or a union average rate (weighted union average rate).

## Union Rate Identifiers

A four letter classification abbreviation identifier enclosed in dotted lines beginning with characters other than "SU" or "UAVG" denotes that the union classification and rate were prevailing for that classification in the survey. Example: PLUM0198-005 07/01/2014. PLUM is an abbreviation identifier of the union which prevailed in the survey for this classification, which in this example would be Plumbers. 0198 indicates the local union number or district council number where applicable, i.e., Plumbers Local 0198. The next number, 005 in the example, is an internal number used in processing the wage determination. 07/01/2014 is the effective date of the most current negotiated rate, which in this example is July 1, 2014.

Union prevailing wage rates are updated to reflect all rate changes in the collective bargaining agreement (CBA) governing this classification and rate.

## Survey Rate Identifiers

Classifications listed under the "SU" identifier indicate that no one rate prevailed for this classification in the survey and the published rate is derived by computing a weighted average rate based on all the rates reported in the survey for that classification. As this weighted average rate includes all rates reported in the survey, it may include both union and non-union rates. Example: SULA2012-007 5/13/2014. SU indicates the rates are survey rates based on a weighted average calculation of rates and are not majority rates. LA indicates the State of Louisiana. 2012 is the year of survey on which these classifications and rates are based. The next number, 007

## OWNER COPY

## CONTRACT

in the example, is an internal number used in producing the wage determination. 5/13/2014 indicates the survey completion date for the classifications and rates under that identifier.

Survey wage rates are not updated and remain in effect until a new survey is conducted.

### Union Average Rate Identifiers

Classification(s) listed under the UAVG identifier indicate that no single majority rate prevailed for those classifications; however, 100% of the data reported for the classifications was union data. EXAMPLE: UAVG-OH-0010 08/29/2014. UAVG indicates that the rate is a weighted union average rate. OH indicates the state. The next number, 0010 in the example, is an internal number used in producing the wage determination. 08/29/2014 indicates the survey completion date for the classifications and rates under that identifier.

A UAVG rate will be updated once a year, usually in January of each year, to reflect a weighted average of the current negotiated/CBA rate of the union locals from which the rate is based.

---

### WAGE DETERMINATION APPEALS PROCESS

1.) Has there been an initial decision in the matter? This can be:

- \* an existing published wage determination
- \* a survey underlying a wage determination
- \* a Wage and Hour Division letter setting forth a position on a wage determination matter
- \* a conformance (additional classification and rate) ruling

On survey related matters, initial contact, including requests for summaries of surveys, should be with the Wage and Hour Regional Office for the area in which the survey was conducted because those Regional Offices have responsibility for the Davis-Bacon survey program. If the response from this initial contact is not satisfactory, then the process described in 2.) and 3.) should be followed.

With regard to any other matter not yet ripe for the formal process described here, initial contact should be with the Branch of Construction Wage Determinations. Write to:

Branch of Construction Wage Determinations  
Wage and Hour Division  
U.S. Department of Labor  
200 Constitution Avenue, N.W.  
Washington, DC 20210

2.) If the answer to the question in 1.) is yes, then an interested party (those affected by the action) can request review and reconsideration from the Wage and Hour Administrator (See 29 CFR Part 1.8 and 29 CFR Part 7). Write to:

Wage and Hour Administrator  
U.S. Department of Labor  
200 Constitution Avenue, N.W.

The request should be accompanied by a full statement of the interested party's position and by any information (wage payment data, project description, area practice material, etc.) that the requestor considers relevant to the issue.

3.) If the decision of the Administrator is not favorable, an interested party may appeal directly to the Administrative Review Board (formerly the Wage Appeals Board). Write to:

Administrative Review Board  
U.S. Department of Labor  
200 Constitution Avenue, N.W.  
Washington, DC 20210

4.) All decisions by the Administrative Review Board are final.

=====

END OF GENERAL DECISION

This document has important legal consequences; consultation with an attorney is encouraged with respect to its use or modification. This document should be adapted to the particular circumstances of the contemplated Project and the controlling Laws and Regulations.

**STANDARD GENERAL CONDITIONS  
OF THE CONSTRUCTION CONTRACT**

Prepared by



Issued and Published Jointly by



These General Conditions have been prepared for use with the Agreement Between Owner and Contractor for Construction Contract (EJCDC® C-520, Stipulated Sum, or C-525, Cost-Plus, 2013 Editions). Their provisions are interrelated and a change in one may necessitate a change in the other.

To prepare supplementary conditions that are coordinated with the General Conditions, use EJCDC's Guide to the Preparation of Supplementary Conditions (EJCDC® C-800, 2013 Edition). The full EJCDC Construction series of documents is discussed in the Commentary on the 2013 EJCDC Construction Documents (EJCDC® C-001, 2013 Edition).

Copyright © 2013:

National Society of Professional Engineers  
1420 King Street, Alexandria, VA 22314-2794  
(703) 684-2882  
[www.nspe.org](http://www.nspe.org)

American Council of Engineering Companies  
1015 15th Street N.W., Washington, DC 20005  
(202) 347-7474  
[www.acec.org](http://www.acec.org)

American Society of Civil Engineers  
1801 Alexander Bell Drive, Reston, VA 20191-4400  
(800) 548-2723  
[www.asce.org](http://www.asce.org)

The copyright for this document is owned jointly by the three sponsoring organizations listed above. The National Society of Professional Engineers is the Copyright Administrator for the EJCDC documents; please direct all inquiries regarding EJCDC copyrights to NSPE.

NOTE: EJCDC publications may be purchased at [www.ejcdc.org](http://www.ejcdc.org), or from any of the sponsoring organizations above.

**STANDARD GENERAL CONDITIONS OF THE  
CONSTRUCTION CONTRACT**

**TABLE OF CONTENTS**

	<b>Page</b>
Article 1 – Definitions and Terminology .....	1
1.01 Defined Terms .....	1
1.02 Terminology .....	5
Article 2 – Preliminary Matters .....	6
2.01 Delivery of Bonds and Evidence of Insurance .....	6
2.02 Copies of Documents .....	6
2.03 Before Starting Construction .....	6
2.04 Preconstruction Conference; Designation of Authorized Representatives .....	7
2.05 Initial Acceptance of Schedules .....	7
2.06 Electronic Transmittals.....	7
Article 3 – Documents: Intent, Requirements, Reuse .....	8
3.01 Intent.....	8
3.02 Reference Standards.....	8
3.03 Reporting and Resolving Discrepancies .....	8
3.04 Requirements of the Contract Documents .....	9
3.05 Reuse of Documents .....	10
Article 4 – Commencement and Progress of the Work .....	10
4.01 Commencement of Contract Times; Notice to Proceed .....	10
4.02 Starting the Work .....	10
4.03 Reference Points .....	10
4.04 Progress Schedule .....	10
4.05 Delays in Contractor’s Progress .....	11
Article 5 – Availability of Lands; Subsurface and Physical Conditions; Hazardous Environmental Conditions .....	12
5.01 Availability of Lands .....	12
5.02 Use of Site and Other Areas .....	12
5.03 Subsurface and Physical Conditions.....	13
5.04 Differing Subsurface or Physical Conditions .....	14
5.05 Underground Facilities .....	15

5.06 Hazardous Environmental Conditions at Site ..... 17

Article 6 – Bonds and Insurance ..... 19

6.01 Performance, Payment, and Other Bonds ..... 19

6.02 Insurance—General Provisions ..... 19

6.03 Contractor’s Insurance ..... 20

6.04 Owner’s Liability Insurance ..... 23

6.05 Property Insurance ..... 23

6.06 Waiver of Rights ..... 25

6.07 Receipt and Application of Property Insurance Proceeds ..... 25

Article 7 – Contractor’s Responsibilities ..... 26

7.01 Supervision and Superintendence ..... 26

7.02 Labor; Working Hours ..... 26

7.03 Services, Materials, and Equipment ..... 26

7.04 “Or Equals” ..... 27

7.05 Substitutes ..... 28

7.06 Concerning Subcontractors, Suppliers, and Others ..... 29

7.07 Patent Fees and Royalties ..... 31

7.08 Permits ..... 31

7.09 Taxes ..... 32

7.10 Laws and Regulations ..... 32

7.11 Record Documents ..... 32

7.12 Safety and Protection ..... 32

7.13 Safety Representative ..... 33

7.14 Hazard Communication Programs ..... 33

7.15 Emergencies ..... 34

7.16 Shop Drawings, Samples, and Other Submittals ..... 34

7.17 Contractor’s General Warranty and Guarantee ..... 36

7.18 Indemnification ..... 37

7.19 Delegation of Professional Design Services ..... 37

Article 8 – Other Work at the Site ..... 38

8.01 Other Work ..... 38

8.02 Coordination ..... 39

8.03 Legal Relationships ..... 39

Article 9 – Owner’s Responsibilities..... 40

- 9.01 Communications to Contractor..... 40
- 9.02 Replacement of Engineer ..... 40
- 9.03 Furnish Data ..... 40
- 9.04 Pay When Due..... 40
- 9.05 Lands and Easements; Reports, Tests, and Drawings ..... 40
- 9.06 Insurance ..... 40
- 9.07 Change Orders..... 40
- 9.08 Inspections, Tests, and Approvals..... 41
- 9.09 Limitations on Owner’s Responsibilities ..... 41
- 9.10 Undisclosed Hazardous Environmental Condition..... 41
- 9.11 Evidence of Financial Arrangements..... 41
- 9.12 Safety Programs ..... 41

Article 10 – Engineer’s Status During Construction ..... 41

- 10.01 Owner’s Representative..... 41
- 10.02 Visits to Site..... 41
- 10.03 Project Representative..... 42
- 10.04 Rejecting Defective Work..... 42
- 10.05 Shop Drawings, Change Orders and Payments..... 42
- 10.06 Determinations for Unit Price Work ..... 42
- 10.07 Decisions on Requirements of Contract Documents and Acceptability of Work ..... 42
- 10.08 Limitations on Engineer’s Authority and Responsibilities..... 42
- 10.09 Compliance with Safety Program..... 43

Article 11 – Amending the Contract Documents; Changes in the Work ..... 43

- 11.01 Amending and Supplementing Contract Documents ..... 43
- 11.02 Owner-Authorized Changes in the Work ..... 44
- 11.03 Unauthorized Changes in the Work ..... 44
- 11.04 Change of Contract Price ..... 44
- 11.05 Change of Contract Times ..... 45
- 11.06 Change Proposals ..... 45
- 11.07 Execution of Change Orders..... 46
- 11.08 Notification to Surety..... 47

Article 12 – Claims..... 47

12.01 Claims ..... 47

Article 13 – Cost of the Work; Allowances; Unit Price Work..... 48

13.01 Cost of the Work ..... 48

13.02 Allowances ..... 50

13.03 Unit Price Work ..... 51

Article 14 – Tests and Inspections; Correction, Removal or Acceptance of Defective Work..... 52

14.01 Access to Work..... 52

14.02 Tests, Inspections, and Approvals ..... 52

14.03 Defective Work..... 53

14.04 Acceptance of Defective Work..... 53

14.05 Uncovering Work ..... 53

14.06 Owner May Stop the Work ..... 54

14.07 Owner May Correct Defective Work..... 54

Article 15 – Payments to Contractor; Set-Offs; Completion; Correction Period ..... 55

15.01 Progress Payments ..... 55

15.02 Contractor’s Warranty of Title ..... 58

15.03 Substantial Completion ..... 58

15.04 Partial Use or Occupancy ..... 59

15.05 Final Inspection ..... 59

15.06 Final Payment..... 59

15.07 Waiver of Claims ..... 61

15.08 Correction Period ..... 61

Article 16 – Suspension of Work and Termination ..... 62

16.01 Owner May Suspend Work ..... 62

16.02 Owner May Terminate for Cause ..... 62

16.03 Owner May Terminate For Convenience ..... 63

16.04 Contractor May Stop Work or Terminate ..... 63

Article 17 – Final Resolution of Disputes ..... 64

17.01 Methods and Procedures ..... 64

Article 18 – Miscellaneous ..... 64

18.01 Giving Notice ..... 64

18.02 Computation of Times..... 64

18.03 Cumulative Remedies ..... 64

18.04 Limitation of Damages ..... 65  
18.05 No Waiver ..... 65  
18.06 Survival of Obligations ..... 65  
18.07 Controlling Law ..... 65  
18.08 Headings..... 65

**ARTICLE 1 – DEFINITIONS AND TERMINOLOGY****1.01 Defined Terms**

- A. Wherever used in the Bidding Requirements or Contract Documents, a term printed with initial capital letters, including the term's singular and plural forms, will have the meaning indicated in the definitions below. In addition to terms specifically defined, terms with initial capital letters in the Contract Documents include references to identified articles and paragraphs, and the titles of other documents or forms.
1. *Addenda*—Written or graphic instruments issued prior to the opening of Bids which clarify, correct, or change the Bidding Requirements or the proposed Contract Documents.
  2. *Agreement*—The written instrument, executed by Owner and Contractor, that sets forth the Contract Price and Contract Times, identifies the parties and the Engineer, and designates the specific items that are Contract Documents.
  3. *Application for Payment*—The form acceptable to Engineer which is to be used by Contractor during the course of the Work in requesting progress or final payments and which is to be accompanied by such supporting documentation as is required by the Contract Documents.
  4. *Bid*—The offer of a Bidder submitted on the prescribed form setting forth the prices for the Work to be performed.
  5. *Bidder*—An individual or entity that submits a Bid to Owner.
  6. *Bidding Documents*—The Bidding Requirements, the proposed Contract Documents, and all Addenda.
  7. *Bidding Requirements*—The advertisement or invitation to bid, Instructions to Bidders, Bid Bond or other Bid security, if any, the Bid Form, and the Bid with any attachments.
  8. *Change Order*—A document which is signed by Contractor and Owner and authorizes an addition, deletion, or revision in the Work or an adjustment in the Contract Price or the Contract Times, or other revision to the Contract, issued on or after the Effective Date of the Contract.
  9. *Change Proposal*—A written request by Contractor, duly submitted in compliance with the procedural requirements set forth herein, seeking an adjustment in Contract Price or Contract Times, or both; contesting an initial decision by Engineer concerning the requirements of the Contract Documents or the acceptability of Work under the Contract Documents; challenging a set-off against payments due; or seeking other relief with respect to the terms of the Contract.
  10. *Claim*—(a) A demand or assertion by Owner directly to Contractor, duly submitted in compliance with the procedural requirements set forth herein: seeking an adjustment of Contract Price or Contract Times, or both; contesting an initial decision by Engineer concerning the requirements of the Contract Documents or the acceptability of Work under the Contract Documents; contesting Engineer's decision regarding a Change Proposal; seeking resolution of a contractual issue that Engineer has declined to address; or seeking other relief with respect to the terms of the Contract; or (b) a demand or assertion by Contractor directly to Owner, duly submitted in compliance with the procedural requirements set forth herein, contesting Engineer's decision regarding a Change Proposal; or seeking resolution of a contractual issue that Engineer

- has declined to address. A demand for money or services by a third party is not a Claim.
11. *Constituent of Concern*—Asbestos, petroleum, radioactive materials, polychlorinated biphenyls (PCBs), hazardous waste, and any substance, product, waste, or other material of any nature whatsoever that is or becomes listed, regulated, or addressed pursuant to (a) the Comprehensive Environmental Response, Compensation and Liability Act, 42 U.S.C. §§9601 et seq. (“CERCLA”); (b) the Hazardous Materials Transportation Act, 49 U.S.C. §§5501 et seq.; (c) the Resource Conservation and Recovery Act, 42 U.S.C. §§6901 et seq. (“RCRA”); (d) the Toxic Substances Control Act, 15 U.S.C. §§2601 et seq.; (e) the Clean Water Act, 33 U.S.C. §§1251 et seq.; (f) the Clean Air Act, 42 U.S.C. §§7401 et seq.; or (g) any other federal, state, or local statute, law, rule, regulation, ordinance, resolution, code, order, or decree regulating, relating to, or imposing liability or standards of conduct concerning, any hazardous, toxic, or dangerous waste, substance, or material.
  12. *Contract*—The entire and integrated written contract between the Owner and Contractor concerning the Work.
  13. *Contract Documents*—Those items so designated in the Agreement, and which together comprise the Contract.
  14. *Contract Price*—The money that Owner has agreed to pay Contractor for completion of the Work in accordance with the Contract Documents. .
  15. *Contract Times*—The number of days or the dates by which Contractor shall: (a) achieve Milestones, if any; (b) achieve Substantial Completion; and (c) complete the Work.
  16. *Contractor*—The individual or entity with which Owner has contracted for performance of the Work.
  17. *Cost of the Work*—See Paragraph 13.01 for definition.
  18. *Drawings*—The part of the Contract that graphically shows the scope, extent, and character of the Work to be performed by Contractor.
  19. *Effective Date of the Contract*—The date, indicated in the Agreement, on which the Contract becomes effective.
  20. *Engineer*—The individual or entity named as such in the Agreement.
  21. *Field Order*—A written order issued by Engineer which requires minor changes in the Work but does not change the Contract Price or the Contract Times.
  22. *Hazardous Environmental Condition*—The presence at the Site of Constituents of Concern in such quantities or circumstances that may present a danger to persons or property exposed thereto. The presence at the Site of materials that are necessary for the execution of the Work, or that are to be incorporated in the Work, and that are controlled and contained pursuant to industry practices, Laws and Regulations, and the requirements of the Contract, does not establish a Hazardous Environmental Condition.
  23. *Laws and Regulations; Laws or Regulations*—Any and all applicable laws, statutes, rules, regulations, ordinances, codes, and orders of any and all governmental bodies, agencies, authorities, and courts having jurisdiction.

24. *Liens*—Charges, security interests, or encumbrances upon Contract-related funds, real property, or personal property.
25. *Milestone*—A principal event in the performance of the Work that the Contract requires Contractor to achieve by an intermediate completion date or by a time prior to Substantial Completion of all the Work.
26. *Notice of Award*—The written notice by Owner to a Bidder of Owner’s acceptance of the Bid.
27. *Notice to Proceed*—A written notice by Owner to Contractor fixing the date on which the Contract Times will commence to run and on which Contractor shall start to perform the Work.
28. *Owner*—The individual or entity with which Contractor has contracted regarding the Work, and which has agreed to pay Contractor for the performance of the Work, pursuant to the terms of the Contract.
29. *Progress Schedule*—A schedule, prepared and maintained by Contractor, describing the sequence and duration of the activities comprising the Contractor’s plan to accomplish the Work within the Contract Times.
30. *Project*—The total undertaking to be accomplished for Owner by engineers, contractors, and others, including planning, study, design, construction, testing, commissioning, and start-up, and of which the Work to be performed under the Contract Documents is a part.
31. *Project Manual*—The written documents prepared for, or made available for, procuring and constructing the Work, including but not limited to the Bidding Documents or other construction procurement documents, geotechnical and existing conditions information, the Agreement, bond forms, General Conditions, Supplementary Conditions, and Specifications. The contents of the Project Manual may be bound in one or more volumes.
32. *Resident Project Representative*—The authorized representative of Engineer assigned to assist Engineer at the Site. As used herein, the term Resident Project Representative or “RPR” includes any assistants or field staff of Resident Project Representative.
33. *Samples*—Physical examples of materials, equipment, or workmanship that are representative of some portion of the Work and that establish the standards by which such portion of the Work will be judged.
34. *Schedule of Submittals*—A schedule, prepared and maintained by Contractor, of required submittals and the time requirements for Engineer’s review of the submittals and the performance of related construction activities.
35. *Schedule of Values*—A schedule, prepared and maintained by Contractor, allocating portions of the Contract Price to various portions of the Work and used as the basis for reviewing Contractor’s Applications for Payment.
36. *Shop Drawings*—All drawings, diagrams, illustrations, schedules, and other data or information that are specifically prepared or assembled by or for Contractor and submitted by Contractor to illustrate some portion of the Work. Shop Drawings, whether approved or not, are not Drawings and are not Contract Documents.

37. *Site*—Lands or areas indicated in the Contract Documents as being furnished by Owner upon which the Work is to be performed, including rights-of-way and easements, and such other lands furnished by Owner which are designated for the use of Contractor.
38. *Specifications*—The part of the Contract that consists of written requirements for materials, equipment, systems, standards, and workmanship as applied to the Work, and certain administrative requirements and procedural matters applicable to the Work.
39. *Subcontractor*—An individual or entity having a direct contract with Contractor or with any other Subcontractor for the performance of a part of the Work.
40. *Substantial Completion*—The time at which the Work (or a specified part thereof) has progressed to the point where, in the opinion of Engineer, the Work (or a specified part thereof) is sufficiently complete, in accordance with the Contract Documents, so that the Work (or a specified part thereof) can be utilized for the purposes for which it is intended. The terms “substantially complete” and “substantially completed” as applied to all or part of the Work refer to Substantial Completion thereof.
41. *Successful Bidder*—The Bidder whose Bid the Owner accepts, and to which the Owner makes an award of contract, subject to stated conditions.
42. *Supplementary Conditions*—The part of the Contract that amends or supplements these General Conditions.
43. *Supplier*—A manufacturer, fabricator, supplier, distributor, materialman, or vendor having a direct contract with Contractor or with any Subcontractor to furnish materials or equipment to be incorporated in the Work by Contractor or a Subcontractor.
44. *Technical Data*—Those items expressly identified as Technical Data in the Supplementary Conditions, with respect to either (a) subsurface conditions at the Site, or physical conditions relating to existing surface or subsurface structures at the Site (except Underground Facilities) or (b) Hazardous Environmental Conditions at the Site. If no such express identifications of Technical Data have been made with respect to conditions at the Site, then the data contained in boring logs, recorded measurements of subsurface water levels, laboratory test results, and other factual, objective information regarding conditions at the Site that are set forth in any geotechnical or environmental report prepared for the Project and made available to Contractor are hereby defined as Technical Data with respect to conditions at the Site under Paragraphs 5.03, 5.04, and 5.06.
45. *Underground Facilities*—All underground pipelines, conduits, ducts, cables, wires, manholes, vaults, tanks, tunnels, or other such facilities or attachments, and any encasements containing such facilities, including but not limited to those that convey electricity, gases, steam, liquid petroleum products, telephone or other communications, fiber optic transmissions, cable television, water, wastewater, storm water, other liquids or chemicals, or traffic or other control systems.
46. *Unit Price Work*—Work to be paid for on the basis of unit prices.
47. *Work*—The entire construction or the various separately identifiable parts thereof required to be provided under the Contract Documents. Work includes and is the result of performing or providing all labor, services, and documentation necessary to produce such construction; furnishing, installing, and incorporating all materials and equipment into such construction; and may include related services such as testing, start-up, and commissioning, all as required by the Contract Documents.

48. *Work Change Directive*—A written directive to Contractor issued on or after the Effective Date of the Contract, signed by Owner and recommended by Engineer, ordering an addition, deletion, or revision in the Work.

1.02 *Terminology*

- A. The words and terms discussed in the following paragraphs are not defined but, when used in the Bidding Requirements or Contract Documents, have the indicated meaning.
- B. *Intent of Certain Terms or Adjectives:*
1. The Contract Documents include the terms “as allowed,” “as approved,” “as ordered,” “as directed” or terms of like effect or import to authorize an exercise of professional judgment by Engineer. In addition, the adjectives “reasonable,” “suitable,” “acceptable,” “proper,” “satisfactory,” or adjectives of like effect or import are used to describe an action or determination of Engineer as to the Work. It is intended that such exercise of professional judgment, action, or determination will be solely to evaluate, in general, the Work for compliance with the information in the Contract Documents and with the design concept of the Project as a functioning whole as shown or indicated in the Contract Documents (unless there is a specific statement indicating otherwise). The use of any such term or adjective is not intended to and shall not be effective to assign to Engineer any duty or authority to supervise or direct the performance of the Work, or any duty or authority to undertake responsibility contrary to the provisions of Article 10 or any other provision of the Contract Documents.
- C. *Day:*
1. The word “day” means a calendar day of 24 hours measured from midnight to the next midnight.
- D. *Defective:*
1. The word “defective,” when modifying the word “Work,” refers to Work that is unsatisfactory, faulty, or deficient in that it:
    - a. does not conform to the Contract Documents; or
    - b. does not meet the requirements of any applicable inspection, reference standard, test, or approval referred to in the Contract Documents; or
    - c. has been damaged prior to Engineer’s recommendation of final payment (unless responsibility for the protection thereof has been assumed by Owner at Substantial Completion in accordance with Paragraph 15.03 or 15.04).
- E. *Furnish, Install, Perform, Provide:*
1. The word “furnish,” when used in connection with services, materials, or equipment, shall mean to supply and deliver said services, materials, or equipment to the Site (or some other specified location) ready for use or installation and in usable or operable condition.
  2. The word “install,” when used in connection with services, materials, or equipment, shall mean to put into use or place in final position said services, materials, or equipment complete and ready for intended use.

3. The words “perform” or “provide,” when used in connection with services, materials, or equipment, shall mean to furnish and install said services, materials, or equipment complete and ready for intended use.
  4. If the Contract Documents establish an obligation of Contractor with respect to specific services, materials, or equipment, but do not expressly use any of the four words “furnish,” “install,” “perform,” or “provide,” then Contractor shall furnish and install said services, materials, or equipment complete and ready for intended use.
- F. Unless stated otherwise in the Contract Documents, words or phrases that have a well-known technical or construction industry or trade meaning are used in the Contract Documents in accordance with such recognized meaning.

## ARTICLE 2 – PRELIMINARY MATTERS

### 2.01 *Delivery of Bonds and Evidence of Insurance*

- A. *Bonds*: When Contractor delivers the executed counterparts of the Agreement to Owner, Contractor shall also deliver to Owner such bonds as Contractor may be required to furnish.
- B. *Evidence of Contractor’s Insurance*: When Contractor delivers the executed counterparts of the Agreement to Owner, Contractor shall also deliver to Owner, with copies to each named insured and additional insured (as identified in the Supplementary Conditions or elsewhere in the Contract), the certificates and other evidence of insurance required to be provided by Contractor in accordance with Article 6.
- C. *Evidence of Owner’s Insurance*: After receipt of the executed counterparts of the Agreement and all required bonds and insurance documentation, Owner shall promptly deliver to Contractor, with copies to each named insured and additional insured (as identified in the Supplementary Conditions or otherwise), the certificates and other evidence of insurance required to be provided by Owner under Article 6.

### 2.02 *Copies of Documents*

- A. Owner shall furnish to Contractor four printed copies of the Contract (including one fully executed counterpart of the Agreement), and one copy in electronic portable document format (PDF). Additional printed copies will be furnished upon request at the cost of reproduction.
- B. Owner shall maintain and safeguard at least one original printed record version of the Contract, including Drawings and Specifications signed and sealed by Engineer and other design professionals. Owner shall make such original printed record version of the Contract available to Contractor for review. Owner may delegate the responsibilities under this provision to Engineer.

### 2.03 *Before Starting Construction*

- A. *Preliminary Schedules*: Within 10 days after the Effective Date of the Contract (or as otherwise specifically required by the Contract Documents), Contractor shall submit to Engineer for timely review:
  1. a preliminary Progress Schedule indicating the times (numbers of days or dates) for starting and completing the various stages of the Work, including any Milestones specified in the Contract;
  2. a preliminary Schedule of Submittals; and

3. a preliminary Schedule of Values for all of the Work which includes quantities and prices of items which when added together equal the Contract Price and subdivides the Work into component parts in sufficient detail to serve as the basis for progress payments during performance of the Work. Such prices will include an appropriate amount of overhead and profit applicable to each item of Work.

2.04 *Preconstruction Conference; Designation of Authorized Representatives*

- A. Before any Work at the Site is started, a conference attended by Owner, Contractor, Engineer, and others as appropriate will be held to establish a working understanding among the parties as to the Work and to discuss the schedules referred to in Paragraph 2.03.A, procedures for handling Shop Drawings, Samples, and other submittals, processing Applications for Payment, electronic or digital transmittals, and maintaining required records.
- B. At this conference Owner and Contractor each shall designate, in writing, a specific individual to act as its authorized representative with respect to the services and responsibilities under the Contract. Such individuals shall have the authority to transmit and receive information, render decisions relative to the Contract, and otherwise act on behalf of each respective party.

2.05 *Initial Acceptance of Schedules*

- A. At least 10 days before submission of the first Application for Payment a conference, attended by Contractor, Engineer, and others as appropriate, will be held to review for acceptability to Engineer as provided below the schedules submitted in accordance with Paragraph 2.03.A. Contractor shall have an additional 10 days to make corrections and adjustments and to complete and resubmit the schedules. No progress payment shall be made to Contractor until acceptable schedules are submitted to Engineer.
  1. The Progress Schedule will be acceptable to Engineer if it provides an orderly progression of the Work to completion within the Contract Times. Such acceptance will not impose on Engineer responsibility for the Progress Schedule, for sequencing, scheduling, or progress of the Work, nor interfere with or relieve Contractor from Contractor's full responsibility therefor.
  2. Contractor's Schedule of Submittals will be acceptable to Engineer if it provides a workable arrangement for reviewing and processing the required submittals.
  3. Contractor's Schedule of Values will be acceptable to Engineer as to form and substance if it provides a reasonable allocation of the Contract Price to the component parts of the Work.

2.06 *Electronic Transmittals*

- A. Except as otherwise stated elsewhere in the Contract, the Owner, Engineer, and Contractor may transmit, and shall accept, Project-related correspondence, text, data, documents, drawings, information, and graphics, including but not limited to Shop Drawings and other submittals, in electronic media or digital format, either directly, or through access to a secure Project website.
- B. If the Contract does not establish protocols for electronic or digital transmittals, then Owner, Engineer, and Contractor shall jointly develop such protocols.
- C. When transmitting items in electronic media or digital format, the transmitting party makes no representations as to long term compatibility, usability, or readability of the items resulting from the recipient's use of software application packages, operating systems, or

computer hardware differing from those used in the drafting or transmittal of the items, or from those established in applicable transmittal protocols.

### ARTICLE 3 – DOCUMENTS: INTENT, REQUIREMENTS, REUSE

#### 3.01 *Intent*

- A. The Contract Documents are complementary; what is required by one is as binding as if required by all.
- B. It is the intent of the Contract Documents to describe a functionally complete project (or part thereof) to be constructed in accordance with the Contract Documents.
- C. Unless otherwise stated in the Contract Documents, if there is a discrepancy between the electronic or digital versions of the Contract Documents (including any printed copies derived from such electronic or digital versions) and the printed record version, the printed record version shall govern.
- D. The Contract supersedes prior negotiations, representations, and agreements, whether written or oral.
- E. Engineer will issue clarifications and interpretations of the Contract Documents as provided herein.

#### 3.02 *Reference Standards*

- A. Standards Specifications, Codes, Laws and Regulations
  1. Reference in the Contract Documents to standard specifications, manuals, reference standards, or codes of any technical society, organization, or association, or to Laws or Regulations, whether such reference be specific or by implication, shall mean the standard specification, manual, reference standard, code, or Laws or Regulations in effect at the time of opening of Bids (or on the Effective Date of the Contract if there were no Bids), except as may be otherwise specifically stated in the Contract Documents.
  2. No provision of any such standard specification, manual, reference standard, or code, or any instruction of a Supplier, shall be effective to change the duties or responsibilities of Owner, Contractor, or Engineer, or any of their subcontractors, consultants, agents, or employees, from those set forth in the part of the Contract Documents prepared by or for Engineer. No such provision or instruction shall be effective to assign to Owner, Engineer, or any of their officers, directors, members, partners, employees, agents, consultants, or subcontractors, any duty or authority to supervise or direct the performance of the Work or any duty or authority to undertake responsibility inconsistent with the provisions of the part of the Contract Documents prepared by or for Engineer.

#### 3.03 *Reporting and Resolving Discrepancies*

- A. *Reporting Discrepancies:*
  1. *Contractor's Verification of Figures and Field Measurements:* Before undertaking each part of the Work, Contractor shall carefully study the Contract Documents, and check and verify pertinent figures and dimensions therein, particularly with respect to applicable field measurements. Contractor shall promptly report in writing to Engineer any conflict, error, ambiguity, or discrepancy that Contractor discovers, or has actual knowledge of, and shall not proceed with any Work affected thereby until the conflict,

error, ambiguity, or discrepancy is resolved, by a clarification or interpretation by Engineer, or by an amendment or supplement to the Contract Documents issued pursuant to Paragraph 11.01.

2. *Contractor's Review of Contract Documents:* If, before or during the performance of the Work, Contractor discovers any conflict, error, ambiguity, or discrepancy within the Contract Documents, or between the Contract Documents and (a) any applicable Law or Regulation, (b) actual field conditions, (c) any standard specification, manual, reference standard, or code, or (d) any instruction of any Supplier, then Contractor shall promptly report it to Engineer in writing. Contractor shall not proceed with the Work affected thereby (except in an emergency as required by Paragraph 7.15) until the conflict, error, ambiguity, or discrepancy is resolved, by a clarification or interpretation by Engineer, or by an amendment or supplement to the Contract Documents issued pursuant to Paragraph 11.01.
3. Contractor shall not be liable to Owner or Engineer for failure to report any conflict, error, ambiguity, or discrepancy in the Contract Documents unless Contractor had actual knowledge thereof.

**B. Resolving Discrepancies:**

1. Except as may be otherwise specifically stated in the Contract Documents, the provisions of the part of the Contract Documents prepared by or for Engineer shall take precedence in resolving any conflict, error, ambiguity, or discrepancy between such provisions of the Contract Documents and:
  - a. the provisions of any standard specification, manual, reference standard, or code, or the instruction of any Supplier (whether or not specifically incorporated by reference as a Contract Document); or
  - b. the provisions of any Laws or Regulations applicable to the performance of the Work (unless such an interpretation of the provisions of the Contract Documents would result in violation of such Law or Regulation).

**3.04 Requirements of the Contract Documents**

- A. During the performance of the Work and until final payment, Contractor and Owner shall submit to the Engineer all matters in question concerning the requirements of the Contract Documents (sometimes referred to as requests for information or interpretation—RFIs), or relating to the acceptability of the Work under the Contract Documents, as soon as possible after such matters arise. Engineer will be the initial interpreter of the requirements of the Contract Documents, and judge of the acceptability of the Work thereunder.
- B. Engineer will, with reasonable promptness, render a written clarification, interpretation, or decision on the issue submitted, or initiate an amendment or supplement to the Contract Documents. Engineer's written clarification, interpretation, or decision will be final and binding on Contractor, unless it appeals by submitting a Change Proposal, and on Owner, unless it appeals by filing a Claim.
- C. If a submitted matter in question concerns terms and conditions of the Contract Documents that do not involve (1) the performance or acceptability of the Work under the Contract Documents, (2) the design (as set forth in the Drawings, Specifications, or otherwise), or (3) other engineering or technical matters, then Engineer will promptly give written notice to Owner and Contractor that Engineer is unable to provide a decision or interpretation. If Owner and Contractor are unable to agree on resolution of such a matter in question, either party may pursue resolution as provided in Article 12.

### 3.05 *Reuse of Documents*

- A. Contractor and its Subcontractors and Suppliers shall not:
  - 1. have or acquire any title to or ownership rights in any of the Drawings, Specifications, or other documents (or copies of any thereof) prepared by or bearing the seal of Engineer or its consultants, including electronic media editions, or reuse any such Drawings, Specifications, other documents, or copies thereof on extensions of the Project or any other project without written consent of Owner and Engineer and specific written verification or adaptation by Engineer; or
  - 2. have or acquire any title or ownership rights in any other Contract Documents, reuse any such Contract Documents for any purpose without Owner's express written consent, or violate any copyrights pertaining to such Contract Documents.
- B. The prohibitions of this Paragraph 3.05 will survive final payment, or termination of the Contract. Nothing herein shall preclude Contractor from retaining copies of the Contract Documents for record purposes.

## ARTICLE 4 – COMMENCEMENT AND PROGRESS OF THE WORK

### 4.01 *Commencement of Contract Times; Notice to Proceed*

- A. The Contract Times will commence to run on the thirtieth day after the Effective Date of the Contract or, if a Notice to Proceed is given, on the day indicated in the Notice to Proceed. A Notice to Proceed may be given at any time within 30 days after the Effective Date of the Contract. In no event will the Contract Times commence to run later than the sixtieth day after the day of Bid opening or the thirtieth day after the Effective Date of the Contract, whichever date is earlier.

### 4.02 *Starting the Work*

- A. Contractor shall start to perform the Work on the date when the Contract Times commence to run. No Work shall be done at the Site prior to such date.

### 4.03 *Reference Points*

- A. Owner shall provide engineering surveys to establish reference points for construction which in Engineer's judgment are necessary to enable Contractor to proceed with the Work. Contractor shall be responsible for laying out the Work, shall protect and preserve the established reference points and property monuments, and shall make no changes or relocations without the prior written approval of Owner. Contractor shall report to Engineer whenever any reference point or property monument is lost or destroyed or requires relocation because of necessary changes in grades or locations, and shall be responsible for the accurate replacement or relocation of such reference points or property monuments by professionally qualified personnel.

### 4.04 *Progress Schedule*

- A. Contractor shall adhere to the Progress Schedule established in accordance with Paragraph 2.05 as it may be adjusted from time to time as provided below.
  - 1. Contractor shall submit to Engineer for acceptance (to the extent indicated in Paragraph 2.05) proposed adjustments in the Progress Schedule that will not result in changing the Contract Times.

2. Proposed adjustments in the Progress Schedule that will change the Contract Times shall be submitted in accordance with the requirements of Article 11.
- B. Contractor shall carry on the Work and adhere to the Progress Schedule during all disputes or disagreements with Owner. No Work shall be delayed or postponed pending resolution of any disputes or disagreements, or during any appeal process, except as permitted by Paragraph 16.04, or as Owner and Contractor may otherwise agree in writing.
- 4.05 *Delays in Contractor's Progress*
- A. If Owner, Engineer, or anyone for whom Owner is responsible, delays, disrupts, or interferes with the performance or progress of the Work, then Contractor shall be entitled to an equitable adjustment in the Contract Times and Contract Price. Contractor's entitlement to an adjustment of the Contract Times is conditioned on such adjustment being essential to Contractor's ability to complete the Work within the Contract Times.
- B. Contractor shall not be entitled to an adjustment in Contract Price or Contract Times for delay, disruption, or interference caused by or within the control of Contractor. Delay, disruption, and interference attributable to and within the control of a Subcontractor or Supplier shall be deemed to be within the control of Contractor.
- C. If Contractor's performance or progress is delayed, disrupted, or interfered with by unanticipated causes not the fault of and beyond the control of Owner, Contractor, and those for which they are responsible, then Contractor shall be entitled to an equitable adjustment in Contract Times. Contractor's entitlement to an adjustment of the Contract Times is conditioned on such adjustment being essential to Contractor's ability to complete the Work within the Contract Times. Such an adjustment shall be Contractor's sole and exclusive remedy for the delays, disruption, and interference described in this paragraph. Causes of delay, disruption, or interference that may give rise to an adjustment in Contract Times under this paragraph include but are not limited to the following:
1. severe and unavoidable natural catastrophes such as fires, floods, epidemics, and earthquakes;
  2. abnormal weather conditions;
  3. acts or failures to act of utility owners (other than those performing other work at or adjacent to the Site by arrangement with the Owner, as contemplated in Article 8); and
  4. acts of war or terrorism.
- D. Delays, disruption, and interference to the performance or progress of the Work resulting from the existence of a differing subsurface or physical condition, an Underground Facility that was not shown or indicated by the Contract Documents, or not shown or indicated with reasonable accuracy, and those resulting from Hazardous Environmental Conditions, are governed by Article 5.
- E. Paragraph 8.03 governs delays, disruption, and interference to the performance or progress of the Work resulting from the performance of certain other work at or adjacent to the Site.
- F. Contractor shall not be entitled to an adjustment in Contract Price or Contract Times for any delay, disruption, or interference if such delay is concurrent with a delay, disruption, or interference caused by or within the control of Contractor.

- G. Contractor must submit any Change Proposal seeking an adjustment in Contract Price or Contract Times under this paragraph within 30 days of the commencement of the delaying, disrupting, or interfering event.

#### **ARTICLE 5 – AVAILABILITY OF LANDS; SUBSURFACE AND PHYSICAL CONDITIONS; HAZARDOUS ENVIRONMENTAL CONDITIONS**

##### **5.01 *Availability of Lands***

- A. Owner shall furnish the Site. Owner shall notify Contractor of any encumbrances or restrictions not of general application but specifically related to use of the Site with which Contractor must comply in performing the Work.
- B. Upon reasonable written request, Owner shall furnish Contractor with a current statement of record legal title and legal description of the lands upon which permanent improvements are to be made and Owner's interest therein as necessary for giving notice of or filing a mechanic's or construction lien against such lands in accordance with applicable Laws and Regulations.
- C. Contractor shall provide for all additional lands and access thereto that may be required for temporary construction facilities or storage of materials and equipment.

##### **5.02 *Use of Site and Other Areas***

- A. *Limitation on Use of Site and Other Areas:*
  - 1. Contractor shall confine construction equipment, temporary construction facilities, the storage of materials and equipment, and the operations of workers to the Site, adjacent areas that Contractor has arranged to use through construction easements or otherwise, and other adjacent areas permitted by Laws and Regulations, and shall not unreasonably encumber the Site and such other adjacent areas with construction equipment or other materials or equipment. Contractor shall assume full responsibility for (a) damage to the Site; (b) damage to any such other adjacent areas used for Contractor's operations; (c) damage to any other adjacent land or areas; and (d) for injuries and losses sustained by the owners or occupants of any such land or areas; provided that such damage or injuries result from the performance of the Work or from other actions or conduct of the Contractor or those for which Contractor is responsible.
  - 2. If a damage or injury claim is made by the owner or occupant of any such land or area because of the performance of the Work, or because of other actions or conduct of the Contractor or those for which Contractor is responsible, Contractor shall (a) take immediate corrective or remedial action as required by Paragraph 7.12, or otherwise; (b) promptly attempt to settle the claim as to all parties through negotiations with such owner or occupant, or otherwise resolve the claim by arbitration or other dispute resolution proceeding, or at law; and (c) to the fullest extent permitted by Laws and Regulations, indemnify and hold harmless Owner and Engineer, and the officers, directors, members, partners, employees, agents, consultants and subcontractors of each and any of them from and against any such claim, and against all costs, losses, and damages (including but not limited to all fees and charges of engineers, architects, attorneys, and other professionals and all court or arbitration or other dispute resolution costs) arising out of or relating to any claim or action, legal or equitable, brought by any such owner or occupant against Owner, Engineer, or any other party indemnified hereunder to the extent caused directly or indirectly, in whole or in part

by, or based upon, Contractor's performance of the Work, or because of other actions or conduct of the Contractor or those for which Contractor is responsible.

- B. *Removal of Debris During Performance of the Work:* During the progress of the Work the Contractor shall keep the Site and other adjacent areas free from accumulations of waste materials, rubbish, and other debris. Removal and disposal of such waste materials, rubbish, and other debris shall conform to applicable Laws and Regulations.
- C. *Cleaning:* Prior to Substantial Completion of the Work Contractor shall clean the Site and the Work and make it ready for utilization by Owner. At the completion of the Work Contractor shall remove from the Site and adjacent areas all tools, appliances, construction equipment and machinery, and surplus materials and shall restore to original condition all property not designated for alteration by the Contract Documents.
- D. *Loading of Structures:* Contractor shall not load nor permit any part of any structure to be loaded in any manner that will endanger the structure, nor shall Contractor subject any part of the Work or adjacent structures or land to stresses or pressures that will endanger them.

#### 5.03 *Subsurface and Physical Conditions*

- A. *Reports and Drawings:* The Supplementary Conditions identify:
  - 1. those reports known to Owner of explorations and tests of subsurface conditions at or adjacent to the Site;
  - 2. those drawings known to Owner of physical conditions relating to existing surface or subsurface structures at the Site (except Underground Facilities); and
  - 3. Technical Data contained in such reports and drawings.
- B. *Reliance by Contractor on Technical Data Authorized:* Contractor may rely upon the accuracy of the Technical Data expressly identified in the Supplementary Conditions with respect to such reports and drawings, but such reports and drawings are not Contract Documents. If no such express identification has been made, then Contractor may rely upon the accuracy of the Technical Data (as defined in Article 1) contained in any geotechnical or environmental report prepared for the Project and made available to Contractor. Except for such reliance on Technical Data, Contractor may not rely upon or make any claim against Owner or Engineer, or any of their officers, directors, members, partners, employees, agents, consultants, or subcontractors, with respect to:
  - 1. the completeness of such reports and drawings for Contractor's purposes, including, but not limited to, any aspects of the means, methods, techniques, sequences, and procedures of construction to be employed by Contractor, and safety precautions and programs incident thereto; or
  - 2. other data, interpretations, opinions, and information contained in such reports or shown or indicated in such drawings; or
  - 3. any Contractor interpretation of or conclusion drawn from any Technical Data or any such other data, interpretations, opinions, or information.

#### 5.04 *Differing Subsurface or Physical Conditions*

- A. *Notice by Contractor:* If Contractor believes that any subsurface or physical condition that is uncovered or revealed at the Site either:
1. is of such a nature as to establish that any Technical Data on which Contractor is entitled to rely as provided in Paragraph 5.03 is materially inaccurate; or
  2. is of such a nature as to require a change in the Drawings or Specifications; or
  3. differs materially from that shown or indicated in the Contract Documents; or
  4. is of an unusual nature, and differs materially from conditions ordinarily encountered and generally recognized as inherent in work of the character provided for in the Contract Documents;

then Contractor shall, promptly after becoming aware thereof and before further disturbing the subsurface or physical conditions or performing any Work in connection therewith (except in an emergency as required by Paragraph 7.15), notify Owner and Engineer in writing about such condition. Contractor shall not further disturb such condition or perform any Work in connection therewith (except with respect to an emergency) until receipt of a written statement permitting Contractor to do so.

- B. *Engineer's Review:* After receipt of written notice as required by the preceding paragraph, Engineer will promptly review the subsurface or physical condition in question; determine the necessity of Owner's obtaining additional exploration or tests with respect to the condition; conclude whether the condition falls within any one or more of the differing site condition categories in Paragraph 5.04.A above; obtain any pertinent cost or schedule information from Contractor; prepare recommendations to Owner regarding the Contractor's resumption of Work in connection with the subsurface or physical condition in question and the need for any change in the Drawings or Specifications; and advise Owner in writing of Engineer's findings, conclusions, and recommendations.
- C. *Owner's Statement to Contractor Regarding Site Condition:* After receipt of Engineer's written findings, conclusions, and recommendations, Owner shall issue a written statement to Contractor (with a copy to Engineer) regarding the subsurface or physical condition in question, addressing the resumption of Work in connection with such condition, indicating whether any change in the Drawings or Specifications will be made, and adopting or rejecting Engineer's written findings, conclusions, and recommendations, in whole or in part.
- D. *Possible Price and Times Adjustments:*
1. Contractor shall be entitled to an equitable adjustment in Contract Price or Contract Times, or both, to the extent that the existence of a differing subsurface or physical condition, or any related delay, disruption, or interference, causes an increase or decrease in Contractor's cost of, or time required for, performance of the Work; subject, however, to the following:
    - a. such condition must fall within any one or more of the categories described in Paragraph 5.04.A;
    - b. with respect to Work that is paid for on a unit price basis, any adjustment in Contract Price will be subject to the provisions of Paragraph 13.03; and,

- c. Contractor's entitlement to an adjustment of the Contract Times is conditioned on such adjustment being essential to Contractor's ability to complete the Work within the Contract Times.
2. Contractor shall not be entitled to any adjustment in the Contract Price or Contract Times with respect to a subsurface or physical condition if:
  - a. Contractor knew of the existence of such condition at the time Contractor made a commitment to Owner with respect to Contract Price and Contract Times by the submission of a Bid or becoming bound under a negotiated contract, or otherwise; or
  - b. the existence of such condition reasonably could have been discovered or revealed as a result of any examination, investigation, exploration, test, or study of the Site and contiguous areas expressly required by the Bidding Requirements or Contract Documents to be conducted by or for Contractor prior to Contractor's making such commitment; or
  - c. Contractor failed to give the written notice as required by Paragraph 5.04.A.
3. If Owner and Contractor agree regarding Contractor's entitlement to and the amount or extent of any adjustment in the Contract Price or Contract Times, or both, then any such adjustment shall be set forth in a Change Order.
4. Contractor may submit a Change Proposal regarding its entitlement to or the amount or extent of any adjustment in the Contract Price or Contract Times, or both, no later than 30 days after Owner's issuance of the Owner's written statement to Contractor regarding the subsurface or physical condition in question.

#### 5.05 *Underground Facilities*

- A. *Contractor's Responsibilities:* The information and data shown or indicated in the Contract Documents with respect to existing Underground Facilities at or adjacent to the Site is based on information and data furnished to Owner or Engineer by the owners of such Underground Facilities, including Owner, or by others. Unless it is otherwise expressly provided in the Supplementary Conditions:
  1. Owner and Engineer do not warrant or guarantee the accuracy or completeness of any such information or data provided by others; and
  2. the cost of all of the following will be included in the Contract Price, and Contractor shall have full responsibility for:
    - a. reviewing and checking all information and data regarding existing Underground Facilities at the Site;
    - b. locating all Underground Facilities shown or indicated in the Contract Documents as being at the Site;
    - c. coordination of the Work with the owners (including Owner) of such Underground Facilities, during construction; and
    - d. the safety and protection of all existing Underground Facilities at the Site, and repairing any damage thereto resulting from the Work.
- B. *Notice by Contractor:* If Contractor believes that an Underground Facility that is uncovered or revealed at the Site was not shown or indicated in the Contract Documents, or was not shown or indicated with reasonable accuracy, then Contractor shall, promptly after

becoming aware thereof and before further disturbing conditions affected thereby or performing any Work in connection therewith (except in an emergency as required by Paragraph 7.15), identify the owner of such Underground Facility and give written notice to that owner and to Owner and Engineer.

- C. *Engineer's Review:* Engineer will promptly review the Underground Facility and conclude whether such Underground Facility was not shown or indicated in the Contract Documents, or was not shown or indicated with reasonable accuracy; obtain any pertinent cost or schedule information from Contractor; prepare recommendations to Owner regarding the Contractor's resumption of Work in connection with the Underground Facility in question; determine the extent, if any, to which a change is required in the Drawings or Specifications to reflect and document the consequences of the existence or location of the Underground Facility; and advise Owner in writing of Engineer's findings, conclusions, and recommendations. During such time, Contractor shall be responsible for the safety and protection of such Underground Facility.
- D. *Owner's Statement to Contractor Regarding Underground Facility:* After receipt of Engineer's written findings, conclusions, and recommendations, Owner shall issue a written statement to Contractor (with a copy to Engineer) regarding the Underground Facility in question, addressing the resumption of Work in connection with such Underground Facility, indicating whether any change in the Drawings or Specifications will be made, and adopting or rejecting Engineer's written findings, conclusions, and recommendations in whole or in part.
- E. *Possible Price and Times Adjustments:*
  - 1. Contractor shall be entitled to an equitable adjustment in the Contract Price or Contract Times, or both, to the extent that any existing Underground Facility at the Site that was not shown or indicated in the Contract Documents, or was not shown or indicated with reasonable accuracy, or any related delay, disruption, or interference, causes an increase or decrease in Contractor's cost of, or time required for, performance of the Work; subject, however, to the following:
    - a. Contractor did not know of and could not reasonably have been expected to be aware of or to have anticipated the existence or actual location of the Underground Facility in question;
    - b. With respect to Work that is paid for on a unit price basis, any adjustment in Contract Price will be subject to the provisions of Paragraph 13.03;
    - c. Contractor's entitlement to an adjustment of the Contract Times is conditioned on such adjustment being essential to Contractor's ability to complete the Work within the Contract Times; and
    - d. Contractor gave the notice required in Paragraph 5.05.B.
  - 2. If Owner and Contractor agree regarding Contractor's entitlement to and the amount or extent of any adjustment in the Contract Price or Contract Times, or both, then any such adjustment shall be set forth in a Change Order.
  - 3. Contractor may submit a Change Proposal regarding its entitlement to or the amount or extent of any adjustment in the Contract Price or Contract Times, or both, no later than 30 days after Owner's issuance of the Owner's written statement to Contractor regarding the Underground Facility in question.

5.06 *Hazardous Environmental Conditions at Site*

- A. *Reports and Drawings:* The Supplementary Conditions identify:
1. those reports and drawings known to Owner relating to Hazardous Environmental Conditions that have been identified at or adjacent to the Site; and
  2. Technical Data contained in such reports and drawings.
- B. *Reliance by Contractor on Technical Data Authorized:* Contractor may rely upon the accuracy of the Technical Data expressly identified in the Supplementary Conditions with respect to such reports and drawings, but such reports and drawings are not Contract Documents. If no such express identification has been made, then Contractor may rely on the accuracy of the Technical Data (as defined in Article 1) contained in any geotechnical or environmental report prepared for the Project and made available to Contractor. Except for such reliance on Technical Data, Contractor may not rely upon or make any claim against Owner or Engineer, or any of their officers, directors, members, partners, employees, agents, consultants, or subcontractors with respect to:
1. the completeness of such reports and drawings for Contractor's purposes, including, but not limited to, any aspects of the means, methods, techniques, sequences and procedures of construction to be employed by Contractor and safety precautions and programs incident thereto; or
  2. other data, interpretations, opinions and information contained in such reports or shown or indicated in such drawings; or
  3. any Contractor interpretation of or conclusion drawn from any Technical Data or any such other data, interpretations, opinions or information.
- C. Contractor shall not be responsible for removing or remediating any Hazardous Environmental Condition encountered, uncovered, or revealed at the Site unless such removal or remediation is expressly identified in the Contract Documents to be within the scope of the Work.
- D. Contractor shall be responsible for controlling, containing, and duly removing all Constituents of Concern brought to the Site by Contractor, Subcontractors, Suppliers, or anyone else for whom Contractor is responsible, and for any associated costs; and for the costs of removing and remediating any Hazardous Environmental Condition created by the presence of any such Constituents of Concern.
- E. If Contractor encounters, uncovers, or reveals a Hazardous Environmental Condition whose removal or remediation is not expressly identified in the Contract Documents as being within the scope of the Work, or if Contractor or anyone for whom Contractor is responsible creates a Hazardous Environmental Condition, then Contractor shall immediately: (1) secure or otherwise isolate such condition; (2) stop all Work in connection with such condition and in any area affected thereby (except in an emergency as required by Paragraph 7.15); and (3) notify Owner and Engineer (and promptly thereafter confirm such notice in writing). Owner shall promptly consult with Engineer concerning the necessity for Owner to retain a qualified expert to evaluate such condition or take corrective action, if any. Promptly after consulting with Engineer, Owner shall take such actions as are necessary to permit Owner to timely obtain required permits and provide Contractor the written notice required by Paragraph 5.06.F. If Contractor or anyone for whom Contractor is responsible created the Hazardous Environmental Condition in question, then Owner may remove and remediate the Hazardous Environmental Condition, and impose a set-off against payments to account for the associated costs.

- F. Contractor shall not resume Work in connection with such Hazardous Environmental Condition or in any affected area until after Owner has obtained any required permits related thereto, and delivered written notice to Contractor either (1) specifying that such condition and any affected area is or has been rendered safe for the resumption of Work, or (2) specifying any special conditions under which such Work may be resumed safely.
- G. If Owner and Contractor cannot agree as to entitlement to or on the amount or extent, if any, of any adjustment in Contract Price or Contract Times, or both, as a result of such Work stoppage or such special conditions under which Work is agreed to be resumed by Contractor, then within 30 days of Owner's written notice regarding the resumption of Work, Contractor may submit a Change Proposal, or Owner may impose a set-off.
- H. If after receipt of such written notice Contractor does not agree to resume such Work based on a reasonable belief it is unsafe, or does not agree to resume such Work under such special conditions, then Owner may order the portion of the Work that is in the area affected by such condition to be deleted from the Work, following the contractual change procedures in Article 11. Owner may have such deleted portion of the Work performed by Owner's own forces or others in accordance with Article 8.
- I. To the fullest extent permitted by Laws and Regulations, Owner shall indemnify and hold harmless Contractor, Subcontractors, and Engineer, and the officers, directors, members, partners, employees, agents, consultants, and subcontractors of each and any of them from and against all claims, costs, losses, and damages (including but not limited to all fees and charges of engineers, architects, attorneys, and other professionals and all court or arbitration or other dispute resolution costs) arising out of or relating to a Hazardous Environmental Condition, provided that such Hazardous Environmental Condition (1) was not shown or indicated in the Drawings, Specifications, or other Contract Documents, identified as Technical Data entitled to limited reliance pursuant to Paragraph 5.06.B, or identified in the Contract Documents to be included within the scope of the Work, and (2) was not created by Contractor or by anyone for whom Contractor is responsible. Nothing in this Paragraph 5.06.H shall obligate Owner to indemnify any individual or entity from and against the consequences of that individual's or entity's own negligence.
- J. To the fullest extent permitted by Laws and Regulations, Contractor shall indemnify and hold harmless Owner and Engineer, and the officers, directors, members, partners, employees, agents, consultants, and subcontractors of each and any of them from and against all claims, costs, losses, and damages (including but not limited to all fees and charges of engineers, architects, attorneys, and other professionals and all court or arbitration or other dispute resolution costs) arising out of or relating to the failure to control, contain, or remove a Constituent of Concern brought to the Site by Contractor or by anyone for whom Contractor is responsible, or to a Hazardous Environmental Condition created by Contractor or by anyone for whom Contractor is responsible. Nothing in this Paragraph 5.06.J shall obligate Contractor to indemnify any individual or entity from and against the consequences of that individual's or entity's own negligence.
- K. The provisions of Paragraphs 5.03, 5.04, and 5.05 do not apply to the presence of Constituents of Concern or to a Hazardous Environmental Condition uncovered or revealed at the Site.

**ARTICLE 6 – BONDS AND INSURANCE****6.01 Performance, Payment, and Other Bonds**

- A. Contractor shall furnish a performance bond and a payment bond, each in an amount at least equal to the Contract Price, as security for the faithful performance and payment of all of Contractor's obligations under the Contract. These bonds shall remain in effect until one year after the date when final payment becomes due or until completion of the correction period specified in Paragraph 15.08, whichever is later, except as provided otherwise by Laws or Regulations, the Supplementary Conditions, or other specific provisions of the Contract. Contractor shall also furnish such other bonds as are required by the Supplementary Conditions or other specific provisions of the Contract.
- B. All bonds shall be in the form prescribed by the Contract except as provided otherwise by Laws or Regulations, and shall be executed by such sureties as are named in "Companies Holding Certificates of Authority as Acceptable Sureties on Federal Bonds and as Acceptable Reinsuring Companies" as published in Circular 570 (as amended and supplemented) by the Financial Management Service, Surety Bond Branch, U.S. Department of the Treasury. A bond signed by an agent or attorney-in-fact must be accompanied by a certified copy of that individual's authority to bind the surety. The evidence of authority shall show that it is effective on the date the agent or attorney-in-fact signed the accompanying bond.
- C. Contractor shall obtain the required bonds from surety companies that are duly licensed or authorized in the jurisdiction in which the Project is located to issue bonds in the required amounts.
- D. If the surety on a bond furnished by Contractor is declared bankrupt or becomes insolvent, or its right to do business is terminated in any state or jurisdiction where any part of the Project is located, or the surety ceases to meet the requirements above, then Contractor shall promptly notify Owner and Engineer and shall, within 20 days after the event giving rise to such notification, provide another bond and surety, both of which shall comply with the bond and surety requirements above.
- E. If Contractor has failed to obtain a required bond, Owner may exclude the Contractor from the Site and exercise Owner's termination rights under Article 16.
- F. Upon request, Owner shall provide a copy of the payment bond to any Subcontractor, Supplier, or other person or entity claiming to have furnished labor or materials used in the performance of the Work.

**6.02 Insurance—General Provisions**

- A. Owner and Contractor shall obtain and maintain insurance as required in this Article and in the Supplementary Conditions.
- B. All insurance required by the Contract to be purchased and maintained by Owner or Contractor shall be obtained from insurance companies that are duly licensed or authorized, in the state or jurisdiction in which the Project is located, to issue insurance policies for the required limits and coverages. Unless a different standard is indicated in the Supplementary Conditions, all companies that provide insurance policies required under this Contract shall have an A.M. Best rating of A-VII or better.
- C. Contractor shall deliver to Owner, with copies to each named insured and additional insured (as identified in this Article, in the Supplementary Conditions, or elsewhere in the Contract), certificates of insurance establishing that Contractor has obtained and is

maintaining the policies, coverages, and endorsements required by the Contract. Upon request by Owner or any other insured, Contractor shall also furnish other evidence of such required insurance, including but not limited to copies of policies and endorsements, and documentation of applicable self-insured retentions and deductibles. Contractor may block out (redact) any confidential premium or pricing information contained in any policy or endorsement furnished under this provision.

- D. Owner shall deliver to Contractor, with copies to each named insured and additional insured (as identified in this Article, the Supplementary Conditions, or elsewhere in the Contract), certificates of insurance establishing that Owner has obtained and is maintaining the policies, coverages, and endorsements required of Owner by the Contract (if any). Upon request by Contractor or any other insured, Owner shall also provide other evidence of such required insurance (if any), including but not limited to copies of policies and endorsements, and documentation of applicable self-insured retentions and deductibles. Owner may block out (redact) any confidential premium or pricing information contained in any policy or endorsement furnished under this provision.
- E. Failure of Owner or Contractor to demand such certificates or other evidence of the other party's full compliance with these insurance requirements, or failure of Owner or Contractor to identify a deficiency in compliance from the evidence provided, shall not be construed as a waiver of the other party's obligation to obtain and maintain such insurance.
- F. If either party does not purchase or maintain all of the insurance required of such party by the Contract, such party shall notify the other party in writing of such failure to purchase prior to the start of the Work, or of such failure to maintain prior to any change in the required coverage.
- G. If Contractor has failed to obtain and maintain required insurance, Owner may exclude the Contractor from the Site, impose an appropriate set-off against payment, and exercise Owner's termination rights under Article 16.
- H. Without prejudice to any other right or remedy, if a party has failed to obtain required insurance, the other party may elect to obtain equivalent insurance to protect such other party's interests at the expense of the party who was required to provide such coverage, and the Contract Price shall be adjusted accordingly.
- I. Owner does not represent that insurance coverage and limits established in this Contract necessarily will be adequate to protect Contractor or Contractor's interests.
- J. The insurance and insurance limits required herein shall not be deemed as a limitation on Contractor's liability under the indemnities granted to Owner and other individuals and entities in the Contract.

#### 6.03 *Contractor's Insurance*

- A. *Workers' Compensation:* Contractor shall purchase and maintain workers' compensation and employer's liability insurance for:
  - 1. claims under workers' compensation, disability benefits, and other similar employee benefit acts.
  - 2. United States Longshoreman and Harbor Workers' Compensation Act and Jones Act coverage (if applicable).
  - 3. claims for damages because of bodily injury, occupational sickness or disease, or death of Contractor's employees (by stop-gap endorsement in monopolist worker's compensation states).

4. Foreign voluntary worker compensation (if applicable).
- B. *Commercial General Liability—Claims Covered:* Contractor shall purchase and maintain commercial general liability insurance, covering all operations by or on behalf of Contractor, on an occurrence basis, against:
1. claims for damages because of bodily injury, sickness or disease, or death of any person other than Contractor's employees.
  2. claims for damages insured by reasonably available personal injury liability coverage.
  3. claims for damages, other than to the Work itself, because of injury to or destruction of tangible property wherever located, including loss of use resulting therefrom.
- C. *Commercial General Liability—Form and Content:* Contractor's commercial liability policy shall be written on a 1996 (or later) ISO commercial general liability form (occurrence form) and include the following coverages and endorsements:
1. Products and completed operations coverage:
    - a. Such insurance shall be maintained for three years after final payment.
    - b. Contractor shall furnish Owner and each other additional insured (as identified in the Supplementary Conditions or elsewhere in the Contract) evidence of continuation of such insurance at final payment and three years thereafter.
  2. Blanket contractual liability coverage, to the extent permitted by law, including but not limited to coverage of Contractor's contractual indemnity obligations in Paragraph 7.18.
  3. Broad form property damage coverage.
  4. Severability of interest.
  5. Underground, explosion, and collapse coverage.
  6. Personal injury coverage.
  7. Additional insured endorsements that include both ongoing operations and products and completed operations coverage through ISO Endorsements CG 20 10 10 01 and CG 20 37 10 01 (together); or CG 20 10 07 04 and CG 20 37 07 04 (together); or their equivalent.
  8. For design professional additional insureds, ISO Endorsement CG 20 32 07 04, "Additional Insured—Engineers, Architects or Surveyors Not Engaged by the Named Insured" or its equivalent.
- D. *Automobile liability:* Contractor shall purchase and maintain automobile liability insurance against claims for damages because of bodily injury or death of any person or property damage arising out of the ownership, maintenance, or use of any motor vehicle. The automobile liability policy shall be written on an occurrence basis.
- E. *Umbrella or excess liability:* Contractor shall purchase and maintain umbrella or excess liability insurance written over the underlying employer's liability, commercial general liability, and automobile liability insurance described in the paragraphs above. Subject to industry-standard exclusions, the coverage afforded shall follow form as to each and every one of the underlying policies.
- F. *Contractor's pollution liability insurance:* Contractor shall purchase and maintain a policy covering third-party injury and property damage claims, including clean-up costs, as a result

of pollution conditions arising from Contractor's operations and completed operations. This insurance shall be maintained for no less than three years after final completion.

- G. *Additional insureds*: The Contractor's commercial general liability, automobile liability, umbrella or excess, and pollution liability policies shall include and list as additional insureds Owner and Engineer, and any individuals or entities identified in the Supplementary Conditions; include coverage for the respective officers, directors, members, partners, employees, agents, consultants, and subcontractors of each and any of all such additional insureds; and the insurance afforded to these additional insureds shall provide primary coverage for all claims covered thereby (including as applicable those arising from both ongoing and completed operations) on a non-contributory basis. Contractor shall obtain all necessary endorsements to support these requirements.
- H. *Contractor's professional liability insurance*: If Contractor will provide or furnish professional services under this Contract, through a delegation of professional design services or otherwise, then Contractor shall be responsible for purchasing and maintaining applicable professional liability insurance. This insurance shall provide protection against claims arising out of performance of professional design or related services, and caused by a negligent error, omission, or act for which the insured party is legally liable. It shall be maintained throughout the duration of the Contract and for a minimum of two years after Substantial Completion. If such professional design services are performed by a Subcontractor, and not by Contractor itself, then the requirements of this paragraph may be satisfied through the purchasing and maintenance of such insurance by such Subcontractor.
- I. *General provisions*: The policies of insurance required by this Paragraph 6.03 shall:
1. include at least the specific coverages provided in this Article.
  2. be written for not less than the limits of liability provided in this Article and in the Supplementary Conditions, or required by Laws or Regulations, whichever is greater.
  3. contain a provision or endorsement that the coverage afforded will not be canceled, materially changed, or renewal refused until at least 10 days prior written notice has been given to Contractor. Within three days of receipt of any such written notice, Contractor shall provide a copy of the notice to Owner, Engineer, and each other insured under the policy.
  4. remain in effect at least until final payment (and longer if expressly required in this Article) and at all times thereafter when Contractor may be correcting, removing, or replacing defective Work as a warranty or correction obligation, or otherwise, or returning to the Site to conduct other tasks arising from the Contract Documents.
  5. be appropriate for the Work being performed and provide protection from claims that may arise out of or result from Contractor's performance of the Work and Contractor's other obligations under the Contract Documents, whether it is to be performed by Contractor, any Subcontractor or Supplier, or by anyone directly or indirectly employed by any of them to perform any of the Work, or by anyone for whose acts any of them may be liable.
- J. The coverage requirements for specific policies of insurance must be met by such policies, and not by reference to excess or umbrella insurance provided in other policies.

#### 6.04 *Owner's Liability Insurance*

- A. In addition to the insurance required to be provided by Contractor under Paragraph 6.03, Owner, at Owner's option, may purchase and maintain at Owner's expense Owner's own liability insurance as will protect Owner against claims which may arise from operations under the Contract Documents.
- B. Owner's liability policies, if any, operate separately and independently from policies required to be provided by Contractor, and Contractor cannot rely upon Owner's liability policies for any of Contractor's obligations to the Owner, Engineer, or third parties.

#### 6.05 *Property Insurance*

- A. *Builder's Risk*: Unless otherwise provided in the Supplementary Conditions, Contractor shall purchase and maintain builder's risk insurance upon the Work on a completed value basis, in the amount of the full insurable replacement cost thereof (subject to such deductible amounts as may be provided in the Supplementary Conditions or required by Laws and Regulations). This insurance shall:
  - 1. include the Owner and Contractor as named insureds, and all Subcontractors, and any individuals or entities required by the Supplementary Conditions to be insured under such builder's risk policy, as insureds or named insureds. For purposes of the remainder of this Paragraph 6.05, Paragraphs 6.06 and 6.07, and any corresponding Supplementary Conditions, the parties required to be insured shall collectively be referred to as "insureds."
  - 2. be written on a builder's risk "all risk" policy form that shall at least include insurance for physical loss or damage to the Work, temporary buildings, falsework, and materials and equipment in transit, and shall insure against at least the following perils or causes of loss: fire; lightning; windstorm; riot; civil commotion; terrorism; vehicle impact; aircraft; smoke; theft; vandalism and malicious mischief; mechanical breakdown, boiler explosion, and artificially generated electric current; earthquake; volcanic activity, and other earth movement; flood; collapse; explosion; debris removal; demolition occasioned by enforcement of Laws and Regulations; water damage (other than that caused by flood); and such other perils or causes of loss as may be specifically required by the Supplementary Conditions. If insurance against mechanical breakdown, boiler explosion, and artificially generated electric current; earthquake; volcanic activity, and other earth movement; or flood, are not commercially available under builder's risk policies, by endorsement or otherwise, such insurance may be provided through other insurance policies acceptable to Owner and Contractor.
  - 3. cover, as insured property, at least the following: (a) the Work and all materials, supplies, machinery, apparatus, equipment, fixtures, and other property of a similar nature that are to be incorporated into or used in the preparation, fabrication, construction, erection, or completion of the Work, including Owner-furnished or assigned property; (b) spare parts inventory required within the scope of the Contract; and (c) temporary works which are not intended to form part of the permanent constructed Work but which are intended to provide working access to the Site, or to the Work under construction, or which are intended to provide temporary support for the Work under construction, including scaffolding, form work, fences, shoring, falsework, and temporary structures.
  - 4. cover expenses incurred in the repair or replacement of any insured property (including but not limited to fees and charges of engineers and architects).

5. extend to cover damage or loss to insured property while in temporary storage at the Site or in a storage location outside the Site (but not including property stored at the premises of a manufacturer or Supplier).
  6. extend to cover damage or loss to insured property while in transit.
  7. allow for partial occupation or use of the Work by Owner, such that those portions of the Work that are not yet occupied or used by Owner shall remain covered by the builder's risk insurance.
  8. allow for the waiver of the insurer's subrogation rights, as set forth below.
  9. provide primary coverage for all losses and damages caused by the perils or causes of loss covered.
  10. not include a co-insurance clause.
  11. include an exception for ensuing losses from physical damage or loss with respect to any defective workmanship, design, or materials exclusions.
  12. include performance/hot testing and start-up.
  13. be maintained in effect, subject to the provisions herein regarding Substantial Completion and partial occupancy or use of the Work by Owner, until the Work is complete.
- B. *Notice of Cancellation or Change:* All the policies of insurance (and the certificates or other evidence thereof) required to be purchased and maintained in accordance with this Paragraph 6.05 will contain a provision or endorsement that the coverage afforded will not be canceled or materially changed or renewal refused until at least 10 days prior written notice has been given to the purchasing policyholder. Within three days of receipt of any such written notice, the purchasing policyholder shall provide a copy of the notice to each other insured.
- C. *Deductibles:* The purchaser of any required builder's risk or property insurance shall pay for costs not covered because of the application of a policy deductible.
- D. *Partial Occupancy or Use by Owner:* If Owner will occupy or use a portion or portions of the Work prior to Substantial Completion of all the Work as provided in Paragraph 15.04, then Owner (directly, if it is the purchaser of the builder's risk policy, or through Contractor) will provide notice of such occupancy or use to the builder's risk insurer. The builder's risk insurance shall not be canceled or permitted to lapse on account of any such partial use or occupancy; rather, those portions of the Work that are occupied or used by Owner may come off the builder's risk policy, while those portions of the Work not yet occupied or used by Owner shall remain covered by the builder's risk insurance.
- E. *Additional Insurance:* If Contractor elects to obtain other special insurance to be included in or supplement the builder's risk or property insurance policies provided under this Paragraph 6.05, it may do so at Contractor's expense.
- F. *Insurance of Other Property:* If the express insurance provisions of the Contract do not require or address the insurance of a property item or interest, such as tools, construction equipment, or other personal property owned by Contractor, a Subcontractor, or an employee of Contractor or a Subcontractor, then the entity or individual owning such property item will be responsible for deciding whether to insure it, and if so in what amount.

**6.06 Waiver of Rights**

- A. All policies purchased in accordance with Paragraph 6.05, expressly including the builder's risk policy, shall contain provisions to the effect that in the event of payment of any loss or damage the insurers will have no rights of recovery against any insureds thereunder, or against Engineer or its consultants, or their officers, directors, members, partners, employees, agents, consultants, or subcontractors. Owner and Contractor waive all rights against each other and the respective officers, directors, members, partners, employees, agents, consultants, and subcontractors of each and any of them, for all losses and damages caused by, arising out of, or resulting from any of the perils or causes of loss covered by such policies and any other property insurance applicable to the Work; and, in addition, waive all such rights against Engineer, its consultants, all Subcontractors, all individuals or entities identified in the Supplementary Conditions as insureds, and the officers, directors, members, partners, employees, agents, consultants, and subcontractors of each and any of them, under such policies for losses and damages so caused. None of the above waivers shall extend to the rights that any party making such waiver may have to the proceeds of insurance held by Owner or Contractor as trustee or fiduciary, or otherwise payable under any policy so issued.
- B. Owner waives all rights against Contractor, Subcontractors, and Engineer, and the officers, directors, members, partners, employees, agents, consultants and subcontractors of each and any of them, for:
  - 1. loss due to business interruption, loss of use, or other consequential loss extending beyond direct physical loss or damage to Owner's property or the Work caused by, arising out of, or resulting from fire or other perils whether or not insured by Owner; and
  - 2. loss or damage to the completed Project or part thereof caused by, arising out of, or resulting from fire or other insured peril or cause of loss covered by any property insurance maintained on the completed Project or part thereof by Owner during partial occupancy or use pursuant to Paragraph 15.04, after Substantial Completion pursuant to Paragraph 15.03, or after final payment pursuant to Paragraph 15.06.
- C. Any insurance policy maintained by Owner covering any loss, damage or consequential loss referred to in Paragraph 6.06.B shall contain provisions to the effect that in the event of payment of any such loss, damage, or consequential loss, the insurers will have no rights of recovery against Contractor, Subcontractors, or Engineer, or the officers, directors, members, partners, employees, agents, consultants, or subcontractors of each and any of them.
- D. Contractor shall be responsible for assuring that the agreement under which a Subcontractor performs a portion of the Work contains provisions whereby the Subcontractor waives all rights against Owner, Contractor, all individuals or entities identified in the Supplementary Conditions as insureds, the Engineer and its consultants, and the officers, directors, members, partners, employees, agents, consultants, and subcontractors of each and any of them, for all losses and damages caused by, arising out of, relating to, or resulting from any of the perils or causes of loss covered by builder's risk insurance and any other property insurance applicable to the Work.

**6.07 Receipt and Application of Property Insurance Proceeds**

- A. Any insured loss under the builder's risk and other policies of insurance required by Paragraph 6.05 will be adjusted and settled with the named insured that purchased the

policy. Such named insured shall act as fiduciary for the other insureds, and give notice to such other insureds that adjustment and settlement of a claim is in progress. Any other insured may state its position regarding a claim for insured loss in writing within 15 days after notice of such claim.

- B. Proceeds for such insured losses may be made payable by the insurer either jointly to multiple insureds, or to the named insured that purchased the policy in its own right and as fiduciary for other insureds, subject to the requirements of any applicable mortgage clause. A named insured receiving insurance proceeds under the builder's risk and other policies of insurance required by Paragraph 6.05 shall distribute such proceeds in accordance with such agreement as the parties in interest may reach, or as otherwise required under the dispute resolution provisions of this Contract or applicable Laws and Regulations.
- C. If no other special agreement is reached, the damaged Work shall be repaired or replaced, the money so received applied on account thereof, and the Work and the cost thereof covered by Change Order, if needed.

## ARTICLE 7 – CONTRACTOR'S RESPONSIBILITIES

### 7.01 *Supervision and Superintendence*

- A. Contractor shall supervise, inspect, and direct the Work competently and efficiently, devoting such attention thereto and applying such skills and expertise as may be necessary to perform the Work in accordance with the Contract Documents. Contractor shall be solely responsible for the means, methods, techniques, sequences, and procedures of construction.
- B. At all times during the progress of the Work, Contractor shall assign a competent resident superintendent who shall not be replaced without written notice to Owner and Engineer except under extraordinary circumstances.

### 7.02 *Labor; Working Hours*

- A. Contractor shall provide competent, suitably qualified personnel to survey and lay out the Work and perform construction as required by the Contract Documents. Contractor shall at all times maintain good discipline and order at the Site.
- B. Except as otherwise required for the safety or protection of persons or the Work or property at the Site or adjacent thereto, and except as otherwise stated in the Contract Documents, all Work at the Site shall be performed during regular working hours, Monday through Friday. Contractor will not perform Work on a Saturday, Sunday, or any legal holiday. Contractor may perform Work outside regular working hours or on Saturdays, Sundays, or legal holidays only with Owner's written consent, which will not be unreasonably withheld.

### 7.03 *Services, Materials, and Equipment*

- A. Unless otherwise specified in the Contract Documents, Contractor shall provide and assume full responsibility for all services, materials, equipment, labor, transportation, construction equipment and machinery, tools, appliances, fuel, power, light, heat, telephone, water, sanitary facilities, temporary facilities, and all other facilities and incidentals necessary for the performance, testing, start up, and completion of the Work, whether or not such items are specifically called for in the Contract Documents.
- B. All materials and equipment incorporated into the Work shall be of good quality and new, except as otherwise provided in the Contract Documents. All special warranties and

guarantees required by the Specifications shall expressly run to the benefit of Owner. If required by Engineer, Contractor shall furnish satisfactory evidence (including reports of required tests) as to the source, kind, and quality of materials and equipment.

- C. All materials and equipment shall be stored, applied, installed, connected, erected, protected, used, cleaned, and conditioned in accordance with instructions of the applicable Supplier, except as otherwise may be provided in the Contract Documents.

#### 7.04 "Or Equals"

- A. Whenever an item of material or equipment is specified or described in the Contract Documents by using the name of a proprietary item or the name of a particular Supplier, the Contract Price has been based upon Contractor furnishing such item as specified. The specification or description of such an item is intended to establish the type, function, appearance, and quality required. Unless the specification or description contains or is followed by words reading that no like, equivalent, or "or equal" item is permitted, Contractor may request that Engineer authorize the use of other items of material or equipment, or items from other proposed suppliers under the circumstances described below.
1. If Engineer in its sole discretion determines that an item of material or equipment proposed by Contractor is functionally equal to that named and sufficiently similar so that no change in related Work will be required, Engineer shall deem it an "or equal" item. For the purposes of this paragraph, a proposed item of material or equipment will be considered functionally equal to an item so named if:
    - a. in the exercise of reasonable judgment Engineer determines that:
      - 1) it is at least equal in materials of construction, quality, durability, appearance, strength, and design characteristics;
      - 2) it will reliably perform at least equally well the function and achieve the results imposed by the design concept of the completed Project as a functioning whole;
      - 3) it has a proven record of performance and availability of responsive service; and
      - 4) it is not objectionable to Owner.
    - b. Contractor certifies that, if approved and incorporated into the Work:
      - 1) there will be no increase in cost to the Owner or increase in Contract Times; and
      - 2) it will conform substantially to the detailed requirements of the item named in the Contract Documents.
- B. *Contractor's Expense:* Contractor shall provide all data in support of any proposed "or equal" item at Contractor's expense.
- C. *Engineer's Evaluation and Determination:* Engineer will be allowed a reasonable time to evaluate each "or-equal" request. Engineer may require Contractor to furnish additional data about the proposed "or-equal" item. Engineer will be the sole judge of acceptability. No "or-equal" item will be ordered, furnished, installed, or utilized until Engineer's review is complete and Engineer determines that the proposed item is an "or-equal", which will be evidenced by an approved Shop Drawing or other written communication. Engineer will advise Contractor in writing of any negative determination.

- D. *Effect of Engineer's Determination:* Neither approval nor denial of an "or-equal" request shall result in any change in Contract Price. The Engineer's denial of an "or-equal" request shall be final and binding, and may not be reversed through an appeal under any provision of the Contract Documents.
- E. *Treatment as a Substitution Request:* If Engineer determines that an item of material or equipment proposed by Contractor does not qualify as an "or-equal" item, Contractor may request that Engineer consider the proposed item as a substitute pursuant to Paragraph 7.05.

#### 7.05 Substitutes

- A. Unless the specification or description of an item of material or equipment required to be furnished under the Contract Documents contains or is followed by words reading that no substitution is permitted, Contractor may request that Engineer authorize the use of other items of material or equipment under the circumstances described below. To the extent possible such requests shall be made before commencement of related construction at the Site.
  - 1. Contractor shall submit sufficient information as provided below to allow Engineer to determine if the item of material or equipment proposed is functionally equivalent to that named and an acceptable substitute therefor. Engineer will not accept requests for review of proposed substitute items of material or equipment from anyone other than Contractor.
  - 2. The requirements for review by Engineer will be as set forth in Paragraph 7.05.B, as supplemented by the Specifications, and as Engineer may decide is appropriate under the circumstances.
  - 3. Contractor shall make written application to Engineer for review of a proposed substitute item of material or equipment that Contractor seeks to furnish or use. The application:
    - a. shall certify that the proposed substitute item will:
      - 1) perform adequately the functions and achieve the results called for by the general design,
      - 2) be similar in substance to that specified, and
      - 3) be suited to the same use as that specified.
    - b. will state:
      - 1) the extent, if any, to which the use of the proposed substitute item will necessitate a change in Contract Times,
      - 2) whether use of the proposed substitute item in the Work will require a change in any of the Contract Documents (or in the provisions of any other direct contract with Owner for other work on the Project) to adapt the design to the proposed substitute item, and
      - 3) whether incorporation or use of the proposed substitute item in connection with the Work is subject to payment of any license fee or royalty.
    - c. will identify:
      - 1) all variations of the proposed substitute item from that specified, and

- 2) available engineering, sales, maintenance, repair, and replacement services.
  - d. shall contain an itemized estimate of all costs or credits that will result directly or indirectly from use of such substitute item, including but not limited to changes in Contract Price, shared savings, costs of redesign, and claims of other contractors affected by any resulting change.
- B. *Engineer's Evaluation and Determination:* Engineer will be allowed a reasonable time to evaluate each substitute request, and to obtain comments and direction from Owner. Engineer may require Contractor to furnish additional data about the proposed substitute item. Engineer will be the sole judge of acceptability. No substitute will be ordered, furnished, installed, or utilized until Engineer's review is complete and Engineer determines that the proposed item is an acceptable substitute. Engineer's determination will be evidenced by a Field Order or a proposed Change Order accounting for the substitution itself and all related impacts, including changes in Contract Price or Contract Times. Engineer will advise Contractor in writing of any negative determination.
  - C. *Special Guarantee:* Owner may require Contractor to furnish at Contractor's expense a special performance guarantee or other surety with respect to any substitute.
  - D. *Reimbursement of Engineer's Cost:* Engineer will record Engineer's costs in evaluating a substitute proposed or submitted by Contractor. Whether or not Engineer approves a substitute so proposed or submitted by Contractor, Contractor shall reimburse Owner for the reasonable charges of Engineer for evaluating each such proposed substitute. Contractor shall also reimburse Owner for the reasonable charges of Engineer for making changes in the Contract Documents (or in the provisions of any other direct contract with Owner) resulting from the acceptance of each proposed substitute.
  - E. *Contractor's Expense:* Contractor shall provide all data in support of any proposed substitute at Contractor's expense.
  - F. *Effect of Engineer's Determination:* If Engineer approves the substitution request, Contractor shall execute the proposed Change Order and proceed with the substitution. The Engineer's denial of a substitution request shall be final and binding, and may not be reversed through an appeal under any provision of the Contract Documents. Contractor may challenge the scope of reimbursement costs imposed under Paragraph 7.05.D, by timely submittal of a Change Proposal.
- 7.06 *Concerning Subcontractors, Suppliers, and Others*
- A. Contractor may retain Subcontractors and Suppliers for the performance of parts of the Work. Such Subcontractors and Suppliers must be acceptable to Owner.
  - B. Contractor shall retain specific Subcontractors, Suppliers, or other individuals or entities for the performance of designated parts of the Work if required by the Contract to do so.
  - C. Subsequent to the submittal of Contractor's Bid or final negotiation of the terms of the Contract, Owner may not require Contractor to retain any Subcontractor, Supplier, or other individual or entity to furnish or perform any of the Work against which Contractor has reasonable objection.
  - D. Prior to entry into any binding subcontract or purchase order, Contractor shall submit to Owner the identity of the proposed Subcontractor or Supplier (unless Owner has already deemed such proposed Subcontractor or Supplier acceptable, during the bidding process or otherwise). Such proposed Subcontractor or Supplier shall be deemed acceptable to Owner unless Owner raises a substantive, reasonable objection within five days.

- E. Owner may require the replacement of any Subcontractor, Supplier, or other individual or entity retained by Contractor to perform any part of the Work. Owner also may require Contractor to retain specific replacements; provided, however, that Owner may not require a replacement to which Contractor has a reasonable objection. If Contractor has submitted the identity of certain Subcontractors, Suppliers, or other individuals or entities for acceptance by Owner, and Owner has accepted it (either in writing or by failing to make written objection thereto), then Owner may subsequently revoke the acceptance of any such Subcontractor, Supplier, or other individual or entity so identified solely on the basis of substantive, reasonable objection after due investigation. Contractor shall submit an acceptable replacement for the rejected Subcontractor, Supplier, or other individual or entity.
- F. If Owner requires the replacement of any Subcontractor, Supplier, or other individual or entity retained by Contractor to perform any part of the Work, then Contractor shall be entitled to an adjustment in Contract Price or Contract Times, or both, with respect to the replacement; and Contractor shall initiate a Change Proposal for such adjustment within 30 days of Owner's requirement of replacement.
- G. No acceptance by Owner of any such Subcontractor, Supplier, or other individual or entity, whether initially or as a replacement, shall constitute a waiver of the right of Owner to the completion of the Work in accordance with the Contract Documents.
- H. On a monthly basis Contractor shall submit to Engineer a complete list of all Subcontractors and Suppliers having a direct contract with Contractor, and of all other Subcontractors and Suppliers known to Contractor at the time of submittal.
- I. Contractor shall be fully responsible to Owner and Engineer for all acts and omissions of the Subcontractors, Suppliers, and other individuals or entities performing or furnishing any of the Work just as Contractor is responsible for Contractor's own acts and omissions.
- J. Contractor shall be solely responsible for scheduling and coordinating the work of Subcontractors, Suppliers, and all other individuals or entities performing or furnishing any of the Work.
- K. Contractor shall restrict all Subcontractors, Suppliers, and such other individuals or entities performing or furnishing any of the Work from communicating with Engineer or Owner, except through Contractor or in case of an emergency, or as otherwise expressly allowed herein.
- L. The divisions and sections of the Specifications and the identifications of any Drawings shall not control Contractor in dividing the Work among Subcontractors or Suppliers or delineating the Work to be performed by any specific trade.
- M. All Work performed for Contractor by a Subcontractor or Supplier shall be pursuant to an appropriate contractual agreement that specifically binds the Subcontractor or Supplier to the applicable terms and conditions of the Contract Documents for the benefit of Owner and Engineer.
- N. Owner may furnish to any Subcontractor or Supplier, to the extent practicable, information about amounts paid to Contractor on account of Work performed for Contractor by the particular Subcontractor or Supplier.

O. Nothing in the Contract Documents:

1. shall create for the benefit of any such Subcontractor, Supplier, or other individual or entity any contractual relationship between Owner or Engineer and any such Subcontractor, Supplier, or other individual or entity; nor
2. shall create any obligation on the part of Owner or Engineer to pay or to see to the payment of any money due any such Subcontractor, Supplier, or other individual or entity except as may otherwise be required by Laws and Regulations.

7.07 *Patent Fees and Royalties*

- A. Contractor shall pay all license fees and royalties and assume all costs incident to the use in the performance of the Work or the incorporation in the Work of any invention, design, process, product, or device which is the subject of patent rights or copyrights held by others. If a particular invention, design, process, product, or device is specified in the Contract Documents for use in the performance of the Work and if, to the actual knowledge of Owner or Engineer, its use is subject to patent rights or copyrights calling for the payment of any license fee or royalty to others, the existence of such rights shall be disclosed by Owner in the Contract Documents.
- B. To the fullest extent permitted by Laws and Regulations, Owner shall indemnify and hold harmless Contractor, and its officers, directors, members, partners, employees, agents, consultants, and subcontractors from and against all claims, costs, losses, and damages (including but not limited to all fees and charges of engineers, architects, attorneys, and other professionals, and all court or arbitration or other dispute resolution costs) arising out of or relating to any infringement of patent rights or copyrights incident to the use in the performance of the Work or resulting from the incorporation in the Work of any invention, design, process, product, or device specified in the Contract Documents, but not identified as being subject to payment of any license fee or royalty to others required by patent rights or copyrights.
- C. To the fullest extent permitted by Laws and Regulations, Contractor shall indemnify and hold harmless Owner and Engineer, and the officers, directors, members, partners, employees, agents, consultants and subcontractors of each and any of them from and against all claims, costs, losses, and damages (including but not limited to all fees and charges of engineers, architects, attorneys, and other professionals and all court or arbitration or other dispute resolution costs) arising out of or relating to any infringement of patent rights or copyrights incident to the use in the performance of the Work or resulting from the incorporation in the Work of any invention, design, process, product, or device not specified in the Contract Documents.

7.08 *Permits*

- A. Unless otherwise provided in the Contract Documents, Contractor shall obtain and pay for all construction permits and licenses. Owner shall assist Contractor, when necessary, in obtaining such permits and licenses. Contractor shall pay all governmental charges and inspection fees necessary for the prosecution of the Work which are applicable at the time of the submission of Contractor's Bid (or when Contractor became bound under a negotiated contract). Owner shall pay all charges of utility owners for connections for providing permanent service to the Work

#### 7.09 Taxes

- A. Contractor shall pay all sales, consumer, use, and other similar taxes required to be paid by Contractor in accordance with the Laws and Regulations of the place of the Project which are applicable during the performance of the Work.

#### 7.10 Laws and Regulations

- A. Contractor shall give all notices required by and shall comply with all Laws and Regulations applicable to the performance of the Work. Except where otherwise expressly required by applicable Laws and Regulations, neither Owner nor Engineer shall be responsible for monitoring Contractor's compliance with any Laws or Regulations.
- B. If Contractor performs any Work or takes any other action knowing or having reason to know that it is contrary to Laws or Regulations, Contractor shall bear all resulting costs and losses, and shall indemnify and hold harmless Owner and Engineer, and the officers, directors, members, partners, employees, agents, consultants, and subcontractors of each and any of them from and against all claims, costs, losses, and damages (including but not limited to all fees and charges of engineers, architects, attorneys, and other professionals and all court or arbitration or other dispute resolution costs) arising out of or relating to such Work or other action. It shall not be Contractor's responsibility to make certain that the Work described in the Contract Documents is in accordance with Laws and Regulations, but this shall not relieve Contractor of Contractor's obligations under Paragraph 3.03.
- C. Owner or Contractor may give notice to the other party of any changes after the submission of Contractor's Bid (or after the date when Contractor became bound under a negotiated contract) in Laws or Regulations having an effect on the cost or time of performance of the Work, including but not limited to changes in Laws or Regulations having an effect on procuring permits and on sales, use, value-added, consumption, and other similar taxes. If Owner and Contractor are unable to agree on entitlement to or on the amount or extent, if any, of any adjustment in Contract Price or Contract Times resulting from such changes, then within 30 days of such notice Contractor may submit a Change Proposal, or Owner may initiate a Claim.

#### 7.11 Record Documents

- A. Contractor shall maintain in a safe place at the Site one printed record copy of all Drawings, Specifications, Addenda, Change Orders, Work Change Directives, Field Orders, written interpretations and clarifications, and approved Shop Drawings. Contractor shall keep such record documents in good order and annotate them to show changes made during construction. These record documents, together with all approved Samples, will be available to Engineer for reference. Upon completion of the Work, Contractor shall deliver these record documents to Engineer.

#### 7.12 Safety and Protection

- A. Contractor shall be solely responsible for initiating, maintaining, and supervising all safety precautions and programs in connection with the Work. Such responsibility does not relieve Subcontractors of their responsibility for the safety of persons or property in the performance of their work, nor for compliance with applicable safety Laws and Regulations. Contractor shall take all necessary precautions for the safety of, and shall provide the necessary protection to prevent damage, injury, or loss to:
  - 1. all persons on the Site or who may be affected by the Work;

2. all the Work and materials and equipment to be incorporated therein, whether in storage on or off the Site; and
  3. other property at the Site or adjacent thereto, including trees, shrubs, lawns, walks, pavements, roadways, structures, other work in progress, utilities, and Underground Facilities not designated for removal, relocation, or replacement in the course of construction.
- B. Contractor shall comply with all applicable Laws and Regulations relating to the safety of persons or property, or to the protection of persons or property from damage, injury, or loss; and shall erect and maintain all necessary safeguards for such safety and protection. Contractor shall notify Owner; the owners of adjacent property, Underground Facilities, and other utilities; and other contractors and utility owners performing work at or adjacent to the Site, when prosecution of the Work may affect them, and shall cooperate with them in the protection, removal, relocation, and replacement of their property or work in progress.
  - C. Contractor shall comply with the applicable requirements of Owner's safety programs, if any. The Supplementary Conditions identify any Owner's safety programs that are applicable to the Work.
  - D. Contractor shall inform Owner and Engineer of the specific requirements of Contractor's safety program with which Owner's and Engineer's employees and representatives must comply while at the Site.
  - E. All damage, injury, or loss to any property referred to in Paragraph 7.12.A.2 or 7.12.A.3 caused, directly or indirectly, in whole or in part, by Contractor, any Subcontractor, Supplier, or any other individual or entity directly or indirectly employed by any of them to perform any of the Work, or anyone for whose acts any of them may be liable, shall be remedied by Contractor at its expense (except damage or loss attributable to the fault of Drawings or Specifications or to the acts or omissions of Owner or Engineer or anyone employed by any of them, or anyone for whose acts any of them may be liable, and not attributable, directly or indirectly, in whole or in part, to the fault or negligence of Contractor or any Subcontractor, Supplier, or other individual or entity directly or indirectly employed by any of them).
  - F. Contractor's duties and responsibilities for safety and protection shall continue until such time as all the Work is completed and Engineer has issued a notice to Owner and Contractor in accordance with Paragraph 15.06.B that the Work is acceptable (except as otherwise expressly provided in connection with Substantial Completion).
  - G. Contractor's duties and responsibilities for safety and protection shall resume whenever Contractor or any Subcontractor or Supplier returns to the Site to fulfill warranty or correction obligations, or to conduct other tasks arising from the Contract Documents.

#### 7.13 *Safety Representative*

- A. Contractor shall designate a qualified and experienced safety representative at the Site whose duties and responsibilities shall be the prevention of accidents and the maintaining and supervising of safety precautions and programs.

#### 7.14 *Hazard Communication Programs*

- A. Contractor shall be responsible for coordinating any exchange of material safety data sheets or other hazard communication information required to be made available to or

exchanged between or among employers at the Site in accordance with Laws or Regulations.

#### 7.15 *Emergencies*

- A. In emergencies affecting the safety or protection of persons or the Work or property at the Site or adjacent thereto, Contractor is obligated to act to prevent threatened damage, injury, or loss. Contractor shall give Engineer prompt written notice if Contractor believes that any significant changes in the Work or variations from the Contract Documents have been caused thereby or are required as a result thereof. If Engineer determines that a change in the Contract Documents is required because of the action taken by Contractor in response to such an emergency, a Work Change Directive or Change Order will be issued.

#### 7.16 *Shop Drawings, Samples, and Other Submittals*

A. *Shop Drawing and Sample Submittal Requirements:*

1. Before submitting a Shop Drawing or Sample, Contractor shall have:
  - a. reviewed and coordinated the Shop Drawing or Sample with other Shop Drawings and Samples and with the requirements of the Work and the Contract Documents;
  - b. determined and verified all field measurements, quantities, dimensions, specified performance and design criteria, installation requirements, materials, catalog numbers, and similar information with respect thereto;
  - c. determined and verified the suitability of all materials and equipment offered with respect to the indicated application, fabrication, shipping, handling, storage, assembly, and installation pertaining to the performance of the Work; and
  - d. determined and verified all information relative to Contractor's responsibilities for means, methods, techniques, sequences, and procedures of construction, and safety precautions and programs incident thereto.
2. Each submittal shall bear a stamp or specific written certification that Contractor has satisfied Contractor's obligations under the Contract Documents with respect to Contractor's review of that submittal, and that Contractor approves the submittal.
3. With each submittal, Contractor shall give Engineer specific written notice of any variations that the Shop Drawing or Sample may have from the requirements of the Contract Documents. This notice shall be set forth in a written communication separate from the Shop Drawings or Sample submittal; and, in addition, in the case of Shop Drawings by a specific notation made on each Shop Drawing submitted to Engineer for review and approval of each such variation.

- B. *Submittal Procedures for Shop Drawings and Samples:* Contractor shall submit Shop Drawings and Samples to Engineer for review and approval in accordance with the accepted Schedule of Submittals. Each submittal will be identified as Engineer may require.

1. *Shop Drawings:*

- a. Contractor shall submit the number of copies required in the Specifications.
- b. Data shown on the Shop Drawings will be complete with respect to quantities, dimensions, specified performance and design criteria, materials, and similar data to show Engineer the services, materials, and equipment Contractor proposes to

provide and to enable Engineer to review the information for the limited purposes required by Paragraph 7.16.D.

2. *Samples:*
    - a. Contractor shall submit the number of Samples required in the Specifications.
    - b. Contractor shall clearly identify each Sample as to material, Supplier, pertinent data such as catalog numbers, the use for which intended and other data as Engineer may require to enable Engineer to review the submittal for the limited purposes required by Paragraph 7.16.D.
  3. Where a Shop Drawing or Sample is required by the Contract Documents or the Schedule of Submittals, any related Work performed prior to Engineer's review and approval of the pertinent submittal will be at the sole expense and responsibility of Contractor.
- C. *Other Submittals:* Contractor shall submit other submittals to Engineer in accordance with the accepted Schedule of Submittals, and pursuant to the applicable terms of the Specifications.
- D. *Engineer's Review:*
1. Engineer will provide timely review of Shop Drawings and Samples in accordance with the Schedule of Submittals acceptable to Engineer. Engineer's review and approval will be only to determine if the items covered by the submittals will, after installation or incorporation in the Work, conform to the information given in the Contract Documents and be compatible with the design concept of the completed Project as a functioning whole as indicated by the Contract Documents.
  2. Engineer's review and approval will not extend to means, methods, techniques, sequences, or procedures of construction or to safety precautions or programs incident thereto.
  3. Engineer's review and approval of a separate item as such will not indicate approval of the assembly in which the item functions.
  4. Engineer's review and approval of a Shop Drawing or Sample shall not relieve Contractor from responsibility for any variation from the requirements of the Contract Documents unless Contractor has complied with the requirements of Paragraph 7.16.A.3 and Engineer has given written approval of each such variation by specific written notation thereof incorporated in or accompanying the Shop Drawing or Sample. Engineer will document any such approved variation from the requirements of the Contract Documents in a Field Order.
  5. Engineer's review and approval of a Shop Drawing or Sample shall not relieve Contractor from responsibility for complying with the requirements of Paragraph 7.16.A and B.
  6. Engineer's review and approval of a Shop Drawing or Sample, or of a variation from the requirements of the Contract Documents, shall not, under any circumstances, change the Contract Times or Contract Price, unless such changes are included in a Change Order.
  7. Neither Engineer's receipt, review, acceptance or approval of a Shop Drawing, Sample, or other submittal shall result in such item becoming a Contract Document.

8. Contractor shall perform the Work in compliance with the requirements and commitments set forth in approved Shop Drawings and Samples, subject to the provisions of Paragraph 7.16.D.4.

E. *Resubmittal Procedures:*

1. Contractor shall make corrections required by Engineer and shall return the required number of corrected copies of Shop Drawings and submit, as required, new Samples for review and approval. Contractor shall direct specific attention in writing to revisions other than the corrections called for by Engineer on previous submittals.
2. Contractor shall furnish required submittals with sufficient information and accuracy to obtain required approval of an item with no more than three submittals. Engineer will record Engineer's time for reviewing a fourth or subsequent submittal of a Shop Drawings, sample, or other item requiring approval, and Contractor shall be responsible for Engineer's charges to Owner for such time. Owner may impose a set-off against payments due to Contractor to secure reimbursement for such charges.
3. If Contractor requests a change of a previously approved submittal item, Contractor shall be responsible for Engineer's charges to Owner for its review time, and Owner may impose a set-off against payments due to Contractor to secure reimbursement for such charges, unless the need for such change is beyond the control of Contractor.

7.17 *Contractor's General Warranty and Guarantee*

- A. Contractor warrants and guarantees to Owner that all Work will be in accordance with the Contract Documents and will not be defective. Engineer and its officers, directors, members, partners, employees, agents, consultants, and subcontractors shall be entitled to rely on Contractor's warranty and guarantee.
- B. Contractor's warranty and guarantee hereunder excludes defects or damage caused by:
  1. abuse, modification, or improper maintenance or operation by persons other than Contractor, Subcontractors, Suppliers, or any other individual or entity for whom Contractor is responsible; or
  2. normal wear and tear under normal usage.
- C. Contractor's obligation to perform and complete the Work in accordance with the Contract Documents shall be absolute. None of the following will constitute an acceptance of Work that is not in accordance with the Contract Documents or a release of Contractor's obligation to perform the Work in accordance with the Contract Documents:
  1. observations by Engineer;
  2. recommendation by Engineer or payment by Owner of any progress or final payment;
  3. the issuance of a certificate of Substantial Completion by Engineer or any payment related thereto by Owner;
  4. use or occupancy of the Work or any part thereof by Owner;
  5. any review and approval of a Shop Drawing or Sample submittal;
  6. the issuance of a notice of acceptability by Engineer;
  7. any inspection, test, or approval by others; or
  8. any correction of defective Work by Owner.

- D. If the Contract requires the Contractor to accept the assignment of a contract entered into by Owner, then the specific warranties, guarantees, and correction obligations contained in the assigned contract shall govern with respect to Contractor's performance obligations to Owner for the Work described in the assigned contract.

#### 7.18 *Indemnification*

- A. To the fullest extent permitted by Laws and Regulations, and in addition to any other obligations of Contractor under the Contract or otherwise, Contractor shall indemnify and hold harmless Owner and Engineer, and the officers, directors, members, partners, employees, agents, consultants and subcontractors of each and any of them from and against all claims, costs, losses, and damages (including but not limited to all fees and charges of engineers, architects, attorneys, and other professionals and all court or arbitration or other dispute resolution costs) arising out of or relating to the performance of the Work, provided that any such claim, cost, loss, or damage is attributable to bodily injury, sickness, disease, or death, or to injury to or destruction of tangible property (other than the Work itself), including the loss of use resulting therefrom but only to the extent caused by any negligent act or omission of Contractor, any Subcontractor, any Supplier, or any individual or entity directly or indirectly employed by any of them to perform any of the Work or anyone for whose acts any of them may be liable.
- B. In any and all claims against Owner or Engineer or any of their officers, directors, members, partners, employees, agents, consultants, or subcontractors by any employee (or the survivor or personal representative of such employee) of Contractor, any Subcontractor, any Supplier, or any individual or entity directly or indirectly employed by any of them to perform any of the Work, or anyone for whose acts any of them may be liable, the indemnification obligation under Paragraph 7.18.A shall not be limited in any way by any limitation on the amount or type of damages, compensation, or benefits payable by or for Contractor or any such Subcontractor, Supplier, or other individual or entity under workers' compensation acts, disability benefit acts, or other employee benefit acts.
- C. The indemnification obligations of Contractor under Paragraph 7.18.A shall not extend to the liability of Engineer and Engineer's officers, directors, members, partners, employees, agents, consultants and subcontractors arising out of:
  - 1. the preparation or approval of, or the failure to prepare or approve maps, Drawings, opinions, reports, surveys, Change Orders, designs, or Specifications; or
  - 2. giving directions or instructions, or failing to give them, if that is the primary cause of the injury or damage.

#### 7.19 *Delegation of Professional Design Services*

- A. Contractor will not be required to provide professional design services unless such services are specifically required by the Contract Documents for a portion of the Work or unless such services are required to carry out Contractor's responsibilities for construction means, methods, techniques, sequences and procedures. Contractor shall not be required to provide professional services in violation of applicable Laws and Regulations.
- B. If professional design services or certifications by a design professional related to systems, materials, or equipment are specifically required of Contractor by the Contract Documents, Owner and Engineer will specify all performance and design criteria that such services must satisfy. Contractor shall cause such services or certifications to be provided by a properly licensed professional, whose signature and seal shall appear on all drawings, calculations, specifications, certifications, and other submittals prepared by such professional. Shop

Drawings and other submittals related to the Work designed or certified by such professional, if prepared by others, shall bear such professional's written approval when submitted to Engineer.

- C. Owner and Engineer shall be entitled to rely upon the adequacy, accuracy, and completeness of the services, certifications, or approvals performed by such design professionals, provided Owner and Engineer have specified to Contractor all performance and design criteria that such services must satisfy.
- D. Pursuant to this paragraph, Engineer's review and approval of design calculations and design drawings will be only for the limited purpose of checking for conformance with performance and design criteria given and the design concept expressed in the Contract Documents. Engineer's review and approval of Shop Drawings and other submittals (except design calculations and design drawings) will be only for the purpose stated in Paragraph 7.16.D.1.
- E. Contractor shall not be responsible for the adequacy of the performance or design criteria specified by Owner or Engineer.

#### ARTICLE 8 – OTHER WORK AT THE SITE

##### 8.01 *Other Work*

- A. In addition to and apart from the Work under the Contract Documents, the Owner may perform other work at or adjacent to the Site. Such other work may be performed by Owner's employees, or through contracts between the Owner and third parties. Owner may also arrange to have third-party utility owners perform work on their utilities and facilities at or adjacent to the Site.
- B. If Owner performs other work at or adjacent to the Site with Owner's employees, or through contracts for such other work, then Owner shall give Contractor written notice thereof prior to starting any such other work. If Owner has advance information regarding the start of any utility work at or adjacent to the Site, Owner shall provide such information to Contractor.
- C. Contractor shall afford each other contractor that performs such other work, each utility owner performing other work, and Owner, if Owner is performing other work with Owner's employees, proper and safe access to the Site, and provide a reasonable opportunity for the introduction and storage of materials and equipment and the execution of such other work. Contractor shall do all cutting, fitting, and patching of the Work that may be required to properly connect or otherwise make its several parts come together and properly integrate with such other work. Contractor shall not endanger any work of others by cutting, excavating, or otherwise altering such work; provided, however, that Contractor may cut or alter others' work with the written consent of Engineer and the others whose work will be affected.
- D. If the proper execution or results of any part of Contractor's Work depends upon work performed by others under this Article 8, Contractor shall inspect such other work and promptly report to Engineer in writing any delays, defects, or deficiencies in such other work that render it unavailable or unsuitable for the proper execution and results of Contractor's Work. Contractor's failure to so report will constitute an acceptance of such other work as fit and proper for integration with Contractor's Work except for latent defects and deficiencies in such other work.

### 8.02 *Coordination*

- A. If Owner intends to contract with others for the performance of other work at or adjacent to the Site, to perform other work at or adjacent to the Site with Owner's employees, or to arrange to have utility owners perform work at or adjacent to the Site, the following will be set forth in the Supplementary Conditions or provided to Contractor prior to the start of any such other work:
  - 1. the identity of the individual or entity that will have authority and responsibility for coordination of the activities among the various contractors;
  - 2. an itemization of the specific matters to be covered by such authority and responsibility; and
  - 3. the extent of such authority and responsibilities.
- B. Unless otherwise provided in the Supplementary Conditions, Owner shall have sole authority and responsibility for such coordination.

### 8.03 *Legal Relationships*

- A. If, in the course of performing other work at or adjacent to the Site for Owner, the Owner's employees, any other contractor working for Owner, or any utility owner causes damage to the Work or to the property of Contractor or its Subcontractors, or delays, disrupts, interferes with, or increases the scope or cost of the performance of the Work, through actions or inaction, then Contractor shall be entitled to an equitable adjustment in the Contract Price or the Contract Times, or both. Contractor must submit any Change Proposal seeking an equitable adjustment in the Contract Price or the Contract Times under this paragraph within 30 days of the damaging, delaying, disrupting, or interfering event. The entitlement to, and extent of, any such equitable adjustment shall take into account information (if any) regarding such other work that was provided to Contractor in the Contract Documents prior to the submittal of the Bid or the final negotiation of the terms of the Contract. When applicable, any such equitable adjustment in Contract Price shall be conditioned on Contractor assigning to Owner all Contractor's rights against such other contractor or utility owner with respect to the damage, delay, disruption, or interference that is the subject of the adjustment. Contractor's entitlement to an adjustment of the Contract Times is conditioned on such adjustment being essential to Contractor's ability to complete the Work within the Contract Times.
- B. Contractor shall take reasonable and customary measures to avoid damaging, delaying, disrupting, or interfering with the work of Owner, any other contractor, or any utility owner performing other work at or adjacent to the Site. If Contractor fails to take such measures and as a result damages, delays, disrupts, or interferes with the work of any such other contractor or utility owner, then Owner may impose a set-off against payments due to Contractor, and assign to such other contractor or utility owner the Owner's contractual rights against Contractor with respect to the breach of the obligations set forth in this paragraph.
- C. When Owner is performing other work at or adjacent to the Site with Owner's employees, Contractor shall be liable to Owner for damage to such other work, and for the reasonable direct delay, disruption, and interference costs incurred by Owner as a result of Contractor's failure to take reasonable and customary measures with respect to Owner's other work. In response to such damage, delay, disruption, or interference, Owner may impose a set-off against payments due to Contractor.

- D. If Contractor damages, delays, disrupts, or interferes with the work of any other contractor, or any utility owner performing other work at or adjacent to the Site, through Contractor's failure to take reasonable and customary measures to avoid such impacts, or if any claim arising out of Contractor's actions, inactions, or negligence in performance of the Work at or adjacent to the Site is made by any such other contractor or utility owner against Contractor, Owner, or Engineer, then Contractor shall (1) promptly attempt to settle the claim as to all parties through negotiations with such other contractor or utility owner, or otherwise resolve the claim by arbitration or other dispute resolution proceeding or at law, and (2) indemnify and hold harmless Owner and Engineer, and the officers, directors, members, partners, employees, agents, consultants and subcontractors of each and any of them from and against any such claims, and against all costs, losses, and damages (including but not limited to all fees and charges of engineers, architects, attorneys, and other professionals and all court or arbitration or other dispute resolution costs) arising out of or relating to such damage, delay, disruption, or interference.

## ARTICLE 9 – OWNER'S RESPONSIBILITIES

### 9.01 *Communications to Contractor*

- A. Except as otherwise provided in these General Conditions, Owner shall issue all communications to Contractor through Engineer.

### 9.02 *Replacement of Engineer*

- A. Owner may at its discretion appoint an engineer to replace Engineer, provided Contractor makes no reasonable objection to the replacement engineer. The replacement engineer's status under the Contract Documents shall be that of the former Engineer.

### 9.03 *Furnish Data*

- A. Owner shall promptly furnish the data required of Owner under the Contract Documents.

### 9.04 *Pay When Due*

- A. Owner shall make payments to Contractor when they are due as provided in the Agreement.

### 9.05 *Lands and Easements; Reports, Tests, and Drawings*

- A. Owner's duties with respect to providing lands and easements are set forth in Paragraph 5.01.
- B. Owner's duties with respect to providing engineering surveys to establish reference points are set forth in Paragraph 4.03.
- C. Article 5 refers to Owner's identifying and making available to Contractor copies of reports of explorations and tests of conditions at the Site, and drawings of physical conditions relating to existing surface or subsurface structures at the Site.

### 9.06 *Insurance*

- A. Owner's responsibilities, if any, with respect to purchasing and maintaining liability and property insurance are set forth in Article 6.

### 9.07 *Change Orders*

- A. Owner's responsibilities with respect to Change Orders are set forth in Article 11.

**9.08** *Inspections, Tests, and Approvals*

- A. Owner's responsibility with respect to certain inspections, tests, and approvals is set forth in Paragraph 14.02.B.

**9.09** *Limitations on Owner's Responsibilities*

- A. The Owner shall not supervise, direct, or have control or authority over, nor be responsible for, Contractor's means, methods, techniques, sequences, or procedures of construction, or the safety precautions and programs incident thereto, or for any failure of Contractor to comply with Laws and Regulations applicable to the performance of the Work. Owner will not be responsible for Contractor's failure to perform the Work in accordance with the Contract Documents.

**9.10** *Undisclosed Hazardous Environmental Condition*

- A. Owner's responsibility in respect to an undisclosed Hazardous Environmental Condition is set forth in Paragraph 5.06.

**9.11** *Evidence of Financial Arrangements*

- A. Upon request of Contractor, Owner shall furnish Contractor reasonable evidence that financial arrangements have been made to satisfy Owner's obligations under the Contract Documents (including obligations under proposed changes in the Work).

**9.12** *Safety Programs*

- A. While at the Site, Owner's employees and representatives shall comply with the specific applicable requirements of Contractor's safety programs of which Owner has been informed.
- B. Owner shall furnish copies of any applicable Owner safety programs to Contractor.

**ARTICLE 10 – ENGINEER'S STATUS DURING CONSTRUCTION****10.01** *Owner's Representative*

- A. Engineer will be Owner's representative during the construction period. The duties and responsibilities and the limitations of authority of Engineer as Owner's representative during construction are set forth in the Contract.

**10.02** *Visits to Site*

- A. Engineer will make visits to the Site at intervals appropriate to the various stages of construction as Engineer deems necessary in order to observe as an experienced and qualified design professional the progress that has been made and the quality of the various aspects of Contractor's executed Work. Based on information obtained during such visits and observations, Engineer, for the benefit of Owner, will determine, in general, if the Work is proceeding in accordance with the Contract Documents. Engineer will not be required to make exhaustive or continuous inspections on the Site to check the quality or quantity of the Work. Engineer's efforts will be directed toward providing for Owner a greater degree of confidence that the completed Work will conform generally to the Contract Documents. On the basis of such visits and observations, Engineer will keep Owner informed of the progress of the Work and will endeavor to guard Owner against defective Work.
- B. Engineer's visits and observations are subject to all the limitations on Engineer's authority and responsibility set forth in Paragraph 10.08. Particularly, but without limitation, during

or as a result of Engineer's visits or observations of Contractor's Work, Engineer will not supervise, direct, control, or have authority over or be responsible for Contractor's means, methods, techniques, sequences, or procedures of construction, or the safety precautions and programs incident thereto, or for any failure of Contractor to comply with Laws and Regulations applicable to the performance of the Work.

**10.03 *Project Representative***

- A. If Owner and Engineer have agreed that Engineer will furnish a Resident Project Representative to represent Engineer at the Site and assist Engineer in observing the progress and quality of the Work, then the authority and responsibilities of any such Resident Project Representative will be as provided in the Supplementary Conditions, and limitations on the responsibilities thereof will be as provided in Paragraph 10.08. If Owner designates another representative or agent to represent Owner at the Site who is not Engineer's consultant, agent, or employee, the responsibilities and authority and limitations thereon of such other individual or entity will be as provided in the Supplementary Conditions.

**10.04 *Rejecting Defective Work***

- A. Engineer has the authority to reject Work in accordance with Article 14.

**10.05 *Shop Drawings, Change Orders and Payments***

- A. Engineer's authority, and limitations thereof, as to Shop Drawings and Samples, are set forth in Paragraph 7.16.
- B. Engineer's authority, and limitations thereof, as to design calculations and design drawings submitted in response to a delegation of professional design services, if any, are set forth in Paragraph 7.19.
- C. Engineer's authority as to Change Orders is set forth in Article 11.
- D. Engineer's authority as to Applications for Payment is set forth in Article 15.

**10.06 *Determinations for Unit Price Work***

- A. Engineer will determine the actual quantities and classifications of Unit Price Work performed by Contractor as set forth in Paragraph 13.03.

**10.07 *Decisions on Requirements of Contract Documents and Acceptability of Work***

- A. Engineer will render decisions regarding the requirements of the Contract Documents, and judge the acceptability of the Work, pursuant to the specific procedures set forth herein for initial interpretations, Change Proposals, and acceptance of the Work. In rendering such decisions and judgments, Engineer will not show partiality to Owner or Contractor, and will not be liable to Owner, Contractor, or others in connection with any proceedings, interpretations, decisions, or judgments conducted or rendered in good faith.

**10.08 *Limitations on Engineer's Authority and Responsibilities***

- A. Neither Engineer's authority or responsibility under this Article 10 or under any other provision of the Contract, nor any decision made by Engineer in good faith either to exercise or not exercise such authority or responsibility or the undertaking, exercise, or performance of any authority or responsibility by Engineer, shall create, impose, or give rise to any duty in contract, tort, or otherwise owed by Engineer to Contractor, any Subcontractor, any Supplier, any other individual or entity, or to any surety for or employee or agent of any of them.

- B. Engineer will not supervise, direct, control, or have authority over or be responsible for Contractor's means, methods, techniques, sequences, or procedures of construction, or the safety precautions and programs incident thereto, or for any failure of Contractor to comply with Laws and Regulations applicable to the performance of the Work. Engineer will not be responsible for Contractor's failure to perform the Work in accordance with the Contract Documents.
- C. Engineer will not be responsible for the acts or omissions of Contractor or of any Subcontractor, any Supplier, or of any other individual or entity performing any of the Work.
- D. Engineer's review of the final Application for Payment and accompanying documentation and all maintenance and operating instructions, schedules, guarantees, bonds, certificates of inspection, tests and approvals, and other documentation required to be delivered by Paragraph 15.06.A will only be to determine generally that their content complies with the requirements of, and in the case of certificates of inspections, tests, and approvals, that the results certified indicate compliance with the Contract Documents.
- E. The limitations upon authority and responsibility set forth in this Paragraph 10.08 shall also apply to the Resident Project Representative, if any.

10.09 *Compliance with Safety Program*

- A. While at the Site, Engineer's employees and representatives will comply with the specific applicable requirements of Owner's and Contractor's safety programs (if any) of which Engineer has been informed.

**ARTICLE 11 – AMENDING THE CONTRACT DOCUMENTS; CHANGES IN THE WORK**

11.01 *Amending and Supplementing Contract Documents*

- A. The Contract Documents may be amended or supplemented by a Change Order, a Work Change Directive, or a Field Order.
  - 1. *Change Orders:*
    - a. If an amendment or supplement to the Contract Documents includes a change in the Contract Price or the Contract Times, such amendment or supplement must be set forth in a Change Order. A Change Order also may be used to establish amendments and supplements of the Contract Documents that do not affect the Contract Price or Contract Times.
    - b. Owner and Contractor may amend those terms and conditions of the Contract Documents that do not involve (1) the performance or acceptability of the Work, (2) the design (as set forth in the Drawings, Specifications, or otherwise), or (3) other engineering or technical matters, without the recommendation of the Engineer. Such an amendment shall be set forth in a Change Order.
  - 2. *Work Change Directives:* A Work Change Directive will not change the Contract Price or the Contract Times but is evidence that the parties expect that the modification ordered or documented by a Work Change Directive will be incorporated in a subsequently issued Change Order, following negotiations by the parties as to the Work Change Directive's effect, if any, on the Contract Price and Contract Times; or, if negotiations are unsuccessful, by a determination under the terms of the Contract Documents governing adjustments, expressly including Paragraph 11.04 regarding change of Contract Price. Contractor must submit any Change Proposal seeking an

adjustment of the Contract Price or the Contract Times, or both, no later than 30 days after the completion of the Work set out in the Work Change Directive. Owner must submit any Claim seeking an adjustment of the Contract Price or the Contract Times, or both, no later than 60 days after issuance of the Work Change Directive.

3. *Field Orders*: Engineer may authorize minor changes in the Work if the changes do not involve an adjustment in the Contract Price or the Contract Times and are compatible with the design concept of the completed Project as a functioning whole as indicated by the Contract Documents. Such changes will be accomplished by a Field Order and will be binding on Owner and also on Contractor, which shall perform the Work involved promptly. If Contractor believes that a Field Order justifies an adjustment in the Contract Price or Contract Times, or both, then before proceeding with the Work at issue, Contractor shall submit a Change Proposal as provided herein.

#### 11.02 *Owner-Authorized Changes in the Work*

- A. Without invalidating the Contract and without notice to any surety, Owner may, at any time or from time to time, order additions, deletions, or revisions in the Work. Such changes shall be supported by Engineer's recommendation, to the extent the change involves the design (as set forth in the Drawings, Specifications, or otherwise), or other engineering or technical matters. Such changes may be accomplished by a Change Order, if Owner and Contractor have agreed as to the effect, if any, of the changes on Contract Times or Contract Price; or by a Work Change Directive. Upon receipt of any such document, Contractor shall promptly proceed with the Work involved; or, in the case of a deletion in the Work, promptly cease construction activities with respect to such deleted Work. Added or revised Work shall be performed under the applicable conditions of the Contract Documents. Nothing in this paragraph shall obligate Contractor to undertake work that Contractor reasonably concludes cannot be performed in a manner consistent with Contractor's safety obligations under the Contract Documents or Laws and Regulations.

#### 11.03 *Unauthorized Changes in the Work*

- A. Contractor shall not be entitled to an increase in the Contract Price or an extension of the Contract Times with respect to any work performed that is not required by the Contract Documents, as amended, modified, or supplemented, except in the case of an emergency as provided in Paragraph 7.15 or in the case of uncovering Work as provided in Paragraph 14.05.

#### 11.04 *Change of Contract Price*

- A. The Contract Price may only be changed by a Change Order. Any Change Proposal for an adjustment in the Contract Price shall comply with the provisions of Paragraph 11.06. Any Claim for an adjustment of Contract Price shall comply with the provisions of Article 12.
- B. An adjustment in the Contract Price will be determined as follows:
  1. where the Work involved is covered by unit prices contained in the Contract Documents, then by application of such unit prices to the quantities of the items involved (subject to the provisions of Paragraph 13.03); or
  2. where the Work involved is not covered by unit prices contained in the Contract Documents, then by a mutually agreed lump sum (which may include an allowance for overhead and profit not necessarily in accordance with Paragraph 11.04.C.2); or
  3. where the Work involved is not covered by unit prices contained in the Contract Documents and the parties do not reach mutual agreement to a lump sum, then on

the basis of the Cost of the Work (determined as provided in Paragraph 13.01) plus a Contractor's fee for overhead and profit (determined as provided in Paragraph 11.04.C).

- C. *Contractor's Fee:* When applicable, the Contractor's fee for overhead and profit shall be determined as follows:
1. a mutually acceptable fixed fee; or
  2. if a fixed fee is not agreed upon, then a fee based on the following percentages of the various portions of the Cost of the Work:
    - a. for costs incurred under Paragraphs 13.01.B.1 and 13.01.B.2, the Contractor's fee shall be 15 percent;
    - b. for costs incurred under Paragraph 13.01.B.3, the Contractor's fee shall be five percent;
    - c. where one or more tiers of subcontracts are on the basis of Cost of the Work plus a fee and no fixed fee is agreed upon, the intent of Paragraphs 11.01.C.2.a and 11.01.C.2.b is that the Contractor's fee shall be based on: (1) a fee of 15 percent of the costs incurred under Paragraphs 13.01.A.1 and 13.01.A.2 by the Subcontractor that actually performs the Work, at whatever tier, and (2) with respect to Contractor itself and to any Subcontractors of a tier higher than that of the Subcontractor that actually performs the Work, a fee of five percent of the amount (fee plus underlying costs incurred) attributable to the next lower tier Subcontractor; provided, however, that for any such subcontracted work the maximum total fee to be paid by Owner shall be no greater than 27 percent of the costs incurred by the Subcontractor that actually performs the work;
    - d. no fee shall be payable on the basis of costs itemized under Paragraphs 13.01.B.4, 13.01.B.5, and 13.01.C;
    - e. the amount of credit to be allowed by Contractor to Owner for any change which results in a net decrease in cost will be the amount of the actual net decrease in cost plus a deduction in Contractor's fee by an amount equal to five percent of such net decrease; and
    - f. when both additions and credits are involved in any one change, the adjustment in Contractor's fee shall be computed on the basis of the net change in accordance with Paragraphs 11.04.C.2.a through 11.04.C.2.e, inclusive.

#### 11.05 *Change of Contract Times*

- A. The Contract Times may only be changed by a Change Order. Any Change Proposal for an adjustment in the Contract Times shall comply with the provisions of Paragraph 11.06. Any Claim for an adjustment in the Contract Times shall comply with the provisions of Article 12.
- B. An adjustment of the Contract Times shall be subject to the limitations set forth in Paragraph 4.05, concerning delays in Contractor's progress.

#### 11.06 *Change Proposals*

- A. Contractor shall submit a Change Proposal to Engineer to request an adjustment in the Contract Times or Contract Price; appeal an initial decision by Engineer concerning the requirements of the Contract Documents or relating to the acceptability of the Work under the Contract Documents; contest a set-off against payment due; or seek other relief under

the Contract. The Change Proposal shall specify any proposed change in Contract Times or Contract Price, or both, or other proposed relief, and explain the reason for the proposed change, with citations to any governing or applicable provisions of the Contract Documents.

1. *Procedures:* Contractor shall submit each Change Proposal to Engineer promptly (but in no event later than 30 days) after the start of the event giving rise thereto, or after such initial decision. The Contractor shall submit supporting data, including the proposed change in Contract Price or Contract Time (if any), to the Engineer and Owner within 15 days after the submittal of the Change Proposal. The supporting data shall be accompanied by a written statement that the supporting data are accurate and complete, and that any requested time or price adjustment is the entire adjustment to which Contractor believes it is entitled as a result of said event. Engineer will advise Owner regarding the Change Proposal, and consider any comments or response from Owner regarding the Change Proposal.
  2. *Engineer's Action:* Engineer will review each Change Proposal and, within 30 days after receipt of the Contractor's supporting data, either deny the Change Proposal in whole, approve it in whole, or deny it in part and approve it in part. Such actions shall be in writing, with a copy provided to Owner and Contractor. If Engineer does not take action on the Change Proposal within 30 days, then either Owner or Contractor may at any time thereafter submit a letter to the other party indicating that as a result of Engineer's inaction the Change Proposal is deemed denied, thereby commencing the time for appeal of the denial under Article 12.
  3. *Binding Decision:* Engineer's decision will be final and binding upon Owner and Contractor, unless Owner or Contractor appeals the decision by filing a Claim under Article 12.
- B. *Resolution of Certain Change Proposals:* If the Change Proposal does not involve the design (as set forth in the Drawings, Specifications, or otherwise), the acceptability of the Work, or other engineering or technical matters, then Engineer will notify the parties that the Engineer is unable to resolve the Change Proposal. For purposes of further resolution of such a Change Proposal, such notice shall be deemed a denial, and Contractor may choose to seek resolution under the terms of Article 12.

#### 11.07 Execution of Change Orders

- A. Owner and Contractor shall execute appropriate Change Orders covering:
1. changes in the Contract Price or Contract Times which are agreed to by the parties, including any undisputed sum or amount of time for Work actually performed in accordance with a Work Change Directive;
  2. changes in Contract Price resulting from an Owner set-off, unless Contractor has duly contested such set-off;
  3. changes in the Work which are: (a) ordered by Owner pursuant to Paragraph 11.02, (b) required because of Owner's acceptance of defective Work under Paragraph 14.04 or Owner's correction of defective Work under Paragraph 14.07, or (c) agreed to by the parties, subject to the need for Engineer's recommendation if the change in the Work involves the design (as set forth in the Drawings, Specifications, or otherwise), or other engineering or technical matters; and
  4. changes in the Contract Price or Contract Times, or other changes, which embody the substance of any final and binding results under Paragraph 11.06, or Article 12.

- B. If Owner or Contractor refuses to execute a Change Order that is required to be executed under the terms of this Paragraph 11.07, it shall be deemed to be of full force and effect, as if fully executed.

#### 11.08 *Notification to Surety*

- A. If the provisions of any bond require notice to be given to a surety of any change affecting the general scope of the Work or the provisions of the Contract Documents (including, but not limited to, Contract Price or Contract Times), the giving of any such notice will be Contractor's responsibility. The amount of each applicable bond will be adjusted to reflect the effect of any such change.

### ARTICLE 12 – CLAIMS

#### 12.01 *Claims*

- A. *Claims Process:* The following disputes between Owner and Contractor shall be submitted to the Claims process set forth in this Article:
  - 1. Appeals by Owner or Contractor of Engineer's decisions regarding Change Proposals;
  - 2. Owner demands for adjustments in the Contract Price or Contract Times, or other relief under the Contract Documents; and
  - 3. Disputes that Engineer has been unable to address because they do not involve the design (as set forth in the Drawings, Specifications, or otherwise), the acceptability of the Work, or other engineering or technical matters.
- B. *Submittal of Claim:* The party submitting a Claim shall deliver it directly to the other party to the Contract promptly (but in no event later than 30 days) after the start of the event giving rise thereto; in the case of appeals regarding Change Proposals within 30 days of the decision under appeal. The party submitting the Claim shall also furnish a copy to the Engineer, for its information only. The responsibility to substantiate a Claim shall rest with the party making the Claim. In the case of a Claim by Contractor seeking an increase in the Contract Times or Contract Price, or both, Contractor shall certify that the Claim is made in good faith, that the supporting data are accurate and complete, and that to the best of Contractor's knowledge and belief the amount of time or money requested accurately reflects the full amount to which Contractor is entitled.
- C. *Review and Resolution:* The party receiving a Claim shall review it thoroughly, giving full consideration to its merits. The two parties shall seek to resolve the Claim through the exchange of information and direct negotiations. The parties may extend the time for resolving the Claim by mutual agreement. All actions taken on a Claim shall be stated in writing and submitted to the other party, with a copy to Engineer.
- D. *Mediation:*
  - 1. At any time after initiation of a Claim, Owner and Contractor may mutually agree to mediation of the underlying dispute. The agreement to mediate shall stay the Claim submittal and response process.
  - 2. If Owner and Contractor agree to mediation, then after 60 days from such agreement, either Owner or Contractor may unilaterally terminate the mediation process, and the Claim submittal and decision process shall resume as of the date of the termination. If the mediation proceeds but is unsuccessful in resolving the dispute, the Claim

submittal and decision process shall resume as of the date of the conclusion of the mediation, as determined by the mediator.

3. Owner and Contractor shall each pay one-half of the mediator's fees and costs.
- E. *Partial Approval*: If the party receiving a Claim approves the Claim in part and denies it in part, such action shall be final and binding unless within 30 days of such action the other party invokes the procedure set forth in Article 17 for final resolution of disputes.
- F. *Denial of Claim*: If efforts to resolve a Claim are not successful, the party receiving the Claim may deny it by giving written notice of denial to the other party. If the receiving party does not take action on the Claim within 90 days, then either Owner or Contractor may at any time thereafter submit a letter to the other party indicating that as a result of the inaction, the Claim is deemed denied, thereby commencing the time for appeal of the denial. A denial of the Claim shall be final and binding unless within 30 days of the denial the other party invokes the procedure set forth in Article 17 for the final resolution of disputes.
- G. *Final and Binding Results*: If the parties reach a mutual agreement regarding a Claim, whether through approval of the Claim, direct negotiations, mediation, or otherwise; or if a Claim is approved in part and denied in part, or denied in full, and such actions become final and binding; then the results of the agreement or action on the Claim shall be incorporated in a Change Order to the extent they affect the Contract, including the Work, the Contract Times, or the Contract Price.

#### ARTICLE 13 – COST OF THE WORK; ALLOWANCES; UNIT PRICE WORK

##### 13.01 *Cost of the Work*

- A. *Purposes for Determination of Cost of the Work*: The term Cost of the Work means the sum of all costs necessary for the proper performance of the Work at issue, as further defined below. The provisions of this Paragraph 13.01 are used for two distinct purposes:
  1. To determine Cost of the Work when Cost of the Work is a component of the Contract Price, under cost-plus-fee, time-and-materials, or other cost-based terms; or
  2. To determine the value of a Change Order, Change Proposal, Claim, set-off, or other adjustment in Contract Price. When the value of any such adjustment is determined on the basis of Cost of the Work, Contractor is entitled only to those additional or incremental costs required because of the change in the Work or because of the event giving rise to the adjustment.
- B. *Costs Included*: Except as otherwise may be agreed to in writing by Owner, costs included in the Cost of the Work shall be in amounts no higher than those prevailing in the locality of the Project, shall not include any of the costs itemized in Paragraph 13.01.C, and shall include only the following items:
  1. Payroll costs for employees in the direct employ of Contractor in the performance of the Work under schedules of job classifications agreed upon by Owner and Contractor. Such employees shall include, without limitation, superintendents, foremen, and other personnel employed full time on the Work. Payroll costs for employees not employed full time on the Work shall be apportioned on the basis of their time spent on the Work. Payroll costs shall include, but not be limited to, salaries and wages plus the cost of fringe benefits, which shall include social security contributions, unemployment, excise, and payroll taxes, workers' compensation, health and retirement benefits, bonuses, sick leave, and vacation and holiday pay applicable

thereto. The expenses of performing Work outside of regular working hours, on Saturday, Sunday, or legal holidays, shall be included in the above to the extent authorized by Owner.

2. Cost of all materials and equipment furnished and incorporated in the Work, including costs of transportation and storage thereof, and Suppliers' field services required in connection therewith. All cash discounts shall accrue to Contractor unless Owner deposits funds with Contractor with which to make payments, in which case the cash discounts shall accrue to Owner. All trade discounts, rebates, and refunds and returns from sale of surplus materials and equipment shall accrue to Owner, and Contractor shall make provisions so that they may be obtained.
3. Payments made by Contractor to Subcontractors for Work performed by Subcontractors. If required by Owner, Contractor shall obtain competitive bids from subcontractors acceptable to Owner and Contractor and shall deliver such bids to Owner, who will then determine, with the advice of Engineer, which bids, if any, will be acceptable. If any subcontract provides that the Subcontractor is to be paid on the basis of Cost of the Work plus a fee, the Subcontractor's Cost of the Work and fee shall be determined in the same manner as Contractor's Cost of the Work and fee as provided in this Paragraph 13.01.
4. Costs of special consultants (including but not limited to engineers, architects, testing laboratories, surveyors, attorneys, and accountants) employed for services specifically related to the Work.
5. Supplemental costs including the following:
  - a. The proportion of necessary transportation, travel, and subsistence expenses of Contractor's employees incurred in discharge of duties connected with the Work.
  - b. Cost, including transportation and maintenance, of all materials, supplies, equipment, machinery, appliances, office, and temporary facilities at the Site, and hand tools not owned by the workers, which are consumed in the performance of the Work, and cost, less market value, of such items used but not consumed which remain the property of Contractor.
  - c. Rentals of all construction equipment and machinery, and the parts thereof, whether rented from Contractor or others in accordance with rental agreements approved by Owner with the advice of Engineer, and the costs of transportation, loading, unloading, assembly, dismantling, and removal thereof. All such costs shall be in accordance with the terms of said rental agreements. The rental of any such equipment, machinery, or parts shall cease when the use thereof is no longer necessary for the Work.
  - d. Sales, consumer, use, and other similar taxes related to the Work, and for which Contractor is liable, as imposed by Laws and Regulations.
  - e. Deposits lost for causes other than negligence of Contractor, any Subcontractor, or anyone directly or indirectly employed by any of them or for whose acts any of them may be liable, and royalty payments and fees for permits and licenses.
  - f. Losses and damages (and related expenses) caused by damage to the Work, not compensated by insurance or otherwise, sustained by Contractor in connection with the performance of the Work (except losses and damages within the deductible amounts of property insurance established in accordance with Paragraph 6.05), provided such losses and damages have resulted from causes

other than the negligence of Contractor, any Subcontractor, or anyone directly or indirectly employed by any of them or for whose acts any of them may be liable. Such losses shall include settlements made with the written consent and approval of Owner. No such losses, damages, and expenses shall be included in the Cost of the Work for the purpose of determining Contractor's fee.

- g. The cost of utilities, fuel, and sanitary facilities at the Site.
- h. Minor expenses such as communication service at the Site, express and courier services, and similar petty cash items in connection with the Work.
- i. The costs of premiums for all bonds and insurance that Contractor is required by the Contract Documents to purchase and maintain.

C. *Costs Excluded:* The term Cost of the Work shall not include any of the following items:

- 1. Payroll costs and other compensation of Contractor's officers, executives, principals (of partnerships and sole proprietorships), general managers, safety managers, engineers, architects, estimators, attorneys, auditors, accountants, purchasing and contracting agents, expeditors, timekeepers, clerks, and other personnel employed by Contractor, whether at the Site or in Contractor's principal or branch office for general administration of the Work and not specifically included in the agreed upon schedule of job classifications referred to in Paragraph 13.01.B.1 or specifically covered by Paragraph 13.01.B.4. The payroll costs and other compensation excluded here are to be considered administrative costs covered by the Contractor's fee.
- 2. Expenses of Contractor's principal and branch offices other than Contractor's office at the Site.
- 3. Any part of Contractor's capital expenses, including interest on Contractor's capital employed for the Work and charges against Contractor for delinquent payments.
- 4. Costs due to the negligence of Contractor, any Subcontractor, or anyone directly or indirectly employed by any of them or for whose acts any of them may be liable, including but not limited to, the correction of defective Work, disposal of materials or equipment wrongly supplied, and making good any damage to property.
- 5. Other overhead or general expense costs of any kind and the costs of any item not specifically and expressly included in Paragraph 13.01.B.

D. *Contractor's Fee:* When the Work as a whole is performed on the basis of cost-plus, Contractor's fee shall be determined as set forth in the Agreement. When the value of any Work covered by a Change Order, Change Proposal, Claim, set-off, or other adjustment in Contract Price is determined on the basis of Cost of the Work, Contractor's fee shall be determined as set forth in Paragraph 11.04.C.

E. *Documentation:* Whenever the Cost of the Work for any purpose is to be determined pursuant to this Article 13, Contractor will establish and maintain records thereof in accordance with generally accepted accounting practices and submit in a form acceptable to Engineer an itemized cost breakdown together with supporting data.

### 13.02 Allowances

- A. It is understood that Contractor has included in the Contract Price all allowances so named in the Contract Documents and shall cause the Work so covered to be performed for such sums and by such persons or entities as may be acceptable to Owner and Engineer.

- B. *Cash Allowances*: Contractor agrees that:
  - 1. the cash allowances include the cost to Contractor (less any applicable trade discounts) of materials and equipment required by the allowances to be delivered at the Site, and all applicable taxes; and
  - 2. Contractor's costs for unloading and handling on the Site, labor, installation, overhead, profit, and other expenses contemplated for the cash allowances have been included in the Contract Price and not in the allowances, and no demand for additional payment on account of any of the foregoing will be valid.
- C. *Contingency Allowance*: Contractor agrees that a contingency allowance, if any, is for the sole use of Owner to cover unanticipated costs.
- D. Prior to final payment, an appropriate Change Order will be issued as recommended by Engineer to reflect actual amounts due Contractor on account of Work covered by allowances, and the Contract Price shall be correspondingly adjusted.

### 13.03 *Unit Price Work*

- A. Where the Contract Documents provide that all or part of the Work is to be Unit Price Work, initially the Contract Price will be deemed to include for all Unit Price Work an amount equal to the sum of the unit price for each separately identified item of Unit Price Work times the estimated quantity of each item as indicated in the Agreement.
- B. The estimated quantities of items of Unit Price Work are not guaranteed and are solely for the purpose of comparison of Bids and determining an initial Contract Price. Payments to Contractor for Unit Price Work will be based on actual quantities.
- C. Each unit price will be deemed to include an amount considered by Contractor to be adequate to cover Contractor's overhead and profit for each separately identified item.
- D. Engineer will determine the actual quantities and classifications of Unit Price Work performed by Contractor. Engineer will review with Contractor the Engineer's preliminary determinations on such matters before rendering a written decision thereon (by recommendation of an Application for Payment or otherwise). Engineer's written decision thereon will be final and binding (except as modified by Engineer to reflect changed factual conditions or more accurate data) upon Owner and Contractor, subject to the provisions of the following paragraph.
- E. Within 30 days of Engineer's written decision under the preceding paragraph, Contractor may submit a Change Proposal, or Owner may file a Claim, seeking an adjustment in the Contract Price if:
  - 1. the quantity of any item of Unit Price Work performed by Contractor differs materially and significantly from the estimated quantity of such item indicated in the Agreement;
  - 2. there is no corresponding adjustment with respect to any other item of Work; and
  - 3. Contractor believes that it is entitled to an increase in Contract Price as a result of having incurred additional expense or Owner believes that Owner is entitled to a decrease in Contract Price, and the parties are unable to agree as to the amount of any such increase or decrease.

**ARTICLE 14 – TESTS AND INSPECTIONS; CORRECTION, REMOVAL OR ACCEPTANCE OF DEFECTIVE WORK****14.01 Access to Work**

- A. Owner, Engineer, their consultants and other representatives and personnel of Owner, independent testing laboratories, and authorities having jurisdiction will have access to the Site and the Work at reasonable times for their observation, inspection, and testing. Contractor shall provide them proper and safe conditions for such access and advise them of Contractor's safety procedures and programs so that they may comply therewith as applicable.

**14.02 Tests, Inspections, and Approvals**

- A. Contractor shall give Engineer timely notice of readiness of the Work (or specific parts thereof) for all required inspections and tests, and shall cooperate with inspection and testing personnel to facilitate required inspections and tests.
- B. Owner shall retain and pay for the services of an independent inspector, testing laboratory, or other qualified individual or entity to perform all inspections and tests expressly required by the Contract Documents to be furnished and paid for by Owner, except that costs incurred in connection with tests or inspections of covered Work shall be governed by the provisions of Paragraph 14.05.
- C. If Laws or Regulations of any public body having jurisdiction require any Work (or part thereof) specifically to be inspected, tested, or approved by an employee or other representative of such public body, Contractor shall assume full responsibility for arranging and obtaining such inspections, tests, or approvals, pay all costs in connection therewith, and furnish Engineer the required certificates of inspection or approval.
- D. Contractor shall be responsible for arranging, obtaining, and paying for all inspections and tests required:
1. by the Contract Documents, unless the Contract Documents expressly allocate responsibility for a specific inspection or test to Owner;
  2. to attain Owner's and Engineer's acceptance of materials or equipment to be incorporated in the Work;
  3. by manufacturers of equipment furnished under the Contract Documents;
  4. for testing, adjusting, and balancing of mechanical, electrical, and other equipment to be incorporated into the Work; and
  5. for acceptance of materials, mix designs, or equipment submitted for approval prior to Contractor's purchase thereof for incorporation in the Work.

Such inspections and tests shall be performed by independent inspectors, testing laboratories, or other qualified individuals or entities acceptable to Owner and Engineer.

- E. If the Contract Documents require the Work (or part thereof) to be approved by Owner, Engineer, or another designated individual or entity, then Contractor shall assume full responsibility for arranging and obtaining such approvals.
- F. If any Work (or the work of others) that is to be inspected, tested, or approved is covered by Contractor without written concurrence of Engineer, Contractor shall, if requested by Engineer, uncover such Work for observation. Such uncovering shall be at Contractor's expense unless Contractor had given Engineer timely notice of Contractor's intention to

cover the same and Engineer had not acted with reasonable promptness in response to such notice.

#### 14.03 *Defective Work*

- A. *Contractor's Obligation:* It is Contractor's obligation to assure that the Work is not defective.
- B. *Engineer's Authority:* Engineer has the authority to determine whether Work is defective, and to reject defective Work.
- C. *Notice of Defects:* Prompt notice of all defective Work of which Owner or Engineer has actual knowledge will be given to Contractor.
- D. *Correction, or Removal and Replacement:* Promptly after receipt of written notice of defective Work, Contractor shall correct all such defective Work, whether or not fabricated, installed, or completed, or, if Engineer has rejected the defective Work, remove it from the Project and replace it with Work that is not defective.
- E. *Preservation of Warranties:* When correcting defective Work, Contractor shall take no action that would void or otherwise impair Owner's special warranty and guarantee, if any, on said Work.
- F. *Costs and Damages:* In addition to its correction, removal, and replacement obligations with respect to defective Work, Contractor shall pay all claims, costs, losses, and damages arising out of or relating to defective Work, including but not limited to the cost of the inspection, testing, correction, removal, replacement, or reconstruction of such defective Work, fines levied against Owner by governmental authorities because the Work is defective, and the costs of repair or replacement of work of others resulting from defective Work. Prior to final payment, if Owner and Contractor are unable to agree as to the measure of such claims, costs, losses, and damages resulting from defective Work, then Owner may impose a reasonable set-off against payments due under Article 15.

#### 14.04 *Acceptance of Defective Work*

- A. If, instead of requiring correction or removal and replacement of defective Work, Owner prefers to accept it, Owner may do so (subject, if such acceptance occurs prior to final payment, to Engineer's confirmation that such acceptance is in general accord with the design intent and applicable engineering principles, and will not endanger public safety). Contractor shall pay all claims, costs, losses, and damages attributable to Owner's evaluation of and determination to accept such defective Work (such costs to be approved by Engineer as to reasonableness), and for the diminished value of the Work to the extent not otherwise paid by Contractor. If any such acceptance occurs prior to final payment, the necessary revisions in the Contract Documents with respect to the Work shall be incorporated in a Change Order. If the parties are unable to agree as to the decrease in the Contract Price, reflecting the diminished value of Work so accepted, then Owner may impose a reasonable set-off against payments due under Article 15. If the acceptance of defective Work occurs after final payment, Contractor shall pay an appropriate amount to Owner.

#### 14.05 *Uncovering Work*

- A. Engineer has the authority to require special inspection or testing of the Work, whether or not the Work is fabricated, installed, or completed.

- B. If any Work is covered contrary to the written request of Engineer, then Contractor shall, if requested by Engineer, uncover such Work for Engineer's observation, and then replace the covering, all at Contractor's expense.
- C. If Engineer considers it necessary or advisable that covered Work be observed by Engineer or inspected or tested by others, then Contractor, at Engineer's request, shall uncover, expose, or otherwise make available for observation, inspection, or testing as Engineer may require, that portion of the Work in question, and provide all necessary labor, material, and equipment.
  - 1. If it is found that the uncovered Work is defective, Contractor shall be responsible for all claims, costs, losses, and damages arising out of or relating to such uncovering, exposure, observation, inspection, and testing, and of satisfactory replacement or reconstruction (including but not limited to all costs of repair or replacement of work of others); and pending Contractor's full discharge of this responsibility the Owner shall be entitled to impose a reasonable set-off against payments due under Article 15.
  - 2. If the uncovered Work is not found to be defective, Contractor shall be allowed an increase in the Contract Price or an extension of the Contract Times, or both, directly attributable to such uncovering, exposure, observation, inspection, testing, replacement, and reconstruction. If the parties are unable to agree as to the amount or extent thereof, then Contractor may submit a Change Proposal within 30 days of the determination that the Work is not defective.

#### 14.06 *Owner May Stop the Work*

- A. If the Work is defective, or Contractor fails to supply sufficient skilled workers or suitable materials or equipment, or fails to perform the Work in such a way that the completed Work will conform to the Contract Documents, then Owner may order Contractor to stop the Work, or any portion thereof, until the cause for such order has been eliminated; however, this right of Owner to stop the Work shall not give rise to any duty on the part of Owner to exercise this right for the benefit of Contractor, any Subcontractor, any Supplier, any other individual or entity, or any surety for, or employee or agent of any of them.

#### 14.07 *Owner May Correct Defective Work*

- A. If Contractor fails within a reasonable time after written notice from Engineer to correct defective Work, or to remove and replace rejected Work as required by Engineer, or if Contractor fails to perform the Work in accordance with the Contract Documents, or if Contractor fails to comply with any other provision of the Contract Documents, then Owner may, after seven days written notice to Contractor, correct or remedy any such deficiency.
- B. In exercising the rights and remedies under this Paragraph 14.07, Owner shall proceed expeditiously. In connection with such corrective or remedial action, Owner may exclude Contractor from all or part of the Site, take possession of all or part of the Work and suspend Contractor's services related thereto, and incorporate in the Work all materials and equipment stored at the Site or for which Owner has paid Contractor but which are stored elsewhere. Contractor shall allow Owner, Owner's representatives, agents and employees, Owner's other contractors, and Engineer and Engineer's consultants access to the Site to enable Owner to exercise the rights and remedies under this paragraph.
- C. All claims, costs, losses, and damages incurred or sustained by Owner in exercising the rights and remedies under this Paragraph 14.07 will be charged against Contractor as set-offs against payments due under Article 15. Such claims, costs, losses and damages will

include but not be limited to all costs of repair, or replacement of work of others destroyed or damaged by correction, removal, or replacement of Contractor's defective Work.

- D. Contractor shall not be allowed an extension of the Contract Times because of any delay in the performance of the Work attributable to the exercise by Owner of Owner's rights and remedies under this Paragraph 14.07.

## ARTICLE 15 – PAYMENTS TO CONTRACTOR; SET-OFFS; COMPLETION; CORRECTION PERIOD

### 15.01 *Progress Payments*

- A. *Basis for Progress Payments:* The Schedule of Values established as provided in Article 2 will serve as the basis for progress payments and will be incorporated into a form of Application for Payment acceptable to Engineer. Progress payments on account of Unit Price Work will be based on the number of units completed during the pay period, as determined under the provisions of Paragraph 13.03. Progress payments for cost-based Work will be based on Cost of the Work completed by Contractor during the pay period.
- B. *Applications for Payments:*
1. At least 20 days before the date established in the Agreement for each progress payment (but not more often than once a month), Contractor shall submit to Engineer for review an Application for Payment filled out and signed by Contractor covering the Work completed as of the date of the Application and accompanied by such supporting documentation as is required by the Contract Documents. If payment is requested on the basis of materials and equipment not incorporated in the Work but delivered and suitably stored at the Site or at another location agreed to in writing, the Application for Payment shall also be accompanied by a bill of sale, invoice, or other documentation warranting that Owner has received the materials and equipment free and clear of all Liens, and evidence that the materials and equipment are covered by appropriate property insurance, a warehouse bond, or other arrangements to protect Owner's interest therein, all of which must be satisfactory to Owner.
  2. Beginning with the second Application for Payment, each Application shall include an affidavit of Contractor stating that all previous progress payments received on account of the Work have been applied on account to discharge Contractor's legitimate obligations associated with prior Applications for Payment.
  3. The amount of retainage with respect to progress payments will be as stipulated in the Agreement.
- C. *Review of Applications:*
1. Engineer will, within 10 days after receipt of each Application for Payment, including each resubmittal, either indicate in writing a recommendation of payment and present the Application to Owner, or return the Application to Contractor indicating in writing Engineer's reasons for refusing to recommend payment. In the latter case, Contractor may make the necessary corrections and resubmit the Application.
  2. Engineer's recommendation of any payment requested in an Application for Payment will constitute a representation by Engineer to Owner, based on Engineer's observations of the executed Work as an experienced and qualified design professional, and on Engineer's review of the Application for Payment and the accompanying data and schedules, that to the best of Engineer's knowledge, information and belief:

- a. the Work has progressed to the point indicated;
  - b. the quality of the Work is generally in accordance with the Contract Documents (subject to an evaluation of the Work as a functioning whole prior to or upon Substantial Completion, the results of any subsequent tests called for in the Contract Documents, a final determination of quantities and classifications for Unit Price Work under Paragraph 13.03, and any other qualifications stated in the recommendation); and
  - c. the conditions precedent to Contractor's being entitled to such payment appear to have been fulfilled in so far as it is Engineer's responsibility to observe the Work.
3. By recommending any such payment Engineer will not thereby be deemed to have represented that:
- a. inspections made to check the quality or the quantity of the Work as it has been performed have been exhaustive, extended to every aspect of the Work in progress, or involved detailed inspections of the Work beyond the responsibilities specifically assigned to Engineer in the Contract; or
  - b. there may not be other matters or issues between the parties that might entitle Contractor to be paid additionally by Owner or entitle Owner to withhold payment to Contractor.
4. Neither Engineer's review of Contractor's Work for the purposes of recommending payments nor Engineer's recommendation of any payment, including final payment, will impose responsibility on Engineer:
- a. to supervise, direct, or control the Work, or
  - b. for the means, methods, techniques, sequences, or procedures of construction, or the safety precautions and programs incident thereto, or
  - c. for Contractor's failure to comply with Laws and Regulations applicable to Contractor's performance of the Work, or
  - d. to make any examination to ascertain how or for what purposes Contractor has used the money paid on account of the Contract Price, or
  - e. to determine that title to any of the Work, materials, or equipment has passed to Owner free and clear of any Liens.
5. Engineer may refuse to recommend the whole or any part of any payment if, in Engineer's opinion, it would be incorrect to make the representations to Owner stated in Paragraph 15.01.C.2.
6. Engineer will recommend reductions in payment (set-offs) necessary in Engineer's opinion to protect Owner from loss because:
- a. the Work is defective, requiring correction or replacement;
  - b. the Contract Price has been reduced by Change Orders;
  - c. Owner has been required to correct defective Work in accordance with Paragraph 14.07, or has accepted defective Work pursuant to Paragraph 14.04;
  - d. Owner has been required to remove or remediate a Hazardous Environmental Condition for which Contractor is responsible; or

- e. Engineer has actual knowledge of the occurrence of any of the events that would constitute a default by Contractor and therefore justify termination for cause under the Contract Documents.
- D. *Payment Becomes Due:*
- 1. Ten days after presentation of the Application for Payment to Owner with Engineer's recommendation, the amount recommended (subject to any Owner set-offs) will become due, and when due will be paid by Owner to Contractor.
- E. *Reductions in Payment by Owner:*
- 1. In addition to any reductions in payment (set-offs) recommended by Engineer, Owner is entitled to impose a set-off against payment based on any of the following:
    - a. claims have been made against Owner on account of Contractor's conduct in the performance or furnishing of the Work, or Owner has incurred costs, losses, or damages on account of Contractor's conduct in the performance or furnishing of the Work, including but not limited to claims, costs, losses, or damages from workplace injuries, adjacent property damage, non-compliance with Laws and Regulations, and patent infringement;
    - b. Contractor has failed to take reasonable and customary measures to avoid damage, delay, disruption, and interference with other work at or adjacent to the Site;
    - c. Contractor has failed to provide and maintain required bonds or insurance;
    - d. Owner has been required to remove or remediate a Hazardous Environmental Condition for which Contractor is responsible;
    - e. Owner has incurred extra charges or engineering costs related to submittal reviews, evaluations of proposed substitutes, tests and inspections, or return visits to manufacturing or assembly facilities;
    - f. the Work is defective, requiring correction or replacement;
    - g. Owner has been required to correct defective Work in accordance with Paragraph 14.07, or has accepted defective Work pursuant to Paragraph 14.04;
    - h. the Contract Price has been reduced by Change Orders;
    - i. an event that would constitute a default by Contractor and therefore justify a termination for cause has occurred;
    - j. liquidated damages have accrued as a result of Contractor's failure to achieve Milestones, Substantial Completion, or final completion of the Work;
    - k. Liens have been filed in connection with the Work, except where Contractor has delivered a specific bond satisfactory to Owner to secure the satisfaction and discharge of such Liens;
    - l. there are other items entitling Owner to a set off against the amount recommended.
  - 2. If Owner imposes any set-off against payment, whether based on its own knowledge or on the written recommendations of Engineer, Owner will give Contractor immediate written notice (with a copy to Engineer) stating the reasons for such action and the specific amount of the reduction, and promptly pay Contractor any amount

remaining after deduction of the amount so withheld. Owner shall promptly pay Contractor the amount so withheld, or any adjustment thereto agreed to by Owner and Contractor, if Contractor remedies the reasons for such action. The reduction imposed shall be binding on Contractor unless it duly submits a Change Proposal contesting the reduction.

3. Upon a subsequent determination that Owner's refusal of payment was not justified, the amount wrongfully withheld shall be treated as an amount due as determined by Paragraph 15.01.C.1 and subject to interest as provided in the Agreement.

#### 15.02 *Contractor's Warranty of Title*

- A. Contractor warrants and guarantees that title to all Work, materials, and equipment furnished under the Contract will pass to Owner free and clear of (1) all Liens and other title defects, and (2) all patent, licensing, copyright, or royalty obligations, no later than seven days after the time of payment by Owner.

#### 15.03 *Substantial Completion*

- A. When Contractor considers the entire Work ready for its intended use Contractor shall notify Owner and Engineer in writing that the entire Work is substantially complete and request that Engineer issue a certificate of Substantial Completion. Contractor shall at the same time submit to Owner and Engineer an initial draft of punch list items to be completed or corrected before final payment.
- B. Promptly after Contractor's notification, Owner, Contractor, and Engineer shall make an inspection of the Work to determine the status of completion. If Engineer does not consider the Work substantially complete, Engineer will notify Contractor in writing giving the reasons therefor.
- C. If Engineer considers the Work substantially complete, Engineer will deliver to Owner a preliminary certificate of Substantial Completion which shall fix the date of Substantial Completion. Engineer shall attach to the certificate a punch list of items to be completed or corrected before final payment. Owner shall have seven days after receipt of the preliminary certificate during which to make written objection to Engineer as to any provisions of the certificate or attached punch list. If, after considering the objections to the provisions of the preliminary certificate, Engineer concludes that the Work is not substantially complete, Engineer will, within 14 days after submission of the preliminary certificate to Owner, notify Contractor in writing that the Work is not substantially complete, stating the reasons therefor. If Owner does not object to the provisions of the certificate, or if despite consideration of Owner's objections Engineer concludes that the Work is substantially complete, then Engineer will, within said 14 days, execute and deliver to Owner and Contractor a final certificate of Substantial Completion (with a revised punch list of items to be completed or corrected) reflecting such changes from the preliminary certificate as Engineer believes justified after consideration of any objections from Owner.
- D. At the time of receipt of the preliminary certificate of Substantial Completion, Owner and Contractor will confer regarding Owner's use or occupancy of the Work following Substantial Completion, review the builder's risk insurance policy with respect to the end of the builder's risk coverage, and confirm the transition to coverage of the Work under a permanent property insurance policy held by Owner. Unless Owner and Contractor agree otherwise in writing, Owner shall bear responsibility for security, operation, protection of the Work, property insurance, maintenance, heat, and utilities upon Owner's use or occupancy of the Work.

- E. After Substantial Completion the Contractor shall promptly begin work on the punch list of items to be completed or corrected prior to final payment. In appropriate cases Contractor may submit monthly Applications for Payment for completed punch list items, following the progress payment procedures set forth above.
- F. Owner shall have the right to exclude Contractor from the Site after the date of Substantial Completion subject to allowing Contractor reasonable access to remove its property and complete or correct items on the punch list.

#### 15.04 *Partial Use or Occupancy*

- A. Prior to Substantial Completion of all the Work, Owner may use or occupy any substantially completed part of the Work which has specifically been identified in the Contract Documents, or which Owner, Engineer, and Contractor agree constitutes a separately functioning and usable part of the Work that can be used by Owner for its intended purpose without significant interference with Contractor's performance of the remainder of the Work, subject to the following conditions:
  - 1. At any time Owner may request in writing that Contractor permit Owner to use or occupy any such part of the Work that Owner believes to be substantially complete. If and when Contractor agrees that such part of the Work is substantially complete, Contractor, Owner, and Engineer will follow the procedures of Paragraph 15.03.A through E for that part of the Work.
  - 2. At any time Contractor may notify Owner and Engineer in writing that Contractor considers any such part of the Work substantially complete and request Engineer to issue a certificate of Substantial Completion for that part of the Work.
  - 3. Within a reasonable time after either such request, Owner, Contractor, and Engineer shall make an inspection of that part of the Work to determine its status of completion. If Engineer does not consider that part of the Work to be substantially complete, Engineer will notify Owner and Contractor in writing giving the reasons therefor. If Engineer considers that part of the Work to be substantially complete, the provisions of Paragraph 15.03 will apply with respect to certification of Substantial Completion of that part of the Work and the division of responsibility in respect thereof and access thereto.
  - 4. No use or occupancy or separate operation of part of the Work may occur prior to compliance with the requirements of Paragraph 6.05 regarding builder's risk or other property insurance.

#### 15.05 *Final Inspection*

- A. Upon written notice from Contractor that the entire Work or an agreed portion thereof is complete, Engineer will promptly make a final inspection with Owner and Contractor and will notify Contractor in writing of all particulars in which this inspection reveals that the Work, or agreed portion thereof, is incomplete or defective. Contractor shall immediately take such measures as are necessary to complete such Work or remedy such deficiencies.

#### 15.06 *Final Payment*

- A. *Application for Payment:*
  - 1. After Contractor has, in the opinion of Engineer, satisfactorily completed all corrections identified during the final inspection and has delivered, in accordance with the Contract Documents, all maintenance and operating instructions, schedules, guarantees, bonds, certificates or other evidence of insurance, certificates of

inspection, annotated record documents (as provided in Paragraph 7.11), and other documents, Contractor may make application for final payment.

2. The final Application for Payment shall be accompanied (except as previously delivered) by:
  - a. all documentation called for in the Contract Documents;
  - b. consent of the surety, if any, to final payment;
  - c. satisfactory evidence that all title issues have been resolved such that title to all Work, materials, and equipment has passed to Owner free and clear of any Liens or other title defects, or will so pass upon final payment.
  - d. a list of all disputes that Contractor believes are unsettled; and
  - e. complete and legally effective releases or waivers (satisfactory to Owner) of all Lien rights arising out of the Work, and of Liens filed in connection with the Work.
3. In lieu of the releases or waivers of Liens specified in Paragraph 15.06.A.2 and as approved by Owner, Contractor may furnish receipts or releases in full and an affidavit of Contractor that: (a) the releases and receipts include all labor, services, material, and equipment for which a Lien could be filed; and (b) all payrolls, material and equipment bills, and other indebtedness connected with the Work for which Owner might in any way be responsible, or which might in any way result in liens or other burdens on Owner's property, have been paid or otherwise satisfied. If any Subcontractor or Supplier fails to furnish such a release or receipt in full, Contractor may furnish a bond or other collateral satisfactory to Owner to indemnify Owner against any Lien, or Owner at its option may issue joint checks payable to Contractor and specified Subcontractors and Suppliers.

**B. *Engineer's Review of Application and Acceptance:***

1. If, on the basis of Engineer's observation of the Work during construction and final inspection, and Engineer's review of the final Application for Payment and accompanying documentation as required by the Contract Documents, Engineer is satisfied that the Work has been completed and Contractor's other obligations under the Contract have been fulfilled, Engineer will, within ten days after receipt of the final Application for Payment, indicate in writing Engineer's recommendation of final payment and present the Application for Payment to Owner for payment. Such recommendation shall account for any set-offs against payment that are necessary in Engineer's opinion to protect Owner from loss for the reasons stated above with respect to progress payments. At the same time Engineer will also give written notice to Owner and Contractor that the Work is acceptable, subject to the provisions of Paragraph 15.07. Otherwise, Engineer will return the Application for Payment to Contractor, indicating in writing the reasons for refusing to recommend final payment, in which case Contractor shall make the necessary corrections and resubmit the Application for Payment.

**C. *Completion of Work:*** The Work is complete (subject to surviving obligations) when it is ready for final payment as established by the Engineer's written recommendation of final payment.

**D. *Payment Becomes Due:*** Thirty days after the presentation to Owner of the final Application for Payment and accompanying documentation, the amount recommended by Engineer (less any further sum Owner is entitled to set off against Engineer's recommendation,

including but not limited to set-offs for liquidated damages and set-offs allowed under the provisions above with respect to progress payments) will become due and shall be paid by Owner to Contractor.

#### 15.07 *Waiver of Claims*

- A. The making of final payment will not constitute a waiver by Owner of claims or rights against Contractor. Owner expressly reserves claims and rights arising from unsettled Liens, from defective Work appearing after final inspection pursuant to Paragraph 15.05, from Contractor's failure to comply with the Contract Documents or the terms of any special guarantees specified therein, from outstanding Claims by Owner, or from Contractor's continuing obligations under the Contract Documents.
- B. The acceptance of final payment by Contractor will constitute a waiver by Contractor of all claims and rights against Owner other than those pending matters that have been duly submitted or appealed under the provisions of Article 17.

#### 15.08 *Correction Period*

- A. If within one year after the date of Substantial Completion (or such longer period of time as may be prescribed by the terms of any applicable special guarantee required by the Contract Documents, or by any specific provision of the Contract Documents), any Work is found to be defective, or if the repair of any damages to the Site, adjacent areas that Contractor has arranged to use through construction easements or otherwise, and other adjacent areas used by Contractor as permitted by Laws and Regulations, is found to be defective, then Contractor shall promptly, without cost to Owner and in accordance with Owner's written instructions:
  - 1. correct the defective repairs to the Site or such other adjacent areas;
  - 2. correct such defective Work;
  - 3. if the defective Work has been rejected by Owner, remove it from the Project and replace it with Work that is not defective, and
  - 4. satisfactorily correct or repair or remove and replace any damage to other Work, to the work of others, or to other land or areas resulting therefrom.
- B. If Contractor does not promptly comply with the terms of Owner's written instructions, or in an emergency where delay would cause serious risk of loss or damage, Owner may have the defective Work corrected or repaired or may have the rejected Work removed and replaced. Contractor shall pay all claims, costs, losses, and damages (including but not limited to all fees and charges of engineers, architects, attorneys, and other professionals and all court or arbitration or other dispute resolution costs) arising out of or relating to such correction or repair or such removal and replacement (including but not limited to all costs of repair or replacement of work of others).
- C. In special circumstances where a particular item of equipment is placed in continuous service before Substantial Completion of all the Work, the correction period for that item may start to run from an earlier date if so provided in the Specifications.
- D. Where defective Work (and damage to other Work resulting therefrom) has been corrected or removed and replaced under this paragraph, the correction period hereunder with respect to such Work will be extended for an additional period of one year after such correction or removal and replacement has been satisfactorily completed.

- E. Contractor's obligations under this paragraph are in addition to all other obligations and warranties. The provisions of this paragraph shall not be construed as a substitute for, or a waiver of, the provisions of any applicable statute of limitation or repose.

## ARTICLE 16 – SUSPENSION OF WORK AND TERMINATION

### 16.01 *Owner May Suspend Work*

- A. At any time and without cause, Owner may suspend the Work or any portion thereof for a period of not more than 90 consecutive days by written notice to Contractor and Engineer. Such notice will fix the date on which Work will be resumed. Contractor shall resume the Work on the date so fixed. Contractor shall be entitled to an adjustment in the Contract Price or an extension of the Contract Times, or both, directly attributable to any such suspension. Any Change Proposal seeking such adjustments shall be submitted no later than 30 days after the date fixed for resumption of Work.

### 16.02 *Owner May Terminate for Cause*

- A. The occurrence of any one or more of the following events will constitute a default by Contractor and justify termination for cause:
1. Contractor's persistent failure to perform the Work in accordance with the Contract Documents (including, but not limited to, failure to supply sufficient skilled workers or suitable materials or equipment or failure to adhere to the Progress Schedule);
  2. Failure of Contractor to perform or otherwise to comply with a material term of the Contract Documents;
  3. Contractor's disregard of Laws or Regulations of any public body having jurisdiction; or
  4. Contractor's repeated disregard of the authority of Owner or Engineer.
- B. If one or more of the events identified in Paragraph 16.02.A occurs, then after giving Contractor (and any surety) ten days written notice that Owner is considering a declaration that Contractor is in default and termination of the contract, Owner may proceed to:
1. declare Contractor to be in default, and give Contractor (and any surety) notice that the Contract is terminated; and
  2. enforce the rights available to Owner under any applicable performance bond.
- C. Subject to the terms and operation of any applicable performance bond, if Owner has terminated the Contract for cause, Owner may exclude Contractor from the Site, take possession of the Work, incorporate in the Work all materials and equipment stored at the Site or for which Owner has paid Contractor but which are stored elsewhere, and complete the Work as Owner may deem expedient.
- D. Owner may not proceed with termination of the Contract under Paragraph 16.02.B if Contractor within seven days of receipt of notice of intent to terminate begins to correct its failure to perform and proceeds diligently to cure such failure.
- E. If Owner proceeds as provided in Paragraph 16.02.B, Contractor shall not be entitled to receive any further payment until the Work is completed. If the unpaid balance of the Contract Price exceeds the cost to complete the Work, including all related claims, costs, losses, and damages (including but not limited to all fees and charges of engineers, architects, attorneys, and other professionals) sustained by Owner, such excess will be paid to Contractor. If the cost to complete the Work including such related claims, costs, losses,

and damages exceeds such unpaid balance, Contractor shall pay the difference to Owner. Such claims, costs, losses, and damages incurred by Owner will be reviewed by Engineer as to their reasonableness and, when so approved by Engineer, incorporated in a Change Order. When exercising any rights or remedies under this paragraph, Owner shall not be required to obtain the lowest price for the Work performed.

- F. Where Contractor's services have been so terminated by Owner, the termination will not affect any rights or remedies of Owner against Contractor then existing or which may thereafter accrue, or any rights or remedies of Owner against Contractor or any surety under any payment bond or performance bond. Any retention or payment of money due Contractor by Owner will not release Contractor from liability.
- G. If and to the extent that Contractor has provided a performance bond under the provisions of Paragraph 6.01.A, the provisions of that bond shall govern over any inconsistent provisions of Paragraphs 16.02.B and 16.02.D.

#### 16.03 *Owner May Terminate For Convenience*

- A. Upon seven days written notice to Contractor and Engineer, Owner may, without cause and without prejudice to any other right or remedy of Owner, terminate the Contract. In such case, Contractor shall be paid for (without duplication of any items):
  - 1. completed and acceptable Work executed in accordance with the Contract Documents prior to the effective date of termination, including fair and reasonable sums for overhead and profit on such Work;
  - 2. expenses sustained prior to the effective date of termination in performing services and furnishing labor, materials, or equipment as required by the Contract Documents in connection with uncompleted Work, plus fair and reasonable sums for overhead and profit on such expenses; and
  - 3. other reasonable expenses directly attributable to termination, including costs incurred to prepare a termination for convenience cost proposal.
- B. Contractor shall not be paid on account of loss of anticipated overhead, profits, or revenue, or other economic loss arising out of or resulting from such termination.

#### 16.04 *Contractor May Stop Work or Terminate*

- A. If, through no act or fault of Contractor, (1) the Work is suspended for more than 90 consecutive days by Owner or under an order of court or other public authority, or (2) Engineer fails to act on any Application for Payment within 30 days after it is submitted, or (3) Owner fails for 30 days to pay Contractor any sum finally determined to be due, then Contractor may, upon seven days written notice to Owner and Engineer, and provided Owner or Engineer do not remedy such suspension or failure within that time, terminate the contract and recover from Owner payment on the same terms as provided in Paragraph 16.03.
- B. In lieu of terminating the Contract and without prejudice to any other right or remedy, if Engineer has failed to act on an Application for Payment within 30 days after it is submitted, or Owner has failed for 30 days to pay Contractor any sum finally determined to be due, Contractor may, seven days after written notice to Owner and Engineer, stop the Work until payment is made of all such amounts due Contractor, including interest thereon. The provisions of this paragraph are not intended to preclude Contractor from submitting a Change Proposal for an adjustment in Contract Price or Contract Times or otherwise for

expenses or damage directly attributable to Contractor's stopping the Work as permitted by this paragraph.

## ARTICLE 17 – FINAL RESOLUTION OF DISPUTES

### 17.01 *Methods and Procedures*

- A. *Disputes Subject to Final Resolution:* The following disputed matters are subject to final resolution under the provisions of this Article:
1. A timely appeal of an approval in part and denial in part of a Claim, or of a denial in full; and
  2. Disputes between Owner and Contractor concerning the Work or obligations under the Contract Documents, and arising after final payment has been made.
- B. *Final Resolution of Disputes:* For any dispute subject to resolution under this Article, Owner or Contractor may:
1. elect in writing to invoke the dispute resolution process provided for in the Supplementary Conditions; or
  2. agree with the other party to submit the dispute to another dispute resolution process; or
  3. if no dispute resolution process is provided for in the Supplementary Conditions or mutually agreed to, give written notice to the other party of the intent to submit the dispute to a court of competent jurisdiction.

## ARTICLE 18 – MISCELLANEOUS

### 18.01 *Giving Notice*

- A. Whenever any provision of the Contract Documents requires the giving of written notice, it will be deemed to have been validly given if:
1. delivered in person, by a commercial courier service or otherwise, to the individual or to a member of the firm or to an officer of the corporation for which it is intended; or
  2. delivered at or sent by registered or certified mail, postage prepaid, to the last business address known to the sender of the notice.

### 18.02 *Computation of Times*

- A. When any period of time is referred to in the Contract by days, it will be computed to exclude the first and include the last day of such period. If the last day of any such period falls on a Saturday or Sunday or on a day made a legal holiday by the law of the applicable jurisdiction, such day will be omitted from the computation.

### 18.03 *Cumulative Remedies*

- A. The duties and obligations imposed by these General Conditions and the rights and remedies available hereunder to the parties hereto are in addition to, and are not to be construed in any way as a limitation of, any rights and remedies available to any or all of them which are otherwise imposed or available by Laws or Regulations, by special warranty or guarantee, or by other provisions of the Contract. The provisions of this paragraph will be as effective as if repeated specifically in the Contract Documents in connection with each particular duty, obligation, right, and remedy to which they apply.

18.04 *Limitation of Damages*

- A. With respect to any and all Change Proposals, Claims, disputes subject to final resolution, and other matters at issue, neither Owner nor Engineer, nor any of their officers, directors, members, partners, employees, agents, consultants, or subcontractors, shall be liable to Contractor for any claims, costs, losses, or damages sustained by Contractor on or in connection with any other project or anticipated project.

18.05 *No Waiver*

- A. A party's non-enforcement of any provision shall not constitute a waiver of that provision, nor shall it affect the enforceability of that provision or of the remainder of this Contract.

18.06 *Survival of Obligations*

- A. All representations, indemnifications, warranties, and guarantees made in, required by, or given in accordance with the Contract, as well as all continuing obligations indicated in the Contract, will survive final payment, completion, and acceptance of the Work or termination or completion of the Contract or termination of the services of Contractor.

18.07 *Controlling Law*

- A. This Contract is to be governed by the law of the state in which the Project is located.

18.08 *Headings*

- A. Article and paragraph headings are inserted for convenience only and do not constitute parts of these General Conditions.

SECTION 00800

SUPPLEMENTARY CONDITIONS

A. These Supplementary Conditions amend or supplement the Standard General Conditions of the Construction Contract EJCDC C-700 (2013 Edition) and other provisions of the Contract Documents as indicated below. All provisions which are not so amended or supplemented remain in full force and effect.

B. The terms used in these Supplementary Conditions have the meanings stated in the General Conditions. Additional terms used in these Supplementary Conditions have the meanings stated below which are applicable to both the singular and plural thereof.

C. Table of Contents

SC-2.03 Before Starting Construction.....	2
SC-3.03 Reporting and Resolving Discrepancies .....	2
SC-5.06.A Hazardous Environmental Conditions .....	2
SC-6.03 Contractor's Insurance.....	2
SC-6.04 Owner's Liability Insurance.....	3
SC-6.05 Property Insurance .....	3
SC-7.02 and 7.03 Labor, Working Hours, Services, Materials, and Equipment.....	3
SC-7.18 Indemnification .....	3
SC-10.03 Project Representative .....	3
SC-11.04 Change of Contract Price .....	4
SC-14.01 Access to Work.....	4
SC-14.02.A Tests and Inspections .....	4
SC-15.01.B Applications for Payments.....	4
SC-15.01.E Reduction in Payment by Owner .....	5
SC-15.06 Final Payment .....	5
SC-16.02 Owner May Terminate for Cause.....	5
SC-16.03 Owner May Terminate for Convenience .....	5

SC-2.03 Before Starting Construction

Add the following subparagraph to Paragraph 2.03A:

- 4. A proposed listing of subcontractors and major material suppliers. The list shall include any proposed substitutions in accordance with Paragraph 7.05.

SC-3.03 Reporting and Resolving Discrepancies

Add the following new paragraphs immediately after Paragraph 3.03.A:

- 4. Contractor shall report apparent discrepancies to Engineer. The Request for Information form shall:
  - a. be submitted by Contractor only;
  - b. be legible and complete;
  - c. not be used for the purposes of only confirming or verifying issues; and,
  - d. be prioritized by Contractor in the event that multiple Requests for Information are outstanding.

Requests for Information that are not in conformance with the requirements above shall be returned to Contractor without response.

5. Contractor shall not be relieved of its responsibility to coordinate the Work to prevent adverse impacts to Contractor's Project Schedule while submitting Requests for Information.

6. If Contractor believes the Scope of Work included in the Request for Information has a cost and/or time impact, Contractor should submit a claim in accordance with Article 11 of these General Conditions.

7. If Contractor proceeds with work when Contractor had actual knowledge or should have known that a conflict, error, ambiguity, or discrepancy existed as indicated above, correction of work constructed without such notification to Engineer shall be at Contractor's expense, (except in an emergency as authorized by Paragraph 7.15.A).

SC-5.06.A Hazardous Environmental Conditions

Delete Paragraphs 5.06.A in its entirety and insert the following:

A. No reports or drawings related to Hazardous Environmental Conditions are known to OWNER.

SC-6.03 Contractor's Insurance

Delete Paragraph 6.03 in its entirety and insert the following:

Insurance and indemnification shall be according to applicable sections of the Standard Specifications, and shall also be according to the "IRMA Contractual Insurance Guidelines", incorporated herein as Appendix 5. If a conflict is determined to exist between the requirements prescribed in the Standard Specifications and the requirements prescribed in the IRMA Contractual Insurance Guidelines, such conflict will be resolved as follows:

- a. If a particular type of insurance coverage is required by one standard but not by both, that type of insurance coverage will be required.
- b. If the minimum limits of insurance coverage required by one standard differ from those required by the other standard, the higher minimum limits of insurance coverage will prevail.

c. If any other conflicts are determined to exist between the requirements prescribed in the two standards, the stricter of the two requirements will prevail. Owner will make the final determination as to what constitutes a stricter requirement.

SC-6.04 Owner's Liability Insurance

Delete Paragraph 6.04 in its entirety and insert the same paragraph as SC-6.03.

SC-6.05 Property Insurance

Delete Paragraph 6.05 in its entirety and insert the same paragraph as SC-6.03.

SC-7.02 and 7.03 Labor, Working Hours, Services, Materials, and Equipment

Add the following new paragraph immediately after Paragraph 7.02.B:

- C. See the General Special Provisions for special requirements concerning working hours, etc.

SC-7.18 Indemnification

Delete Paragraph 7.18.C.1 and 7.18.C.2. Insert new Paragraphs 7.18.C.1, D and E:

- 1. The preparation of Drawings, Specifications, or Property Surveys.

D. For any matter for which Owner and Engineer are indemnified under Paragraph 7.18.A, Contractor shall pay for Owner's and Engineer's reasonable defense, including, but not limited to, all fees and charges of engineers, architects, attorneys, and other professionals and all court or arbitration or other dispute resolution costs or awards until Owner or Engineer are found negligent. If Owner or Engineer are found negligent, Owner or Engineer shall reimburse Contractor for the prorata extent of Owner's or Engineer's negligence for the cost of Owner's or Engineer's reasonable defense.

E. In Paragraphs 7.18.A. through D. as may be amended by the Supplementary Conditions, Engineer shall also include RJN Group Inc.

SC-10.03 Project Representative

Add the following new paragraphs immediately after Paragraph 10.03.A:

B. The duties and responsibilities of the resident project representative include the following:

- 1. Review schedules as required in Paragraph 2.05.A and amendment thereto.
- 2. Attend conferences and meetings with Contractor.
- 3. Serve as liaison between Engineer and Contractor and help Engineer serve as liaison between Owner and Contractor.
- 4. Conduct on-site observation of the work.
- 5. Observe tests.
- 6. Report to Engineer when clarifications and interpretations of the Contract Documents are needed. Consider, evaluate, and report to Engineer, Contractor's requests for modification.

7. Maintain orderly records, keep a daily log (when on a part-time basis, keep log for days visiting site), and furnish periodic reports to Engineer of the progress of the Work.
8. Before project completion, prepare final list of items to be completed or corrected and make recommendations to Engineer concerning acceptance of the Work.

The resident project representative shall not:

1. Authorize any deviation from the Contract Documents or substitutions of materials or equipment.
2. Exceed limitations of Engineer's authority as set forth in the Contract Documents.
3. Undertake any of the responsibilities of Contractor, Subcontractor, Suppliers or Contractor's superintendent.
4. Accept shop drawing or sample submittals from anyone other than Contractor.
5. Authorize Owner to occupy the Project in whole or in part.
6. Participate in specialized field or laboratory tests or inspections conducted off-site by others except as specifically authorized by Engineer.

#### SC-11.04 Change of Contract Price

Clarification of Paragraph 11.04.B.2: The overhead and profit allowance for lump sum work shall be in accordance with Paragraph 11.04.C.2 unless Owner and Contractor agree that these allowances are not appropriate for the Work involved.

#### SC-14.01 Access to Work

Add the following paragraph after Paragraph 14.01.A of the General Conditions:

- B. Representatives of the Illinois Environmental Agency (IEPA), or any of their duly authorized representatives will have full access to and the right to examine any pertinent books, documents, papers and records of Contractor involving transactions related to the project.

#### SC-14.02.A Tests and Inspections

Add the following to the end of Paragraph 14.02.A:

Samples required for testing shall be furnished by Contractor at no cost to Owner. In the event that completed Work does not conform to specification requirements during the initial test, the Work shall be corrected and retested for conformance. The entire cost of retesting completed Work shall be borne by Contractor. This shall include the extra cost for inspection to Owner which will be deducted from the final amount due Contractor.

#### SC-15.01.B Applications for Payments

Add the following paragraph after Paragraph 15.01.B.3:

4. Contractor shall submit with each pay request Contractor's partial waiver of lien for the full amount of the requested payment. Beginning with the second pay request, and with each succeeding pay request, Contractor shall submit partial waivers of lien for each Subcontractor and Supplier showing that the amount paid to date to each is at least equivalent to the total value of Subcontractor's or Supplier's work, less retainage, included on the previous pay request. Contractor shall submit with each pay request a signed Waiver of Lien Log clearly documenting the following:
  - a. The names of all Subcontractors/Suppliers on the project.

- b. Contract amounts for each Subcontractor/Supplier.
  - c. Amount paid to date to each Subcontractor/Supplier.
  - d. Lien waivers provided with current pay application for previous month's payments.
  - e. Amount to be paid to each Subcontractor/Supplier included in the pending pay request.
  - f. Remaining balance for each Subcontractor/Supplier.
- 5. Contractor shall submit one original and one copy of each lien waiver submitted.
  - 6. Contractor shall submit three copies of each pay request for approval.

SC-15.01.E Reduction in Payment by Owner

Add the following new paragraph after Paragraph 15.01.E.1.m:

- m. For failure of the Contractor of sub-contractors to make proper payments to his sub-contractors and suppliers. The Village shall have the right to act as agent for the Contractor in disbursing such funds as have been withheld pursuant to this paragraph to the party or parties who are entitled to payment therefrom. The Village will render to the Contractor a proper accounting of all such funds disbursed on behalf of the Contractor; and such payments shall be considered as payment made under the contract. The Village shall not be liable to the Contractor for any such payment made in good faith.

SC-15.06 Final Payment

Insert the following before the last sentence of Paragraph 15.06.A.3 of the General Conditions:

Contractor's request for final payment shall also include Contractor's final waiver of lien which shall be for the full amount of Contract, including any change orders thereto, and final waivers of lien from all subcontractors and suppliers for which final waivers of lien have not previously been submitted.

SC-16.02 Owner May Terminate for Cause

Add the following paragraph after Paragraph 16.02.A.4

- 5. In the event the Contractor voluntarily petitions for bankruptcy, or is adjudged bankrupt or makes a general assignment for the benefit of his creditors or if a receiver is appointed on account of his insolvency, or in the event that any of the provisions of this contract are violated by the Contractor or by any of his sub-contractors or the Village reasonably believes such violation is likely.

SC-16.03 Owner May Terminate for Convenience

Add the following paragraph after Paragraph 16.03.B:

B. Contractor shall require similar provisions contained in Paragraph 16.03 in each of its subcontracts to protect Contractor from claims by subcontractors arising from Owner's termination for convenience, or to minimize claims by such subcontractors. The remedy provided to Contractor under this Paragraph 16.03 shall be Contractor's sole remedy in the event of termination for convenience by Owner.

END OF SECTION

**OWNER COPY**

**CONTRACT**

*This page intentionally left blank.*

**OWNER COPY**

**CONTRACT**

**2019 SEWER REHABILITATION PROGRAM  
VILLAGE OF VILLA PARK**

**SPECIAL PROVISIONS**

**OWNER COPY**

**CONTRACT**

***This page intentionally left blank.***

**INDEX OF SPECIAL PROVISIONS**

<b>TITLE</b>	<b>PAGE NO.</b>
DEFINITIONS .....	7
LOCATION OF PROJECT .....	7
DESCRIPTION OF PROJECT .....	7
WORKING HOURS .....	8
HOLIDAYS .....	8
PUBLIC CONVENIENCE AND SAFETY (D-1) .....	8
MAINTENANCE GUARANTEE .....	9
MOBILIZATION .....	9
CONSTRUCTION SAFETY AND HEALTH STANDARDS .....	10
MAINTENANCE OF ROADWAYS .....	10
KEEPING ROADS OPEN TO TRAFFIC .....	10
RESPONSIBILITY FOR VANDALISM .....	10
SHOP DRAWINGS AND SUBMITTALS .....	11
CLEAN UP .....	12
BRACING AND SHEETING .....	13
PIPE BEDDING .....	13
SEWER FLOW CONTROL .....	13
FRAMES AND COVERS .....	15
DATE OF MANUFACTURE .....	15
SALVAGE AND DISPOSAL OF EXISTING CASTINGS .....	16
USE OF FIRE HYDRANTS .....	16
PROTECTION OF EXISTING DRAINAGE FACILITIES DURING CONSTRUCTION .....	17
POST-CONSTRUCTION TELEVISION INSPECTION FOR SEWER REPAIRS .....	18
MANHOLE REHABILITATION WARRANTY .....	18
RESTORATION - GENERAL .....	18
PCC DRIVEWAY PAVEMENT REMOVAL AND REPLACEMENT .....	19
PCC SIDEWALK, 5" .....	20
TOPSOIL FURNISH AND PLACE, 4" .....	20
SODDING .....	21
ITEM #1: PRE-CONSTRUCTION SURFACE TELEVISIONING .....	23

*This page intentionally left blank.*

**2019 SEWER REHABILITATION PROGRAM  
VILLAGE OF VILLA PARK**

ITEM #2: PRE-CONSTRUCTION CLEANING AND TELEVISIONING ..... 25

ITEM #3: LATERAL CLEANING AND TELEVISIONING ..... 33

ITEMS #4 THRU #9: CURED-IN-PLACE SEWER LINER, AND INTERNAL SERVICE  
LATERAL REINSTATEMENT ..... 34

ITEM #10: PROTRUDING TAP REMOVAL ..... 38

ITEM #11: DYE TESTING OF EXISTING SERVICE CONNECTIONS ..... 38

ITEMS #12: AIR TEST AND GROUT SERVICE CONNECTION ..... 39

ITEMS #13 & #14: T-LINER INSTALLATION ..... 42

ITEM #15 TO #23: POINT REPAIRS ..... 44

ITEM #24: NEW LATERAL SERVICE ..... 48

ITEM #25: REPLACE COVER ..... 49

ITEM #26: REPLACE FRAME AND COVER (UNPAVED) ..... 49

ITEMS #27 & #28: SEAL AND ADJUST MANHOLE FRAME (UNPAVED) OR UNCOVER  
AND RAISE BURIED MANHOLE (UNPAVED) ..... 50

ITEM #29: INTERNAL CHIMNEY SEAL ..... 51

ITEMS #30 TO #32: CURTAIN GROUT MANHOLE, GROUT WALL JOINTS, AND  
GROUT BOTTOM 18" ..... 52

ITEM #33: CEMENTITIOUS MANHOLE SEALING ..... 55

ITEM #34: REPAIR BENCH AND TROUGH ..... 58

ITEM #35: REPLACE BENCH AND TROUGH ..... 59

ITEM #36: VACUUM TESTING ..... 59

ITEM #37: WATER USAGE DEDUCTION ..... 61

ITEM #38: WATER USAGE CREDIT ..... 61

ITEM #39: PROJECT MANAGEMENT ..... 62

ITEM #40: TRAFFIC CONTROL AND PROTECTION ..... 62

*This page intentionally left blank.*

**APPENDIX 1:**

- SEWER LINING, GROUTING AND POINT REPAIR LOCATION MAP (EXHIBIT 0)

**APPENDIX 2:**

- POINT REPAIR SCHEDULE
- POINT REPAIR, T-LINER AND LATERAL SERVICE TELEVISIONING REPORTS
- POINT REPAIR PHOTO REPORT
- PLAN AND PROFILE SHEETS (NO. 1 TO 5), AND DETAIL SHEET (NO. 6)

**APPENDIX 3:**

- SEWER LINING AND GROUTING SCHEDULES
- SEWER LINING AND GROUTING LOCATION MAPS (EXHIBIT 1 TO 5)

**APPENDIX 4:**

- MANHOLE REHABILITATION SCHEDULE
- MANHOLE REHABILITATION LOCATION MAP 1 (EXHIBIT 6)
- MANHOLE REHABILITATION LOCATION MAP 2 (EXHIBIT 7)

**APPENDIX 5:**

- ORDINANCE AMENDING THE REQUIREMENTS OF BIDDERS FOR CONSTRUCTION PROJECTS
- IRMA CONTRACTUAL INSURANCE GUIDELINES

**APPENDIX 6:**

- IDOT STANDARD DETAILS

*This page intentionally left blank.*

**PROJECT SPECIAL PROVISIONS  
FOR  
2019 SEWER REHABILITATION PROGRAM**

Construction provisions shall follow the "Standard Specifications for Road and Bridge Construction", adopted April 1, 2016 (referred to hereinafter as the Standard Specifications); the "Supplemental Specifications and Recurring Special Provisions", adopted January 1, 2019; the latest edition of the "Illinois Manual on Uniform Traffic Control Devices For Streets and Highways" (IMUTCD); and the "Standard Specifications for Water and Sewer Construction in Illinois", 7th Edition, 2014 (referred to hereinafter as the Water and Sewer Specifications), except as modified herein. In case of conflict with any part, or parts, of said Specifications, the said Special Provisions shall take precedence and shall govern. Where no conflict exists, the said Specifications shall apply to this Contract as if repeated in their entirety herein.

**DEFINITIONS**

**Contractor.** The individual, firm, partnership, joint venture, or corporation contracting with the Village of Villa Park for performance of the prescribed work.

**Department, Owner or Village.** The Village of Villa Park, DuPage County, Illinois.

**Engineer.** The Resident Engineer who is the authorized representative of the Village of Villa Park in immediate charge of the engineering details of a construction project.

**LOCATION OF PROJECT**

The proposed work is officially known as the "2019 SEWER REHABILITATION PROGRAM". The project involves the rehabilitation of the sanitary sewer system in multiple locations throughout the Village of Villa Park, County of DuPage, State of Illinois as shown on the Plans. Some of the work will be located in backyards of private properties.

**DESCRIPTION OF PROJECT**

The work will consist of the rehabilitation of 30 manholes, 22,000 linear feet of sewer lining with diameter ranging between 8" and 21", grouting of 100 laterals, installation of 2 T-liners and 1 new service lateral, 4 point repairs, restoration and other related and incidental work.

**GENERAL SPECIAL PROVISIONS**

**WORKING HOURS**

Working hours will be between 7:00 A.M. and 5:00 P.M., Monday through Friday, excluding holidays as designated by the Contract.

The segment of sewer lining from manhole 1-024 to manhole 1-023 on North Villa will require the installation to be undertaken overnight from 10:00 P.M. to 6 A.M. Contractor is to plan and bid accordingly.

Excluding the segment mentioned above on North Villa, Contractor is not permitted to perform Work outside these working hours without Owner's written consent, which may be given after prior written request to Engineer, except as otherwise required for the safety of persons or the Work or property at the Site or adjacent thereto, and except as otherwise stated in the Contract Documents.

If Contractor permits the performance of Work outside these working hours (with the exception of the segment on North Villa), Contractor will compensate Owner for the costs of inspection and other services provided by Engineer. Owner will determine the rates at which such inspection and other services are to be compensated. Owner will determine the interval or intervals at which billing will take place, and may, at Owner's discretion, submit invoices for payment to Contractor, or deduct the costs from any monies due or to become due to the Contractor from Owner.

**HOLIDAYS**

Revise the list of legal holidays in Article 107.09 of the Standard Specifications to read:

- |                  |                            |
|------------------|----------------------------|
| New Year's Day   | Thanksgiving Day           |
| Easter           | <u>Thanksgiving Friday</u> |
| Memorial Day     | <u>Christmas Eve</u>       |
| Independence Day | Christmas Day              |
| Labor Day        | <u>New Year's Eve</u>      |

**PUBLIC CONVENIENCE AND SAFETY (D-1)**

Effective: May 1, 2012  
Revised: July 15, 2012

Add the following to the end of the fourth paragraph of Article 107.09:

**2019 SEWER REHABILITATION PROGRAM  
VILLAGE OF VILLA PARK**

“If the holiday is on a Saturday or Sunday, and is legally observed on a Friday or Monday, the length of Holiday Period for Monday or Friday shall apply.”

Add the following sentence after the Holiday Period table in the fourth paragraph of Article 107.09:

“The Length of Holiday Period for Thanksgiving shall be from 5:00 AM the Wednesday prior to 11:59 PM the Sunday After”

Delete the fifth paragraph of Article 107.09 of the Standard Specifications:

“On weekends, excluding holidays, on roadways with Average Daily Traffic of 25,000 or greater, all lanes shall be open to traffic from 3:00 P.M. Friday to midnight Sunday except where structure construction or major rehabilitation makes it impractical.”

**MAINTENANCE GUARANTEE**

The Contractor shall execute and deliver to the Village, before final payment will be issued, a written warranty, in a form satisfactory to the Village, which guarantees that the work is in accordance with the Contract Documents and will not be defective. This warranty shall guarantee this work for a period of one year from the date of acceptance of the work and final payment by the Village, with the exception of manhole rehabilitation which shall be guaranteed for three (3) years.

The Contractor shall furnish a warranty bond in an amount equal to ten percent (10%) of the contract amount, or \$100,000, whichever is greater, by a surety satisfactory to the Village to guarantee Contractor’s warranty to repair defective work.

If within the guarantee period, any work is found to be defective, as determined by the Village, the Contractor shall promptly and without cost to the Village, correct or repair such defective work, or remove and replace the defective work in accordance with the Special Provisions for the items in question.

**MOBILIZATION**

Mobilization shall be according to Section 671 of the Standard Specifications except as modified herein.

Revise Article 671.02, Basis of Payment, to read:

“**671.02 Basis of Payment.** Mobilization will not be paid for separately but shall be included in the unit bid prices of the items for which this work applies.”

**CONSTRUCTION SAFETY AND HEALTH STANDARDS**

It is a condition of this contract and shall be made a condition of each subcontract entered into pursuant to this contract that the Contractor and any Subcontractor shall not require any laborer or mechanic employed in performance of that contract to work in surroundings or under working conditions which are unsanitary, hazardous or dangerous to their health or safety, as determined under Federal Construction Safety and Health Standards.

**MAINTENANCE OF ROADWAYS**

Effective: September 30, 1985

Revised: November 1, 1996

Beginning on the date that work begins on this project, the Contractor shall assume responsibility for normal maintenance of all existing roadways within the limits of the work. This normal maintenance shall include all repair work deemed necessary by the Engineer, but shall not include snow removal operations. Traffic control and protection for maintenance of roadways will be provided by the Contractor as required by the Engineer.

If items of work have not been provided in the contract, or otherwise specified for payment, such items, including the accompanying traffic control and protection required by the Engineer, will be paid for in accordance with Article 109.04 of the "Standard Specifications".

**KEEPING ROADS OPEN TO TRAFFIC**

All roads shall remain open to traffic unless otherwise shown on the contract plans. When necessary to close one lane because of construction, the Contractor shall maintain one-way traffic during construction hours with the use of signs and flaggers as shown on the Traffic Control Standards. Two lanes of traffic will be maintained during nights and weekends when no construction activities are being carried on.

**RESPONSIBILITY FOR VANDALISM**

The contractor shall be responsible for the defacement of any concrete pours before they have set up. Concrete pavement, sidewalk, driveway, or curbing that has been defaced, in the opinion of the Engineer, shall be removed and replaced by the contractor at Contractor's own expense.

**SHOP DRAWINGS AND SUBMITTALS**

Prior to fabrication of materials, the Contractor shall submit shop drawings of the materials to the Engineer for review. Shop drawings shall consist of complete descriptive literature on the materials including all pertinent dimensions, material specifications, and data. Prior to submitting shop drawings to the Engineer, the Contractor shall first review the shop drawings and make corrections or revisions which are appropriate. A minimum of three (3) copies of shop drawings must be submitted. Two (2) of the copies submitted shall be retained for use by the Engineer and Owner, and the remaining copies shall be returned to the Contractor. The Contractor shall be required to maintain a complete set of shop drawings on the job site at all times while work is in progress and shall make them available to the Engineer upon request.

Submit the following shop drawings, submittals, certifications and samples required in the specifications:

1. Material Data Sheet Submittals: (3) copies or (1) electronic copy. All materials data sheets are to be submitted to the Engineer and approved before rehabilitation can proceed.
  - a. Liner Design Work Sheets.
  - b. Liner End Seals Data Sheet.
    - a. PVC sewer pipes: Shall conform to ASTM D2241 and shall be SDR 26
    - c. Non-shear couplings with stainless steel bands: Fernco RC series or Flex-Seal adjustable repair couplings or approved equal.
  - d. Manhole Rehabilitation Material Data Sheets.
    - i. Manhole Castings Data Sheets: Shall be conform to materials detailed in paragraph *FRAMES AND LIDS*.
    - ii. External Chimney Seal: Shall conform to ASTM C923 and shall be Infi-Shield Uni-bands.
    - iii. Internal Chimney Seal: SSI Flex-Seal or approved equal.
    - iv. Manhole Grouting Data Sheets:
      - Grout. Grouting installation shall conform to ASTM F2414-04. Grout shall be Avanti AV-100 or approved equal.
      - Severe Active Infiltration. Approved Materials to stop severe active infiltration are the following: Hydrostop-Flex 40/500; Avanti AV-202; Deneef Deneproxx 40; or approved equal.
    - v. Manhole Internal Coatings Material Data Sheets:
      - Patching Material. The following are approved for patching material: Strong Seal QSR ; Quadex Hyperform; or approved equal.

**2019 SEWER REHABILITATION PROGRAM  
VILLAGE OF VILLA PARK**

- Cementitious Coat. The following are approved for cementitious coat: Strong Seal MS-2C; or approved equal.
  - Visible Infiltration. Approved materials to stop visible infiltration are the following: Strong-Plug; Quadex Quad-Plug; or approved equal.
  - Copolymer latex. Approved material to use with AV-100 is the following: AV-257 ICOSSET or approved equal.
  - vi. Adjustment Rings: Shall be precast concrete. Adjustment rings of uniform thickness shall be at least two inches thick. The replacement precast grade adjustment shall provide a structural capacity equal to or greater than the existing specified manhole frame, and shall not affect the opening size or surface appearance.
  - vii. Bitumastic Gasket Material: Shall meet or exceed Federal Specification SS-S- 210A. Material shall be EZ-STIK or approved equal.
  - e. Service Lateral Grouting Data Sheets.
  - f. T-Liner detailed sheets
2. Pre & Post construction internal television inspection: two (2) digital copies
  3. Two (2) External USB powered hard drives containing:
    - a. Digital video files (MPEG format)
    - b. PDFs of digital reports
    - c. Digital database with observation data
    - d. Master spreadsheet with hyperlinks to video and PDF reports
  4. One set of "red-line" field changes on construction plans.
  5. Typical set-up for flow bypassing.
  6. Other required submittals: (3) copies or (1) electronic copy if required for review or record

This is a non-exhaustive list. The Contractor shall provide all shop drawings that are required in the specifications.

**CLEAN UP**

The cost of cleanup operations shall be spread evenly through the bid items on the proposal. Clean up shall consist of removing all debris from the job site, and removal of all excess dirt, pipe pieces, lumber scraps, paper cups, etc., left by the Contractor's forces. Clean up shall be performed as the work progresses, and a final clean up shall be done after all operations are completed.

**BRACING AND SHEETING**

**Description.** The Contractor, if necessary, shall furnish, place and maintain all bracing and sheeting to safeguard adjacent utilities, as well as the work done under this contract.

**Basis of Payment.** The cost of such required bracing and sheeting will not be paid for separately but shall be considered as included in the unit bid prices of the contract, and additional compensation will not be allowed.

**PIPE BEDDING**

**Description.** The Contractor shall furnish, place, compact and transport coarse aggregate as detailed hereinafter for pipe bedding to a minimum depth of 4" below the bell of the pipe and 12" above the bell of the pipe.

**Construction Methods.** The bedding for pipe installation shall be as shown on the Drawings. The aggregate gradations for bedding depending on the pipe material shall be as follows:

1. PVC Pipe: CA 7 or 11,  $\frac{3}{4}$ -1" washed gravel,
2. Concrete Pipe: CA 7, 1" washed gravel,
3. Ductile Iron Pipe: CA 7, 1" washed gravel,
4. Cables, Copper Water Services: CA 7, 1" washed gravel,
5. Trench bottom stabilization: CA 7, 1" washed gravel.

**Basis of Payment.** The cost of pipe bedding will not be paid for separately but shall be considered as included in the unit bid prices of the contract, and additional compensation will not be allowed.

**SEWER FLOW CONTROL**

This work shall include control of sanitary sewer flow during closed circuit television (CCTV) inspection, sewer cleaning operations, manhole rehabilitation, manhole installation and all other sewer maintenance, inspection or construction activities. The Contractor shall be fully responsible for maintaining sewer service during these operations and shall not be allowed to backup or flood any sewer system user, building or property. The Contractor shall be solely liable for property damages that result from the work being performed.

During sewer cleaning operations, only 25% of the internal pipe diameter flow or "limited sewage flow" is acceptable. Flows shall be reduced by plugging, blocking, manually operating pump stations or bypass pumping. During sewer televising operations, NASSCO Standards must be followed and only 5% of the internal pipe diameter flow is

acceptable. During manhole installation, manhole rehabilitation and point repairs, no flows will be allowed.

Since complete stoppage or bypassing of flow may be required during installation of new sewers, point repairs and manhole rehabilitation work, the Contractor may be required to submit drawings and complete design data showing methods and equipment to be utilized in bypass and dewatering operations. The bypass plan shall include the following information:

1. Location of temporary sewer plugs and bypass discharge lines indicated on plans
2. Capacities of pumps, prime movers, and standby equipment
3. Type of standby power source
4. Traffic control plan

The Contractor shall indicate where and when flow bypassing is anticipated and provide a typical set-up as a submittal. When pumping and bypassing is required, the Contractor shall furnish all temporary pumps, conduits, and other equipment to divert the flow of sewage around the sewer section in which work is to be performed. The bypass system shall have sufficient capacity to handle existing flow plus additional flow that may occur during peak flow periods or from precipitation. The Contractor shall construct bypass system of material to prevent leakage during pumping operation.

The Contractor shall equip all engines with mufflers and/or enclose to keep noise level less than 50 decibels, or 10 decibels above ambient noise levels when measured at building closest to noise source.

The Contractor shall maintain sufficient labor, equipment and materials on site to ensure continuous and successful operation of bypass and dewatering systems including the following:

1. Keep standby pumps fueled and operational at all times.
2. Maintain on site sufficient number of valves, tees, elbows, connections, tools, sewer plugs, piping, and other parts or system hardware to ensure immediate repair or modification of any part of system as necessary.
3. Provide piping, joints and accessories designed to withstand at least twice the maximum system pressure or 50 psi (345 kPa), whichever is greater.

In areas where flows are bypassed, all discharge flow shall be returned to the sanitary sewer. No bypassing to ground surface, receiving waters, storm drains, or bypassing which results in groundwater contamination or potential health hazards shall be permitted.

In the event sewage is released into a storm drainage system or street, the Contractor shall immediately stop the release, notify IEPA, and take all necessary actions to clean up and disinfect spillage to satisfaction of the Engineer.

**2019 SEWER REHABILITATION PROGRAM  
VILLAGE OF VILLA PARK**

During plugging or bypass pumping operations the Contractor shall utilize sewer plugs specifically designed so that all or any portion of sewage can be released. During sewer flow control operations, reduce flow to comply with requirements as describe above. After cleaning, inspection, installation or rehabilitation work has been completed, restore the flow to normal. All plugging, bypass pumping and sewer flow control operations shall be considered incidental to the Contract and shall not be compensated for separately.

**Basis of Payment.** The cost of sewer flow control will not be paid for separately but shall be considered as included in the unit bid prices of the contract, and additional compensation will not be allowed.

**FRAMES AND COVERS**

Frames and lids and all other castings furnished under this contract shall be in accordance with Section 602 and Section 604 of the Standard Specifications, except as modified herein.

Castings shall conform to ASTM A48 Class 30. Castings shall be free of cracks, holes, swells, cold shuts, and patches. Castings shall not be coated or painted.

Frames and covers and other castings shall be furnished in accordance with the following:

1. Sanitary manholes shall be furnished with Type 1 frames and closed covers. Type 1 frames and closed covers shall be Neenah R-1713 self-sealing or approved equal.

All other castings not specified above shall be as shown on the plans or as directed by the Engineer. If any of the castings specified are not compatible in the field due to frame height or other constraints, the Contractor shall propose an alternate casting to the Engineer for approval and shall furnish the alternate casting if approved.

All closed cover castings furnished under this contract shall be self-sealing, gasketed, watertight, and shall have machined bearing surfaces and concealed pick holes. The top surface of all closed covers shall be embossed with the words "VILLAGE OF VILLA PARK". The top surface of closed lids shall also be embossed with the word "SANITARY", as appropriate.

This work will not be paid for separately but shall be included in the cost of all pay items that include the furnishing of frames, grates, covers, or other castings.

**DATE OF MANUFACTURE**

All manufactured materials furnished under this contract, including, but not limited to, pipe, drainage and utility structures, castings, fire hydrants, valves, stops, and fittings,

**2019 SEWER REHABILITATION PROGRAM  
VILLAGE OF VILLA PARK**

shall have been manufactured no earlier than January 1 of the calendar year in which they are to be installed.

**SALVAGE AND DISPOSAL OF EXISTING CASTINGS**

Existing castings which are removed and are not to be reused will be inspected by the Engineer. Castings which are determined by the Engineer to be in satisfactory condition shall remain the property of the Village and shall be delivered by the Contractor to the Village of Villa Park Public Works Department yard located at 35 South Ardmore Avenue in Villa Park. Castings which are determined by the Engineer to be in unsatisfactory condition shall become the property of the Contractor and shall be removed from the site immediately and properly disposed of by the Contractor. The delivery or disposal of castings will not be paid for separately but shall be included in the cost of all items that include removal of an existing structure or casting.

**USE OF FIRE HYDRANTS**

Revise Article 107.18, Use of Fire Hydrants, of the Standard Specifications to read:

**“107.18 Use of Fire Hydrants.** If Contractor requires water for the completion of construction operations, and desires to obtain water from the Village, the Contractor shall make written application to the Village. If such application is approved by the Village, the Contractor shall obtain water from the fire hydrant located at 100 West Home Avenue, adjacent to the Village of Villa Park Fleet Maintenance Garage. Contractor’s use of said hydrant and methods of obtaining water shall be in compliance with all applicable ordinances, rules, and regulations concerning such use. Contractor shall furnish all labor and equipment necessary to make a connection to said hydrant, and to obtain and transport water.

Prior to obtaining water, Contractor shall make written application to the Village for temporary use of a hydrant meter. If the application for temporary use of a hydrant meter is approved, the Contractor shall provide a deposit of three thousand dollars (\$3,000.00) to the Village for the temporary use of said hydrant meter, which deposit will be held by the Village until such time that the meter is returned to the Village by the Contractor in satisfactory condition. Contractor shall use said hydrant meter when obtaining water, and shall comply with all conditions for the use of said meter. Contractor shall return the hydrant meter to the Village within 24 hours of project completion and within 24 hours of any request by the Village that the hydrant meter be returned.

If Contractor makes application for temporary use of a hydrant meter and the application is not approved, Contractor shall make record of the quantity of water obtained, along with the date and time obtained, and shall report such information after each use to the Village of Villa Park Public Works Department, 11 West Home Avenue. If such use takes place outside of the normal working hours of the Public Works Department, Contractor

**2019 SEWER REHABILITATION PROGRAM  
VILLAGE OF VILLA PARK**

shall report such information immediately upon the commencement of normal working hours.

Contractor shall not use, operate or obtain water from any hydrants other than the hydrant prescribed. Contractor shall not obtain water from the Village for construction operations or activities not under contract with the Village.

If a water main break occurs and the Village determines that the water main break is a result of Contractor's use of a hydrant, the Village may require the Contractor to repair the water main break in accordance with all applicable construction standards and requirements and at no cost to the contract, or may repair the water main break by other means and invoice the Contractor for reimbursement of the Village's costs.

Water usage will be measured according to the Special Provisions WATER USAGE DEDUCTION and WATER USAGE CREDIT."

**PROTECTION OF EXISTING DRAINAGE FACILITIES DURING CONSTRUCTION**

Unless otherwise noted in the contract plans, the existing drainage facilities shall remain in use during the period of construction.

Locations of existing drainage structures and sewers, if shown on the contract plans, are approximate. Prior to commencement of work, the Contractor, at his/her own expense, shall determine the exact location of existing structures which are within the proposed construction site.

All drainage structures are to be kept free from any debris resulting from construction operations. All work and materials necessary to prevent accumulation of debris in the drainage structure resulting from construction operations shall be removed at the Contractor's own expense, and no extra compensation will be allowed.

Unless reconstruction or adjustment of an existing manhole, catch basin, or inlet is called for in the contract plans or ordered by the Engineer, the proposed work shall meet the existing elevations of these structures. Should reconstruction or adjustment of a drainage structure be required by the Engineer in the field, the necessary work and payment shall be done in accordance with Section 602 and Article 104.02 respectively, of the Standard Specifications.

Existing frames and grates are to remain unless otherwise noted in the contract plans or as directed by the Engineer. Frames and grates that are missing or damaged prior to construction shall be replaced. The type of replacements frame or grate shall be determined by the Engineer, and replacement and payment for same shall be in accordance with Section 604 and Article 104.02 respectively, of the Standard Specifications unless otherwise noted in the plans or special provisions.

**POST-CONSTRUCTION TELEVISION INSPECTION FOR SEWER REPAIRS**

Post-construction internal television inspection shall be conducted on all sewers receiving sewer repairs. This inspection shall be per NASSCO standards by PACP certified operators.

Digital video inspections of the post-rehabilitation television inspection for each sewer section shall be provided to the Engineer and the Village as described below:

**Deliverables.** After the work is completed, the Contractor shall provide to the Village two (2) hard drives containing each video file and associated PDF report, which shall document, to the satisfaction of the Engineer, the condition of the sewer repairs immediately after rehabilitation and that it has been installed correctly and that all of the active connections have been restored. This review will be required prior to authorization for lining the segment.

**Basis of Payment.** POST-CONSTRUCTION TELEVISION INSPECTION and all deliverables shall be considered incidental to the Contract and shall not be compensated for separately.

**MANHOLE REHABILITATION WARRANTY**

Rehabilitation work performed on all manholes shall be warranted from defects and failure for a period of 3 years from the date of final acceptance. If the materials and installation furnished by the Contractor fail during this period, the Contractor shall repair the manhole at no expense to the Village.

**RESTORATION - GENERAL**

All damage to lawns shall be restored with topsoil and sod. All lawn restoration shall be considered incidental to the cost of the cured-in-place pipelining, service laterals grouting, manhole rehabilitation and point repairs. To minimize damage to lawns, Contractor shall utilize Duramats or other means to buffer equipment traveling across private property.

All work required to move or protect overhead wires and utility poles shall be considered incidental to the contract.

Any claims for additional work must be presented to the Engineer immediately. Failure of the contractor to notify the Engineer will be reason to deny any claims for extra work.

All work covered under this contract is subject to inspection by the Village of Villa Park and the Engineer.

2019 SEWER REHABILITATION PROGRAM  
VILLAGE OF VILLA PARK

The Contractor is responsible for coordinating access to manholes located in backyards with the homeowners and this work shall be incidental to the contract.

**PCC DRIVEWAY PAVEMENT REMOVAL AND REPLACEMENT**

**Description.** This work includes the removal of existing PCC driveway pavement in accordance with Section 440 of the Standard Specifications, and also includes furnishing all materials, equipment, and labor necessary to install PCC driveway pavement in accordance with Section 423 of the Standard Specifications and the following:

The removal and placement of PCC driveway pavement shall be performed at locations shown on the Plans and as designated by the Engineer.

The use of drop hammers will not be allowed for breaking these pavements. These driveways shall be excavated to the subgrade of the proposed driveway, including the necessary thickness of compacted, CA-6 stone. This work shall be included in the cost of this item.

The limits of removal shall typically be from the back of curb to the face of sidewalk, but shall be designated in the field by Engineer.

The Contractor shall saw-cut the driveway pavement full-depth at the limits of removal, which costs shall be included in this item. All driveway aprons scheduled for replacement shall be removed with extreme care in order to avoid damage to existing garages, garage foundations, or adjacent sidewalks scheduled to remain. Any damage caused by the removal of the driveway pavement shall be repaired or otherwise resolved by the Contractor to the satisfaction of the Village and the property owner. No additional compensation will be allowed. Any additional excavation required to reach the proposed subgrade shall be considered included in the cost of this item.

Additionally, if any additional stone bedding is needed to offset an unforeseen thickness of driveway removal, the additional stone would be paid for under this item as well.

The driveway shall be placed upon a cushion of compacted crushed stone, Gradation CA-6, having a minimum thickness of four inches (4"). The installation of this bedding shall be included in the cost of this item. The Engineer shall determine the limits and joint patterns of proposed driveway areas.

Full-depth (6"), bituminous expansion joint fillers (3/4" thick) shall be placed along all proposed curb and gutter and along all existing sidewalk.

The Contractor shall replace the entire driveway apron.

**Basis of Payment.** This work will be considered incidental to the *POINT REPAIR #4* item for which part of the work is located in a PCC driveway.

**PCC SIDEWALK, 5"**

**Description.** This work shall be according to Article 424 of the Standard Specifications and the following:

The five inch (5") thick Portland Concrete Cement (P.C.C.) sidewalk shall be constructed to the limits and grade required to blend with adjoining surfaces. The sidewalk shall be placed upon a base of compacted crushed stone, Gradation CA-6, having a minimum thickness of four inches (4"). The installation of this bedding shall be included in the cost of this item. Full depth expansion joints shall be placed between the sidewalk and the back of any adjacent curb, sidewalk, or buildings, and as directed by the Engineer.

Steel forms will not be allowed.

**Basis of Payment.** This work will be considered incidental to the *ITEM #24 NEW LATERAL SERVICE* for which part of the work is located in a PCC sidewalk.

**TOPSOIL FURNISH AND PLACE, 4"**

**Description.** This work shall be according to Article 211 of the Standard Specifications and the following:

The Contractor shall take precautions so as not to unnecessarily damage lawns. In areas that are designated to be sodded, the existing sod shall be cut and removed; the area shall then be shaped, graded and rototilled. The area to be sodded shall then have a layer of good quality, pulverized topsoil which has been approved by the Engineer prior to placement, spread and fine raked in such a manner as to result in a top dressing of the parkway having an average thickness of four inches (4") of topsoil.

Any excavation and grading of the parkway which is required to give a uniform slope from the limit of sod restoration to the top of the curb shall be included in this item. The Contractor shall be responsible for removing any weeds prior to the placement of the sod. The method of weed removal must be approved by the Engineer.

The topsoil and subgrade shall be thoroughly compacted along newly installed concrete by a compaction method approved by the Engineer. If proper compaction is not achieved, the Engineer may direct the Contractor to remove any soil backfill that the Contractor has placed and replace it with a granular stone backfill. This will be included in the cost of this item.

**Basis of Payment.** This work shall be considered incidental to the Contract and shall not be compensated for separately.

**SODDING**

**Description.** This work shall be according to Article 252 of the Standard Specifications and the following:

This item shall consist of the placement of sod on all landscaped areas disturbed by construction as shown on the Plans or as directed by the Engineer. Any excessive or unnecessary damage to the parkway or backyards will be restored by the Contractor at his own expense.

After the parkway and backyard areas designated for sodding have received the layer of topsoil, the areas shall be carefully graded, fine-raked, rolled, and then covered with a good quality of grass sod. Kentucky Blue or Merion Blue sod shall be used. The minimum area of any piece of sod to be placed shall be one (1) square foot with no side being less than six inches (6") in length.

The Contractor shall be responsible for watering the sod in accordance with Section 252 of the Standard Specifications. Upon completion of the 30 day period, the Contractor shall notify the Engineer in writing and request an inspection. The Engineer shall inspect the sod and shall supply the Contractor with a written punch list of any areas that are found unacceptable.

**Basis of Payment.** This work shall be considered incidental to the Contract and shall not be compensated for separately.

**OWNER COPY**

**CONTRACT**

**2019 SEWER REHABILITATION PROGRAM  
VILLAGE OF VILLA PARK**

**SPECIAL PROVISIONS FOR CONTRACT ITEMS**

This shall be a unit price contract and shall include all work mentioned in the Project's Plans and Specifications and any other work, not specifically mentioned, that is necessary for constructing the improvement in a skilled and professional manner. Any conflicts or omissions in the Plans or Specifications shall be brought to the attention of the Engineer. The Engineer's decision in resolving such matters shall be final. The Contractor shall in no manner take advantage of conflicts or omissions should they occur and it shall be the Contractor's responsibility to bring such components of the Contract to the attention of the Engineer so that they can be properly resolved.

The quantities bid upon in the Proposal are estimated quantities, except where an item is noted to be supplied "complete." The Contractor shall be paid for actual quantities, in place, as measured and agreed upon by the Engineer and Contractor. The Contractor shall be paid in full for items to be supplied "complete" when said item is finished, or at a percentage of the bid amount agreed upon by the Owner, Engineer and Contractor if the item is not complete.

**ITEM #1: PRE-CONSTRUCTION SURFACE TELEVISIONING**

This work consists of performing color video and audio recording of the project area and other areas which may be impacted by construction, specifically excavation or any work that requires backyard access.

Preconstruction video recordings will include coverage of the project area and all other areas which may be impacted by construction. Video recordings will also include construction easements when applicable. Video recordings will provide a visual record of all physical features within those areas, including, but not limited to, roadways, pavements, curbs, gutters, driveways, driveway aprons, sidewalks, carriage walks, parkways, trees, landscaping, shrubbery, plantings, landscaping walls, retaining walls, signs, sign posts, fences, utility poles, light poles, utilities, equipment, manholes, b-boxes, cleanouts, valves, curb structures, pipelines, buildings, mailboxes, and any other features located within the project area.

Video recordings will begin with an audio narrative which provides the current date and time, the name of Owner and name of project, and a description of both the starting location and the location or locations to be recorded, including street name or names, street addresses, and any additional information which may be necessary to describe the location and subject of viewing.

Video recordings will maintain viewer orientation by means of an audio commentary in the audio track of each video recording which provides an explanation of what is being viewed; and by videotaping landmarks and readily identifiable objects (property addresses, street signs, etc.) at appropriate intervals.

2019 SEWER REHABILITATION PROGRAM  
VILLAGE OF VILLA PARK

Preconstruction video recordings will be recorded at a rate of travel not exceeding 48 feet per minute, and zooming and panning rates will be controlled to provide clarity of features during playback. The finished product will be provided with bright, clear pictures and accurate colors free from distortion, tearing, rolls, or other forms of picture imperfection. The audio will have proper volume and clarity. All recordings will be performed at times of satisfactory visibility, and when no more than ten percent of ground is obscured by snow, leaves, or other cover.

If any element within or portion of the project area is not adequately documented by the preconstruction video recording so as to definitively demonstrate its condition prior to the start of construction, Contractor will assume responsibility for the repair, restoration or replacement of that element or portion of the project area. Such repair, restoration or replacement will be to equal or better condition than previously existing, and will further comply with all standards and provisions which govern the work in question.

**Schedule.** Pre-construction surface televising will be performed according to the following schedule:

- a. Pre-construction surface televising will take place after a Notice to Proceed has been issued.
- b. Pre-construction surface televising will take place after the Joint Utility Locating Information for Excavators (JULIE) request for the project area has cleared.
- c. Pre-construction surface televising will take place before any equipment, materials, or other items are delivered to the site.
- d. Pre-construction surface televising will take place no more than fourteen (14) chargeable days prior to the start of construction.
- e. The required pre-construction surface televising deliverables will be submitted to the Engineer, and the Engineer will review and issue written approval of the video before any activity other than utility locating will be permitted to start. Such activity will include, but not be limited to, delivery of materials and equipment, installation of traffic control and erosion control, and completion of construction layout and tree protection. No days will be charged against the contract time while the video is under review by the Engineer, including the day the deliverables are submitted and the day a response is provided. If the video or any portions thereof are rejected, the contract time will commence to run until revisions are submitted.
- f. The televising will be submitted to Engineer for review prior to commencement of any construction, and receive acceptance of recordings prior to commencement of construction. Any areas found not acceptable to the Owner will be re-filmed at no additional cost to the contract.

**Deliverables.**

Video will be high-definition, with a minimum resolution of 1280 x 720 pixels per frame. Video will be filmed in a landscape aspect ratio. Video filmed in a portrait aspect ratio will be considered unacceptable and will be rejected.

Pre-construction surface televising will be provided as electronic files of .avi, .mp4, .m4v, .mkv, .wmv, or .mpg file format, or of such other file format as may be approved by Engineer. Preconstruction video recordings will be provided as independent digital container format files, which container files will include all video, audio, and other electronic information necessary to view the preconstruction video recording as intended.

Pre-construction surface televising electronic files will be provided on a portable electronic media device or devices of one of the following types: USB flash drive, SD flash memory card, CF flash memory card, data DVD, external hard drive, or such other portable electronic media device as may be approved by Engineer. Pre-construction surface televising electronic files may also be provided via online file sharing, cloud storage, File Transfer Protocol (FTP), or other online or network file transfer methods if approved by Engineer.

Video DVD will be considered an unacceptable format for providing pre-construction surface televising, and will be rejected.

Pre-construction surface televising electronic files will be accompanied by corresponding logs which document the dates, times, and locations covered by each preconstruction video recording electronic file.

Contractor shall maintain copies of all items submitted to Engineer for Contractor's own use and record.

**Basis of Payment.** This work will be paid for at the contract Lump Sum price for PRE-CONSTRUCTION SURFACE TELEVISIONING.

**ITEM #2: PRE-CONSTRUCTION CLEANING AND TELEVISIONING**

**Description.** This section governs all work required for sewer cleaning and sewer inspection by closed circuit televising done in preparation for cured-in-place pipelining, grouting. Cleaning and televising shall be performed on the entire section of sewer between upstream and downstream manhole structures and shall be completed to the industry standard of 95% clean.

**Notice to Residents.** The Contractor shall provide and hang notices on doors of all residences and businesses with service lines connected to sewer mains to be cleaned. Notices shall be distributed 48 hours in advance of the work. The Contractor shall include the contact information for the onsite field supervisor as the primary contact for affected residents. The Village shall review and approve the notice format and text at the beginning

**2019 SEWER REHABILITATION PROGRAM  
VILLAGE OF VILLA PARK**

of the project prior to distribution. All work required for notification to residents shall be incidental to the contract.

**Equipment.** The Contractor is responsible to provide and maintain all industry-standard equipment required to complete the project. Each crew shall have a vacuum or jetter combination truck equipped with a high velocity gun for washing and scouring manholes and a TV truck capable of seating a minimum of 4 people including the Village and Engineer. For easement work, the Contractor shall be required to have off-road equipment as necessary to access off-street sewer areas.

If any equipment gets stuck in the sewer and needs to be dug up, the Contractor is solely responsible for the cost of the dig, complete restoration and repair of sewer and any other costs associated with the retrieval of the equipment.

1. Hydraulic Sewer Cleaning Equipment Requirements:

- a. Hydraulic sewer cleaning equipment shall be the movable dam type constructed such that a portion of the dam may be collapsed during cleaning to prevent flooding of the sewer.
- b. The movable dam shall be the same diameter as the pipe being cleaned and shall provide a flexible scraper around the outer periphery to ensure total removal of grease.
- c. The Contractor shall take special precautions against flooding prior to using sewer cleaning balls or other equipment that cannot be collapsed instantly.

2. High Velocity Hydro-Cleaning Equipment Requirements:

- a. A minimum of 700 feet of high pressure hose.
- b. Two or more high velocity nozzles capable of producing a scouring action from 10 degrees to 45 degrees in all size lines to be cleaned.
- c. A high velocity gun for washing and scouring manhole walls and floor with the capability of producing flows from a fine spray to a long distance solid stream.
- d. A 1,500-gallon minimum water tank, auxiliary engines and pumps, and a hydraulically driven hose reel.
- e. Equipment operating controls located above ground.
- f. Minimum working pressure of 1,000 pounds per square inch at a 50 gpm rate.

3. Mechanical Cleaning Equipment Requirements:

- a. Bucket Machines:
  - i. Furnish with buckets in pairs and with sufficient dragging power to perform the work efficiently.

**2019 SEWER REHABILITATION PROGRAM  
VILLAGE OF VILLA PARK**

- ii. Use V-belts for power transmission or have an overload device. No direct drive machines will be permitted.
  - iii. Be equipped with a take up drum and a minimum of 500 feet of cable.
- b. Rodding Machines:
- i. Either sectional or continuous.
  - ii. Hold a minimum of 750 feet of rod.
  - iii. The rod shall be specifically heat-treated steel.
  - iv. The machine shall be fully enclosed and have an automatic safety throw out clutch or relief valve.
- c. Lumberjack & Impact Cutters
- i. Lumberjack high speed low torque multi-purpose cutters
  - ii. Speeds up to 50,000 rpm
  - iii. Paikert low-speed, high-torque auger cutter
4. Closed Circuit Television Equipment:
- a. Television equipment shall include television camera, television monitor, cables, power source, lights and other equipment necessary to the televising operation. The television camera shall be specifically designed and constructed for operation in connection with sewer inspection and pipe joint sealing and testing.
  - b. Camera and lighting quality shall be suitable to provide a clear, continuously in-focus picture of the entire inside periphery of the sewer pipe for all conditions encountered during the work. The camera shall be able to operate efficiently in 100% humidity conditions.
  - c. The TV camera shall have a rotating head with a high resolution lens, capable of spanning 360-degrees circumference and 270-degrees on horizontal axis to televise sewer lines 6-inch diameter and larger. Focal distance shall be adjustable through a range of 1 inch to infinity. The purpose of the rotating head camera is to view all service connections, and to locate all defects, as well as any questionable problem areas. The camera shall be zoom capable.
  - d. The TV camera shall be equipped with remote control devices to adjust the light intensity and at a minimum one thousand (1,000) feet of continuous cable shall be provided. The camera shall be able to transmit a continuous image to the television monitor as it is being pulled through the sewer segments. Lighting system shall be adequate for quality pictures. A reflection in front of the camera may be required to enhance lighting.
  - e. For manholes that may be difficult to access or where lamp holes are present in the place of manholes, the Contractor shall have available a self-propelled crawler transporter on which to mount the color television camera so as to be able to inspect the sewer as required.

2019 SEWER REHABILITATION PROGRAM  
VILLAGE OF VILLA PARK

- f. The TV camera shall be able to provide a continuous image of not less than ninety five percent (95%) of the internal pipe surface at all times for sewers 8" through 48" in diameter. Maximum acceptable speed of camera through sewer shall be thirty (30) feet per minute.
- g. The camera, television monitor and other components of the video system shall be capable of producing a minimum 500 line resolution color video picture.
- h. Electronic media shall visually display and include a narrative noting:
  - i. Date, time of day, and depth of flow;
  - ii. Sewer segment number "from manhole to manhole";
  - iii. Distance from upstream manhole'
  - iv. Locations of service connections into sewer;
  - v. Location of obstructions, structural defects, joint deterioration, leakage or evidence thereof, and other abnormalities with respect to the sewer condition and distance in feet from the upstream manhole centerline.
- i. The remote reading footage counter shall be accurate to two-tenths of a foot over the length of the particular section being inspected and shall be mounted over the television monitor.
- j. Digital images should be provided in the common format accessible by Windows Media Player or approved equal.

**Sewer Cleaning.** The sewer manhole sections designated for sewer cleaning shall be cleaned using hydraulically propelled, high-velocity jet, or mechanically powered equipment. Selection of the equipment used shall be based on the conditions of the sewer lines at the time the work commences. The equipment and methods selected shall be satisfactory to the Engineer. Sewer cleaning shall consist of root cutting, removal of dirt, grease, rocks, sand and other materials and obstructions from sewer lines and manhole troughs. If cleaning of an entire section cannot be successfully performed from one manhole, the equipment shall be set on the other manhole and cleaning again attempted.

The Contractor shall perform all work in accordance with the latest OSHA confined space entry regulations.

Satisfactory precautions shall be taken to protect the sewer segments and sewer manholes from damage that might be inflicted by the improper use of cleaning equipment. Whenever hydraulically propelled cleaning tools, which depend upon water pressure to provide their cleaning force, or any tools which retard the flow of water in the sewer segment are used, precautions shall be taken to ensure that the water pressure created does not cause any damage or flooding to public or private property being served by the sewer segment involved.

2019 SEWER REHABILITATION PROGRAM  
VILLAGE OF VILLA PARK

When hydraulic or high velocity cleaning equipment is used, a suitable sand trap, weir, or dam shall be constructed in the downstream manhole in such a manner that all solids and debris are trapped and removed, thereby preventing such material from passing into the next sewer segment.

If conditions such as broken pipe and major blockages are encountered that prevent cleaning from being accomplished or where damage would result if cleaning were attempted or continued, the Contractor shall immediately notify the Engineer. The Engineer shall be notified of any conditions which warrant termination of cleaning activities.

**Root cutting.** Root cutting shall be required where it has been determined that root growth is substantial and cutting would be required to facilitate a thorough and complete examination of the condition of the sewer through internal closed circuit color television inspection.

The root cutting tools shall be the industry standard concave saws, flat saws, water blasters or chain knockers and shall be carefully selected to ensure no damage is caused to the sewer main or any portion of the lateral including protruding laterals. Extreme caution should be taken when operating root cutters in the sewer and a video inspection shall be on the root cutter at all times to ensure damage is not caused from root cutting.

Root cutting will be considered incidental to the Contract and will not be paid for separately.

**Debris Removal and Disposal.** The Contractor shall remove all sludge, dirt, sand, rocks, grease and other solid or semisolid material resulting from the cleaning operation from the downstream manhole of the sewer segment being cleaned prior to beginning television inspection. Passing material from sewer segment to sewer segment shall not be permitted. In the event that sludge, dirt, sand, rocks, grease and other solid or semisolid material resulting from the cleaning operation are observed and/or detected, as passing to downstream sewer segment(s), the Contractor shall clean such sewer segment(s) at no additional cost.

Debris catchers or baskets will be required to be set in the channel of the downstream manhole during all cleaning operations. Additionally, a "Vactor" or similar vacuum truck must be onsite during all cleaning operations and will be required to be setup on the downstream manhole to pull debris out of the sewer during all cleaning operations. As the sewer jet or other cleaning equipment is in use, the vacuum equipment shall be running in order to prevent debris from moving further downstream. The use of the vacuum truck does not constitute heavy cleaning.

When bucket machines are being used, a suitable container shall be provided to receive the materials dumped from the buckets. The Contractor at his discretion may use an approved container (roll off) for the storage of debris removed from the line segments. All material resulting from the cleaning operations shall be removed from the site when the

2019 SEWER REHABILITATION PROGRAM  
VILLAGE OF VILLA PARK

container has reached 3/4 of its volume, or at least once each working day and disposed of at the permitted disposal site.

Disposal of all sewer debris shall be the responsibility of the Contractor and shall be done in accordance with the Illinois Environmental Protection Agency (IEPA) and all other regulating agencies. Under no circumstances shall the removed sewage or solids be dumped onto streets or into ditches, catch basins, storm drains, sanitary, combined sewer manholes or otherwise improperly disposed. Improper disposal of sewage or solids removed from the sewers may subject the Contractor to fines imposed by the Village. In addition, the Contractor may be subject to civil and/or criminal penalties for improper disposal under the law. Removal and disposal of all sewer debris shall be incidental to the contract and will not be paid for separately.

**Internal Closed Circuit TV Inspection.** The Inspection of sewer lines by CCTV shall be performed on all lines prior to and after all rehabilitation work by trained experienced PACP certified personnel. The Contractor shall take all necessary measures to televise the internal surface of each sewer segment in its entirety.

The Contractor shall furnish all labor, electronic equipment and technicians schooled and licensed in PACP 6.0.1 format, to perform the closed circuit television inspection of the sewers. Operation of the equipment is to be controlled from above ground with a skilled technician at the control panel in the television studio, controlling the movement of the television camera through the sewer in either direction one segment at a time.

The video operator(s) shall be Pipeline Assessment Certification Program (PACP) certified by the National Association of Sewer Service Companies (NASSCO) and will be required to show proof of PACP ID or certification before performing work on this project. Certification dates must be current including renewal every three years. Operators with expired PACP ID numbers will not be allowed to work on the project until they have undergone the renewal process. The Contractor shall provide copies of each equipment operator's Certification Number at the preconstruction conference.

The Contractor shall begin each inspection with an onscreen written and verbal explanation of the project name, a detailed description of the location, the manhole to manhole segment, the direction of flow, the direction of camera setup and date. The depth (rim-invert) measurement of each manhole shall be recorded on the PDF report as well. A continuous footage counter shall be provided during the entire inspection, and shall be used to accurately record the locations of defects, connections, or objects in the pipe. The counter shall be accurate to two tenths of a foot. Maintain verbal commentary to identify any item that is called out on the report.

All inspections shall begin and end in the center of the manhole. The start of the video shall NOT begin already in the pipe segment. At the end of each inspection, the Contractor shall pan the camera around the ending manhole to get a view of what it looks like for identification purposes as well as documenting all incoming pipes.

2019 SEWER REHABILITATION PROGRAM  
VILLAGE OF VILLA PARK

The camera shall be moved through the line in either direction at a uniform rate of no more than 30 feet per minute, stopping when necessary to ensure proper documentation of the sewer's condition. The Contractor shall take all necessary measures to televise 95% of the internal surface of each sewer segment in its entirety. If dewatering with the jet truck is required to see 95% of the pipe, this shall be done at no additional charge to the Village. Lighting system shall be adequate for quality pictures. A reflection in front of the camera may be required to enhance lighting.

If any obstruction in the sewer segment such as a protruding building lateral prohibits the passage of the television camera, the Contractor shall attempt to inspect the remainder of the sewer segments by making a reverse set up at the next downstream manhole. No additional payment shall be made for reverse setups.

All obstructions in the sewer segment that prohibit passage of the television camera shall be immediately reported to the Engineer by the Contractor referencing the location and nature of the obstruction.

The Contractor shall be responsible for any damage to public or private property resulting from his/her televising activities and shall repair or otherwise make whole such damage at no cost to the Village.

**Digital Video & Report Deliverables.** Electronic media of all sections shall be provided to the Village together with the respective television inspection reports. TV reports shall legibly show the location of each point of significance in relation to an identified manhole. Points of significance are, but not limited to the following: private service connections, unusual conditions, roots, storm sewer connections, sags, grease, broken pipe, presence of scale and corrosion, structural failures and other discernable features.

The Contractor shall provide a color digital video of all pipe line segments in ".mpeg" format on two (2) external hard drives with USB 2.0 connections. Each video shall be named according to the "upstream manhole number – downstream number.mpg" format. For example, a pipe segment video with an upstream manhole of 12345 and downstream manhole 67890 would be named "12345 - 67890.mpg". Separate MPEG files and PDF reports shall be created for each manhole to manhole pipe segment inspected.

Video recordings shall be one file per sewer line section and shall be included on the external hard drives submitted. Total drives submitted for final acceptance at the end of the project shall be two (2).

The pipeline inspection shall consist of identifying a location both within the pipe segment (physical location) and within the digital recording (video frame location) for each defect or observation. The use of time codes for defect location shall NOT be deemed equivalent or acceptable. The digital recording and inspection data is to be cross-referenced for instant access to any point of interest within the digital recording. The inspection information shall include the digital recording of video and audio, segment identification information (starting manhole, date, time, etc.) including a pointer from each observation

**2019 SEWER REHABILITATION PROGRAM  
VILLAGE OF VILLA PARK**

to the digital recording (video frame number), and any accompanying digital still images (JPEG or BMP).

Any out-of-focus video recordings, or portions thereof, shall be cause for rejection of the video recording and will necessitate re-televising at the Contractor's expense. Televising shall be done one section at a time. Inspections shall be performed using NASSCO's PACP version 7.0.2. The sewer pipe video inspection reports must be saved with the PACP overview report.

Audio and video observation documentation is to be provided in the most up-to-date form of a NASSCO PACP (V7.0.2) coding methodology database. The PACP Version 7.0.2 data base shall include all header information as well as any observations recorded. Links to the videos and the ".pdf" format of the reports shall be included within the database. This database shall be updated monthly and shall contain every observation from the beginning of the project through current delivery date.

The deliverable video files shall be full-color, high-resolution, and shall include all pipe surfaces above the water line. At each lateral and connected service line, the camera shall stop, rotate, and record a clear image of the lateral or service line to determine condition and if it is active or inactive. The inspection and database shall be fully compatible with PACP V7.0.2 format.

Contractor shall record inspection in a PACP format. Video recordings and inspection shall visually display and include a narrative noting:

1. Date, time of day, and depth of flow
2. Sewer segment number "from manhole to manhole"
3. Direction of Flow
4. Distance from upstream manhole'
5. Locations of service connections into sewer;
6. All other information encountered during the inspection i. e obstructions, structural defects, leakage, sags, collapses etc.

The television inspection reports shall be provided both electronically in Adobe Acrobat Reader ".pdf" format as well as two bound hardcopies of the printed paper report. The file naming format shall follow a similar format to the video naming format. The final report files, in paper and electronic ".pdf" formats, shall include a still shot image of every observation. These detailed reports shall include the following information at a minimum:

- Project Name
- System Owner Name
- Survey Customer Name
- Contractor Name, Phone Number & Address

**2019 SEWER REHABILITATION PROGRAM  
VILLAGE OF VILLA PARK**

- Surveyor's Name & PACP Certification Number
- Date and Time of Televising
- Location (Street Name and Number)
- Address (nearest to each manhole)
- Pipe Segment ID Number
- Upstream Manhole Number & Downstream Manhole Number
- Manhole Depth
- Segment Length
- Joint Length
- Pipe Material
- Pipe Height (and Width if not Circular)
- Total Pipe Length
- Total Length Surveyed
- Tape/Media Number
- Pre-Cleaning / Cleaning method
- Pipe condition observations (i.e. grease, roots, deposits, cracks, fractures, sags voids etc.)
- Location of all service connections (description of active vs. inactive)
- Location of all manholes
- NASSCO – Structural, O&M and Overall Ratings

**Basis of Payment.** Sewer cleaning and television inspection in preparation for rehabilitation work shall be paid for at the Contract Unit Price per Linear Foot for PRE-CONSTRUCTION CLEANING AND TELEVISIONING.

**ITEM #3: LATERAL CLEANING AND TELEVISIONING**

**Description.** Each lateral receiving a T-Liner shall be cleaned and televised prior to lining. The purpose of the lateral televising is to record the before lining conditions and ensure that the lateral will be able to receive the T-liner. Lateral televising is limited to the amount necessary to ensure the proper installation of the 5-foot T-Liner. The digital database of the lateral TV shall be provided to the Engineer for review before the lateral can be approved for lining.

2019 SEWER REHABILITATION PROGRAM  
VILLAGE OF VILLA PARK

The work shall include cleaning lateral, root cutting and removal/disposal of debris, mineral deposits, grease and sewerage solids, televising and submission of digital database prior the liner installation.

Contractor shall provide an LACP coded report and video.

**Basis of Payment.** Lateral cleaning and televising shall be paid for at the Contract Unit Price per Each for LATERAL CLEANING AND TELEVISIONING.

**ITEMS #4 THRU #9: CURED-IN-PLACE SEWER LINER, AND INTERNAL SERVICE  
LATERAL REINSTATEMENT**

**Description.** This work shall include the repair of defective sewer by the installation of a resin impregnated flexible felt tube in all segments as shown on the plans. The tube shall be saturated with a thermosetting resin and installed into the existing sewer using an inversion process. Curing shall be accomplished by circulating hot water or steam to cure the resin into a hard impermeable cured-in-place pipe. When cured, the liner shall be a continuous tight fitting watertight pipe-within-a-pipe.

This specification references American Society for Testing and Materials (ASTM) standard specifications, Insituform of North America, Inc. (INA), and Inliner USA, Inc., or the Village approved equal, manufacturer's standards which are made a part hereof by such reference and shall be the latest edition and revision thereof.

**Materials.** The Tube shall consist of one or more layers of a flexible needled felt or an equivalent nonwoven or woven material, or a combination of nonwoven and woven materials, capable of carrying resin and withstanding the installation pressures and curing temperatures. The tube should be compatible with the resin system to be used on this project. The material should be able to stretch to fit irregular pipe sections and negotiate bends.

The tube should be fabricated to a size that, when installed, will tightly fit the internal circumference and the length of the original conduit. Allowances should be made for the longitudinal and circumferential stretching that occurs during placement of the tube. The tube shall be uniform in thickness and when subjected to the installation pressures will meet or exceed the designed finish wall thickness. The tube shall be marked for distance at regular intervals along its entire length, not to exceed 5 feet. Such markings shall also include the lining manufacturer's name or identifying symbol.

Any plastic film (including polyethylene, polyurethane, and polypropylene layers) applied to the tube on what will become the interior wall of the finished Cured-In-Place Pipe (CIPP) shall be compatible with the resin system used, translucent enough that the resin is clearly visible, firmly bonded to the felt material, and shall be capable of withstanding installation pressures and curing temperatures.

The resin system shall be a corrosion resistant polyester, vinyl ester, or epoxy and catalyst system that when properly cured meets the minimum requirements given herein or those that are to be utilized in the design of the CIPP for this project. The manufacturer shall be Insituform, Inliner USA, National Liner or an approved equal.

**Sizing of the Liner.** The liner shall be fabricated to a size that when installed will neatly fit the internal circumference of the sewer to be lined. Allowance for circumferential stretching of the liner during insertion shall be made as per manufacturer's standards. The length of the liner shall be that deemed necessary by the Contractor to effectively carry out the insertion and seal the liner at the inlet and outlet points. The Contractor shall verify the lengths in the field. Individual installation runs can be made over one or more access points as determined in the field by the Contractor and approved by the Engineer.

The liner thickness shall be based on the condition of the existing pipe which shall be classified as fully deteriorated pipe and structurally unsound. The liner shall be designed to withstand all imposed loads. The liner thickness shall have sufficient wall thickness to withstand the anticipated external pressures and loads which will be imposed after installation. The design of the liner shall include considerations for ring bending, deflection, combined loading, buckling, and ovality. Liner thickness shall be based on the use of the standard flexible pipe equations, as detailed in ASTM F-1216 and shall account for the effects of ovality. A minimum cured wall thickness of 6 mm (+/- 10%) shall be used for pipes up to and including 15" and a minimum cured wall thickness of 7 mm shall be used for pipes 18" and above. The Contractor shall use wall thickness appropriate to the depth of pipe being lined. A safety factor of at least 1.5 shall be utilized.

**Structural Requirements.** The materials properties of the finished CIPP shall meet or exceed the following structural standards:

Minimum Physical Properties

Property	ASTM Test Method	Polyester System	Filled Polyester System	Vinyl Ester System
Flexural Strength	D790	4,500 psi	4,500 psi	5,000 psi
Flexural Modulus (Initial)	D790	250,000 psi	400,000 psi	300,000 psi
Flexural Modulus (50 Yr)	D790	125,000 psi	200,000 psi	150,000 psi
Tensile Strength	D638	3,000 psi	3,000 psi	4,000 psi

**Execution.** Installation shall be in accordance with standard practice for rehabilitation of existing pipelines and conduits and curing of a resin – impregnated tube ASTM F-1216. The Contractor may use either hot water or steam cure as deemed necessary for the

2019 SEWER REHABILITATION PROGRAM  
VILLAGE OF VILLA PARK

installation, however specific installations may warrant the designation of a certain curing method and the Contractor is to allow for the installation using either technique.

The Contractor when required shall provide for the transfer of flow around the section or sections of pipe that are to be lined. The bypass shall be made by diversion of the flow at an existing upstream access point and pumping the flow into a downstream access point or adjacent system. The pump and bypass lines shall be of adequate capacity and size to handle the flow. The proposed bypassing system shall be approved in advance by the Village.

No lining will be permitted during periods of high flow.

Prior to any lining of designated sanitary sewer line segments the Contractor shall remove internal deposits and roots as necessary to assure proper liner installation. Television inspection shall be performed to verify extent of damage, and location of service connections. Cleaning and inspection shall be in accordance with these specifications.

**Public Notice.** A public notification program shall be implemented, and shall as a minimum, require the Contractor to be responsible for contacting each home or business connected to the sanitary sewer and informing them of the work to be conducted, and when the sewer will be off-line. The Contractor shall also provide the following:

1. Written notice to be delivered to each home or business describing the work, schedule, how it affects them, and a local telephone number of the Contractor they can call to discuss the project or any problems that could arise.
2. Personal contact and attempted written notice 24-48 hours prior to the beginning of work being conducted on the section of sewer relative to the residents affected.
3. Personal contact with any home or business that cannot be reconnected within the time stated in the written notice.

**Flexible Liner Installation.** The Contractor shall designate a location where the uncured resin in the original containers and the un-impregnated fiber felt tube will be vacuum impregnated prior to installation. The Contractor shall allow the Engineer to inspect the materials and procedure. A resin and catalyst system compatible with the requirement of this method shall be used. The quantities of the liquid thermosetting materials shall be per manufacturer's standards to provide the lining thickness specified and shall be sufficient to fill the volume of air voids in the tube with additional allowances being made for polymerization shrinkage and the anticipated loss of any resin through cracks and irregularities in the original pipe wall.

The wet out (inversion) fiber felt tube shall be inserted through an existing manhole or other approved access point. The manufacturer's standards shall be closely followed during the elevated curing temperatures so as not to over stress the felt fiber and cause damage or failure during the cure.

2019 SEWER REHABILITATION PROGRAM  
VILLAGE OF VILLA PARK

If the Contractor installs a shot through an existing manhole, it is the Village's intention for the Contractor to provide a liner through the manhole channel. The Contractor shall extend the liner to cover as much of the manhole channel as possible. The liner seam, along the manhole bottom, between bench and trough, shall be sealed with an epoxy compatible with CIPP resin.

The finished cured-in-place pipe shall be continuous over the entire length of the insertion run and be as free as commercially practicable from significant defects. Any defects which will affect, in the foreseeable future, or warranty period, the integrity, maintenance, or strength of the cured-in-place pipe, including foreign inclusions, dry spots, pinholes, delaminations, wrinkles, bubbles and blisters shall be repaired at Contractor's expense, in a manner mutually agreed upon by the Village and the Contractor.

**End Seal.** All pipes shall be fitted with a hydrophilic gasket, the "Insignia" as manufactured by LMK or approved equal, at both ends of each segment prior to installation of the liner. In addition, the liner shall be neatly cut at least 4-inches from the manhole wall to allow for filling of the annular space at the manhole opening with an epoxy resin compatible to CIPP. This epoxy resin filling, along with a hand brushed hydraulic cement topcoat, shall be applied at all manhole wall to CIPP joints to ensure a water tight seal at the manhole. The cost for this work shall be incidental to the cured-in-place pipelining.

**Lateral Reinstatements.** After the cured-in-place pipe has been cured, the Contractor shall reconnect the existing active branch or service lines as designated by the Village. This shall be done without excavation and in the case of non-man entry pipes, from the interior of the pipelines by means of a television camera and a remote cutting device that re-establishes them to not less than 95 percent capacity and not more than 100% of the internal diameter of the lateral pipe. The surface of the opening shall be wire brushed to remove extraneous material and provide a smooth edge at each lateral connection.

**Testing.** The Contractor shall prepare a sample for each installation of CIPP. The samples shall be restrained samples for diameters of CIPP less than 18"; and flat plate samples for diameters of CIPP 18" and larger. The flat plate samples shall be taken directly from the wet out tube, clamped between flat plates, and cured in the downtube. The restrained samples shall be tested for thickness and initial physical properties; flat plate samples shall be tested for initial physical properties only. The Contractor shall be responsible for providing one data set for each week of installation (testing sample to be determined by the Engineer). If that data set does not meet the testing criteria then all remaining samples for that week shall be tested for compliance and the liners not meeting the design criteria shall be rejected for payment and removed at the Contractor's expense.

The post-installation television inspection shall be used to confirm tightness of fit of the CIPP to the host pipe and to identify any imperfections; the finished liner shall be continuous over its entire length and to be free from visual defects such as foreign inclusions, dry spots, pinholes, delaminations, wrinkles, bubbles and blisters. All defects discovered during the post-installation television inspection shall be corrected by the

2019 SEWER REHABILITATION PROGRAM  
VILLAGE OF VILLA PARK

Contractor at no additional cost, prior to completion of work. After defects are corrected, the sewer shall be televised again to show effectiveness of repairs.

The work for sewer televising post-liner installation shall be incidental to the cost item.

**Basis of Payment.** The work will be paid for at the Contract Unit Price per Linear Foot for CURED-IN-PLACE SEWER LINER of diameter specified. Measurement shall be made from face of upstream manhole to face of downstream manhole unless the Contractor undertakes a "double" shot in which case the length through the intermediate manhole shall be included.

Internal service lateral reinstatements shall be paid for at the Contract Unit Price per Each for INTERNAL SERVICE LATERAL REINSTATEMENT.

**ITEM #10: PROTRUDING TAP REMOVAL**

**Description.** For break-in service connections that protrude more than one inch into the sewer, the Contractor shall remove the protruding portion of the tap in preparation for cured-in-place pipelining, grouting or other rehabilitation work. Cutters used shall be power-driven cutting devices (lateral cutters) designed to remove protruding taps. Cutters shall be capable of slicing laterally through cast iron, 3/4" rebar and anchors, clay tile, and concrete protruding into sewer lines. Any other method of protruding tap removal must be approved by the Engineer or the Owner

The Contractor shall cut protruding taps so that protrusions are no greater than 1/2 inch. While using a protruding tap cutter, slow RPM will cut more effectively than rapid RPM. The Contractor shall maintain a steady flow and RPM while cutting and shall hydro-flush cut and broken pieces out of the sewer before proceeding to the next protruding tap. The TV operator shall pan up the service before the tap is cut to show the existing conditions of the service. All tap cutting shall be performed during televising operations. After the tap is cut, the TV operator shall pan up the service to show the extents of the cutting. If a protruding tap cannot be removed by the cutting device, then the Engineer shall be notified to determine if a point repair will be necessary. Obtain authorization from the Engineer before proceeding.

**Basis of Payment.** This work item shall be paid at the Contract Unit Price per Each for PROTRUDING TAP REMOVAL and shall include all material, and labor required. Protruding taps shall be cut with approved lateral cutters and shall not be cut with root saws. Any damages caused to the sewer main or sewer service lateral during tap cutting shall be the responsibility of the Contractor and shall be repaired at no additional expense to the Village.

**ITEM #11: DYE TESTING OF EXISTING SERVICE CONNECTIONS**

**Description.** Only one lateral reinstatement per property shall be allowed during cured-in-place pipelining unless otherwise approved in advance by the Village. Any properties with more than one lateral shall be identified during PRE-CONSTRUCTION CLEANING

2019 SEWER REHABILITATION PROGRAM  
VILLAGE OF VILLA PARK

AND TELEVISIONING and shall be dye tested by the Contractor to verify active or abandoned connections to the sewer, prior to cured-in-place pipelining. This work includes contacting the homeowners, coordinating and performing the dye test, as well as presenting the findings to the Engineer and the Village. If the property cannot be dye tested, the Contractor shall notify the Engineer immediately. Additional lateral connections with visible caps shall not warrant dye testing and shall be left closed without reinstatement. The Contractor shall layout services only where services are dye tested.

In addition to dye testing properties with more than one lateral, the Contractor shall layout locations of services for any sewer segments that have more active lateral connections than houses on the same stretch. The Contractor shall utilize a measuring wheel or tape to measure from the manhole and locate each service lateral point based on camera reel counter footage. This layout shall aid in confirmation that the correct service location is marked and being re-instated. The Contractor shall paint the location of services in an oil-based white paint for paved areas.

If there is question as to whether a connection is active or abandoned, all video, layout, dye test and other pertinent information shall be presented to the Engineer and the Village for a decision on reinstatement prior to cured-in-place pipelining. All dye testing and layout results shall be presented to the Engineer and the Village to verify results.

**Basis of Payment.** This work shall be paid for at the Contract Unit Price per Each for DYE TESTING OF EXISTING SERVICE CONNECTIONS.

**ITEMS #12: AIR TEST AND GROUT SERVICE CONNECTION**

**General.** This work shall consist of testing and grouting of sanitary service connections. Locations for service connection grouting shall be identified by pressure testing all service lateral connections and then sealing the lateral connections that fail the pressure test. Locations selected shall be approved by the Engineer in advance of performing any service lateral grouting. All grouting of service laterals shall be completed prior to the final post televising of the sewer segment.

**Materials.**

1. **Chemical Grout Materials:** The sealing materials shall be a chemical grout and catalyst system. The chemical grout used shall have a documented service of satisfactory performance in similar usage. The materials shall be the chemical grout AV-100 with recommended catalysts and other materials as distributed by Avanti International or approved equal.
2. **Basic Chemical Grout:** The chemical grout shall consist of an intimate mixture of dry acrylamide and dry N, N' – Methylenebiscacrylamide in such proportions that dilute aqueous solutions, when properly catalyzed will form stiff gels. The grout must make a true solution at concentrations as high as three pounds per gallon of water. The chemical solutions shall have the ability to tolerate ground water dilution

2019 SEWER REHABILITATION PROGRAM  
VILLAGE OF VILLA PARK

and to react in moving water and shall have a low viscosity which shall remain constant until gelation occurs. The reaction time shall be controllable from 10 seconds to an hour, at temperatures from ambient to freezing and up to three hours at temperatures up to 140 degrees F. The reaction shall produce a continuous and irreversible gel at chemical concentrations as low as 0.4 pounds per gallon of water.

3. Catalyst: The catalyst for the chemical grout shall be ammonium persulfate.
4. Activator: The activator shall be Triethanolamine "T" or other suitable compounds. Activators shall be used with the catalyst for all applications at ambient temperatures or below.
5. Inhibitor: Under some conditions it may be necessary or desirable to control the chemical reaction by inhibitors. The inhibitor used shall be potassium ferricyanide.
6. Buffer: Disodium phosphate pentahydrate shall be used for pH control when the catalyst is used without activator (this will normally be only at elevated temperatures).
7. Additives: It may be found advisable to include additives to lower freezing temperatures or give more rapid gel, or insoluble materials as a filler or to give strength. If the Engineer or the Contractor finds such additives desirable, they may be included if specifically recommended by the grout manufacturer and approved by the Engineer.

**Mixing and Handling.** The chemical grout shall be stored in sealed containers apart from any additives or petroleum products. When mixing the following will be required:

- Disposable surgical gloves
- Rubber steel toed boots
- Cartridge respirator with Hepa filter
- Goggles or face shield
- Tyvex suit
- Exhaust fan to be turned on prior to mixing
- Tanks are to be filled with water to the proper level for batch mix
- Bag of chemical grout material shall be opened carefully to expose long neck of inner bag. Long neck is to be submerged below water level in tank and the grout material dumped in underwater thus eliminating dust.
- Additives such as ammonium persulfate and triethanolamine shall be introduced into the liquid slowly and in small amounts to avoid splashing
- Upon completing the mix, the gasketed tank lids shall be secured.

**Concentration of mix.** The concentration of the basic chemical grout (computed as a dry weight percentage of the total solution weight) shall generally range between 10 percent

2019 SEWER REHABILITATION PROGRAM  
VILLAGE OF VILLA PARK

and 12 percent. In no case shall the concentration be less than 6 percent, and it may go as high as 20 percent where additional strength is required.

**Diatomaceous Material.** When excessive amounts of chemical grout is used due to large stone back-fill or voided surroundings, a filler such as "Diatomaceous Earth" or approved equal may be used within the chemical grout material, increasing its density and providing better control for the placement of the chemical grout. The maximum of 10 percent by weight can be added to the chemical grout solutions. The "Diatomaceous Earth" additive will not constitute changing any percentage of the basic chemical grout mixture as recommended by the manufacturer.

**Root Control.** Should root conditions be encountered in sewer lines and/or service laterals, a root killer such as Barrier 50 shall be used to kill and further deter root growth. The root killing chemical shall be added to the chemical grout mixture and shall have the ability to remain active within the grout for a minimum of 12 months.

**Construction Requirements.** Service lateral connections shall be grouted in accordance with the provisions provided in these specifications. Lateral connections selected for GROUT SERVICE CONNECTIONS shall be identified by pressure testing the service lateral connection and then sealing the lateral connections that fail the pressure test. Locations selected shall be approved by the Engineer in advance to performing any service lateral grouting. All grouting of service laterals shall be completed prior to the final post televising of the sewer segment.

For each service lateral within the project, the Contractor shall pressure test the service lateral connection and seal the failed lateral connections. For factory tees and wyes, the test and seal shall include the first joint upstream of the mainline sewer, including a minimum distance of five (5) feet from the main. For break-in connections, the test and seal shall include the break-in and the first joint upstream of the mainline sewer, also including a minimum distance of five (5) feet from the connection to the main.

The Contractor shall apply air pressure of 0.5 psig per vertical foot of sewer depth plus an additional 2.0 psig (total pressure not exceeding 10 psig). The test pressure and pipeline depth shall be recorded. If the air pressure on the lateral connection drops 1.0 psig within a 15-second time period, the connection "fails" the test and requires sealing as specified herein.

The Contractor will be required to retest failed connections after the sealing procedure is completed to verify effectiveness of the sealing. This shall be done by first deflating the packer ends until the "void" pressure meter reads zero pressure. The Contractor shall clean the equipment of residual grout. Once equipment is clean the Contractor shall re-inflate the packer ends and apply test pressure again. Grouted connections failing the pressure test shall be resealed and retested until each connection passes the air test.

Complete records shall be kept of lateral connections sealing performed in each sewer section. The records shall identify the manhole to manhole section in which the testing

**2019 SEWER REHABILITATION PROGRAM  
VILLAGE OF VILLA PARK**

and sealing was done, the location and type of each lateral connection tested and/or sealed, whether there is visible evidence of infiltration and inflow at each service connection and an estimated flow rate in gallons per minute, any problems with the service connection i.e. roots, grease, etc, the test pressure before and after sealing, the quantity of chemical sealing material used at each lateral connection in gallons, the chemical set time and materials including any additives, and the lateral connection sealing verification results. PDF reports for each sewer segment tested and sealed shall be included on the final hard-drive deliverable.

The Contractor shall be required at a minimum, to apply one gallon of grout per foot of sealing distance for each lateral connection. During grouting operations the Contractor shall televise the lateral connection testing and sealing and provide one digital video file for each sewer section containing service lateral testing/sealing. This digital video file is to be included on the final hard-drive deliverable.

Any excess grout that remains in the sewer main shall be removed by the Contractor. The Contractor shall perform an air test on the service lateral and/or flush test from the residence to confirm that the service lateral is open for sewerage flow. The Contractor shall be solely responsible and liable for any property damages resulting from the grouting work.

The Contractor will not be allowed to flush sealing chemicals into the downstream pipe reaches and shall dispose of unplaced and waste chemical sealing material and all equipment cleaning chemicals off-site, in accordance with IEPA requirements. The Contractor will not be allowed to discharge within the Municipal limits or in the sanitary sewer.

Testing and grouting of service lateral will be measured for payment by count of approved service laterals tested and grouted.

**Basis of Payment.** This work will be paid for at the Contract Unit Price per Each for AIR TEST AND GROUT SERVICE CONNECTION, and shall include up to five (5) feet of lateral.

**ITEMS #13 & #14: T-LINER INSTALLATION**

**General.** The Contractor shall repair defective mainline to lateral connections with LMK T-liners, or an approved equal, that extend 5' up into the service lateral. Installation shall be a cured-in-place pipe (CIPP) inversion method using an approved full wrap T-liner system.

**Materials.** The liner assembly shall be continuous in length and consist of one or more layers of absorbent textile material i.e. needle punched felt, circular knit or circular braid that meet the requirements of ASTM F1216 and ASTM D5813 Sections 6 and 8. The textile tube and sheet shall be constructed to withstand installation pressures, have

**2019 SEWER REHABILITATION PROGRAM  
VILLAGE OF VILLA PARK**

sufficient strength to bridge missing pipe segments, and flexibility to fit irregular pipe sections. The wet-out textile tube and sheet shall meet ASTM F 1216, 7. 2 as applicable, and shall have a uniform thickness and 5% to 10% excess resin distribution that when compressed at installation pressures will meet or exceed the design thickness after cure. The mainline tube shall include a seamless molded flange shaped (aka Hydrohat) gasket attached to the main liner tube at the connection and four molded hydrophilic O-rings at the mainline termination ends. The gasket(s) must be a minimum of 2.5mm thick and must retain this consistent thickness under installation pressures. The lateral tube shall include two compression molded O-ring gaskets attached six-inches from the terminating end of the lateral tube. Hydrophilic O-Rings between the liner and the host pipe shall be LMK Insignia or approved equal. Mainline tube shall also include hydrophilic O-Rings at both end.

The mainsheet and lateral tube shall be a one-piece assembly formed in the shape of a "T" or WYE. No intermediate or encapsulated elastomeric layers shall be in the textile that may cause de-lamination in the cured in-place pipe. The main sheet will be flat with one end overlapping the second end and sized accordingly to create a circular lining equal to the inner diameter of the main pipe. The lateral tube will be continuous in length and the wall thickness shall be uniform. The lateral tube will be capable of conforming to offset joints, bells, and disfigured pipe sections.

The resin/liner system shall conform to ASTM D5813 Section 8. 2. 2 - 10,000 hour test. The resin shall be a corrosion resistant polyester, vinyl ester, epoxy or silicate resin and catalyst system that when properly cured within the composite liner assembly, meets the requirements of ASTM F1216, the physical properties herein, and those which are to be utilized in the design of the CIPP, for this project. The resin shall produce CIPP, which will comply with the structural and chemical resistance requirements of ASTM F1216.

**Table 1 CIPP INITIAL STRUCTURAL PROPERTIES**

Property	ASTM Test	Minimum Value	
		PSI	(Mpa)
Flexural Strength	D 790	4,500	(31)
Flexural Modulus	D 790	250,000	(1,724)

The CIPP shall be designed per ASTM F1216, Appendix X1.

The CIPP design for the lateral tube shall assume no bonding to the original pipe.

**Cleaning and Televising.** The lateral shall be cleaned and televised prior to the installation of the liner. The digital video of the lateral shall be provided to the Engineer for review before the lateral can be approved for lining. This work will be paid for separately.

**T-Liner Installation.** Installation shall be accomplished by the use of a resin impregnated one-piece main and lateral lining and by means of air inflation and inversion. The liner is

2019 SEWER REHABILITATION PROGRAM  
VILLAGE OF VILLA PARK

pressed against the host pipe by pressurizing a bladder that is held in place until the thermo-set resins have cured. When cured, the liner shall extend over a predetermined length of the service lateral and a particular section of the main pipe as a continuous, one piece, tight fitting, corrosion resistant and verifiable non-leaking cured in-place pipe.

The outside layer of the textile tube (before inversion) and interior of the textile sheet shall be coated with an impermeable, translucent flexible membrane. The textile sheet before insertion shall be permanently marked as a "Lateral Identification" correlating to the address of the building and the lateral pipe services. The sheet and tube shall be surrounded by a second impermeable, flexible translucent membrane (translucent bladder) that will contain the resin and facilitate vacuum impregnation while monitoring of the resin saturation during the resin impregnation (wet-out) procedure.

The mainline liner and bladder shall be wrapped around the "T" launching device and held firmly in place. The Main/Lateral bladder assembly shall extend past all ends of the liner, as no cutting shall be required.

The finished CIPP shall be continuous over the entire length of the rehabilitated sewer service lateral and 12" of the main pipe. The CIPP shall be smooth with minimal wrinkling and shall be free of dry spots, lifts, and delaminations. After the work is completed, the installer will provide the Village with video footage documenting each repair. The finished product must provide an airtight, watertight verifiable non-leaking connection between the main sewer and sewer service lateral. Upon completion, the installer will deliver digital video and a digital database (external hard drive) of the completed work to the Engineer. The Engineer will review the documentation and the site to determine that the scope of work is complete and the work is satisfactory.

**Basis of Payment.** This work will be paid for at the Contract Unit Price per Each for T-LINER INSTALLATION, of the sewer main and lateral service diameters specified, and shall include up to five (5) feet of lateral.

Installation of lateral liner over five (5) feet shall be paid at the Contract Unit Price per Linear Foot for ADDITIONAL LATERAL LINER.

**ITEM #15 TO #23: POINT REPAIRS**

This work shall consist of the removal and replacement of portions of sanitary sewer pipe and all necessary removal and restoration of existing surface and utilities at locations show on the Plans. Work and materials incidental to POINT REPAIR may include, but are not limited to: excavation, shoring, sheeting, bracing, all pipes, fittings, adapters, pipe bedding, trench backfill, temporary aggregate, surface restoration and traffic control.

The existing surface area of each work location shall be recorded in electronic media format prior to any excavation as described in PRE-CONSTRUCTION SURFACE

2019 SEWER REHABILITATION PROGRAM  
VILLAGE OF VILLA PARK

TELEVISIONING. Site preparation including surface removal shall be as required for each individual point repair. The Contractor shall verify pipe size and type prior to construction.

**Materials:** Pipes installed during point repairs shall conform to the following requirements and shall be free of visible cracks, holes, foreign material, blisters, or other deleterious faults.

PVC Sewer Pipe and Fittings:

1. 6 to 12 inch diameter:
  - a. ASTM D2241- SDR 26
2. Service pipes are to match sewer main.
3. Fittings such as saddles, elbows, tees, and wyes shall be factory produced and have joint design compatible with adjacent pipe.
4. Transitions to existing pipe materials: Non-shear couplings with stainless band are required for connecting to existing sewer pipe, and shall conform to ASTM C-1173. They shall be Fernco RC series or Flex-Seal adjustable repair couplings or approved equal.
5. Joints/Rubber Gasket: Conform to ASTM F477. Bell and spigot joint conforming to ASTM D3139, sealed by rubber gasket so assembly remains watertight under conditions of service including movements resulting from expansion, contraction, settlement, and deformation of pipe.
6. Field applied heat fusion or solvent welded joints between pipe sections, pipe and fittings or fitting components shall not be permitted.
7. Assembled joint shall pass performance tests as required in ASTM D3139.
8. Pipe Markings:
  - a. Manufacturer's name or trademark.
  - b. Nominal pipe size.
  - c. PVC cell classification
  - d. ASTM D2241 SDR 26
  - e. Extrusion date, period of manufacture or lot number.

**Execution:** Replacement pipe shall be placed in the same line and grade of the existing pipe sections. The condition of the pipe sections upstream and downstream of the specified repair location shall be inspected and, if defective, the Engineer will determine if additional repairs are necessary. If additional pipe repairs of five feet or less are required, no additional compensation shall be made.

When specified repairs cannot be made because of physical limitations at the site, the Engineer shall be promptly notified. Alternate repair techniques shall be evaluated in cases where conventional repairs are not practical. Change orders may be required for alternate repairs. Sewer line repair pits shall remain uncovered until an inspection by the Engineer has been made.

2019 SEWER REHABILITATION PROGRAM  
VILLAGE OF VILLA PARK

1. Excavate repair pit and uncover the main line sewer a minimum of one foot clearance all around at the damaged section or as directed by the Engineer, and remove damaged pipe.
2. Defective pipe sections and service connections shall be removed by cutting the pipe past the bell end, if necessary, to allow for the use of rubber coupling. Replacement pipe lengths shall be cut to within one-fourth inch of the required replacement pipe length and attached to the existing pipe with appropriate sized rubber couplings. Defective service connections shall be replaced with appropriate sized wye connection and rubber couplings. Pipe bedding under the replacement pipe section shall be compacted to prevent settlement and provide support.
3. Sanitary service connection shall include up to ten (10) feet of the service measured from the wye joint. Connect ends of new service piping to existing piping using non-shear shielded rubber mission coupling connectors.
4. Replacement of sanitary service connections shall include the filling of any voids which may be found to exist around the lateral. The void space shall be filled with hydraulic cement or other approved material for a minimum distance of three feet.
5. Where the existing service lateral pipe is found to be in such a deteriorated condition that the specified reconnection cannot be made, the Engineer and Village shall both be notified by the Contractor.
6. When multiple lateral services exist at an address, the Contractor shall determine if lateral is live. Only live laterals are to be reconnected. Dead laterals will be removed.
7. Seal joints within the repair pit that appear to be open or in poor condition but the barrel of the pipe is still good. Roots in open joints shall be removed before sealing. All determinations for sealing joints shall be made by the Engineer. Joints that are open or in poor condition shall be cleaned and packed with a butyl rubber sealant and encased in quick setting, non-shrink concrete followed by encasement with concrete. The encasement shall be centered on the joint, have a minimum thickness of six inches, and have a minimum length equal to the pipe diameter but not less than twelve inches. Methods for sealing open joints other than that described above shall be submitted to the Engineer for approval.
8. Backfill point repair in accordance with standard details and specifications.

**Backfilling:** The bedding, haunching and backfilling for pipe installation shall be as shown on the Drawings and as specified in Section 20 of the Water and Sewer Specifications except as modified in these Special Provisions.

**Pipe Bedding:** The Contractor shall furnish, place, compact and transport course aggregate gradation CA-7 or CA-11 for pipe bedding to a minimum depth of 4" below the bell of the pipe and 12" above the bell of the pipe. Pipe bedding under the replacement pipe section shall be compacted to prevent settlement and provide support.

**Excavated Material Backfill:** Backfill trenches with excavated material from trenches, unless granular material backfill is required as specified below. Excavated material shall consist of loam, clay or other materials, which, in judgment of Engineer, are suitable for

2019 SEWER REHABILITATION PROGRAM  
VILLAGE OF VILLA PARK

backfilling. Unsuitable backfill materials are not acceptable. Extend backfill from surface of cover material to ground surface, making allowance for surface restoration.

**Granular Material Backfill.** This work shall conform to Section 208 of the "Standard Specifications", and shall consist of furnishing, placing, compacting and transporting course aggregate gradation CA-6 for backfilling material for all trenches made beneath or within three feet (3') of the roadway or driveways. This item also includes the disposal of the surplus excavated material which is replaced by trench backfill. Such disposal shall be made in accordance with Article 202.03 of the "Standard Specifications".

The Contractor shall maintain trenches flush with existing surfaces until permanent patches are installed or site restoration is completed. No additional compensation will be provided to the Contractor for trench maintenance.

For all other areas not adjacent to pavement, excavated earth free from organic materials shall be used. Costs associated with earthen backfill shall be considered incidental to each Point Repair.

The Contractor shall also place granular material backfill within influence zone under new or existing roads, sidewalks, paved surface, or foundations and footings. Extend backfill from surface of cover material to top of existing pavement structure to allow backfill to function as temporary aggregate roadway. The Contractor shall replace backfill displaced by traffic movement as necessary until temporary bituminous pavement or permanent pavement is installed at no additional cost to the Village.

**Placing Backfill:** The Contractor shall not use frozen material for backfill or place backfill on frozen sub-grade. Care shall be taken to not exert undue stresses on new piping or existing utilities when dumping, spreading, and/or compacting backfill materials. Hand spreading and hand tamping may be required to adequately protect new pipe and existing utilities.

Where pipes leave structures, protect by backfilling pipe influence zone down to undisturbed soil as specified above for support of underground structure. Do not backfill structures until new concrete has properly cured.

**Compaction of Backfill.**

The trench backfill shall be compacted only by Method 1 as defined in Article 550.07 of the Standard Specifications.

The standard test to define maximum densities of all compaction work shall be ASTM D-1557. All densities shall be expressed as a percentage of the maximum density obtained in the laboratory by the ASTM D-1557 standard procedure. Each layer shall be compacted by mechanical means to 95 percent of the maximum dry density.

2019 SEWER REHABILITATION PROGRAM  
VILLAGE OF VILLA PARK

The Contractor shall start trench compaction at the point of lowest elevation of trench and work along the complete length of the trench. Backfill shall be placed around the pipe immediately after installation and inspection unless delay is approved by the Engineer.

The select granular backfill material shall be placed and compacted in 12-inch maximum layers of the specified materials as shown on the Drawings and installed from the top of bedding to the existing finished grade. Care shall be taken during compaction to prevent disturbance or injury of the pipe and other utilities.

Surface restoration, protection of overhead wires and utility poles, bracing of utility poles, traffic control, and all other work associated with completing the point repair shall be considered incidental to this cost item.

**Basis of Payment.** This work shall be paid at the Contract Unit Price per Lump Sum for each individual POINT REPAIR of the number specified.

Additional point repairs identified during the project shall be paid at the Contract Unit Price for Lump Sum for Each EMERGENCY POINT REPAIR, 8" DIAMETER, UP To 10' IN LENGTH, and of the depth specified.

If additional pipe required deviates by five feet or less from those lengths listed on the Plan Sheets, no additional compensation shall be made. Additional compensation may be approved by the Engineer for installation of pipe lengths in excess of five additional feet. Cost for additional pipe lengths shall be paid at the Contract Unit Price per Linear Foot for ADDITIONAL 8" SANITARY SEWER, ADDITIONAL 6" SANITARY LATERAL, or ADDITIONAL SERVICE CONNECTION REPAIR (WITHIN TRENCH).

**ITEM #24: NEW LATERAL SERVICE**

**Description.** Where indicated on the drawings, the Contractor shall find the existing lateral service in the parkway, then excavate and drill a new 6" lateral service into the existing sanitary manhole 7-017. The Contractor will grout and seal the connection at the manhole. The Contractor will then install a new cleanout in the parkway at the connection between the existing and new lateral services. A low angle bend shall be placed downstream of the new cleanout and be connected to the proposed lateral service. The existing 6" lateral service will be abandoned downstream of the proposed cleanout.

The price shall include the plugging of this existing service. The plug shall be constructed of either concrete blocks or common bricks set in mortar beds. The minimum thickness of the plugs inside the pipe to be abandoned shall be 24 inches. As an alternative to brick and mortar, the Contractor may submit data sheets for 6" mechanical wing plug (topped with mortar).

The Contractor shall coordinate with the homeowner of 118 East Monroe Street. All damage to lawns shall be restored with topsoil and sod as needed. All lawn restoration

**2019 SEWER REHABILITATION PROGRAM  
VILLAGE OF VILLA PARK**

shall be incidental. To minimize damage to lawns, Contractor shall utilize Duramats, rubber-tired vehicles or other means to buffer equipment traveling across private property.

Any damage, not related to the work described herein, to the private property caused by the Contractor's operations shall be resolved at his own expense.

The Village will be responsible for obtaining a Work Rights Agreement authorizing the Contractor's personnel to enter property located at 118 East Monroe Street.

Potholing existing utilities within the parkway as needed, and the restoration work including sidewalk replacement, topsoil and sod will be incidental of the price of this item.

The lateral service pipe material shall be HDPE, ASTM 3035, with a minimum DR of 26.

**Basis of Payment.** This work shall be paid at the Contract Unit Price per Lump Sum for NEW LATERAL SERVICE.

**ITEM #25: REPLACE COVER**

**Description.** Where indicated on the manhole rehabilitation schedule, the existing manhole cover shall be replaced with a new cover by the Contractor.

The new cover shall be in accordance with the general special provision FRAMES AND COVERS herein above. The sanitary manhole cover shall be self-sealing solid lid with watertight gasket and concealed pick hole. The Contractor is required to measure each cover that needs replacing to ensure proper fit.

**Basis of Payment.** This work will be paid for at the Contract Unit Price per Each for REPLACE COVER.

**ITEM #26: REPLACE FRAME AND COVER (UNPAVED)**

**Description.** Where indicated on the manhole rehabilitation schedule, the existing manhole frame and cover located in an unpaved area shall be replaced with a new frame and cover by the Contractor. Also included in the cost of this item is the replacement of the adjustment and installation of an external chimney seal as described in the provision SEAL AND ADJUST MANHOLE FRAME (UNPAVED).

The new frame and lid shall be in accordance with the general special provision FRAMES AND COVERS herein above. The Contractor is required to measure each cover and frame that needs replacing to ensure proper fit.

**Basis of Payment.** This work will be paid for at the Contract Unit Price per Each for REPLACE FRAME AND COVER (UNPAVED).

**ITEMS #27 & #28: SEAL AND ADJUST MANHOLE FRAME (UNPAVED) OR UNCOVER AND RAISE BURIED MANHOLE (UNPAVED)**

**Description.** For all frame adjustment work including replacements, adjustments, realignments and raises; the manhole adjustment rings shall be removed, replaced and sealed per the following specification. The Contractor may not reuse existing concrete rings during frame adjustment work. Frames that are indicated for adjustment and not replacement shall be removed, cleaned and sealed in accordance with the following specification. External chimney seals shall be included in this work.

**Construction requirements.** The Contractor shall remove existing frame and cover, remove all gasket material between the cone, adjustment rings and frame, and shall wire brush clean all exposed surfaces. Existing manhole frames and covers in good condition will be cleaned and reinstalled unless specified elsewhere for replacement. The Contractor shall replace all adjustment rings with new precast concrete rings.

Each structure shall be fitted with a minimum of one adjusting ring and a maximum of two adjusting rings. The topmost adjusting ring on each structure shall be rubber. The second adjusting ring on each structure, if needed, shall be precast concrete with steel reinforcement. The total height of all adjusting rings on a single structure shall be a minimum of 2 inches and a maximum of 12 inches.

The mating faces of adjusting rings shall be smooth, parallel, and free of cracks, chips, spalling, or casting irregularities.

EZ-STIK or an approved equal butyl mastic sealant shall be used when rejoining the manhole frame to the precast adjustments to provide a watertight structure. The sealing compound shall be produced from blends of refined hydrocarbon resins and plasticizing compounds reinforced with inert mineral filler, and shall contain no solvents, irritating fumes, or obnoxious odors. The compound shall not depend on oxidizing, evaporation, or chemical action for its adhesive or cohesive strength. It shall be supplied in extruded rope form of suitable cross section and in such sizes to seal the joint space. The Contractor shall use two (2) complete ropes at each joint.

After all other adjustment work has been completed, the interior surfaces of the adjustment, from the bottom of the frame to the top of the cone section, shall have a cement mortar finish applied which is then troweled and brushed to a smooth finish.

External chimney seals are to be installed for all frame adjustment work requiring excavation including adjustments, replacements, realignments and raises unless indicated otherwise by the Engineer. Acceptable external chimney seals are Infi-Shield or an approved equal. The Infi-Shield Uni-Band seal sealing system shall be installed according to the manufacturer's recommendations. This external sealing system shall prevent leakage of water into the manhole through the frame joint adjustment area. Frame seals shall remain flexible throughout a 50 year design life, allowing repeated vertical movement of the frame of not less than 2 inches and/or repeated horizontal movement of

2019 SEWER REHABILITATION PROGRAM  
VILLAGE OF VILLA PARK

not less than one half 1/2 inch. The seal shall be a continuous seamless band made of high quality EPDM (Ethylene Propylene Diene Monomer) rubber with a minimum thickness of 65 mils. There shall be a preformed "L" shaped corner molded into the top of the seal. The top section and the side section will extend from the "L" shaped corner at a generally 90-degree angle to each other, wherein the seal is pre-formed in substantially the same shape as when attached to the manhole structure. The thickness of the "L" shaped corner extending 1" into the top section and 1" down the side section is increased and may be at least twice the thickness of the top section reinforcing the seal at this particular area. There shall be a 2" to 3" wide strip of butyl mastic attached to the underside of top section of the seal. There shall be a 2" wide strip of butyl mastic attached to the inside of the side section at the bottom of the seal. The mastic shall be non-hardening butyl rubber sealant, with a minimum thickness of 1/8", and shall seal to the cone/top of the manhole section and over the flange of the casting frame. An aerosol primer shall be used to enhance the bond strength of the seal to the structure.

The Contractor shall excavate around the frame to a depth of at least 12 inches below the top of the cone section to allow for proper installation. The top section of the seal shall extend 3" attaching to the casting base/flange with the side section covering over the entire grade adjustment ring area and onto the cone section a minimum of 2". Install external manhole chimney seal as shown on the detail, with extensions where needed to cover the entire chimney area, in accordance with the manufacturer's instructions. External chimney seals installed shall not be buried until inspected by the Engineer.

This item shall include all work necessary for the complete adjustment and sealing of each manhole frame as specified in these provisions including measurement, procurement, installation, replacement, external chimney seals, adjustment rings and surface restoration on an unpaved area.

**Basis of Payment.** This work will be paid for the Contract Unit Price per Each for SEAL AND ADJUST MANHOLE FRAME (UNPAVED) or UNCOVER AND RAISE BURIED MANHOLE (UNPAVED).

**ITEM #29: INTERNAL CHIMNEY SEAL**

**Description.** Prior to installation of the internal chimney seal the adjustment shall be rehabilitated if it has not been replaced. The Contractor shall wire brush all loose material and remove any broken portions of the adjustment and then fill the voids with a quick setting fiber reinforced calcium aluminate corrosion resistant cement mortar grout. At each point of active leakage, injection grout such as Avanti AV-202 (for severe active infiltration) or Strong-Plug (for active infiltration) shall be used as appropriate. The adjustment is then to be patched prior to installation of wall coating or internal chimney seal. The Internal Chimney Seal shall be Raven581 or approved equal.

For surface preparation, surfaces should be thoroughly clean and dry. Concrete and mortar must be cured at least 7 days and no frost or wet conditions can be present during

2019 SEWER REHABILITATION PROGRAM  
VILLAGE OF VILLA PARK

installation. Remove all loose mortar and foreign material. Surface must be free of laitance, concrete dust, dirt, form release agents, moisture curing membranes, loose cement and hardeners. Fill bug holes, air pockets and other voids with Steel-Seam FT910. After ensuring that all surfaces are clean the chimney seal coating material shall be applied evenly by spraying over the entire chimney seal area including the frame joint area and the vertical riser of the manhole cone including all extensions to the chimney area.

Surface preparation, primer and internal chimney seal application (including recommended thickness) should be made in accordance with the manufacturer's recommendations and will take precedence over the specifications hereinabove.

The final internal chimney seal shall pass visual inspection and be completely free of pinholes or voids.

**Basis of Payment.** This work will be paid for the Contract Unit Price per Each for INTERNAL CHIMNEY SEAL.

**ITEMS #30 TO #32: CURTAIN GROUT MANHOLE, GROUT WALL JOINTS, AND GROUT BOTTOM 18"**

**Description.** This work shall govern all work, materials and testing required for chemical pressure grouting of manhole defects. Manholes or sections of manholes with leaks are shown on the Manhole Rehabilitation Schedule. Manhole structure grouting includes the sealing or plugging of the manhole base, walls, corbel/cone and chimney using chemical grout sealants to eliminate leakage. Chemical grout shall be injected into the soil surrounding the manhole as needed for complete sealing resulting in a grout curtain.

**Curtain Grout Manhole.** The Contractor shall furnish all labor, supervision, materials, equipment and testing if required for the completion of chemical grout sealing of manhole defects in accordance with the Contract Documents. Manhole grouting shall not be performed until sealing of manhole frame and grade adjustments is complete.

1. **Equipment:** The basic equipment shall consist of chemical pumps, chemical containers, injection packers, hoses, valves, and all necessary equipment and tools required to seal manholes by chemical pressure grouting. The chemical injection pumps shall be equipped with pressure meters that will provide for monitoring pressure during the injection of the chemical sealants. When necessary, liquid bypass lines equipped with pressure-regulating bypass valves will be incorporated into the pumping station.
2. **Chemical Sealing Materials:** The chemical grout shall be Avanti AV-100 or approved equal which has a documented record of satisfactory performance in sewer usage. All grouting materials shall be delivered to the job site in the original, labeled, and unopened containers. The Contractor shall submit with his bid, the

2019 SEWER REHABILITATION PROGRAM  
VILLAGE OF VILLA PARK

brand name manufacturer of the chemical grout(s) he intends to use. The chemical grout(s) selected by the Contractor is subject to approval of the Engineer.

3. The low viscosity, gel strengthening agent (copolymer latex) Avanti AV-257 ICOSSET or approved equal shall be used when Avanti AV-100 is applied to provide the cured material with improved hydrostatic pressure resistance, better low-temperature plasticity, and improved adhesion.
4. Mixing and handling of chemical grout, which may be toxic under certain conditions, shall be in accordance with the recommendations of the manufacturer and in such manner to minimize hazard to personnel. It is the responsibility of the Contractor to provide appropriate protective measures to ensure that chemicals or gels are handled by authorized personnel in the proper manner. All equipment shall be subjected to the approval of the Engineer. Only personnel thoroughly familiar with the handling of the grout material and additives shall perform the grouting operations.
5. Preliminary repairs: All cracked or deteriorated material shall be removed from the manhole and the Contractor shall cut and trim all roots within the manhole. The Contractor shall seal all unsealed lifting holes, unsealed step holes, pre-cast manhole section joints, and voids larger than approximately 1/2" in thickness with a waterproof quick-setting mortar, Strong Seal QSR; Quadex Hyperform or an approved equal in accordance with the manufacturer's specifications.
6. Drilling and Injection: Injection holes shall be drilled through the manhole at 120 degree angles from each other at the same plane of elevation. Rows shall be separated no more than three vertical feet, and the holes shall be staggered with the holes in the rows above and below. Provide additional injection holes near observed defects, bench and trough and at pipe seals. At all visible leaks and areas with evidence of leaks within the manhole structure, a hole shall be carefully drilled from within the manhole and shall extend through the entire manhole wall. A minimum of 6 injection holes shall be provided in the walls/cone and three injection holes at each pipe seal and at the bench/trough.
7. Manholes shall be grouted completely from the pipe invert to the top of the corbel or bottom of flat top. Grout shall be injected through the holes under pressure with a suitable probe. Grout ports or sealant injection devices shall be placed in these previously drilled holes in such a way as to provide a watertight seal between the holes and the injection device. A hose, or hoses, shall be attached to the injection device from an injection pump. Grouting from the ground surface shall not be allowed. Grout travel shall be verified by observation of grout to defects or adjacent injection holes. Provide additional injection holes, if necessary to ensure grout travel. Care shall be taken during the pumping operation to ensure that excessive pressures do not develop and cause damage to the manhole structure or surrounding surface features. Grout shall be injected through the lowest holes first. The procedure shall be completed until the manhole is externally sealed with grout, resulting in a chemical grout curtain.
8. Sealing after grouting: Upon completion of the injection, all chemical grout material shall be removed from interior surfaces of the manhole. After grouting is

2019 SEWER REHABILITATION PROGRAM  
VILLAGE OF VILLA PARK

completed, the grout ports shall be removed and the remaining holes shall be cleaned with a drill and filled with quick-setting hydraulic mortar and troweled flush with the surface of the manhole walls or other surfaces. The mortar used shall be a non-shrink patching mortar such as Strong Seal QSR; Quadex Hyperform or an approved equal. In addition to filling the holes the interior surface of the manhole shall be patched with a ½" thick quick setting mortar such as Strong Seal QSR; Quadex Hyperform or an approved equal. This coating shall cover at least 6" either side of the joint sealed or where injection holes were drilled.

**Grout Wall Joints.** The procedures for Grout Wall Joint shall be the same as listed above for a complete curtain grout manhole, but shall be limited to wall joints and/or areas with evidence of infiltration for each manhole indicated on the manhole rehabilitation schedule. Holes shall be carefully drilled from within the manhole and shall extend through the entire manhole wall. In cases where there are multiple leaks around the circumference of the manhole, fewer holes may be drilled, providing all leakage is stopped from these holes. Grout ports or sealant injection devices shall be placed in these previously drilled holes in such a way as to provide a watertight seal between the holes and the injection device. A hose, or hoses, shall be attached to the injection device from an injection pump. Grout travel shall be verified by observation of grout to defects or adjacent injection holes. Provide additional injection holes, if necessary to ensure grout travel.

Sealing after grouting wall joints shall be the same as above and shall include patching with a ½" thick quick setting mortar such as Strong Seal QSR; Quadex Hyperform or an approved equal and shall cover at least 6" either side of the joint sealed or where injection holes were drilled.

**Grout Bottom 18".** The procedures for Grout Bottom, 18" shall be the same as indicated above, but shall be limited to the bottom portion of the manhole. Pipe seal grouting shall include all pipe seals in the specified manhole and grouting of the bench/trough, wall/bench joint and walls to the maximum height of 18" from the crown of the pipe. Provide additional injection holes near observed defects, bench and trough and at pipe seals. At all visible leaks, a hole shall be carefully drilled from within the manhole and shall extend through the entire manhole wall. A minimum of three injection holes at each pipe seal and at the bench/trough shall be required.

Sealing after grouting manhole bottoms shall be the same as above and shall include patching with a ½" thick quick setting mortar such as Strong Seal QSR; Quadex Hyperform or an approved equal and shall cover at least 6" either side of each location sealed or where injection holes were drilled.

**Final Acceptance.** After the specified sealing work has been completed, the manholes shall be visually inspected by the Contractor (as required) in the presence of the Engineer and found to be acceptable. All rehabilitated manholes shall also be re-inspected for leaks two months after completion and resealed, if necessary, at no additional cost to the Village.

2019 SEWER REHABILITATION PROGRAM  
VILLAGE OF VILLA PARK

**Basis of Payment.** This work will be paid for at the Contract Unit Price per Each for CURTAIN GROUT MANHOLE or GROUT BOTTOM 18". Payment shall be based on the Contract Unit Price per Each joint for GROUT WALL JOINTS.

**ITEM #33: CEMENTITIOUS MANHOLE SEALING**

**Description.** Manhole sealing shall consist of all necessary measures to internally seal the manhole including cementitious wall coating, external or internal grouting, and reconstruction of bench/trough and shall establish structural integrity for the manhole and shall eliminate inflow and infiltration.

This work shall provide for a monolithic fiber-reinforced calcium aluminate structural cementitious spray liner applied in two ½ inch lifts intended to seal the entire manhole structure. The spray liner shall be a complete manhole reconstruction that stops inflow and infiltration, providing a leak free structure, restoring structural integrity and providing protection against corrosion.

This specification shall govern all work, materials, and equipment required for manhole rehabilitation for the purpose of eliminating infiltration, exfiltration, providing corrosion protection, repair of voids, and restoration of the structural integrity of the manhole as a result of applying a monolithic fiber-reinforced structural cementitious liner to the adjustment, cone, wall and bench surfaces of brick, block, pre-cast or poured concrete, or other masonry construction material.

Described are procedures for cleaning, preparation, application and testing. The applicator, approved and trained by the manufacturer, shall furnish all labor, equipment and materials for applying a cementitious mix to form two coats of a structural monolithic liner, with machinery specially designed for the application. All aspects of the installations shall be in accordance with the manufacturer's recommendation and per the following specifications which includes:

1. Remove loose and unsound material:

Loose and protruding brick, mortar and concrete shall be removed using a mason's hammer and chisel and/or a scraper. Any loose debris on the benches, inverts or walls of the manhole shall be removed by means of a scraper and vacuum machine or other approved method as long as it is taken from the manhole and not caused to go into the sewer. Any damaged manhole steps shall be removed prior to cleaning the interior of the manhole. Place covers over invert to prevent extraneous material from entering the sewer lines before cleaning.

2. Clean area to be sprayed:

The Contractor shall clean the interior surfaces of manhole removing all debris, dirt, oil, grease, remains of old coating materials, and any other extraneous materials. The

**2019 SEWER REHABILITATION PROGRAM  
VILLAGE OF VILLA PARK**

Contractor shall then pressure wash (minimum 3,000 psi) the manhole walls to remove loose mortar, concrete, roots, and debris. Heavy grease build-up or unusual conditions may require hydro-blasting or chemical cleaning. Loose and protruding brick, mortar and concrete shall be removed using a mason’s hammer and chisel and or scraper.

**3. Eliminate infiltration:**

The following are approved for patching material: Strong Seal QSR; Quadex Hyperform; or approved equal. This quick setting fiber reinforced calcium aluminate corrosion resistant cementitious material, shall be used as a patching material and is to be mixed and applied according to manufacturer’s recommendations and shall have the following minimum requirements:

Compressive Strength:	ASTM C109	>1800 psi, 1 hr >2600 psi, 24 hrs
Bond:	ASTM C882	>1600 psi, 28 days
Calcium Aluminate Cement:		Sulfate resistant
Applied Density:		105 lbs/ft3 ± 5
Shrinkage:	ASTM C490	0% at 90% R. H.
Placement Time:		5 to 10 minutes
Set Time:		15 to 30 minutes

Approved materials to stop visible infiltration are the following: Strong-Plug; Quadex Quad-Plug; or approved equal. This rapid setting cementitious product specifically formulated for leak control, shall be used to stop minor water infiltration and shall be mixed and applied according to manufacturer’s recommendations and shall have the following minimum requirements:

Compressive Strength:	ASTM C109	>1000 psi, 1 hr >2500 psi, 24 hrs
Sulfate Resistance:	ASTM C267	No wt loss, 15 cycles at 2000 ppm
Freeze/Thaw:	ASTM C666	Method A 100 cycles
Pull Out Strength:	ASTM C234	14,000 lbs
Set Time:		<1. 0 minute

Approved materials to stop severe active infiltration are the following: Hydrostop-Flex 40/500; Avanti AV-100; Deneef Denepox 40; or approved equal. Grouting installation shall conform to ASTM F2414-04. Grouting shall be performed anywhere where active infiltration cannot be stopped with the cementitious grout.

4. Repair and fill voids:

The Contractor shall fill any large voids using one of the approved patching materials. Active Leaks shall be stopped using quick-setting, specially formulated mixes, according to manufacturer's recommendations. Some leaks may require weep holes to localize infiltration during the application. After application the weep holes shall be plugged with quick setting material. After repairing and filling voids and preparations are complete, remove all loose material and wash again. Any bench or invert repairs shall be made at this time using the quick-setting patching mix.

5. Cleanup bench troughs/inverts:

Bench troughs/Inverts shall be cleanup with a high pressure washer.

6. Spraying the cementitious monolithic liner:

Liner Material shall be Strong-Seal MS2-C or an approved equal and shall be made with calcium aluminate cement and shall be used according to manufacturer's recommendations in applications where there is evidence of mild sulfide conditions (substrate surface of pH 2.0 or higher). The cementitious liner shall be used to form a structural monolithic liner covering all interior manhole surfaces and shall have the following minimum requirements:

Compressive Strength:	ASTM C109 at 28 days	>9000 psi
Tensile Strength:	ASTM C109 at 28 days	>800 psi
Flexural Strength:	ASTM C109 at 28 days	>1200 psi
Shrinkage @90% R. H.:	ASTM C109 at 28 days	0%
Bond:	ASTM C109 at 28 days	>2000 psi
Density, When Applied:		134 ± 5lbs/ft3
Freeze/Thaw:	ASTM C109 at 28 days	300 cycles no visual damage

During application the surface shall be clean and free of all foreign material and shall be damp without noticeable free water droplets or running water, but totally saturated just prior to application of material. Materials shall be spray applied in two lifts, at least 24 hours apart. Minimum total thickness for each pass shall not be less than 1/2 inch and shall be from the bottom of the frame to the invert of the manhole. The surface shall then be troweled to a relatively smooth finish being careful not to over trowel. A brush finish shall be applied to the trowel-finished surface.

After the walls are coated, the invert covers shall be removed and the bench sprayed with excess materials applied in such a manner that a gradual slope is produced from the walls to the invert with the thickness at the invert to be no less than 1/2 inch. The wall/bench intersection shall be rounded to a uniform radius the full circumference of the intersection. Trough area shall be coated as required to seal all cracks and to provide a smooth surface.

2019 SEWER REHABILITATION PROGRAM  
VILLAGE OF VILLA PARK

The material shall have minimum of four (4) hours cure time before being subjected to active flow. Ambient conditions in the manhole are adequate for curing as long as the manhole is covered. Traffic shall not be allowed over manholes for 12 hours after reconstruction is complete. Caution shall be taken to minimize exposure of applied product to sunlight, quick surface drying and air movement. At no time should the finished product be exposed to sunlight or air movement for longer than 15 minutes before replacing the cover. In extremely hot and arid climates, the manhole should be shaded while reconstruction is in process.

No application shall be made if ambient temperature is below 40 degrees Fahrenheit. No application shall be made to frozen surfaces or if freezing is expected to occur within the substrate within 24 hours after application. If the ambient temperatures are in excess of 95 degrees Fahrenheit, precautions shall be taken to keep the mix temperatures at time of application below 90 degrees Fahrenheit. Water temperature shall not exceed 80 degrees Fahrenheit. Chill with ice if necessary. Final acceptance shall be made upon successfully passing a vacuum test as specified hereinafter (at least 25% of manholes shall be tested). VACUUM TESTING will be paid for separately.

The price for this item shall also include plugging of any existing abandoned pipes where directed by the Engineer. The plugs shall be constructed of either concrete blocks or common bricks set in mortar beds. The minimum thickness of the plugs inside the pipe to be abandoned shall be 24 inches. As an alternative to brick and mortar, the Contractor may submit data sheets for mechanical wing plugs (topped with mortar) of the specified diameter for consideration to be used.

**Basis of Payment.** This item will be paid for at the Contract Unit Price per Vertical Foot for CEMENTITIOUS MANHOLE SEALING for the manhole diameter.

**ITEM #34: REPAIR BENCH AND TROUGH**

**Description.** Invert repair shall be performed on all inverts with visible damage or where infiltration is present or when vacuum testing is specified. After blocking the flow through the manhole and thoroughly cleaning the invert, a quick-setting patch material shall be applied in an expeditious manner. The material shall be troweled uniformly onto the damaged invert at a minimum thickness of ½ inch at the invert extending out onto the bench of the manhole sufficiently to tie into the structural monolithic liner to be spray applied. The finished invert shall be smooth and free of ridges. The flow may be re-established in the manhole within 30 minutes after placement of the material.

The trough shall then be coated with a cementitious product such as Strong Seal MS2-C or equal in the manner specified in CEMENTITIOUS MANHOLE SEALING.

**Basis of Payment.** This work will be paid for at the Contract Unit Price per Each for REPAIR BENCH AND TROUGH.

**ITEM #35: REPLACE BENCH AND TROUGH**

**Description.** This work item shall consist of the complete removal and reconstruction of the entire manhole bench and trough. The existing deteriorated bench and trough area shall be completely removed to a minimum depth of 12 inches below the existing invert. Care must be taken to avoid damaging other areas of the manhole structure. Loose and broken concrete shall be routinely removed from the manhole to eliminate the possibility of pieces entering the sewer lines. After removal of loose and broken concrete, CA-7, (¾-inch - 1-inch) washed limestone with no fines shall be installed to a depth of (8) eight inches as a base for the new bench and trough to be formed using Portland Cement Concrete, (PCC). Sanitary sewer service shall be maintained during bench and trough replacement. Minimum bench and trough thickness shall be 4 inches in depth.

All inverts shall be formed to the diameter of the incoming and outgoing pipe diameter up to the pipe centerline and vertical beyond that point. The invert shall be formed to a depth of one-half to two-thirds the pipe diameter. Inverts shall be formed with a PCC mortar material and steel-trowel to produce a dense, smooth finish and shape to form a "U"-shaped channel connecting the pipelines. The new invert shall provide smooth transitions for pipes of different sizes, different elevations, and/or at different angles. The Contractor shall form benches to provide self-cleaning by sloping normally two (2) inches from manhole wall to edge of "U" channel with a smooth finish. The trough shall be troweled so that the wetted surface is smooth. The invert of the trough shall form a continuous conduit with the sewer pipe entering and leaving the manhole provided that the pipe was originally constructed or intended to be constructed in this manner. Care shall be taken to prevent the degradation of freshly poured benches and troughs.

The bench and trough shall be furnished in such a manner so that a watertight seal exists between the manhole walls, pipe, and bench/trough area. The finished bench and trough shall be cleaned of silt, debris or foreign matter of any kind.

**Basis of Payment.** This work will be paid for at the Contract Unit Price per Each for REPLACE BENCH AND TROUGH.

**ITEM #36: VACUUM TESTING**

**Description.** This specification shall govern the vacuum testing of sanitary sewer manholes and structures and shall be used as a method of determining acceptability by the Engineer, in accepting maintenance or installation of a sanitary sewer manhole or structure. Vacuum testing shall be according to ASTM C1244, except as specified otherwise herein.

At least twenty-five percent (25%) of the total number of sanitary sewer manholes receiving cementitious coating shall be vacuum tested as specified herein. Manholes to be tested shall be selected by the Engineer at the time of testing. No advance notice will be provided to the Contractor as to which manholes will be tested. If more than ten percent

**2019 SEWER REHABILITATION PROGRAM  
VILLAGE OF VILLA PARK**

(10%) of the manholes tested fail the initial test, an additional twenty-five percent (25%) of the total manholes shall be tested at no additional charge. This process shall continue until a series of manholes (25% of the total) successfully test with no more than 10% initial failure or until all manholes have been tested. Additional vacuum testing required after failing the initial testing will be considered incidental to the contract and will not be paid for separately.

Manholes shall be tested after rehabilitation and when all connections are in place. The vacuum test shall include testing of the seal between the cast iron frame and the concrete cone, slab or grade rings.

When coating or lining is applied to the interior of the manhole, the vacuum test must not be performed until the coating or lining has been cured according to the manufacturer's recommendations.

Procedure for testing shall be as follows:

1. Temporarily plug all pipes entering the manhole. Each plug must be installed at a location beyond the manhole/pipe gasket (i. e. outside the manhole wall), and shall be braced to prevent the plug or pipe from being drawn into the manhole.
2. The test head shall be placed inside the rim of the cast iron frame at the top of the manhole and inflated.
3. A vacuum of at least ten inches of mercury (10" Hg) shall be drawn on the manhole. Shut the valve on the vacuum line to the manhole and shut off the pump or disconnect the vacuum line from the pump.
4. The pressure gauge shall be liquid filled, having a 3. 5-inch diameter face with a reading from zero to thirty inches of mercury.

The manhole shall be considered to pass the vacuum test if the vacuum reading does not drop more than 1" Hg (i. e. from 10" Hg to 9" Hg) during the following minimum test times for various manhole diameters.

	<b>Manhole Diameter (inches)</b>								
	<b>30</b>	<b>33</b>	<b>36</b>	<b>42</b>	<b>48</b>	<b>54</b>	<b>60</b>	<b>66</b>	<b>72</b>
<b>Depth (ft. )</b>	<b>Test Time (Seconds)</b>								
<b>8</b>	11	12	14	17	20	23	26	29	33
<b>10</b>	14	15	18	21	25	29	33	36	41
<b>12</b>	17	18	21	25	30	35	39	43	49
<b>14</b>	20	21	25	30	35	41	46	51	57
<b>16</b>	22	24	29	34	40	46	52	58	67

**Basis of Payment.** This work will be paid for at the Contract Unit Price per Each for VACUUM TESTING.

**ITEM #37: WATER USAGE DEDUCTION**

**Description.** This item are provided as a part of this contract for the purpose of documenting the quantity of water obtained from the Village by the Contractor.

If the Contractor elects to obtain water from the Village, the Contractor shall comply with the Special Provision USE OF FIRE HYDRANTS. The quantity of water obtained from the Village by the Contractor shall be deducted from the contract as WATER USAGE DEDUCTION, and shall be credited to the contract as WATER USAGE CREDIT.

The WATER USAGE DEDUCTION ITEM for this contract has been established with a unit of measurement in thousands of gallons (TGAL), a quantity of one hundred (100.00), and a contract unit price of a deduction of eight dollars and eighty five cents (\$8.85), for a total WATER USAGE DEDUCTION contract price of a deduction of eight hundred eighty five dollars and no cents (\$885.00). Bidder, in submitting a bid, accepts the quantity, contract unit price, and total contract price of the WATER USAGE DEDUCTION ITEM.

**Method of Measurement.** Water usage will be measured as the actual quantity of water obtained from the Village by the Contractor, which quantity shall be rounded up to the nearest 1,000 gallons.

**Basis of Payment.** The water usage deduction will be deducted at the contract unit price per Thousand Gallons (TGAL) for WATER USAGE DEDUCTION. The quantity deducted as WATER USAGE DEDUCTION will be equal to the quantity paid for as WATER USAGE CREDIT.

**ITEM #38: WATER USAGE CREDIT**

**Description.** This item are provided as a part of this contract for the purpose of documenting the quantity of water obtained from the Village by the Contractor.

If the Contractor elects to obtain water from the Village, the Contractor shall comply with the Special Provision USE OF FIRE HYDRANTS. The quantity of water obtained from the Village by the Contractor shall be deducted from the contract as WATER USAGE DEDUCTION, and shall be credited to the contract as WATER USAGE CREDIT.

The WATER USAGE CREDIT ITEM for this contract has been established with a unit of measurement in thousands of gallons (TGAL), a quantity of one hundred (100.00), and a contract unit price of eight dollars and eighty five cents (\$8.85), for a total WATER USAGE CREDIT contract price of eight hundred eighty five dollars and no cents (\$885.00). Bidder, in submitting a bid, accepts the quantity, contract unit price, and total contract price of the WATER USAGE CREDIT ITEM.

**2019 SEWER REHABILITATION PROGRAM  
VILLAGE OF VILLA PARK**

**Method of Measurement.** Water usage will be measured as the actual quantity of water obtained from the Village by the Contractor, which quantity shall be rounded up to the nearest 1,000 gallons.

**Basis of Payment.** The water usage credit will be paid for at the contract unit price per Thousand Gallons (TGAL) for WATER USAGE CREDIT. The quantity paid for as WATER USAGE CREDIT will be equal to the quantity deducted as WATER USAGE DEDUCTION.

**ITEM #39: PROJECT MANAGEMENT**

**Description.** Project Management shall include all supervision work associated with performing the point repair or new lateral service at a given residence. This item is only applicable where work on private property is required or where private property will be used to access the repair location. A two (2) hour allotment will be allowed for each home. This work will include contacting the homeowner, meeting with the homeowner to discuss the access route, obtaining homeowner signature on project agreement, scheduling the work with the owner, and all other project management tasks associated with completing the spot repair or manhole installation. No additional compensation will be allowed for the management of the project.

**Basis of Payment.** This work will be paid for as two (2) Hours for each home where a manhole, mainline, or point repair is completed on private property at the Contract lump sum price for PROJECT MANAGEMENT. No additional compensation will be allowed.

**ITEM #40: TRAFFIC CONTROL AND PROTECTION**

**Description.** This work shall consist of the furnishing, installation, maintenance, relocation, and removal of work zone traffic control and protection. This work shall be in accordance with Section 701 of the Standard Specifications, the Supplemental Specifications, the "Illinois Manual of Uniform Traffic Control Devices", the Highway Standards and details contained in the Plans and Special Provisions, and the Special Provisions contained herein, except as modified herein.

The bid price for TRAFFIC CONTROL AND PROTECTION shall not exceed 5 percent of the total bid price. If the bid price for TRAFFIC CONTROL AND PROTECTION exceeds 5 percent of the total bid price, the Village may reject the Bid.

Special Attention is called to Article 107.09 of the Standard Specifications and the following Highway Standards, Details, Recurring Local Roads and Streets Special Provisions, and Special Provisions contained herein, relating to traffic control.

Highway standards: 701301, 701501, 701801, 701901.

**Details:**

- Traffic Control and Protection for Side Roads, Intersections, and Driveways (TC 10)

**Special provisions (Included in these Special Provisions):**

- Maintenance of Roadways
- Work Zone Traffic Control Surveillance (LRS 3)
- Flaggers in Work Zones (LRS 4)
- Sidewalk, Corner, or Crosswalk Closure (BDE)

Contractor shall contact the Village at least 72 hours in advance of beginning work. Construction operations shall be conducted in a manner such that streets shall be open to emergency traffic and accessible as required to local traffic. Advanced notice shall be provided to residents, police, fire, school districts, school bus companies, and trash haulers when access to any street will be temporarily closed or limited. The work shall be accomplished such that the streets shall be left open to local traffic at the end of each workday.

**Basis of Payment.** Traffic control and protection will be paid for at the contract Lump Sum price for TRAFFIC CONTROL AND PROTECTION.

**OWNER COPY**

**CONTRACT**

**OWNER COPY**

**CONTRACT**

**2019 SEWER REHABILITATION PROGRAM  
VILLAGE OF VILLA PARK**

**APPENDIX 1**

**SEWER LINING, GROUTING AND POINT REPAIR LOCATION MAP (EXHIBIT 0)**



**OWNER COPY**

**CONTRACT**

**2019 SEWER REHABILITATION PROGRAM  
VILLAGE OF VILLA PARK**

**APPENDIX 2**

**POINT REPAIR SCHEDULE  
POINT REPAIR, T-LINER AND LATERAL SERVICE TELEVISIONING REPORTS  
POINT REPAIR PHOTO REPORT  
PLAN AND PROFILE SHEETS (NO. 1 TO 5), AND DETAIL SHEET (NO. 6)**

**VILLAGE OF VILLA PARK  
2018 SEWER REHABILITATION PROGRAM**

**POINT REPAIR SCHEDULE**

No.	Location	Upstream Manhole	Downstream Manhole	Length (ft)	Pipe Diam. (in)	Material	Distance from Upstream MH (ft)	Length of P.R. (ft)	Estimated to Top of Pipe (ft)	Recommendations
1	838 South Euclid Avenue	6-018	6-017	337.9	8	VCP	133.6	8	5.8	8' in length; includes 1 active service.
2	935 South Summit Avenue	6-170	6-025	320.2	8	VCP	61.1	13	10.0	8' in length; includes 1 active service.
3	1011 South Summit Avenue	6-025	6-034	376.7	8	VCP	27.5	6	8.0	8' in length; no active service.
4	639 West Pleasant Avenue	3-090	3-091	425.6	8	VCP	198.7	8	8.5	8' in length; includes 2 active services.

**LATERAL SERVICE SCHEDULE**

No.	Location of existing lateral service	Upstream Manhole	Downstream Manhole	Length (ft)	Pipe Diam. (in)	Material	Distance from Upstream MH (ft)	Length of P.R. (ft)	Estimated to Top of Pipe (ft)	Recommendations
1	118 East Monroe Street	7-017	7-016	219.8	8	VCP	7.7	6	11.4	Installation of new lateral service with 20' drill approx.; Grout and seal new lateral service to MH 7-017

## T-LINING SCHEDULE

No.	Location of existing lateral service	Upstream Manhole	Downstream Manhole	Length (ft)	Pipe Diam. (in)	Material	Distance from Upstream MH (ft)	Length of T-liner(ft)	Clock	Recommendations
1	636 Pleasant Avenue	3-90	3-91	425.6	8	Lined	259.3	5	9	Contractor to determine if service is live prior to reinstatement

# Appendix A:

# TV Reports

**Tabular Report of PSR 6-018 X for Village of Villa Park**

Setup	6	Surveyor	Tony	Certificate #	U-906-1643	System Owner	
Drainage		Survey Customer	Village of Villa Park				
P/O #		Date	2016/07/14	Time	12:29	Street	rear easement euclid-grant
City	Villa Park	Further location details					
Up	6-018	Rim to invert		Grade to invert		Rim to grade	Ft
Down	6-017	Rim to invert		Grade to invert		Rim to grade	Ft
Use		Direction	Down	Flow control	Not Controlled	Media No	
Shape	Circular	Height	8	Width	8 ins	Preclean	J
Material	Vitrified Clay Pipe	Joint length		Total length	338.0	Date Cleaned	2016/07/14
Lining		Year laid		Year rehabilitated		Length Surveyed	338.0
Purpose	Routine Assessment	Cat		Weather	Dry	Pressure	
Additional info						Structural	O & M
Location						Miscellaneous	Hydraulic
Project						Constructional	
Northing						Work Order	
Easting						Elevation	
Coordinate System						GPS Accuracy	

Count	Video	CD Code	In1	In2	%	JntFr	To	ImRef	Remarks
0.0		ST Start of Survey							
0.0		AMH Manhole							6-018
0.0		MWL Water Level			5				
5.7		RBJ Roots Ball Joint			95	J	12	11	
5.9		TB Tap Break-in	6.000				01		
7.2		RFJ Roots Fine Joint				J	07	05	
17.7		TF Tap Factory	6.000				02		
29.1		TB Tap Break-in	6.000				09		
34.4		TFC Tap Factory Capped	6.000				02		
38.2		TFC Tap Factory Capped	6.000				09		
40.4		RFJ Roots Fine Joint				J	04		
43.6		RFJ Roots Fine Joint				J	04		
93.6		TB Tap Break-in	6.000				09		
94.3		TB Tap Break-in	6.000				02		
98.9		TFC Tap Factory Capped	6.000				02		
101.7		TFC Tap Factory Capped	6.000				09		
128.9		RFJ Roots Fine Joint				J	07	05	
133.6		TB Tap Break-in	6.000				03		
133.6		HVV Hole Void Visible					04		
133.6		FM Fracture Multiple					06	05	
136.8	S01	RFJ Roots Fine Joint				J	07	05	
143.0		TB Tap Break-in	6.000				10		
156.4		TFC Tap Factory Capped	6.000				02		
159.4		TFC Tap Factory Capped	6.000				09		
190.8		FC Fracture Circumferential					10	09	
190.8		TB Tap Break-in	6.000				09		
199.0		TFC Tap Factory Capped	6.000				02		
202.5		TFC Tap Factory Capped	6.000				09		
215.5		TB Tap Break-in	6.000				02		
234.1	F01	RFJ Roots Fine Joint				J	07	05	
250.7		RFJ Roots Fine Joint				J	04		

**Tabular Report of PSR 6-018 X for Village of Villa Park**

<b>Setup</b> 6	<b>Surveyor</b> Tony	<b>Certificate #</b> U-906-1643	<b>System Owner</b>
<b>Drainage</b>	<b>Survey Customer</b> Village of Villa Park		
<b>P/O #</b>	<b>Date</b> 2016/07/14	<b>Time</b> 12:29	<b>Street</b> rear easement euclid-grant
<b>City</b> Villa Park	<b>Further location details</b>		
<b>Up</b> 6-018	<b>Rim to invert</b>	<b>Grade to invert</b>	<b>Rim to grade</b> Ft
<b>Down</b> 6-017	<b>Rim to invert</b>	<b>Grade to invert</b>	<b>Rim to grade</b> Ft
<b>Use</b>	<b>Direction</b> Down	<b>Flow control</b> Not Controlled	<b>Media No</b>
<b>Shape</b> Circular	<b>Height</b> 8	<b>Width</b> 8	<b>ins</b> Preclean J
<b>Material</b> Vitrified Clay Pipe	<b>Joint length</b>	<b>Total length</b> 338.0	<b>Date Cleaned</b> 2016/07/14
<b>Lining</b>	<b>Year laid</b>	<b>Year rehabilitated</b>	<b>Length Surveyed</b> 338.0
<b>Purpose</b> Routine Assessment	<b>Cat</b>		<b>Weather</b> Dry
<b>Additional info</b>			<b>Pressure</b>
<b>Location</b> Easement/Right of Way			<b>Structural</b> O & M Constructional
<b>Project</b> Villa Park 2016			<b>Miscellaneous</b> Hydraulic
<b>Northing</b>			<b>Work Order</b>
<b>Coordinate System</b>			<b>Elevation</b>
<b>Count Video</b>			<b>GPS Accuracy</b>
<b>CD Code</b>	<b>In1</b>	<b>In2</b>	<b>% JntFr To ImRef</b> Remarks
257.7			TFC Tap Factory Capped 6.000 02
259.2			TFC Tap Factory Capped 6.000 10
264.0			TB Tap Break-in 6.000 02
264.0			RBC Roots Ball Connection 75 02
266.4	S02		RFJ Roots Fine Joint J 07 05
281.1			TB Tap Break-in 6.000 09
281.1			CC Crack Circumferential 10 04
320.4			TFC Tap Factory Capped 6.000 02
324.5			TFC Tap Factory Capped 6.000 09
331.6			TB Tap Break-in 6.000 02
337.9	F02		RFJ Roots Fine Joint J 07 05
337.9			AMH Manhole 6-017
338.0			FH End of Survey

338.0 Ft Total Length Surveyed

<b>Scores</b>	<b>Structural:</b> Pipe Rating 12	Pipe Ratings Index 3	Peak 9	Mean Pipe 0
	<b>O&amp;M:</b> Pipe Rating 46	Pipe Ratings Index 0.9	Peak 4	Mean Pipe 0.1

Tabular Report of PSR 6-170 X for Village of Villa Park

Setup	10	Surveyor Tony	Certificate # U-906-1643	System Owner
Drainage	Survey Customer Village of Villa Park			
P/O #	Date 2016/07/15	Time 10:15	Street rear easement grant-summit	
City	Villa Park	Further location details		
Up	6-170	Rim to invert	Grade to invert	Rim to grade Ft
Down	6-025	Rim to invert	Grade to invert	Rim to grade Ft
Use	Sanitary	Direction Down	Flow control Not Controlled	Media No
Shape	Circular	Height 8	Width 8 ins	Preclean J Date Cleaned 2016/07/15
Material	Vitrified Clay Pipe	Joint length	Total length 320.2	Length Surveyed 320.2
Lining		Year laid	Year rehabilitated	Weather Dry
Purpose	Routine Assessment	Cat		Pressure
Additional info			Structural	O & M
Location Easement/Right of Way			Miscellaneous	Hydraulic
Project Villa Park 2016			Constructional	
Northing			Work Order	
Coordinate System			Elevation	
			GPS Accuracy	

Count	Video	CD	Code	In1	In2	%	JntFr	To	ImRef	Remarks
0.0			ST Start of Survey							
0.0			AMH Manhole							6-170
0.0			MWL Water Level			5				
9.3			TB Tap Break-in	6.000				10		
28.4			CL Crack Longitudinal					12		
30.0			MMC Material change							VCP TO PVC
32.2			TF Tap Factory	6.000				03		
35.0			MMC Material change							PVC TO VCP
36.6			FM Fracture Multiple					06	04	
38.9		S01	RMJ Roots Medium Joint			5	J	07	05	
52.7			RBB Roots Ball Barrel			95		06	05	
54.9			TFC Tap Factory Capped	6.000				09		
58.2			TFC Tap Factory Capped	6.000				02		
58.2			TB Tap Break-in	6.000				09		
61.1			B Broken					12		
63.8			FL Fracture Longitudinal					12		
80.4		F01	RMJ Roots Medium Joint			5	J	07	05	
92.6			TB Tap Break-in	6.000				02		
112.3			TFC Tap Factory Capped	6.000				09		
115.2			TFC Tap Factory Capped	6.000				03		
115.2			DAGS Deposits Attached Grease			5		10	02	
122.1			MWLS Water Level Sag			20				
129.3			RMJ Roots Medium Joint			5	J	07	05	
132.5			FL Fracture Longitudinal					12		
132.5			RFJ Roots Fine Joint				J	07	05	
133.8			TF Tap Factory	6.000				10		
133.8			RBC Roots Ball Connection			55		10		
140.9			MWLS Water Level Sag			20				
152.6			TB Tap Break-in	6.000				02		
172.8			TFC Tap Factory Capped	6.000				09		
175.7			TFC Tap Factory Capped	6.000				02		

Tabular Report of PSR 6-170 X for Village of Villa Park

Setup	10	Surveyor Tony	Certificate # U-906-1643	System Owner						
Drainage		Survey Customer	Village of Villa Park							
P/O #		Date 2016/07/15	Time 10:15	Street rear easement grant-summit						
City	Villa Park	Further location details								
Up	6-170	Rim to invert	Grade to invert	Rim to grade Ft						
Down	6-025	Rim to invert	Grade to invert	Rim to grade Ft						
Use	Sanitary	Direction Down	Flow control Not Controlled	Media No						
Shape	Circular	Height 8	Width 8 ins	Preclean J Date Cleaned 2016/07/15						
Material	Vitrified Clay Pipe	Joint length	Total length 320.2	Length Surveyed 320.2						
Lining		Year laid	Year rehabilitated	Weather Dry						
Purpose	Routine Assessment	Cat		Pressure						
Additional info				Structural O & M Constructional Miscellaneous Hydraulic						
Location	Easement/Right of Way			Work Order						
Project	Villa Park 2016			Elevation						
Northing	Easting			GPS Accuracy						
Coordinate System										
Count	Video	CD	Code	In1	In2	%	JntFr	To	ImRef	Remarks
177.3			TB Tap Break-in	6.000			09			
194.7			MWLS Water Level Sag			25				
233.1			TFC Tap Factory Capped	6.000			10			
236.3			TFC Tap Factory Capped	6.000			03			
242.9			HSV Hole Soil Visible				03			
243.0			TB Tap Break-in	6.000			02			
243.0			FM Fracture Multiple				12 03			
256.8			TB Tap Break-in	6.000			10			
256.8			FM Fracture Multiple				06 05			
259.0			TB Tap Break-in	6.000			10			
262.1		S02	FM Fracture Multiple				06 05			
275.9			TBI Tap Break-in Intruding	6.000	2.000		03			
277.8		F02	FM Fracture Multiple				06 05			
284.3			TFC Tap Factory Capped	6.000			09			
287.3			TFC Tap Factory Capped	6.000			02			
320.2			AMH Manhole							6-025
320.2			FH End of Survey							

320.2 Ft Total Length Surveyed

Scores	Structural:	Pipe Rating 46	Pipe Ratings Index 3.3	Peak 5	Mean Pipe 0.1
	O&M:	Pipe Rating 43	Pipe Ratings Index 2	Peak 8	Mean Pipe 0.1

Tabular Report of PSR 6-025 X for Village of Villa Park

Setup 11	Surveyor Tony	Certificate # U-906-1643	System Owner
Drainage	Survey Customer Village of Villa Park		
P/O #	Date 2016/07/15	Time 13:32	Street rear easement grant-summit
City Villa Park	Further location details		
Up 6-025	Rim to invert	Grade to invert	Rim to grade Ft
Down 6-034	Rim to invert	Grade to invert	Rim to grade Ft
Use Sanitary	Direction Down	Flow control Not Controlled	Media No
Shape Circular	Height 8 Width 8	ins Preclean J	Date Cleaned 2016/07/15
Material Vitrified Clay Pipe	Joint length	Total length 376.7	Length Surveyed 376.7
Lining	Year laid	Year rehabilitated	Weather Dry
Purpose Routine Assessment	Cat		Pressure
Additional info		Structural	O & M
Location Easement/Right of Way		Miscellaneous	Hydraulic
Project Villa Park 2016		Constructional	
Northing		Work Order	
Coordinate System		Elevation	
		GPS Accuracy	

Count	Video	CD Code	In1	In2	%	JntFr	To	ImRef	Remarks
0.0		ST Start of Survey							
0.0		AMH Manhole							6-025
0.0		MWL Water Level			5				
8.3		MMC Material change							VCP TO PVC
11.0		TF Tap Factory	6.000				09		
14.6		MMC Material change							PVC TO VCP
14.6		MWLS Water Level Sag			20				
24.6		MWLS Water Level Sag			35				
27.5		TB Tap Break-in	6.000				02		
27.5		HSV Hole Soil Visible					01		
39.5		TFC Tap Factory Capped	6.000				09		
42.6		TFC Tap Factory Capped	6.000				03		
71.4		TB Tap Break-in	6.000				10		
91.7		MWLS Water Level Sag			45				
99.7		TFC Tap Factory Capped	6.000				09		
102.3		TF Tap Factory	6.000				03		
145.5		TB Tap Break-in	6.000				10		
162.9		TF Tap Factory	6.000				02		
176.8		DAE Deposits Attached Encrustation			5	J	02 04		
204.8		TB Tap Break-in	6.000				02		
204.8		RMC Roots Medium Connection			15		02		
208.7		CL Crack Longitudinal					12		
220.4		TFC Tap Factory Capped	6.000				02		
222.5		FC Fracture Circumferential					07 11		
277.9		TFC Tap Factory Capped	6.000				02		
284.1		FM Fracture Multiple					07 03		
285.2		TB Tap Break-in	6.000				01		
313.4		TB Tap Break-in	6.000				02		
335.8		H Hole				J	12		
339.7		TFC Tap Factory Capped	6.000				02		
376.7		AMH Manhole							6-034

Tabular Report of PSR 6-025 X for Village of Villa Park

Setup	11	Surveyor	Tony	Certificate #	U-906-1643	System Owner	
Drainage		Survey Customer	Village of Villa Park				
P/O #		Date	2016/07/15	Time	13:32	Street	rear easement grant-summit
City	Villa Park	Further location details					
Up	6-025	Rim to invert		Grade to invert		Rim to grade	Ft
Down	6-034	Rim to invert		Grade to invert		Rim to grade	Ft
Use	Sanitary	Direction	Down	Flow control	Not Controlled	Media No	
Shape	Circular	Height	8	Width	8	ins	Preclean J
Material	Vitrified Clay Pipe	Joint length		Total length	376.7	Length Surveyed	376.7
Lining		Year laid		Year rehabilitated		Weather	Dry
Purpose	Routine Assessment	Cat		Pressure			
Additional info						Structural	O & M
Location						Miscellaneous	Hydraulic
Project						Constructional	
Northing						Work Order	
Coordinate System						Elevation	
Count Video						GPS Accuracy	
CD Code		In1	In2	% JntFr	To	ImRef	Remarks
376.7							FH End of Survey

376.7 Ft Total Length Surveyed

Scores	Structural:	Pipe Rating 24	Pipe Ratings Index 3	Peak 5	Mean Pipe 0.1
	O&M:	Pipe Rating 5	Pipe Ratings Index 0.6	Peak 3	Mean Pipe 0

CUES, Inc.  
 3600 Rio Vista Avenue  
 Orlando, FL 32805  
 Phone: 407-849-0190  
 Fax: 407-425-1569



**Main Inspection with Pipe-Run and Scoring**

Project Name:	Mainline ID:	City:	Address:	
Street Referendum Project	3-090/3-091	Villa Park	384 N Mission	
Start date/time:	Pipe width:	Pipe height:	Pipe type:	Surface condition:
4/20/2016	8	8	Concrete	Parkway
Direction:	Surveyed footage:	Weather:	Tape/Media #	
Downstream	425.6	Dry		

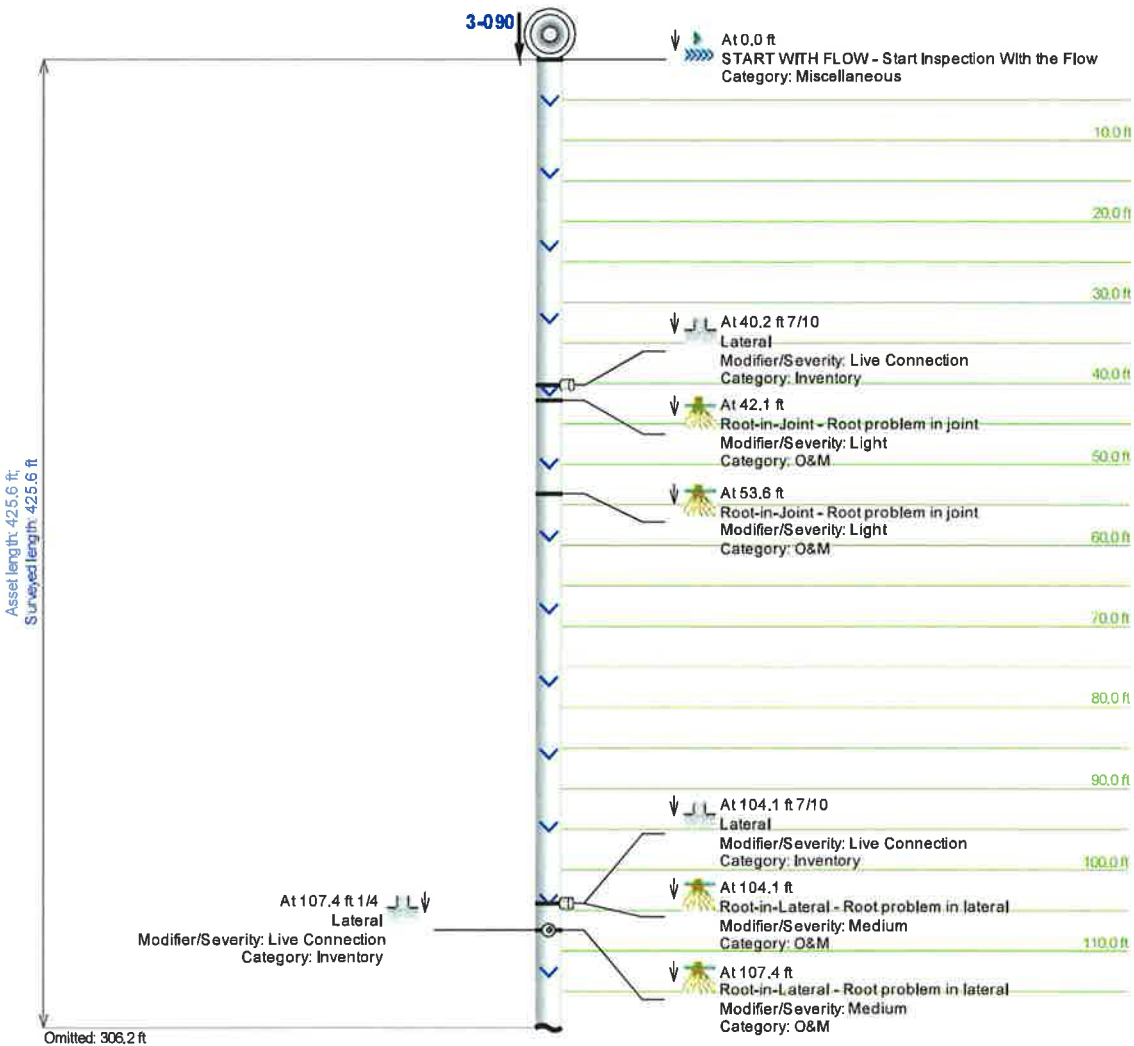

CUES, Inc.  
 3600 Rio Vista Avenue  
 Orlando, FL 32805  
 Phone: 407-849-0190  
 Fax: 407-425-1569



Project Name: <b>Street Referendum Project</b>	Mainline ID: <b>3-090/3-091</b>	City: <b>Villa Park</b>	Address: <b>384 N Mission</b>
Start date/time: <b>4/20/2016</b>	Pipe width: <b>8</b>	Pipe height: <b>8</b>	Pipe type: <b>Concrete</b>
Direction: <b>Downstream</b>	Surveyed footage: <b>425.6</b>	Weather: <b>Dry</b>	Surface condition: <b>Parkway</b>
			Tape/Media #

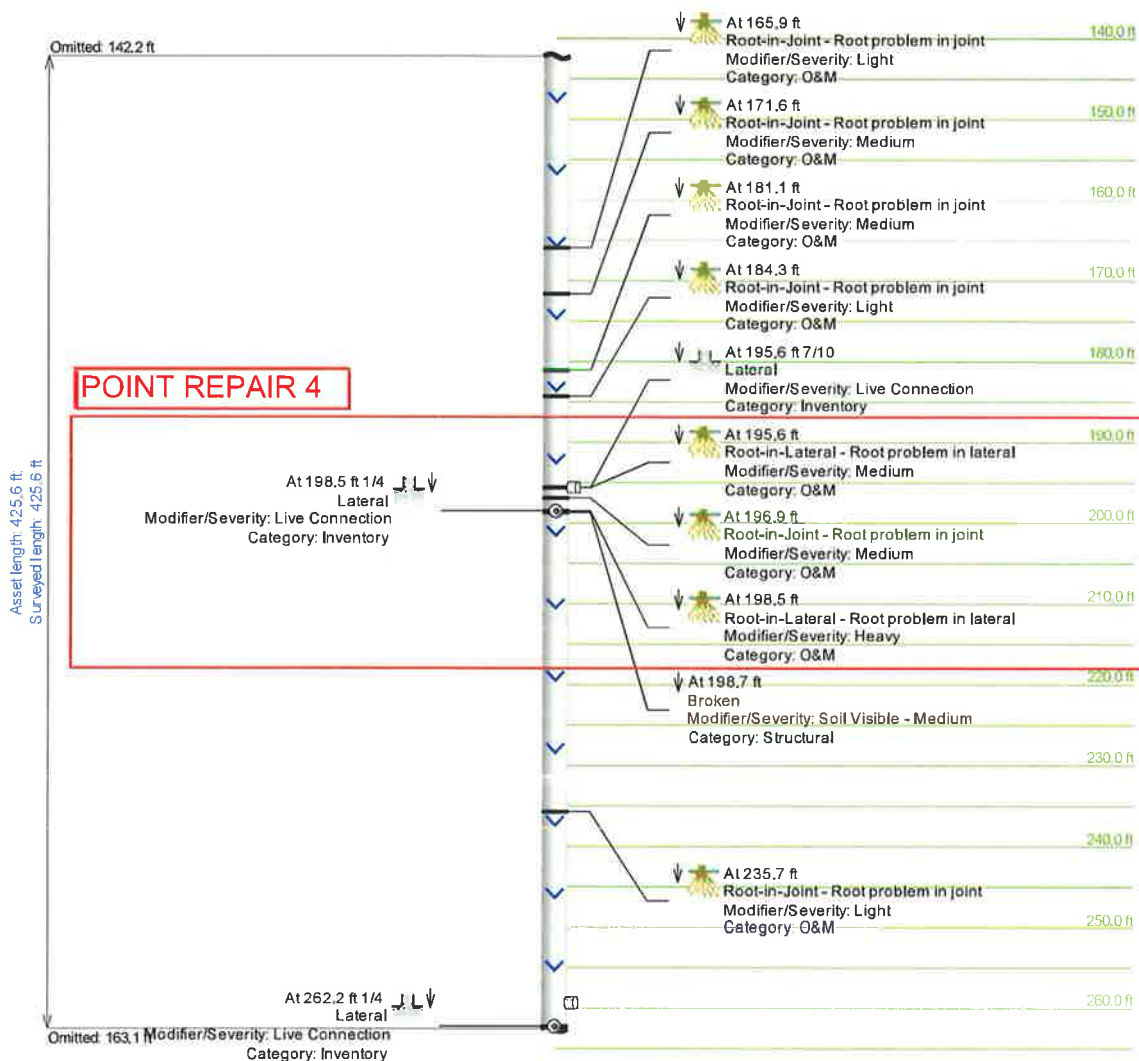

CUES, Inc.  
 3600 Rio Vista Avenue  
 Orlando, FL 32805  
 Phone: 407-849-0190  
 Fax: 407-425-1569



Project Name: <b>Street Referendum Project</b>	Mainline ID: <b>3-090/3-091</b>	City: <b>Villa Park</b>	Address: <b>384 N Mission</b>
Start date/time: <b>4/20/2016</b>	Pipe width: <b>8</b>	Pipe height: <b>8</b>	Pipe type: <b>Concrete</b>
Direction: <b>Downstream</b>	Surveyed footage: <b>425.6</b>	Weather: <b>Dry</b>	Surface condition: <b>Parkway</b>
		Tape/Media #	

**5-FOOT T-LINER**

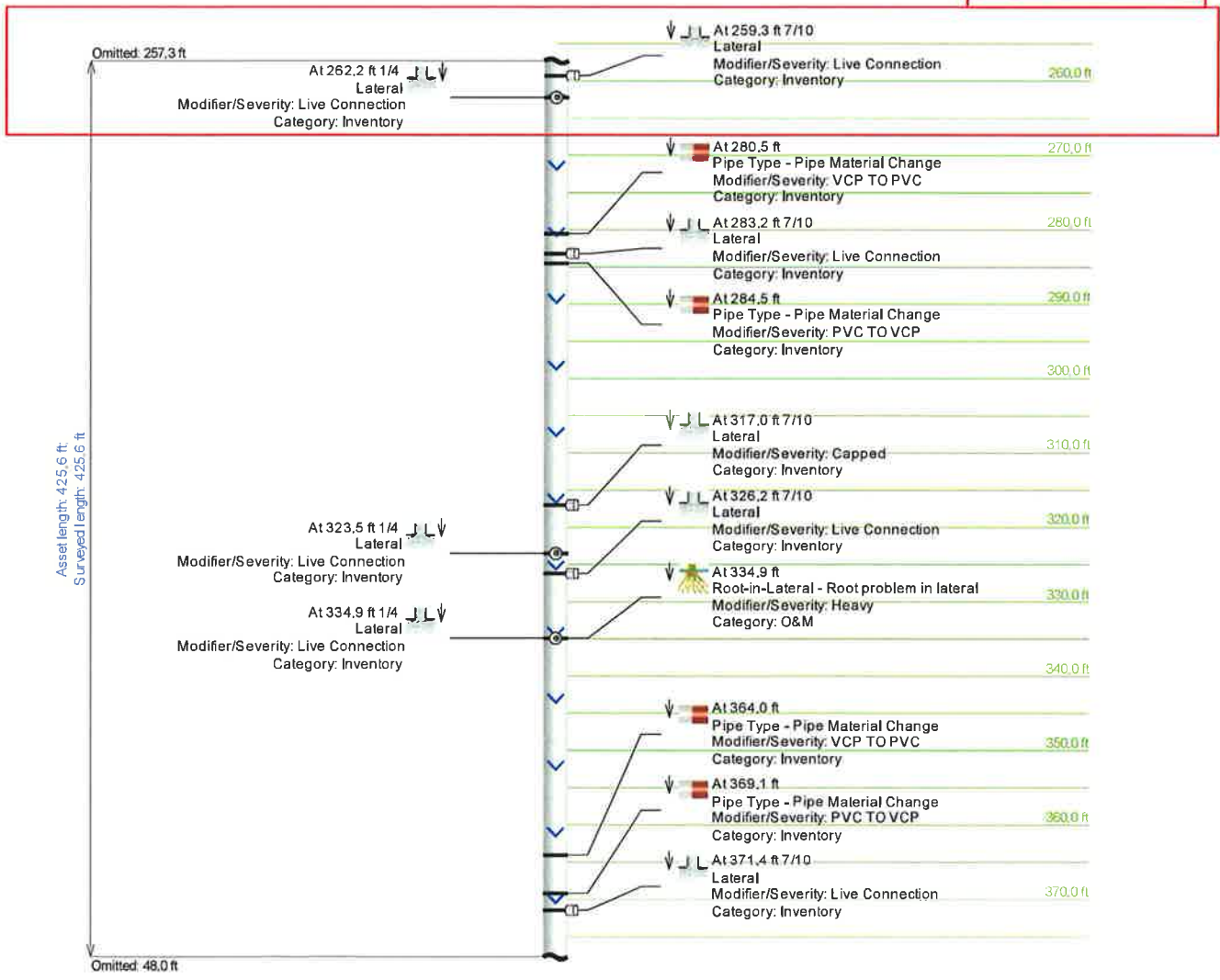

CUES, Inc.  
 3600 Rio Vista Avenue  
 Orlando, FL 32805  
 Phone: 407-849-0190  
 Fax: 407-425-1569



Project Name: <b>Street Referendum Project</b>	Mainline ID: <b>3-090/3-091</b>	City: <b>Villa Park</b>	Address: <b>384 N Mission</b>
Start date/time: <b>4/20/2016</b>	Pipe width: <b>8</b>	Pipe height: <b>8</b>	Pipe type: <b>Concrete</b>
Direction: <b>Downstream</b>	Surveyed footage: <b>425.6</b>	Weather: <b>Dry</b>	Surface condition: <b>Parkway</b>
			Tape/Media #

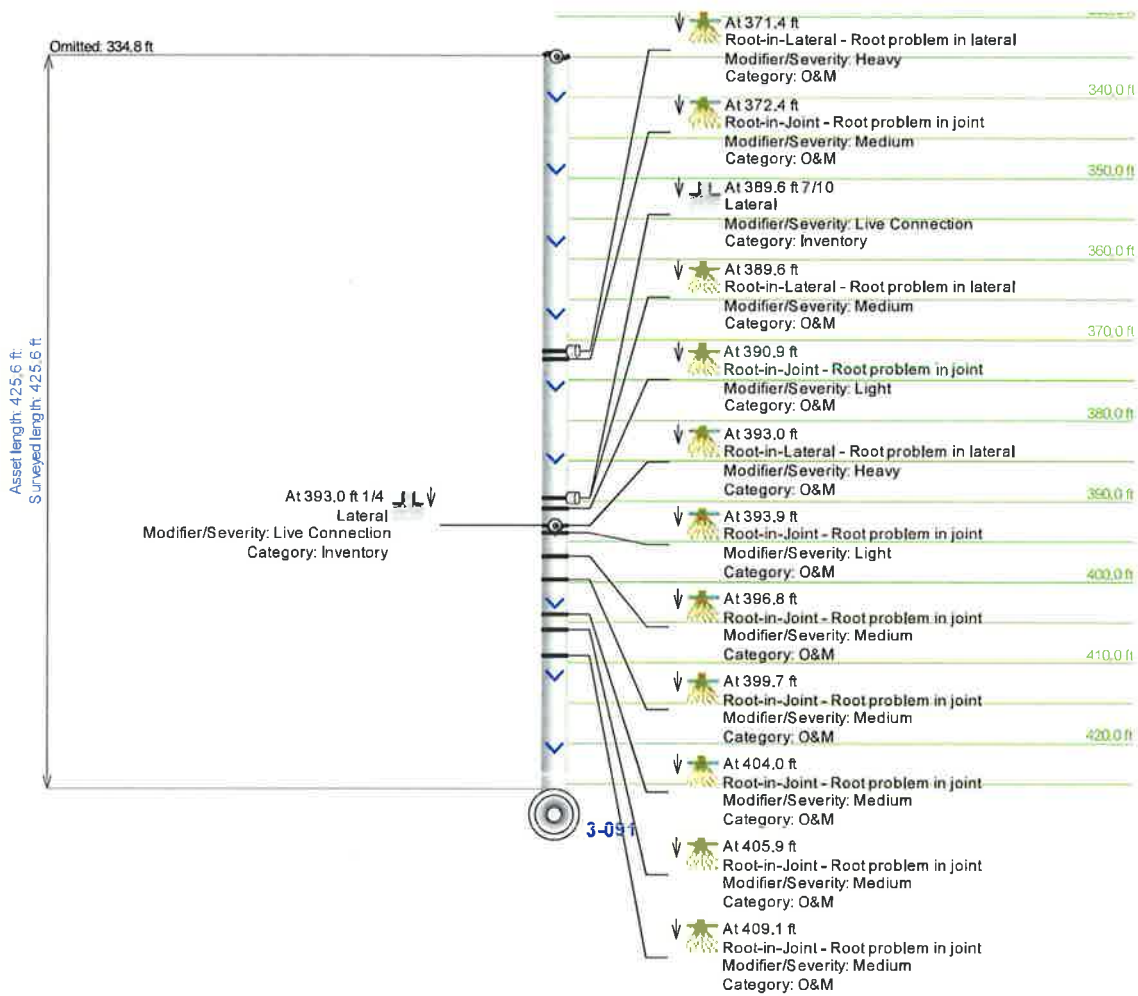

CUES, Inc.  
3600 Rio Vista Avenue  
Orlando, FL 32805  
Phone: 407-849-0190  
Fax: 407-425-1569



Main Inspection with Pipe-Run and Scoring

Project Name:	Mainline ID:	City:	Address:	
Street Referendum Project	7-017/7-016	Villa Park	118 E. Monroe	
Start date/time:	Pipe width:	Pipe height:	Pipe type:	Surface condition:
9/30/2015	8	8	Clay	Asphalt
Direction:	Surveyed footage:	Weather:	Tape/Media #	
Downstream	219.8	Dry		

Existing lateral service not reinstated after lining and installation of new service lateral from cleanout in parkway to Manhole 7-017

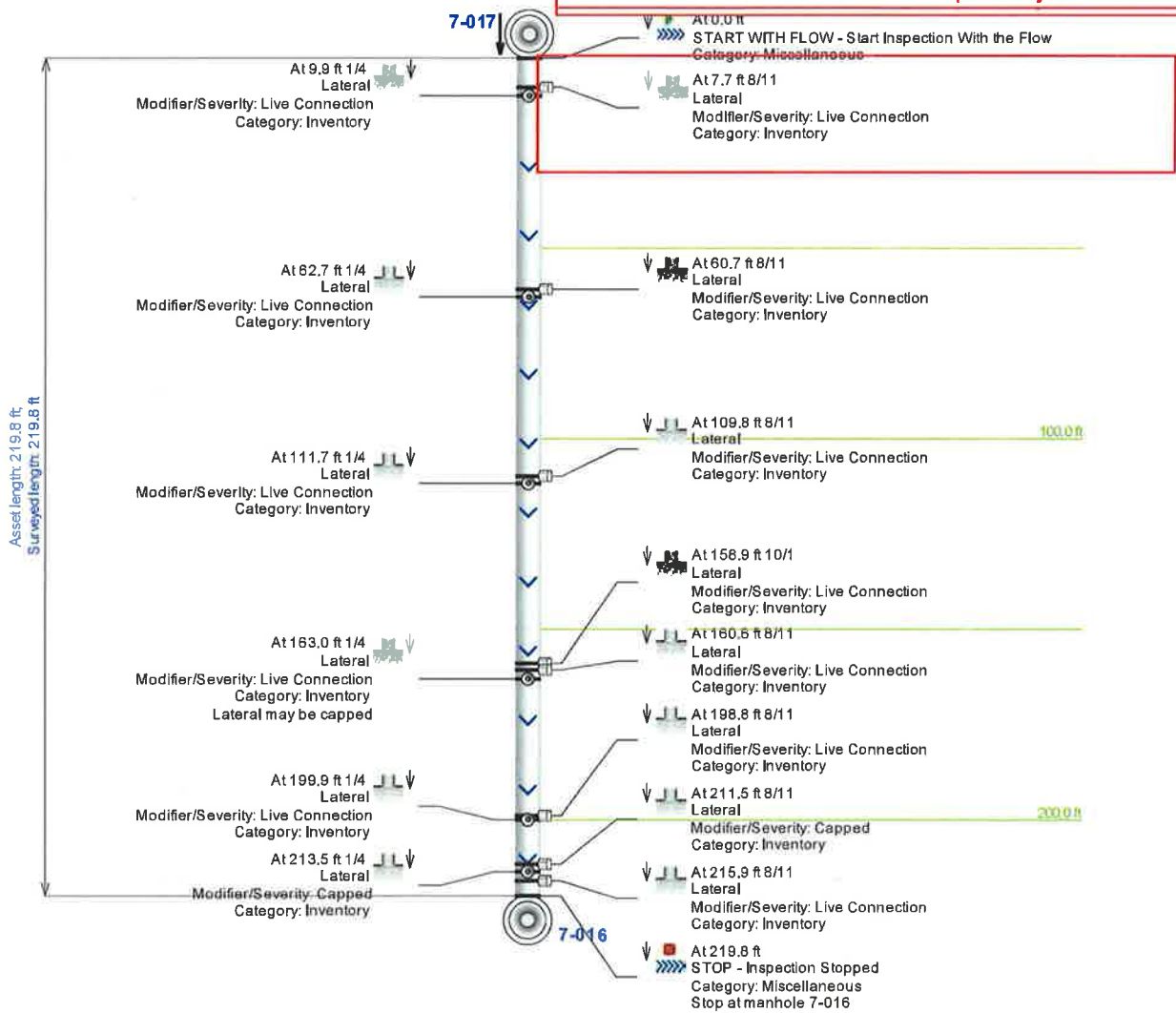

**Point Repair 1**

838 S Euclid Ave, Villa Park, IL 60181



#1: Driveway of 838 Grant Avenue (Possible Access Route)



#2: End of Driveway (Possible Access Route) – Fence to be removed and re-erected (R&R-E)



#3: Approximate Point Repair (PR) Location. Looking SW (838 Grant's Backyard)



#4: Fence to be removed and re-erected ; Overhead utilities nearby (838 Grant's Backyard)



#5: Remove and replace (R&R) Concrete Patio Stones as needed (838 Grant's Backyard)

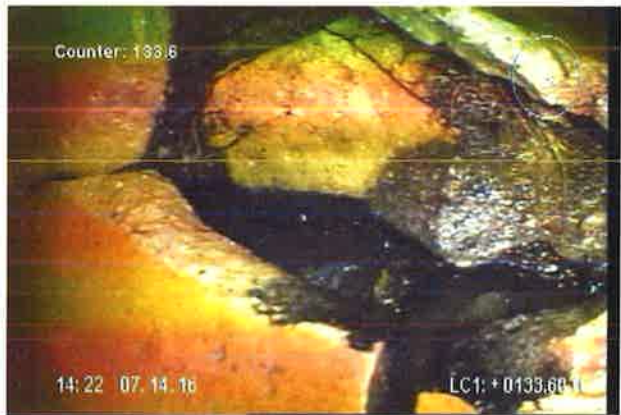

#6: Pipe Defect at 133.6 feet from MH 6-018 (tap break-in, hole void visible and fracture multiple)

**Point Repair 2**

935 S Summit Ave, Villa Park, IL 60181



#1: 935 Summit Avenue

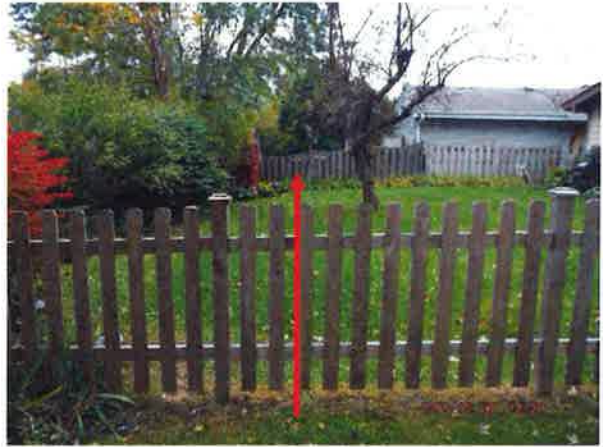

#2: Possible Access Route from Frank St.; Fences R&R-E of 931 Summit Ave. Looking South.



#3: Approximate PR Location. Looking NE (935 Summit's Backyard)



#4: Fences R&R-E; Overhead and underground utilities nearby (935 Summit's Backyard)



#5: Possible Access Route to PR from Frank St. looking North; Fences R&R-E of 931/935 Summit

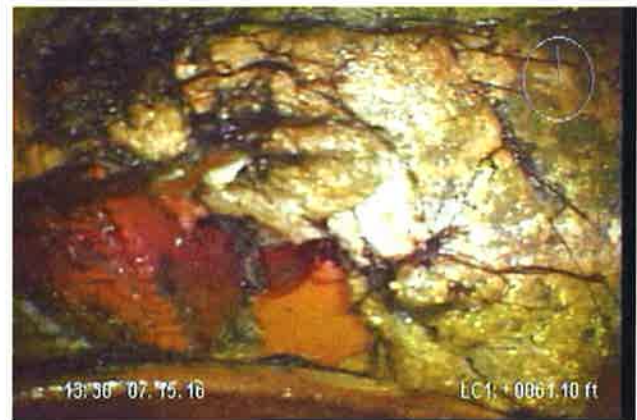

#6: Pipe Defect from 52.7 to 61.1 feet from MH 6-170 (Broken pipe)

**Point Repair 3**

1011 S Summit Ave, Villa Park, IL 60181



#1: Driveway of 1011 South Summit (Possible Access Route)



#2: End of Driveway (Possible Access Route); Fence R&R-E



#3: Overhead utilities (1011 South Summit's Backyard)



#4: Approximate PR Location Looking North from 1011 South Summit; Fence R&R-E



#5: Overhead utilities (1011 South Summit's Backyard)



#6: Pipe Defect at 27.5 feet from MH 6-025 (tap break-in, hole void visible)

**Point Repair 4**

In the Parkway in front of 639 W Pleasant Ave, Villa Park, IL 60181



#1: House on 639 Pleasant nearby PR



#2: Approximate PR Location Looking South;  
Tree removal (36 units)



#3: Approximate PR Location Looking East; Tree  
removal (36 units)

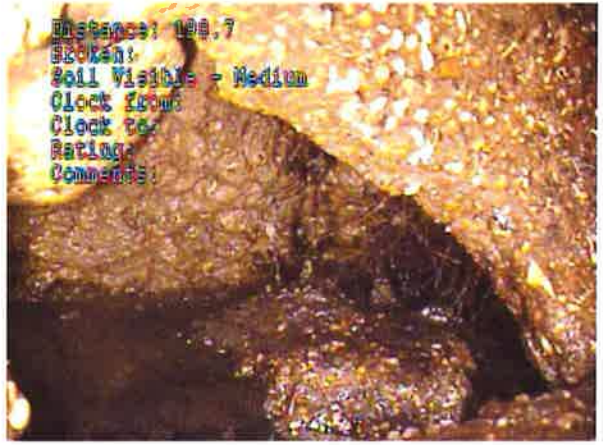

#4: Pipe Defect at 198.7 feet from MH 3-090  
(Broken pipe, hole void visible)

#5:

#6:

**New Lateral Service 1**

Center of Monroe Street nearby 118 E Monroe St, Villa Park, IL 60181



#1: House on 115 Monroe St nearby existing lateral service connection – Looking South



#2: Road Surface removed; Concrete Subbase – looking West



#3: MH 7-017 on Monroe St. nearby existing lateral service connection – Looking Northwest



#4: MH 7-017 on Monroe St. nearby 118 E Monroe – Looking Northeast



#5: Approximate Location of the existing lateral service connection – Looking North

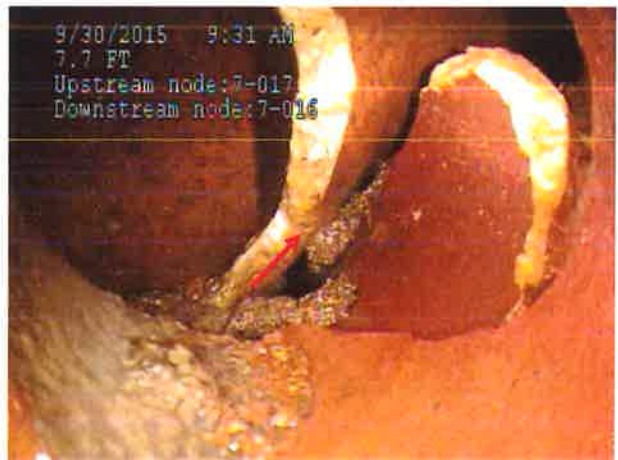

#5: Pipe Defect at 7.7 feet from MH 7-017 (collapsed existing lateral service)



JOB NO.	USMH	USMH	REPAIR LENGTH	SERVICE	DEPTH	SURFACE	PIPE LENGTH
PR-1	6-018	6-017	8'	S	APPROX. 5.8'	BACKYARD	337.9'

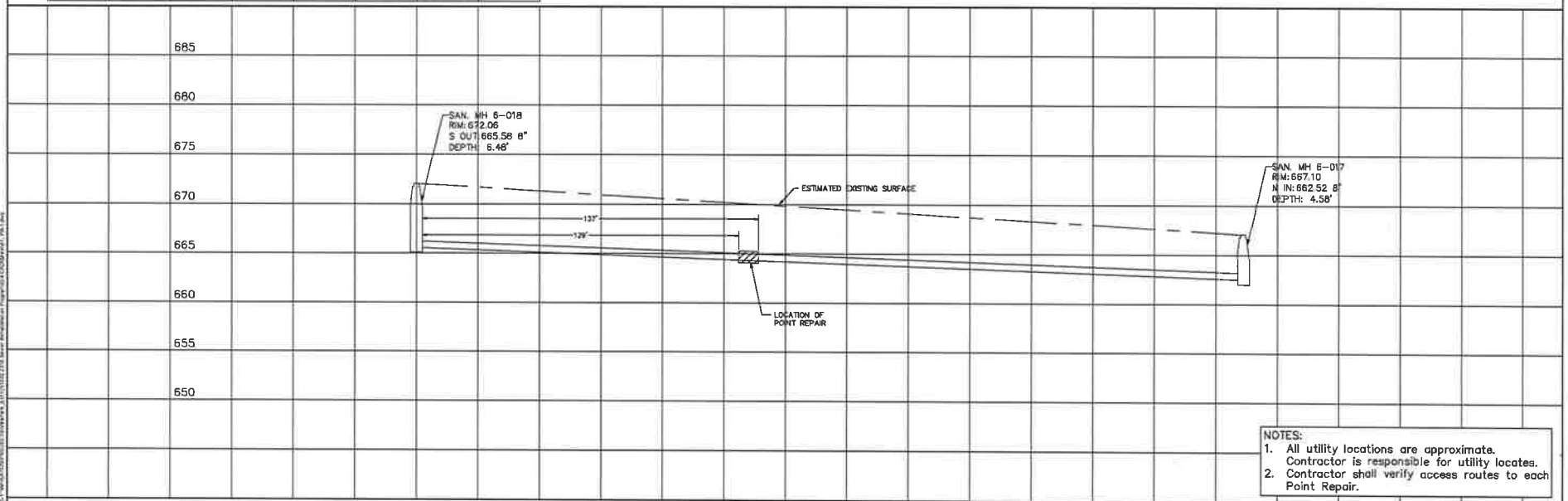

NOTES:  
 1. All utility locations are approximate. Contractor is responsible for utility locates.  
 2. Contractor shall verify access routes to each Point Repair.

DESIGNED: Y GALLIN			2019 SEWER REHABILITATION PROGRAM	PLAN AND PROFILE POINT REPAIR 1	COUNTY TOTAL SHEETS	COUNTY SHEETS NO.
DRAWN: Y GALLIN					DUPAGE	E 1
CHECKED: C MORLEY					STA.	TO STA.
DATE: JANUARY 2018					PROJECT NO. 11-2010-00	SCALE: HORIZONTAL 1" = 20' VERTICAL 1" = 5'

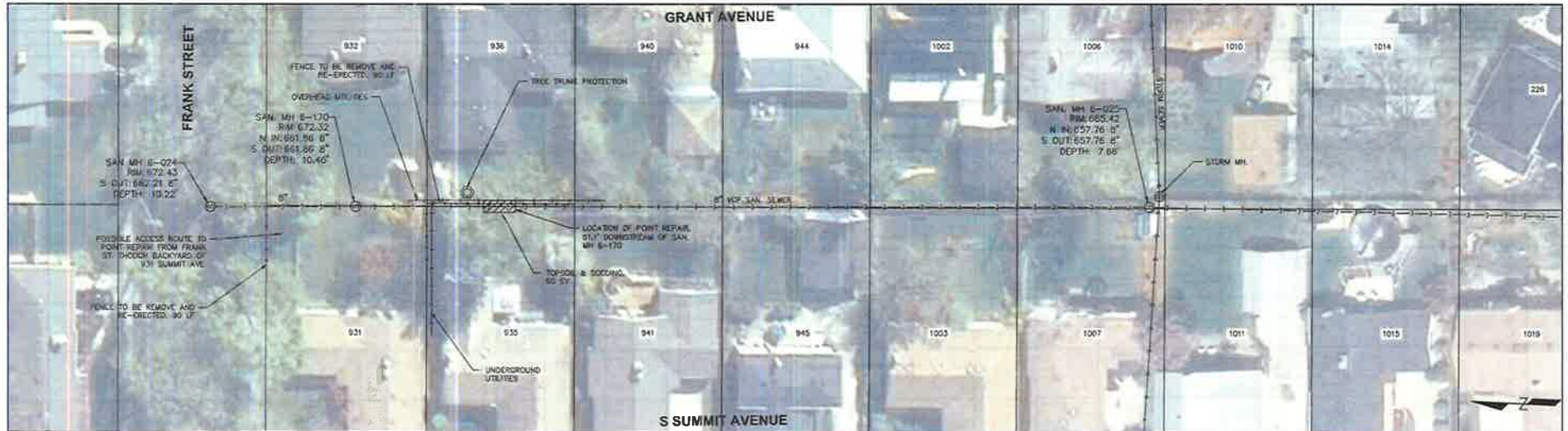

JOB NO.	USMH	DSMH	REPAIR LENGTH	SERVICE	DEPTH	SURFACE	PIPE LENGTH
PR-2	6-170	6-025	13'	1	APPROX. 10'	BACKYARD	320.2'

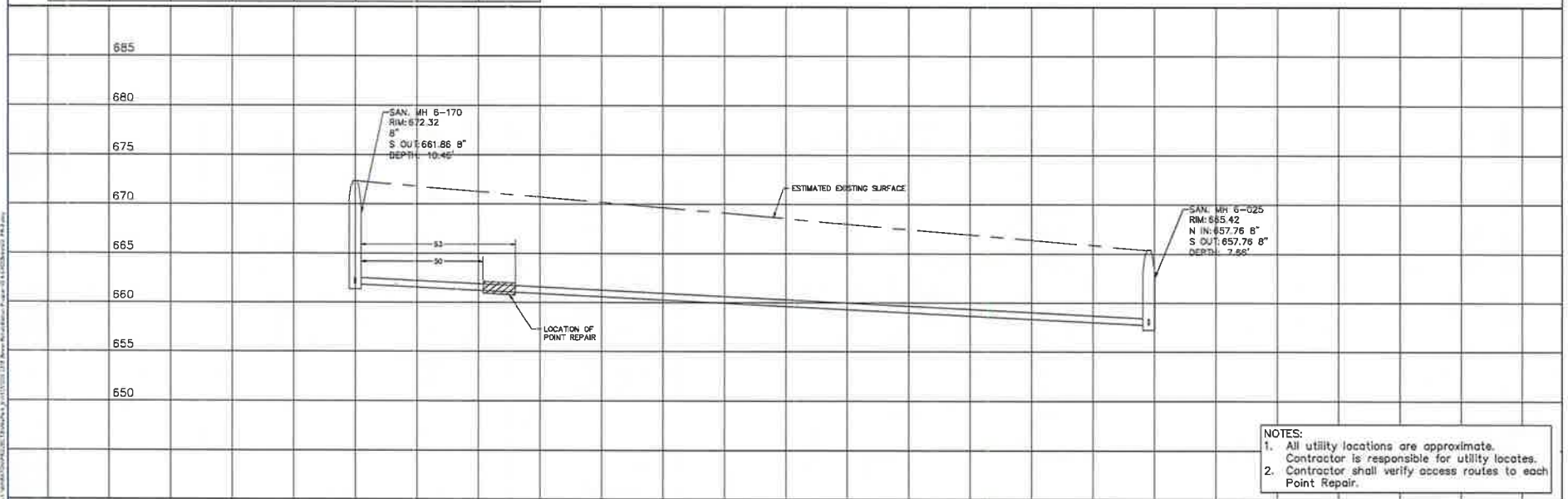

- NOTES:
- All utility locations are approximate. Contractor is responsible for utility locates.
  - Contractor shall verify access routes to each Point Repair.

DESIGNED: Y GALLIN		2019 SEWER REHABILITATION PROGRAM	PLAN AND PROFILE POINT REPAIR 2	COUNTY TOTAL SHEETS NO.
DRAWN: Y GALLIN				DURAGE 8 2
CHECKED: C MORLEY				STA TO STA
DATE: JANUARY 2018				PROJECT NO. 11-2819-00



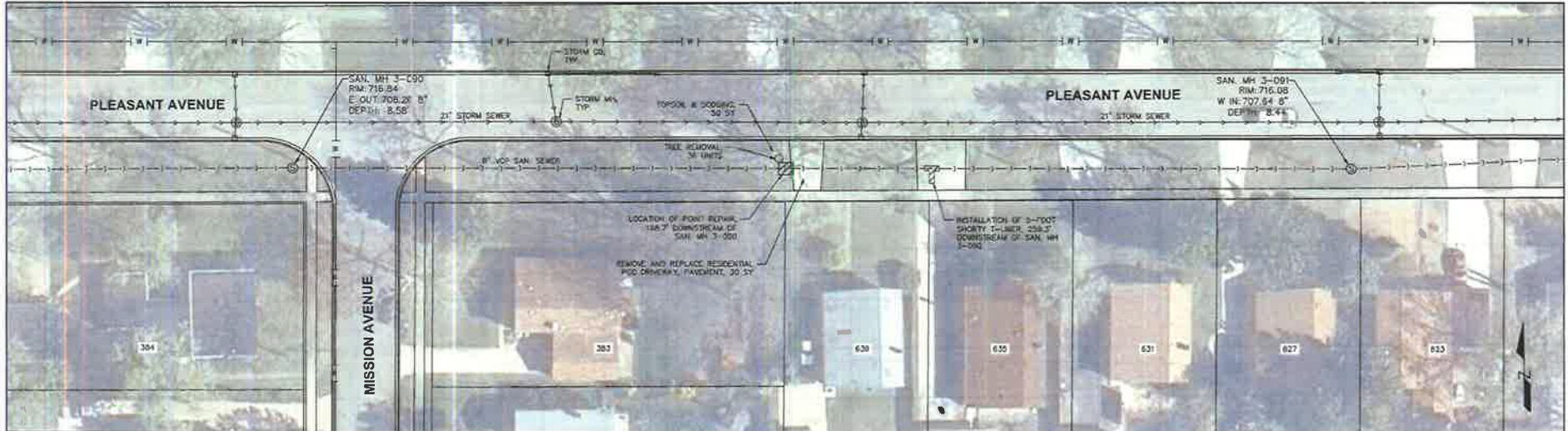

JOB NO.	USMH	DSMH	REPAIR LENGTH	SERVICE	DEPTH	SURFACE	PIPE LENGTH
PR-4	3-090	3-091	6'	2	APPROX. 8.5'	PARKWAY	425.6'

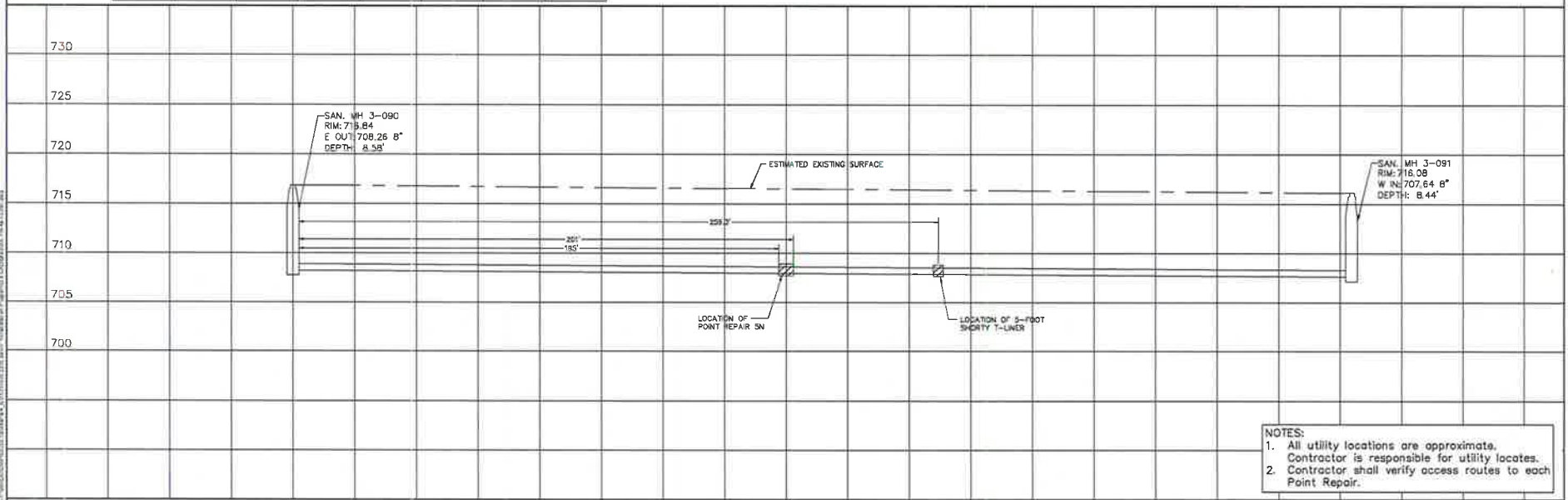

NOTES:  
 1. All utility locations are approximate.  
 Contractor is responsible for utility locates.  
 2. Contractor shall verify access routes to each Point Repair.

DESIGNED: Y GALLIN			2019 SEWER REHABILITATION PROGRAM	PLAN AND PROFILE POINT REPAIR 4 AND T-LINER	COUNTY TOTAL SHEET NO. DUPAGE 8 4
DRAWN: Y GALLIN					HORIZONTAL SCALE: 1" = 20' COUNTY TOTAL SHEET NO.
CHECKED: C MORLEY					VERTICAL SCALE: 1" = 5' COUNTY TOTAL SHEET NO.
DATE: JANUARY 2018					STA. TO STA. PROJECT NO. 11-2910-00



JOB NO.	USMH	OSMH	REPAIR LENGTH	SERVICE	DEPTH	SURFACE	PIPE LENGTH
3	7-017	7-016	6'	S	APPROX. 11.4'	ROADWAY	219.8'

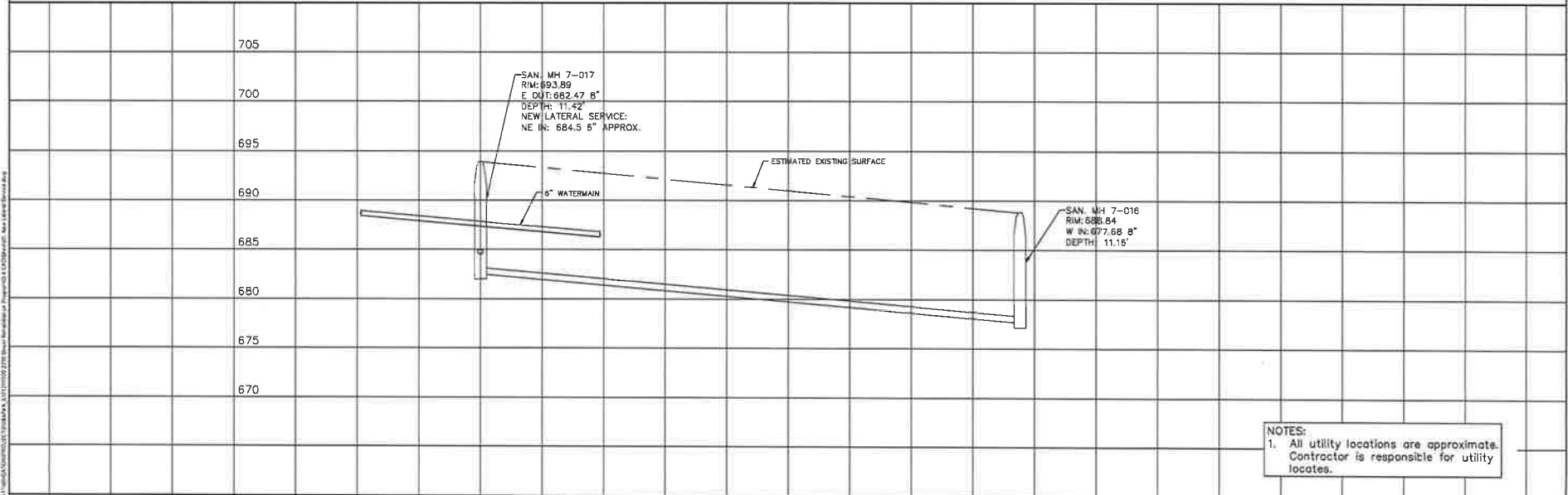

NOTES:  
1. All utility locations are approximate. Contractor is responsible for utility locates.

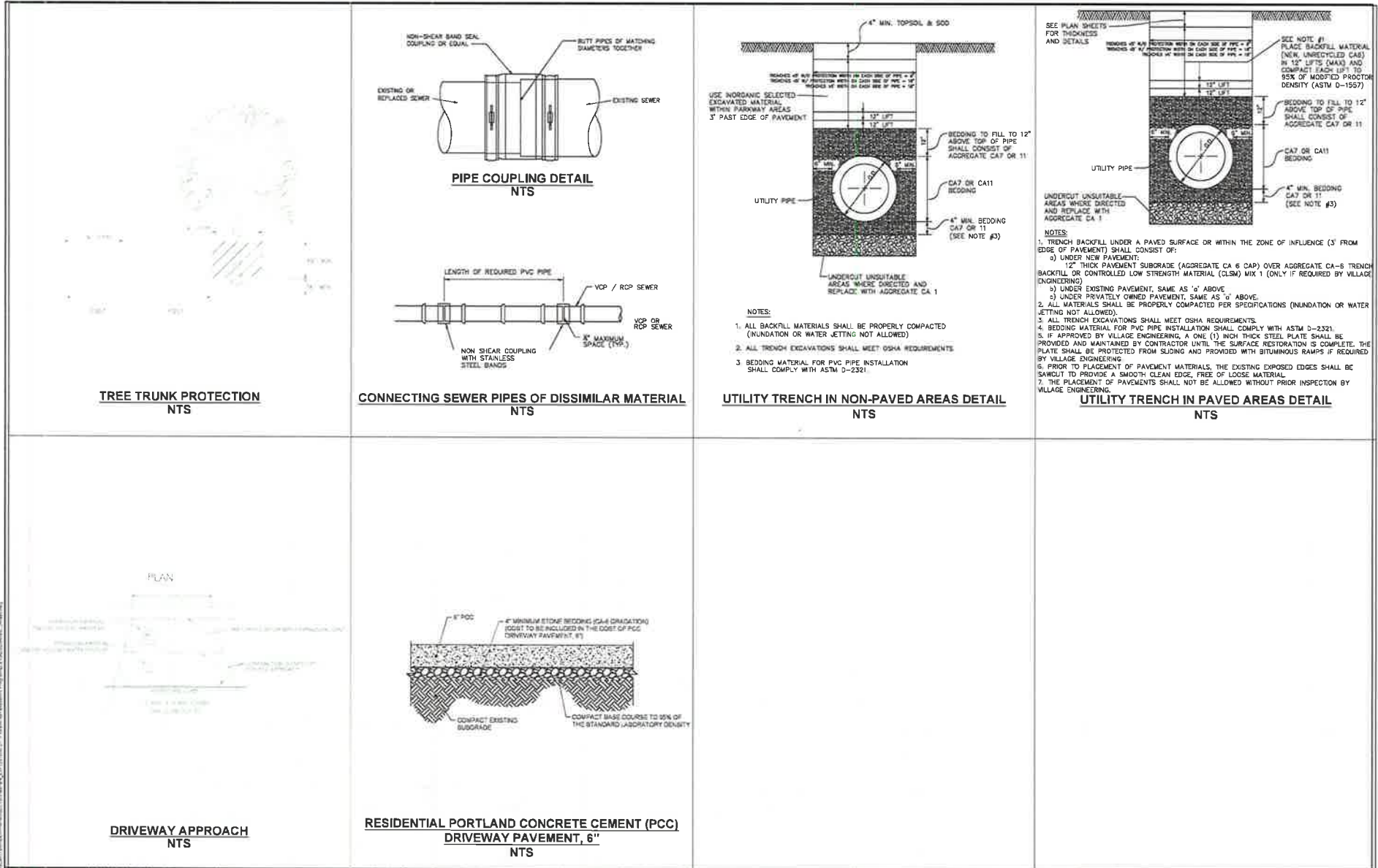

- NOTES:**
1. ALL BACKFILL MATERIALS SHALL BE PROPERLY COMPACTED (NUNDATION OR WATER JETTING NOT ALLOWED)
  2. ALL TRENCH EXCAVATIONS SHALL MEET OSHA REQUIREMENTS
  3. BEDDING MATERIAL FOR PVC PIPE INSTALLATION SHALL COMPLY WITH ASTM D-2321.

- NOTES:**
1. TRENCH BACKFILL UNDER A PAVED SURFACE OR WITHIN THE ZONE OF INFLUENCE (3' FROM EDGE OF PAVEMENT) SHALL CONSIST OF:
    - a) UNDER NEW PAVEMENT: 12" THICK PAVEMENT SUBGRADE (AGGREGATE CA 6 CAP) OVER AGGREGATE CA-6 TRENCH BACKFILL OR CONTROLLED LOW STRENGTH MATERIAL (CLSM) MIX 1 (ONLY IF REQUIRED BY VILLAGE ENGINEERING)
    - b) UNDER EXISTING PAVEMENT, SAME AS 'a' ABOVE
    - c) UNDER PRIVATELY OWNED PAVEMENT, SAME AS 'a' ABOVE.
  2. ALL MATERIALS SHALL BE PROPERLY COMPACTED PER SPECIFICATIONS (NUNDATION OR WATER JETTING NOT ALLOWED).
  3. ALL TRENCH EXCAVATIONS SHALL MEET OSHA REQUIREMENTS.
  4. BEDDING MATERIAL FOR PVC PIPE INSTALLATION SHALL COMPLY WITH ASTM D-2321.
  5. IF APPROVED BY VILLAGE ENGINEERING, A ONE (1) INCH THICK STEEL PLATE SHALL BE PROVIDED AND MAINTAINED BY CONTRACTOR UNTIL THE SURFACE RESTORATION IS COMPLETE. THE PLATE SHALL BE PROTECTED FROM SLIDING AND PROVIDED WITH BITUMINOUS RAMPS IF REQUIRED BY VILLAGE ENGINEERING
  6. PRIOR TO PLACEMENT OF PAVEMENT MATERIALS, THE EXISTING EXPOSED EDGES SHALL BE SAWCUT TO PROVIDE A SMOOTH CLEAN EDGE, FREE OF LOOSE MATERIAL.
  7. THE PLACEMENT OF PAVEMENTS SHALL NOT BE ALLOWED WITHOUT PRIOR INSPECTION BY VILLAGE ENGINEERING.

DESIGNED: Y GALLIN			2019 SEWER REHABILITATION PROGRAM	DETAILS 1	SCALES	COUNTY	TOTAL SHEETS		
DRAWN: Y GALLIN					HORIZONTAL: -	SUPPAGE	6	6	
CHECKED: C MORLEY					VERTICAL: -	STA.	-	TO STA.	-
DATE: JANUARY 2018					PROJECT NO. 11-2819-00				

**OWNER COPY**

**CONTRACT**

**2019 SEWER REHABILITATION PROGRAM  
VILLAGE OF VILLA PARK**

**APPENDIX 3**

**SEWER LINING AND GROUTING SCHEDULES  
SEWER LINING AND GROUTING LOCATION MAPS (EXHIBITS 1 TO 5)**

**VILLAGE OF VILLA PARK  
2019 SEWER REHABILITATION PROGRAM  
LINING AND GROUTING SCHEDULE**

Upstream Manhole	Downstream Manhole	Location	Length (ft)	Pipe Diam. (in)	Material	Service Laterals	Protruding Taps	Comments
<b>BASE BID</b>								
1-024	1-023	N VILLA	103	18	CONC	0	0	
1-020	1-019	N VILLA	341	21	CONC	0	0	
3-024	3-023	434 ADDISON AVE	505	10	CONC	7	0	
3-030	3-029	401 THIRD AVE	320	10	CONC	8	0	
3-035	3-034	610 THIRD AVE	323	10	CONC	12	1	
3-040	3-039	3RD AVE IFO 738	336	10	CONC	10	1	
3-043	3-044	714 SECOND AVE	414	10	CONC	13	0	
3-044	3-045	634 SECOND AVE	328	10	CONC	9	0	
3-045	3-046	SECOND/SUNSET	329	10	CONC	13	1	
3-050	3-051	2ND ST IFO 367	322	10	CONC	3	0	
3-055	3-054	N.BIERMAN	351	10	CONC	12	0	
3-056	3-055	N.BIERMAN	358	10	CONC	12	0	
3-059	3-058	N.BIERMAN	386	10	CONC	11	0	
3-060	3-059	530 BIERMANN AV	394	10	CONC	12	0	
3-061	3-060	N.BIERMAN @SNST	388	10	CONC	11	2	
3-080	3-079	359 N MISSION	354	8	CONC	6	0	
3-081	3-080	379 N MISSION	297	8	CONC	11	0	
3-082	3-079	MISSION	287	10	VCP	6	0	
3-083	3-082	731 W TERRACE	383	10	CONC	11	1	
3-085	3-084	356 N LINCOLN AVE	374	8	CONC	13	0	
3-086	3-085	380 N LINCOLN AVE	351	8	CONC	13	0	
3-087	3-088	PLEASANT	328	8	VCP	0	0	
3-088	3-089	PLEASANT	151	8	VCP	2	0	
3-089	3-090	PLEASANT	387	8	VCP	6	0	
3-090	3-091	PLEASANT	430	8	CONC	12	0	
3-091	3-073	PLEASANT	406	8	CONC	12	0	
3-095	3-093	645 W. VERMONT	210	8	CONC	6	1	
3-096	3-095	725 W. VERMONT	325	8	CONC	11	0	

VILLAGE OF VILLA PARK  
 2019 SEWER REHABILITATION PROGRAM  
LINING AND GROUTING SCHEDULE

Upstream Manhole	Downstream Manhole	Location	Length (ft)	Pipe Diam. (in)	Material	Service Laterals	Protruding Taps	Comments
3-097	3-096	VERMONT	294	8	CONC	7	0	
3-098	3-099	LINCOLN AVE	167	8	CONC	2	0	
3-099	3-100	PLYMOUTH	293	8	CONC	7	0	
3-100	3-101	PLYMOUTH	236	8	CONC	8	0	
3-101	3-102	PLYMOUTH	347	8	CONC	10	0	
3-102	3-071	622 W. PLYMOUTH	290	8	CONC	10	0	
3-103	3-099	LINCOLN AVE	283	8	CONC	6	0	
3-104	3-103	LINCOLN AVE	297	8	CONC	3	0	
3-105	3-106	727 W. MERLE	332	8	CONC	11	1	
3-106	3-107	701 W. MERLE	252	8	CONC	6	0	
3-107	3-108	627 W. MERLE	311	8	CONC	10	0	
3-108	3-070	611 W. MERLE	145	8	CONC	6	1	
6-014	6-015	842 MYRTLE AVENUE	343	8	VCP	16	1	In Backyard. <u>LATERALS TO BE GROUTED ONLY (ALREADY LINED)</u> . Protruding taps to be confirmed.
6-016	6-008	928 EUCLID AVE	340	8	VCP	9	0	In Backyard. LATERALS TO BE GROUTED.
6-017	6-016	928 EUCLID AVE	333	8	VCP	11	0	In Backyard. LATERALS TO BE GROUTED.
6-018	6-017	W/ 826 EUCLID	336	8	VCP	12	0	In Backyard. LATERALS TO BE GROUTED.
6-024	6-170	931 SUMMIT AVE	59	8	VCP	0	0	In Backyard.
6-170	6-025	931 SUMMIT AVE	323	8	VCP	12	0	In Backyard. LATERALS TO BE GROUTED.
6-025	6-034	217 TERRY	375	8	VCP	6	0	In Backyard. LATERALS TO BE GROUTED.
6-068	6-067	1109 EUCLID AVE	353	8	VCP	9	1	In Backyard. <u>LATERALS TO BE GROUTED ONLY (ALREADY LINED)</u> . Protruding taps to be confirmed.
6-070	6-071	R/ 205 JULIA	255	8	VCP	6	0	In Backyard. LATERALS TO BE GROUTED.
6-071	6-074	230 JULIA	294	8	VCP	4	0	In Backyard. LATERALS TO BE GROUTED.
6-031	6-030	1127 S. SUMMIT	176	8	VCP	3	1	
6-036	6-181	SUMMIT AVENUE	293	15	VCP	5	0	
6-038	6-037	E VAN BUREN & S. CORNE	215	8	VCP	9	2	
6-047	6-046	SUMMIT	62	8	VCP	0	0	
6-048	6-047	SUMMIT	197	8	VCP	4	0	
6-079	6-046	SUMMIT	260	8	VCP	5	0	

**VILLAGE OF VILLA PARK  
2019 SEWER REHABILITATION PROGRAM  
LINING AND GROUTING SCHEDULE**

Upstream Manhole	Downstream Manhole	Location	Length (ft)	Pipe Diam. (in)	Material	Service Laterals	Protruding Taps	Comments
6-089	6-090	1129 ARDMORE AV	192	8	VCP	3	0	Near Sugar Creek. LATERALS TO BE GROUTED.
6-090	6-107	1125 S. ARDMORE	183	8	VCP	2	0	Near Sugar Creek. LATERALS TO BE GROUTED.
6-120	6-119	ARDMORE 250	297	10	VCP	0	0	Near Sugar Creek.
6-149	6-181	SUMMIT & CONGRESS	147	18	CONC	2	0	
6-150	6-167	ARDMORE 25'RAND	222	10	VCP	0	0	Near Sugar Creek.
6-088	6-150	1217 S. ARDMORE AVE	328	10	VCP	0	0	Near Sugar Creek.
6-927	6-088	1231 ARDMORE	283	10	VCP	3	0	Near Sugar Creek. LATERALS TO BE GROUTED.
6-151	6-927	ARDMORE/HS	315	10	VCP	0	0	Near Sugar Creek.
6-152	6-151	WILLOWBROOK HS	299	10	VCP	0	0	Near Sugar Creek.
6-153	6-152	WILLOWBROOK HS	296	10	VCP	0	0	Near Sugar Creek.
6-167	6-107	ARDMORE/CONGRES	34	10	VCP	0	0	Near Sugar Creek.
6-238	6-120	ARDMORE AVE	348	10	VCP	0	0	Near Sugar Creek.
7-011	7-012	134 ADAMS ST	216	8	VCP	10	0	
7-012	7-013	ADAMS/SUMMIT	217	8	VCP	2	0	
7-014	7-013	SUMMIT	221	8	VCP	3	0	
7-017	7-016	118 E. MONROE	220	8	VCP	13	0	After new lateral is installed.
7-018	7-017	102 E. MONROE	206	8	VCP	7	0	
7-019	7-018	102 E. MONROE	206	8	VCP	7	0	
7-020	7-019	15 E. MONROE	210	8	VCP	6	1	
7-023	7-022	133 MADISON ST	221	8	VCP	1	0	
7-024	7-023	121 E MADISON ST	212	8	VCP	5	0	
7-025	7-024	101 E MADISON	208	8	VCP	1	4	
7-026	7-025	MADISON/CORNELL	216	8	VCP	4	0	
Total 8":			12,812					
Total 10":			7,846					
Total 15":			293					
Total 18":			250					
Total 21":			341					
<b>Grand Total:</b>			<b>21,542</b>			<b>508</b>	<b>19</b>	

**VILLAGE OF VILLA PARK  
2019 SEWER REHABILITATION PROGRAM  
LINING AND GROUTING SCHEDULE**

Upstream Manhole	Downstream Manhole	Location	Length (ft)	Pipe Diam. (in)	Material	Service Laterals	Protruding Taps	Comments
<b>ALTERNATE NO. 1 (LINING ONLY)</b>								
3-026	3-025	ADDISON RD	135	8	VCP	1	0	
3-037	3-035	638 THIRD AVE	142	10	CONC	2	0	
3-039	3-037	3RD AVE & RIDGE	181	10	CONC	8	0	
3-046	3-047	2ND ST IFO 559	323	10	CONC	10	0	
3-062	3-061	636 BIERMANN AV	392	10	CONC	12	2	
3-063	3-062	718 BIERMANN AV	406	10	CONC	12	0	
3-069	3-070	WESTMORE	322	10	CONC	5	1	Service Laterals and Protruding taps shall be confirmed during pre-construction televising.
3-070	3-071	WESTMORE	342	10	CONC	4	0	
3-071	3-138	WESTMORE	517	10	CONC	12	1	
3-138	3-072	WESTMORE	105	10	CONC	3	0	
3-092	3-072	619 W. VERMONT	244	8	CONC	6	0	
3-093	3-092	631 W. VERMONT	151	8	CONC	2	1	
3-094	3-093	638 N. HUGO	199	8	CONC	4	0	
Total 8":			729					
Total 10":			2,730					
<b>Grand Total:</b>			<b>3,459</b>			<b>81</b>	<b>5</b>	



**OWNER COPY**

**CONTRACT**

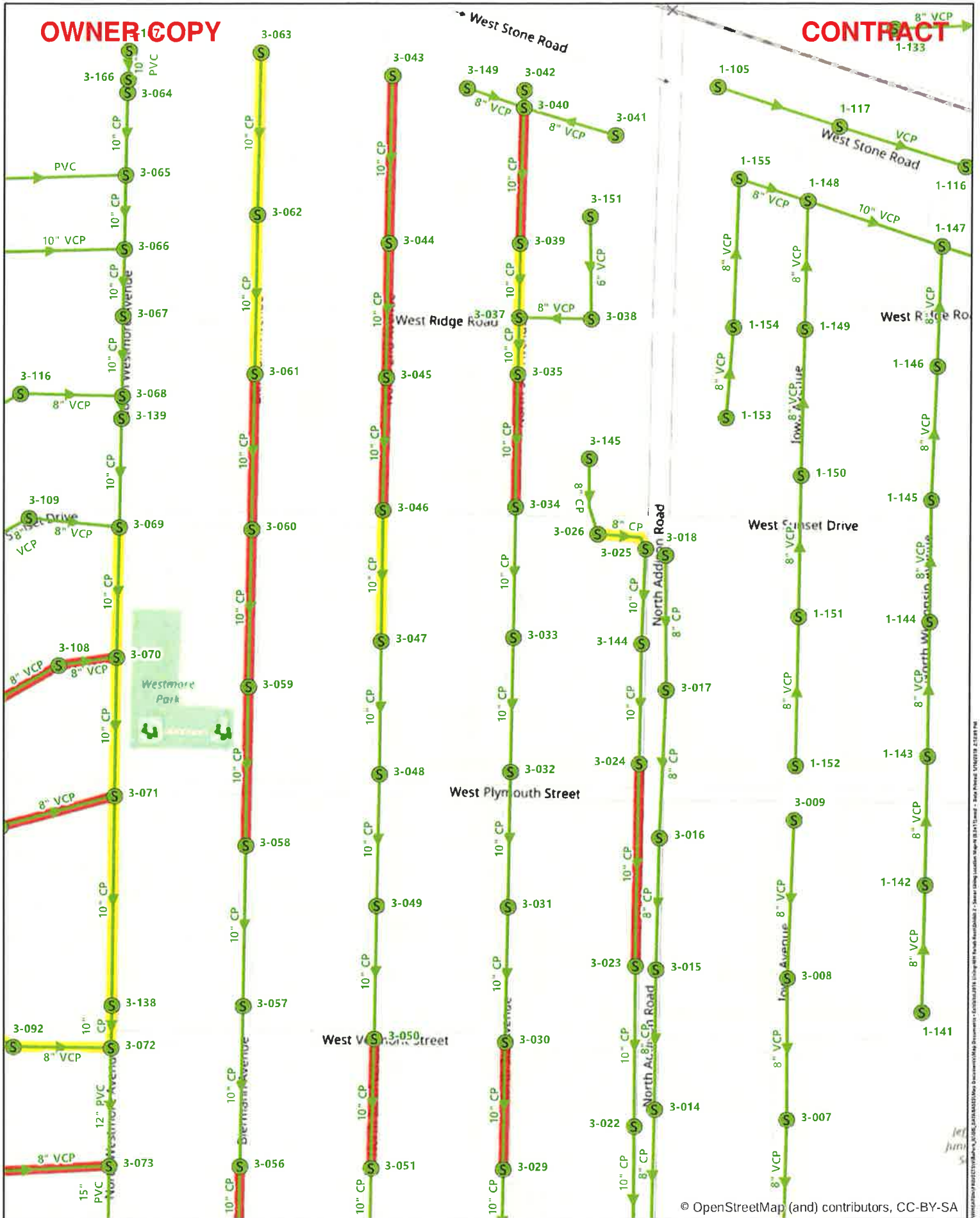

© OpenStreetMap (and) contributors, CC-BY-SA



- Sanitary
- Sanitary
- To be Lined
- To be Lined - Alt



Village of Villa Park, IL  
 2019 Sewer Rehabilitation Program - Exhibit 2  
 Sewer Lining Location Map - N  
 June 2019

I:\Projects\2019 Sewer Rehabilitation Program\GIS\Map\_Sewer\_Lining\_Location\_Map\_N.mxd  
 Date: 6/11/2019 10:58:10 AM  
 User: jh11111





OWNER COPY

CONTRACT

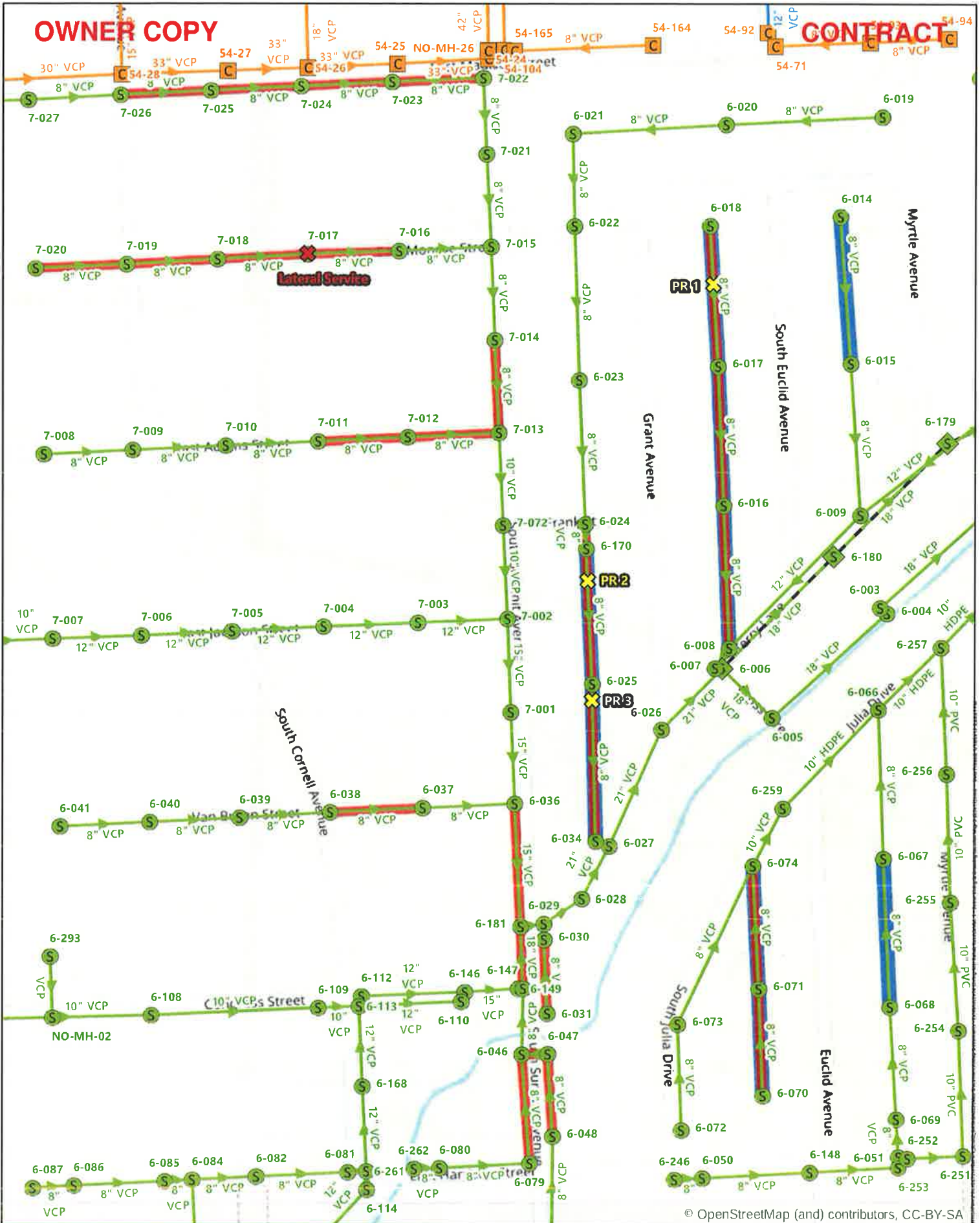

© OpenStreetMap (and) contributors, CC-BY-SA

Sanitary	Separated	Point Repair	To be Lined
Sanitary Overflow	Sanitary	Lateral Service	Grouting Laterals



Village of Villa Park, IL  
 2019 Sewer Rehabilitation Program - Exhibit 5  
 Sewer Lining & Grouting Location Map -  
 June 2019

**OWNER COPY**

**CONTRACT**

**2019 SEWER REHABILITATION PROGRAM  
VILLAGE OF VILLA PARK**

**APPENDIX 4**

**MANHOLE REHABILITATION SCHEDULE  
MANHOLE REHABILITATION LOCATION MAP 1 (EXHIBIT 6)  
MANHOLE REHABILITATION LOCATION MAP 2 (EXHIBIT 7)**

VILLAGE OF VILLA PARK  
 2019 SEWER REHABILITATION PROGRAM  
 MANHOLE REHABILITATION SCHEDULE

Manhole Information						Rehabilitation Recommendations									
Manhole No.	Material	Surface Type	Structure Location	Structure Diameter (in)	Structure Depth (ft)	Replace Cover	Replace Frame And Cover	Seal And Adjust Frame	Uncover and raise buried manhole	Internal Chimney Seal	Cementitious Manhole Sealing	Grout Wall Joints	Curtain Grout Bottom 18 Inches	Full Curtain Grout	Repair Bench And Trough
6-008	Concrete Block	Non-Paved	Grass Easement	48	9.0			X					X		
6-009	Concrete Block	Non-Paved	Grass Easement	48	9.5						X		X		
6-011	Precast Concrete	Non-Paved	Grass Easement	48	5.8					X			X		
6-012	Concrete Block	Non-Paved	Grass Easement	48	4.6		X				X		X		
6-013	Precast Concrete	Non-Paved	Grass Easement	48	13.6	X				X			X		
6-014	MANHOLE NOT FOUND				6.5		X		X		X		X		
6-015	Concrete Block	Non-Paved	Grass Easement	48	4.9	X				X	X	X	X		X
6-016	Concrete Block	Non-Paved	Grass Easement	48	8.8		X				X		X	X	
6-017	Concrete Block	Non-Paved	Grass Easement	48	4.6	X				X	X		X		
6-018	Concrete Block	Non-Paved	Grass Easement	48	6.5						X		X		
6-019	Precast Concrete	Non-Paved	Grass Easement	48	5.8		X				X				
6-020	Precast Concrete	Non-Paved	Grass Easement	48	8.2		X				X	X			
6-021	Precast Concrete	Non-Paved	Grass Easement	48	14.5	X				X	X		X		
6-022	Precast Concrete	Asphalt	Street Pavement	48	12.9					X	X		X		
6-023	Concrete Block	Non-Paved	Grass Easement	48	12.1	X				X	X				
6-024	Precast Concrete	Asphalt	Street Pavement	48	10.2					X		X	X		
6-025	Concrete Block	Non-Paved	Grass Easement	48	7.7		X				X		X	X	
6-034	Concrete Block	Concrete	Sidewalk	48	11.0						X		X		
6-062	Precast Concrete	Asphalt	Other	48	9.6					X		X			
6-063	Concrete Block	Non-Paved	Grass Easement	48	8.5					X	X		X		X
6-064	Concrete Block	Non-Paved	Grass Easement	48	7.0	X					X		X		
6-070	Concrete Block	Non-Paved	Grass Easement	48	8.4					X			X		X
6-071	Concrete Block	Non-Paved	Grass Easement	48	5.8	X				X	X		X		
6-072	Concrete Block	Non-Paved	Grass Easement	48	8.5	X				X	X		X		
6-073	Concrete Block	Non-Paved	Grass Easement	48	6.1					X	X		X		X
6-088	Concrete Block	Non-Paved	Grass Easement	48	23.3		X				X			X	
6-151	Concrete Block	Non-Paved	Grass Easement	48	12.3	X		X			X			X	
6-152	Concrete Block	Non-Paved	Grass Easement	48	10.5		X				X	X	X		
6-170	Concrete Block	Non-Paved	Grass Easement	48	10.5		X				X		X	X	
6-927	Concrete Block	Non-Paved	Grass Easement	48	13.1	X				X	X			X	

OWNER COPY

CONTRACT



© OpenStreetMap (and) contributors, CC-BY-SA



- Sanitary
- Separated
- Manhole Rehabilitation (26)
- Unbury Manhole (1)
- ◆ Sanitary Overflow
- Sanitary



Village of Villa Park  
 2019 Sewer Rehabilitation Program - Exhibit 6  
 Manhole Rehabilitation Location Map 1  
 June 2019

\P\GIS\Projects\2019\_Sewer\_Rehab\Map\_Documents\2019\_Sewer\_Rehab\_Manhole\_Rehab\_Location\_Map\_1\_061519.mxd - Date Plotted: 07/08/2019 10:01:17 AM

**OWNER COPY**

**CONTRACT**



● Sanitary   
 ➔ Sanitary   
 ● Manhole Rehabilitation (4)

© OpenStreetMap (and) contributors, CC-BY-SA



Village of Villa Park  
 2019 Sewer Rehabilitation Program - Exhibit 7  
 Manhole Rehabilitation Location Map 2  
 June 2019

2019 Sewer Rehabilitation Program - Exhibit 7 - Manhole Rehabilitation Location Map (B3411) - Copy.mxd - Date Printed: 1/16/2019 2:24:24 PM

**OWNER COPY**

**CONTRACT**

**2019 SEWER REHABILITATION PROGRAM  
VILLAGE OF VILLA PARK**

**APPENDIX 5**

**ORDINANCE AMENDING THE REQUIREMENTS OF BIDDERS FOR CONSTRUCTION PROJECTS  
IRMA CONTRACTUAL INSURANCE GUIDELINES**

**Ordinance No. 3733****AN ORDINANCE OF THE VILLAGE OF VILLA PARK, DUPAGE COUNTY, ILLINOIS AMENDING THE REQUIREMENTS OF BIDDERS FOR CONSTRUCTION PROJECTS**

**WHEREAS**, the Village of Villa Park (the “*Village*”) is a duly organized and validly existing non home-rule municipality created in accordance with the Constitution of the State of Illinois of 1970 and the laws of the State; and,

**WHEREAS**, section 8-9-1 of the Illinois Municipal Code (65 ILCS 5/8-9-2) allows the Village to require competitive bidding after advertising for bids in the manner prescribed by ordinance; and,

**WHEREAS**, the President and Board of Trustees desire to adopt purchasing procedures to provide for additional requirements of bidders for construction projects to have active apprenticeship and training programs approved and registered with the United States Department of Labor’s Bureau of Apprenticeship and Training and to have bidders show three similar projects they constructed within the last five years.

**NOW, THEREFORE, BE IT ORDAINED** by the President and Board of Trustees of the Village of Villa Park, DuPage County, Illinois, as follows:

**Section 1.** That Section 2-219 of the Villa Park Municipal Code, as amended, be and is hereby amended by placing the existing text as subsection A. and adding a new subsection B. to read as follows:

“B. A responsible bidder for the construction of public works projects shall meet and submit evidence of compliance with the following requirements:

- (1) All applicable laws prerequisite to doing business in the State of Illinois,
- (2) A federal employer tax identification number or social security number,
- (3) Provision of Section 2000(e) of Chapter 21, Title 42 of the United States Code and Federal Executive Order No. 11246 as amended by Executive Order No. 11375 (known as the Equal Opportunity Employer provisions),
- (4) Certificates of insurance indicating the following coverage’s: general liability, worker’s compensation, completed operations, automobile, hazardous occupation and product liability
- (5) Compliance with all provisions of the Illinois Prevailing Wage Act, including wages, medical and hospitalization insurance and retirement for those trades covered in the Act,
- (6) The bidder and all bidder’s sub-contractors must participate in active apprenticeship and training programs approved and registered with the United States Department of Labor’s Bureau of Apprenticeship and Training for each of the trades of work contemplated under the proposed contract,
- (7) All contractors and sub-contractors are required to file certified payrolls as specified in Illinois Pubic Act 94-0515, and follow all provisions of the Employee Classification Act (820 ILCS 185/1 et seq.), and

(8) All bidders must provide three (3) projects of a similar nature constructed in the immediate past five (5) years with the name, address and telephone number of the contact person having knowledge of the project along with three (3) references (name, address, and telephone number) with knowledge of the integrity and business practices of the bidder.”

**Section 2.** This Ordinance shall be in full force and effect upon its passage, approval, and publication as provided by law.

Passed this 11 day of February, 2013.

AYES: ALL

NAYS: Aiello Bulthuis

ABSENT: \_\_\_\_\_

Approved this 11 day of February, 2013.

  
Village President

Attest:  
  
Village Clerk



Published in pamphlet form:

2-11, 2013

**IRMA  
CONTRACTUAL INSURANCE GUIDELINES**

**I. INSURANCE REQUIREMENTS**

Contractor shall procure and maintain, for the duration of the contract, insurance against claims for injuries to persons or damages to property, which may arise from or in connection with the performance of the work hereunder by the Contractor, his agents, representatives, employees or subcontractors.

**MINIMUM SCOPE OF INSURANCE**

Coverage shall be at least as broad as:

- A. Insurance Services Office Commercial General Liability occurrence form CG 0001 with the member named as additional insured, on a form at least as broad as the attached sample endorsement including ISO Additional Insured Endorsement CG 2010 (Exhibit A), CG 2026 (Exhibit B).

**CG2037 - Completed Operations – (Exhibit C)**

**Required if box is checked**  ; and

- B. Owners and Contractors Protective Liability (OCP) policy with the member as insured

**Required if box is checked**  ; and

- C. Insurance Service Office Business Auto Liability coverage form number CA 0001, Symbol 01 "Any Auto."

- D. Workers' Compensation as required by the Workers' Compensation Act of the State of Illinois and Employers' Liability insurance.

**Coverage required for employee exposure to lead, if box is checked**

- E. Builder Risk Property Coverage with member as loss payee

**Required if box is checked** .

- F. Environmental Impairment/Pollution Liability Coverage for pollution incidents as a result of a claim for bodily injury, property damage or remediation costs from an incident at, on or migrating beyond the contracted work site. Coverage shall be extended to Non-Owned Disposal sites resulting from a pollution incident at, on or mitigating beyond the site; and also provide coverage for incidents occurring during transportation of pollutants.

**Required if box is checked** .

**MINIMUM LIMITS OF INSURANCE**

Contractor shall maintain limits no less than the following, **if required under above scope**:

- A. Commercial General Liability: \$1,000,000 combined single limit per occurrence for bodily injury, and property damage and \$1,000,000 per occurrence for personal injury. The general aggregate shall be twice the required occurrence limit. Minimum General Aggregate shall be no less than \$2,000,000 or a project/contract

specific aggregate of \$1,000,000.

- B. Owners and Contractors Protective Liability (OCP): \$1,000,000 combined single limit per occurrence for bodily injury and property damage.
- C. Business Automobile Liability: \$1,000,000 combined single limit per accident for bodily injury and property damage.
- D. Workers' Compensation and Employers' Liability: Workers' Compensation coverage with statutory limits and Employers' Liability limits of \$500,000 per accident.
- E. Builder's Risk: Shall insure against "All Risk" of physical damage, including water damage (flood and hydrostatic pressure not excluded), on a completed replacement cost basis.
- F. Environmental Impairment/Pollution Liability: \$1,000,000 combined single limit per occurrence for bodily injury, property damage and remediation costs.

#### **DEDUCTIBLES AND SELF-INSURED RETENTIONS**

Any deductibles or self-insured retentions must be declared to and approved by the member. At the option of the member, either: the insurer shall reduce or eliminate such deductibles or self-insured retentions as respects the member, its officials, employees, agents and volunteers; or the Contractor shall procure a bond guaranteeing payment of losses and related investigation, claim administration and defense expenses.

#### **OTHER INSURANCE PROVISIONS**

The policies are to contain, or be endorsed to contain, the following provisions:

##### **A. General Liability and Automobile Liability Coverages**

1. The member, its officials, agents, employees and volunteers are to be covered as additional insureds as respects: liability arising out of the Contractor's work, including activities performed by or on behalf of the Contractor; products and completed operations of the Contractor; premises owned, leased or used by the Contractor; or automobiles owned, leased, hired or borrowed by the Contractor. The coverage shall contain no special limitations on the scope of protection afforded to the member, its officials, agents, employees and volunteers.
2. The Contractor's insurance coverage shall be primary as respects the member, its officials, employees, agents and volunteers. Any insurance or self-insurance maintained by the member, its officials, agents, employees and volunteers shall be excess of Contractor's insurance and shall not contribute with it.
3. Any failure to comply with reporting provisions of the policies shall not affect coverage provided to the member, its officials, employees, agents and volunteers.
4. The Contractor's insurance shall contain a Severability of Interests/Cross Liability clause or language stating that Contractor's insurance shall apply

separately to each insured against whom claim is made or suit is brought, except with respect to the limits of the insurer's liability.

- 5. If any commercial general liability insurance is being provided under an excess or umbrella liability policy that does not "follow form," then the Contractor shall be required to name the member, its officials, employees, agents and volunteers as additional insureds.
- 6. All general liability coverages shall be provided on an occurrence policy form. Claims-made general liability policies will not be accepted.
- 7. The contractor and all subcontractors hereby agree to waive any limitation as to the amount of contribution recoverable against them by member. This specifically includes any limitation imposed by any state statute, regulation, or case law including any Workers' Compensation Act provision that applies a limitation to the amount recoverable in contribution such as Kotecki v. Cyclops Welding.

**B. Workers' Compensation and Employers' Liability Coverage**

The insurer shall agree to waive all rights of subrogation against the member, its officials, employees, agents and volunteers for losses arising from work performed by Contractor for the municipality.

- 1. NCCI Alternate Employer Endorsement (WC 000301) in place to insure that workers' compensation coverage applies under contractor's coverage rather than member's if the member is borrowing, leasing or in day to day control of contractors employee.

**Required if box is checked .**

**C. Professional Liability (Required if box is checked )**

- 1. Professional liability insurance with limits not less than \$1,000,00 each claim with respect to negligent acts, errors and omissions in connection with professional services to be provided under the contract, with a deductible not-to-exceed \$50,000 without prior written approval.
- 2. If the policy is written on a claims-made form, the retroactive date must be equal to or preceding the effective date of the contract. In the event the policy is cancelled, non-renewed or switched to an occurrence form, the Contractor shall be required to purchase supplemental extending reporting period coverage for a period of not less than three (3) years.
- 3. Provide a certified copy of actual policy for review.
- 4. Recommended Required Coverage (architect, engineer, surveyor, consultant): Professional liability insurance that provides indemnification and defense for injury or damage arising out of acts, errors, or omissions in providing the following professional services, but not limited to the following:
  - a. Preparing, approving or failure to prepare or approve maps, drawings, opinions, report, surveys, change orders, designs or specifications;
  - b. Providing direction, instruction, supervision, inspection, engineering

services or failing to provide them, if that is the primary cause of injury or damage.

**D. All Coverages**

Each insurance policy required shall have the member expressly endorsed onto the policy as a Cancellation Notice Recipient. Should any of the policies be cancelled before the expiration date thereof, notice will be delivered in accordance with the policy provisions.

**ACCEPTABILITY OF INSURERS**

Insurance is to be placed with insurers with a Best's rating of no less than A-, VII and licensed to do business in the State of Illinois.

**VERIFICATION OF COVERAGE**

Contractor shall furnish the member with certificates of insurance naming the member, its officials, employees, agents and volunteers as additional insureds (Exhibit D), and with original endorsements affecting coverage required by this clause. The certificates and endorsements for each insurance policy are to be signed by a person authorized by that insurer to bind coverage on its behalf. The certificates and endorsements are to be received and approved by the member before any work commences. The following additional insured endorsements may be utilized: ISO Additional Insured Endorsements CG 2010 (Exhibit A) or CG 2026 (Exhibit B), and CG 2037 (Exhibit C) – Completed Operations, where required. The member reserves the right to request full certified copies of the insurance policies and endorsements.

**SUBCONTRACTORS**

Contractor shall include all subcontractors as insureds under its policies or shall furnish separate certificates and endorsements for each subcontractor. All coverages for subcontractors shall be subject to all of the requirements stated herein.

**ASSUMPTION OF LIABILITY**

The contractor assumes liability for all injury to or death of any person or persons including employees of the contractor, any sub-contractor, any supplier or any other person and assumes liability for all damage to property sustained by any person or persons occasioned by or in any way arising out of any work performed pursuant to this agreement.

**II. INDEMNITY/HOLD HARMLESS PROVISION**

To the fullest extent permitted by law, the Contractor hereby agrees to defend, indemnify and hold harmless the member, its officials, employees and agents against all injuries, deaths, loss, damages, claims, patent claims, suits, liabilities, judgments, cost and expenses, which may in anywise accrue against the member, its officials, agents and employees, arising in whole or in part or in consequence of the performance of this work by the Contractor, its employees, or subcontractors, or which may in anywise result therefore, except that arising out of the sole legal cause of the member, its employees or agents, the Contractor shall, at its own expense, appear, defend and pay all charges of attorneys and all costs and other expenses arising therefore or incurred in connections

therewith, and, if any judgment shall be rendered against the member, its officials, employees and agents, in any such action, the Contractor shall, at its own expense, satisfy and discharge the same.

Contractor expressly understands and agrees that any performance bond or insurance policies required by this contract, or otherwise provided by the Contractor, shall in no way limit the responsibility to indemnify, keep and save harmless and defend the member, its officials, employees and agents as herein provided.

The Contractor further agrees that to the extent that money is due the Contractor by virtue of this contract as shall be considered necessary in the judgment of the member, may be retained by the member to protect itself against said loss until such claims, suits, or judgments shall have been settled or discharged and/or evidence to that effect shall have been furnished to the satisfaction of the member.

### **III. SAFETY/LOSS PREVENTION**

#### **Safety/Loss Prevention Program Requirements**

- Successful bidder will provide written confirmation that a safety/loss prevention program was in place at least 90 days prior to submitting the bid proposal.
- Evidence of completed employee safety training can be provided.

#### **Regulatory Requirements**

- Successful bidder must comply with all applicable laws, regulations, and rules promulgated by any Federal, State, County, Municipal and/or other governmental unit or regulatory body now in effect or which may be in effect during the performance of the work. Included within the scope of the laws, regulations, and rules referred to in this paragraph but in no way to operate as a limitation, are Occupational Safety & Health Act (OSHA), Illinois Department of Labor (IDOL), Department of Transportation, all forms of traffic regulations, public utility, Intrastate and Interstate Commerce Commission regulations, Workers' Compensation Laws, Prevailing Wage Laws, the Social Security Act of the Federal Government and any of its titles, the Illinois Department of Human Rights, Human Rights Commission, or EEOC statutory provisions and rules and regulations.
- Evidence of specific regulatory compliance will be provided by bidder, if required by owner.

EXHIBIT A

POLICY NUMBER:

COMMERCIAL GENERAL LIABILITY  
CG 20 10 07 04

THIS ENDORSEMENT CHANGES THE POLICY. PLEASE READ IT CAREFULLY.

**ADDITIONAL INSURED – OWNERS, LESSEES OR  
CONTRACTORS – SCHEDULED PERSON OR  
ORGANIZATION**

This endorsement modifies insurance provided under the following:

COMMERCIAL GENERAL LIABILITY COVERAGE PART

**SCHEDULE**

Name Of Additional Insured Person(s) Or Organization(s):	Location(s) Of Covered Operations
<p>Information required to complete this Schedule, if not shown above, will be shown in the Declarations.</p>	

**A. Section II – Who Is An Insured** is amended to include as an additional insured the person(s) or organization(s) shown in the Schedule, but only with respect to liability for "bodily injury", "property damage" or "personal and advertising injury" caused, in whole or in part, by:

1. Your acts or omissions; or
2. The acts or omissions of those acting on your behalf;

in the performance of your ongoing operations for the additional insured(s) at the location(s) designated above.

**B.** With respect to the insurance afforded to these additional insureds, the following additional exclusions apply:

This insurance does not apply to "bodily injury" or "property damage" occurring after:

1. All work, including materials, parts or equipment furnished in connection with such work, on the project (other than service, maintenance or repairs) to be performed by or on behalf of the additional insured(s) at the location of the covered operations has been completed; or
2. That portion of "your work" out of which the injury or damage arises has been put to its intended use by any person or organization other than another contractor or subcontractor engaged in performing operations for a principal as a part of the same project.

EXHIBIT B

POLICY NUMBER:

COMMERCIAL GENERAL LIABILITY  
CG 20 26 07 04

THIS ENDORSEMENT CHANGES THE POLICY. PLEASE READ IT CAREFULLY.

**ADDITIONAL INSURED – DESIGNATED  
PERSON OR ORGANIZATION**

This endorsement modifies insurance provided under the following:

COMMERCIAL GENERAL LIABILITY COVERAGE PART

**SCHEDULE**

Name Of Additional Insured Person(s) Or Organization(s)
<p>EXAMPLE</p>

Information required to complete this Schedule, if not shown above, will be shown in the Declarations.

**Section II – Who Is An Insured** is amended to include as an additional insured the person(s) or organization(s) shown in the Schedule, but only with respect to liability for "bodily injury", "property damage" or "personal and advertising injury" caused, in whole or in part, by your acts or omissions or the acts or omissions of those acting on your behalf:

- A. In the performance of your ongoing operations; or
- B. In connection with your premises owned by or rented to you.

**EXHIBIT**

**C**

POLICY NUMBER:

**COMMERCIAL GENERAL LIABILITY**  
CG 20 37 07 04

**THIS ENDORSEMENT CHANGES THE POLICY. PLEASE READ IT CAREFULLY.**

**ADDITIONAL INSURED – OWNERS, LESSEES OR  
CONTRACTORS – COMPLETED OPERATIONS**

This endorsement modifies Insurance provided under the following:

COMMERCIAL GENERAL LIABILITY COVERAGE PART

**SCHEDULE**

Name Of Additional Insured Person(s) Or Organization(s):	Location And Description Of Completed Operations
<p style="text-align: center; font-size: 2em; opacity: 0.5; transform: rotate(-45deg);">SAMPLE</p>	
	<p>Information required to complete this Schedule, if not shown above, will be shown in the Declarations.</p>

**Section II – Who Is An Insured** is amended to include as an additional insured the person(s) or organization(s) shown in the Schedule, but only with respect to liability for "bodily injury" or "property damage" caused, in whole or in part, by "your work" at the location designated and described in the schedule of this endorsement performed for that additional insured and included in the "products-completed operations hazard".

Exhibit D (Example)



**CERTIFICATE OF LIABILITY INSURANCE**

DATE (MM/DD/YYYY)

THIS CERTIFICATE IS ISSUED AS A MATTER OF INFORMATION ONLY AND CONFERS NO RIGHTS UPON THE CERTIFICATE HOLDER. THIS CERTIFICATE DOES NOT AFFIRMATIVELY OR NEGATIVELY AMEND, EXTEND OR ALTER THE COVERAGE AFFORDED BY THE POLICIES BELOW. THIS CERTIFICATE OF INSURANCE DOES NOT CONSTITUTE A CONTRACT BETWEEN THE ISSUING INSURER(S), AUTHORIZED REPRESENTATIVE OR PRODUCER, AND THE CERTIFICATE HOLDER.

IMPORTANT: If the certificate holder is an ADDITIONAL INSURED, the policy(ies) must be endorsed. If SUBROGATION IS WAIVED, subject to the terms and conditions of the policy, certain policies may require an endorsement. A statement on this certificate does not confer rights to the certificate holder in lieu of such endorsement(s).

PRODUCER  Name of Insurance Broker	CONTACT NAME: <b>Producer/Ins. Broker Contact Info.</b>	
	PHONE (A/C, No, Ext): _____ FAX (A/C, No): _____ E-MAIL ADDRESS: _____	
INSURED  Name of Contractor	INSURER(S) AFFORDING COVERAGE	NAIC #
	INSURER A: Name of Insurance Company	Completed
	INSURER B: Name of Insurance Company	Completed
	INSURER C:	
	INSURER D:	
	INSURER E:	

COVERAGES CERTIFICATE NUMBER: REVISION NUMBER:

THIS IS TO CERTIFY THAT THE POLICIES OF INSURANCE LISTED BELOW HAVE BEEN ISSUED TO THE INSURED NAMED ABOVE FOR THE POLICY PERIOD INDICATED. NOTWITHSTANDING ANY REQUIREMENT, TERM OR CONDITION OF ANY CONTRACT OR OTHER DOCUMENT WITH RESPECT TO WHICH THIS CERTIFICATE MAY BE ISSUED OR MAY PERTAIN, THE INSURANCE AFFORDED BY THE POLICIES DESCRIBED HEREIN IS SUBJECT TO ALL THE TERMS, EXCLUSIONS AND CONDITIONS OF SUCH POLICIES. LIMITS SHOWN MAY HAVE BEEN REDUCED BY PAID CLAIMS.

INSR LTR	TYPE OF INSURANCE	ADDL INSR	SUBR WVD	POLICY NUMBER	POLICY EFF (MM/DD/YYYY)	POLICY EXP (MM/DD/YYYY)	LIMITS
A	<b>GENERAL LIABILITY</b> <input checked="" type="checkbox"/> COMMERCIAL GENERAL LIABILITY <input type="checkbox"/> CLAIMS-MADE <input type="checkbox"/> OCCUR Owners & Cont. Prot. (OCP) if requested GEN'L AGGREGATE LIMIT APPLIES PER: <input checked="" type="checkbox"/> POLICY <input type="checkbox"/> PRO-JECT <input type="checkbox"/> LOC	Y	Y	Policy Number Inserted	Policy Start Date	Policy Start Date	EACH OCCURRENCE \$ 1,000,000 DAMAGE TO RENTED PREMISES (Ea occurrence) \$ 50,000 MED EXP (Any one person) \$ 5,000 PERSONAL & ADV INJURY \$ 1,000,000 GENERAL AGGREGATE \$ 2,000,000 PRODUCTS - COMP/OP AGG \$ 1,000,000
A	<b>AUTOMOBILE LIABILITY</b> <input checked="" type="checkbox"/> ANY AUTO ALL OWNED AUTOS <input type="checkbox"/> SCHEDULED AUTOS HIRED AUTOS <input type="checkbox"/> NON-OWNED AUTOS			Policy Number Inserted	Policy Start Date	Policy Start Date	COMBINED SINGLE LIMIT (Ea accident) \$ 1,000,000 BODILY INJURY (Per person) \$ BODILY INJURY (Per accident) \$ PROPERTY DAMAGE (Per accident) \$
A	<input checked="" type="checkbox"/> UMBRELLA LIAB <input checked="" type="checkbox"/> OCCUR <input type="checkbox"/> EXCESS LIAB <input type="checkbox"/> CLAIMS-MADE DED RETENTION \$	Y	Y	Policy Number Inserted	Policy Start Date	Policy Start Date	EACH OCCURRENCE \$ Per Request AGGREGATE \$ Per Request
B	<b>WORKERS COMPENSATION AND EMPLOYERS' LIABILITY</b> ANY PROPRIETOR/PARTNER/EXECUTIVE OFFICER/MEMBER EXCLUDED? (Mandatory in NH) If yes, describe under DESCRIPTION OF OPERATIONS below	Y/N	N/A	Policy Number Inserted	Policy Start Date	Policy Start Date	<input checked="" type="checkbox"/> WC STATUTORY LIMITS <input type="checkbox"/> OTH-ER E.L. EACH ACCIDENT \$ 500,000 E.L. DISEASE - EA EMPLOYEE \$ 500,000 E.L. DISEASE - POLICY LIMIT \$ 500,000
	Professional Liability (other specialty coverages as requested)			Policy Number Inserted	Policy Start Date	Policy start Date	\$1,000,000 per occurrence or as requested

DESCRIPTION OF OPERATIONS / LOCATIONS / VEHICLES (Attach ACORD 101, Additional Remarks Schedule, if more space is required)  
 List project number, location and description.  
 No additional endorsements limit coverage to additional insured beyond terms of actual additional insured endorsement (CG 2010 or CG 2026). Coverage to additional insured is primary. Additional insured: Member, its officials, employees, agents and volunteers.  
 \* Member named as cancellation notice recipient.

CERTIFICATE HOLDER  Name of Member	CANCELLATION  SHOULD ANY OF THE ABOVE DESCRIBED POLICIES BE CANCELLED BEFORE THE EXPIRATION DATE THEREOF, NOTICE WILL BE DELIVERED IN ACCORDANCE WITH THE POLICY PROVISIONS. *
	AUTHORIZED REPRESENTATIVE  Signature of authorized insurance company representative

© 1988-2010 ACORD CORPORATION. All rights reserved.

**OWNER COPY**

**CONTRACT**

**2019 SEWER REHABILITATION PROGRAM  
VILLAGE OF VILLA PARK**

**APPENDIX 6**

**IDOT STANDARD DETAILS**

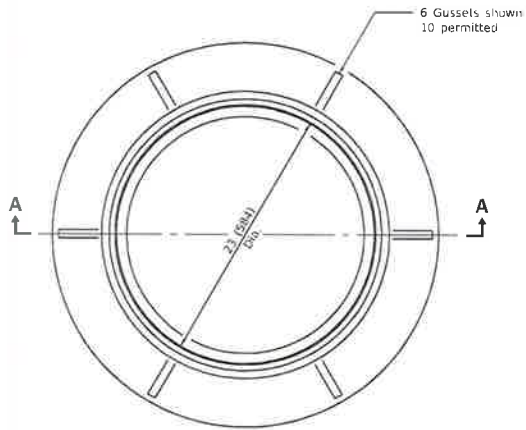

**CAST FRAME**

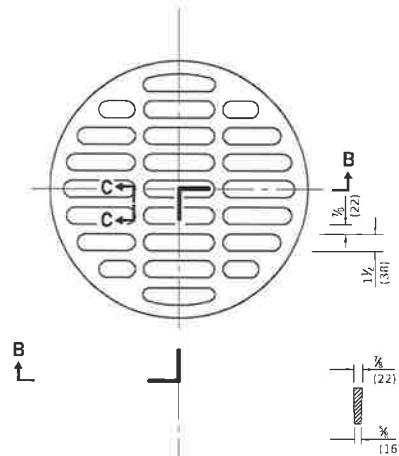

**SECTION C-C**

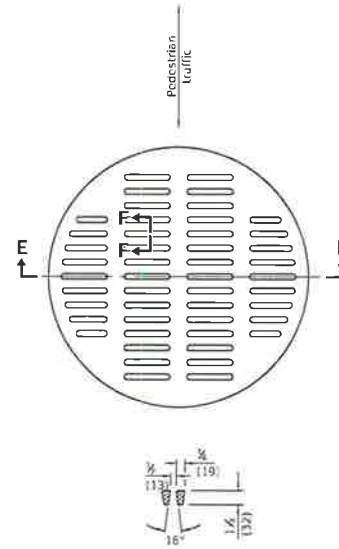

**SECTION F-F**

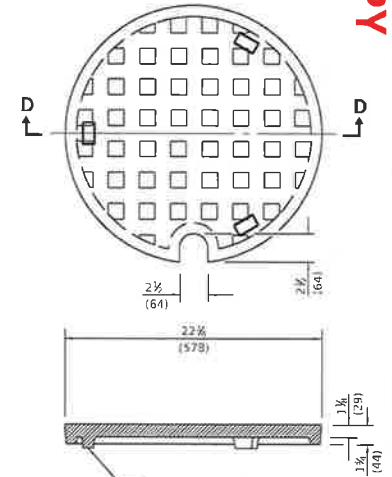

**SECTION D-D**

**CAST CLOSED LID**  
Gray Iron Lid

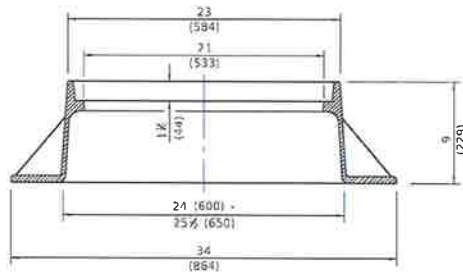

**SECTION A-A**  
Gray Iron

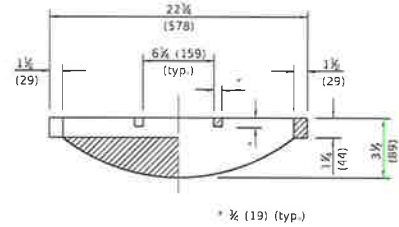

**SECTION B-B**

**CAST OPEN LID**

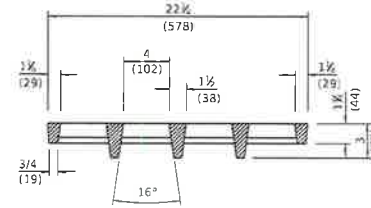

**SECTION E-E**

**ADA COMPLIANT  
CAST OPEN LID**

All dimensions are in inches (millimeters) unless otherwise shown.

Illinois Department of Transportation

APPROVED: *Michael Beard* JULY 1, 2015  
ENGINEER OF POLICY AND PROCEDURES

APPROVED: *[Signature]* JULY 1, 2015  
ENGINEER OF DESIGN AND ENVIRONMENT

DATE	REVISIONS
1-1-15	Revised dimensioning of frame. Added ADA compliant open lid.
1-1-09	Switched units to English (metric).

**FRAME AND LIDS  
TYPE 1**

**STANDARD 604001-04**

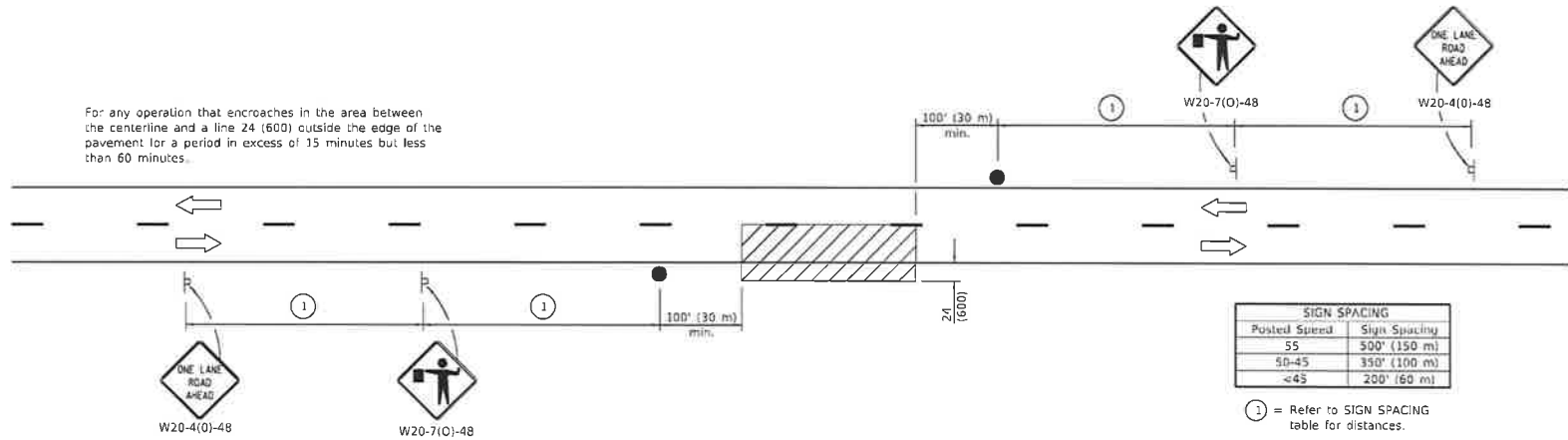
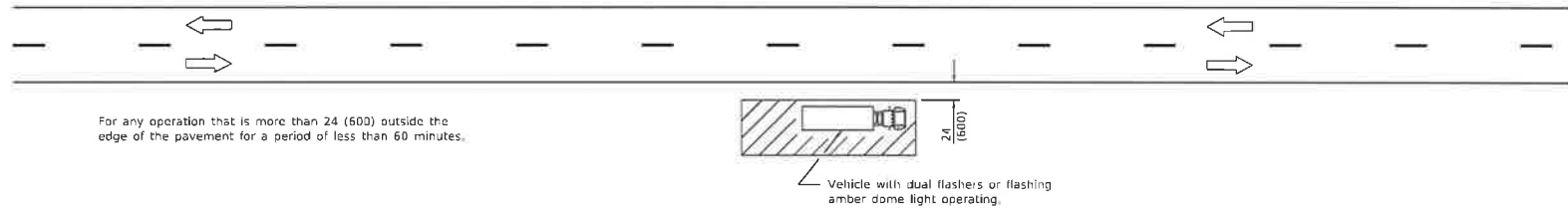
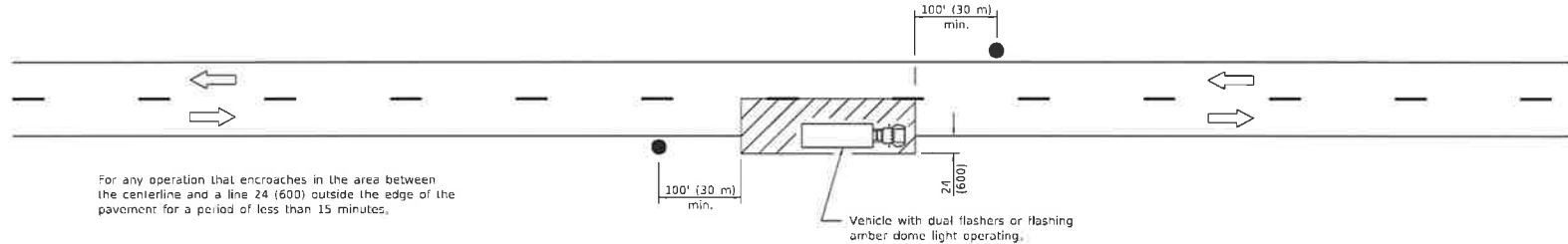

**TYPICAL APPLICATIONS**

- Marking patches
- Field survey
- String line
- Utility operations
- Cleaning up debris on pavement

**SYMBOLS**

- Work area
- Sign on portable or permanent support
- Flagger with traffic control sign

All dimensions are in inches (millimeters) unless otherwise shown.

Illinois Department of Transportation

PASSED: *[Signature]* 2011  
ENGINEER OF SAFETY ENGINEERING

APPROVED: *[Signature]* 2011  
ENGINEER OF DESIGN AND ENVIRONMENT

DATE: 1/11/11

DATE	REVISIONS
1-1-11	Revised 'flagger sign.
1-1-09	Switched units to English (metric).

**LANE CLOSURE, 2L, 2W, SHORT TIME OPERATIONS**

STANDARD 701301-04

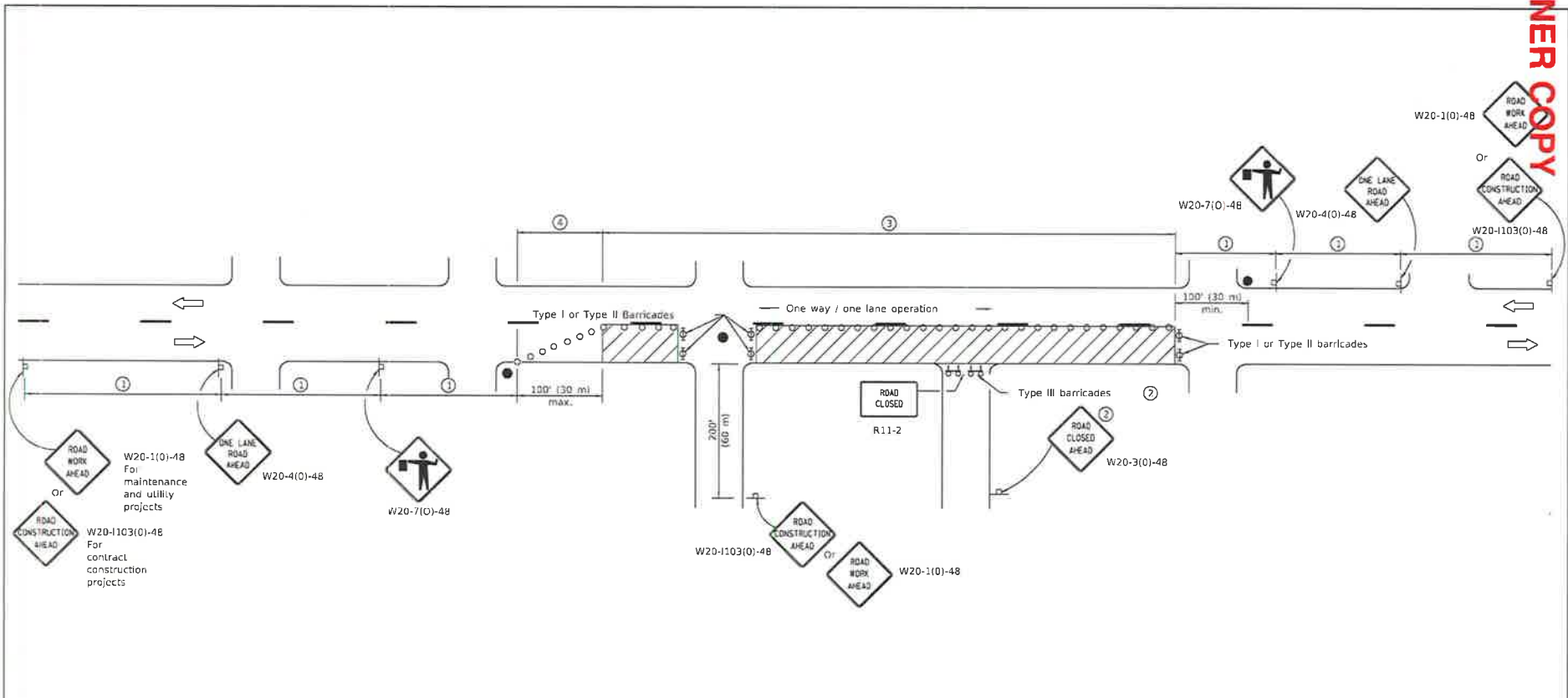

SIGN SPACING	
Posted Speed	Sign Spacing
55	500' (150 m)
50-45	350' (100 m)
<45	200' (60 m)

**SYMBOLS**

- Work area
- Cone, drum or barricade (not required for moving operations)
- Sign on portable or permanent support
- Flagger with traffic control sign
- Barricade or drum with flashing light
- Type III barricade with flashing lights

- ① Refer to SIGN SPACING TABLE for distances.
- ② For approved sideroad closures.
- ③ Cones at 25' (8 m) centers for 250' (75 m). Additional cones may be placed at 50' (15 m) centers. When drums or Type I or Type II barricades are used, the interval between devices may be doubled.
- ④ Cones, drums or barricades at 20' (6 m) centers.

**GENERAL NOTES**

This Standard is used where at any time, day or night, any vehicle, equipment, workers or their activities encroach on the pavement requiring the closure of one traffic lane in an urban area.

All dimensions are in inches (millimeters) unless otherwise shown.

Illinois Department of Transportation

PASSED: \_\_\_\_\_ 2011

ENGINEER OF SAFETY ENGINEERING \_\_\_\_\_ 2011

APPROVED: \_\_\_\_\_ 2011

ENGINEER OF DESIGN AND ENVIRONMENT \_\_\_\_\_

DATE	REVISIONS
1-1-11	Revised flagger sign.
1-1-09	Switched units to English (metric).
	Corrected sign No.'s

**URBAN LANE CLOSURE,  
2L, 2W, UNDIVIDED**

**STANDARD 701501-06**

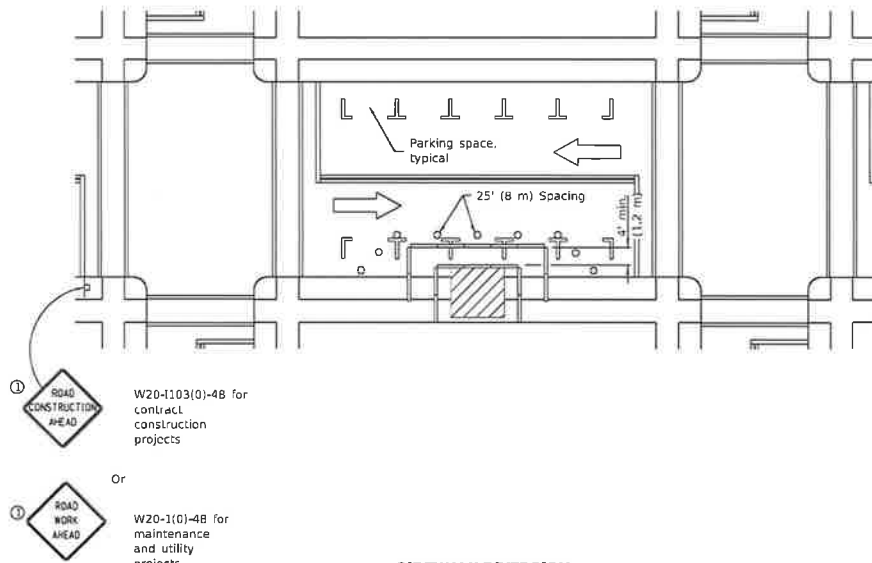

① Omit whenever duplicated by road work traffic control.

**SIDEWALK DIVERSION**

**GENERAL NOTES**

This Standard is used where, at any time, pedestrian traffic must be rerouted due to work being performed.

This Standard must be used in conjunction with other Traffic Control & Protection Standards when roadway traffic is affected.

Temporary facilities shall be detectable and accessible.

The temporary pedestrian facilities shall be provided on the same side of the closed facilities whenever possible.

The SIDEWALK CLOSED / USE OTHER SIDE sign shall be placed at the nearest crosswalk or intersection to each end of the closure. Where the closure occurs at a corner, the signs shall be erected on the corners across the street from the closure. The SIDEWALK CLOSED signs shall be used at the ends of the actual closures.

Type III barricades and R11-2-4830 signs shall be positioned as shown in "ROAD CLOSED TO ALL TRAFFIC" detail on Standard 701901.

All dimensions are in inches (millimeters) unless otherwise shown.

- SYMBOLS**
- Work area
  - Sign on portable or permanent support
  - Barricade or drum
  - Cone, drum or barricade
  - Type III barricade
  - Detectable pedestrian channelizing barricade

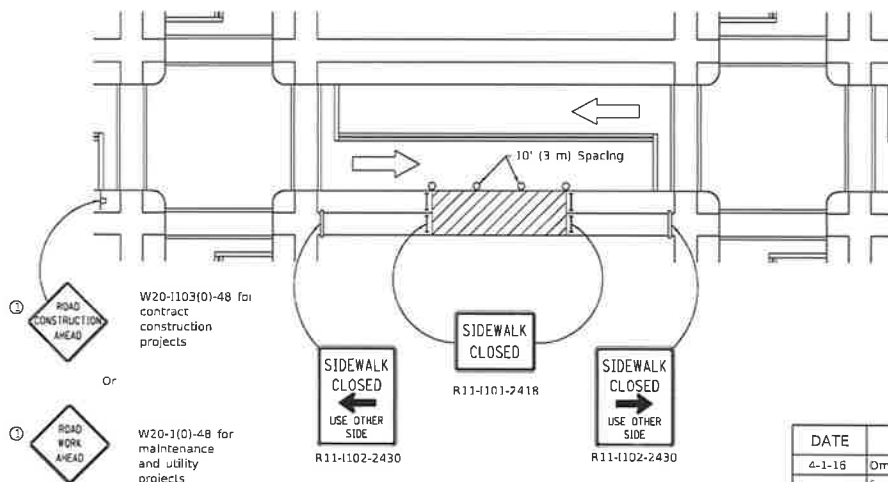

**SIDEWALK CLOSURE**

DATE	REVISIONS
4-1-16	Omitted orange safety fence from standard as this is covered in the std. spec.
1-1-12	Added SIDEWALK DIVERSION. Modified appearance of plan views. Renamed Std.

**SIDEWALK, CORNER OR CROSSWALK CLOSURE**

(Sheet 1 of 2)

**STANDARD 701801-06**

Illinois Department of Transportation

ISSUED: *[Signature]* APR 1, 2016  
ENGINEER OF SAFETY ENGINEERING

APPROVED: *[Signature]* APR 1, 2016  
ENGINEER OF DESIGN AND ENVIRONMENT

16-11-06(06)

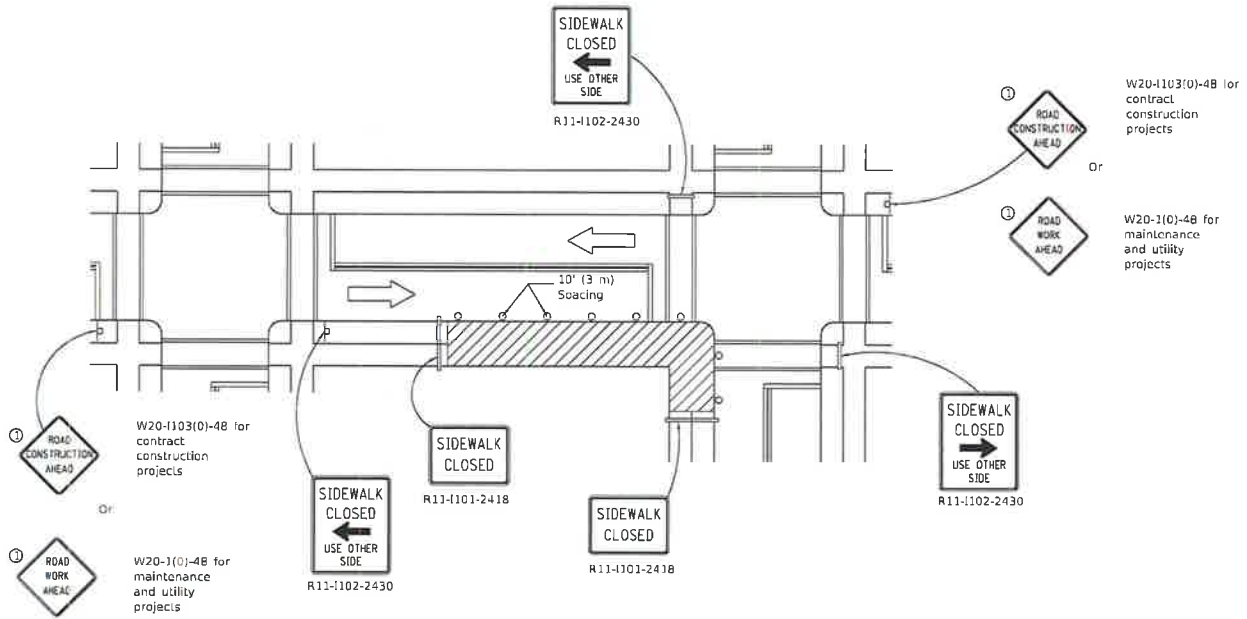

**CORNER CLOSURE**

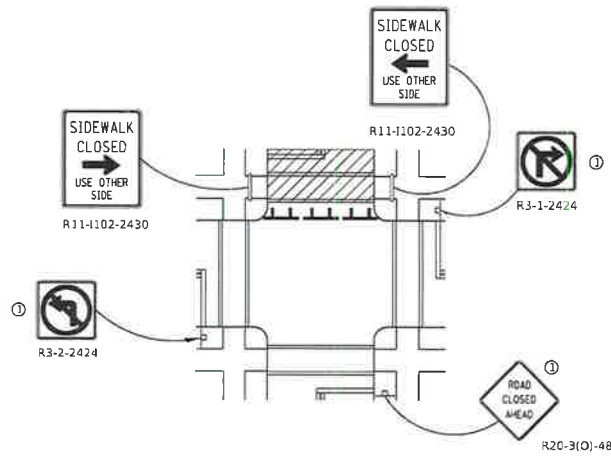

**CROSSWALK CLOSURE**

Illinois Department of Transportation

PASSED:                      APR 2, 2016

ENGINEER OF SAFETY ENGINEERING:                     

APPROVED BY:                      2016

ENGINEER OF DESIGN AND ENVIRONMENT:                     

ST 111 (1/10/09)

**SIDEWALK, CORNER OR CROSSWALK CLOSURE**

(Sheet 2 of 2)

**STANDARD 701801-06**

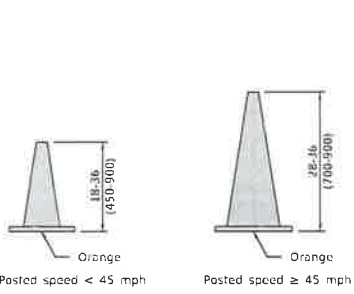

**CONE FOR DAYTIME**

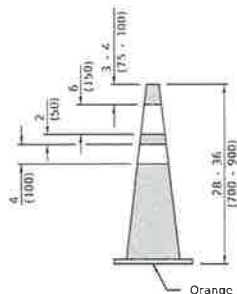

**REFLECTORIZED CONE FOR NIGHTTIME**

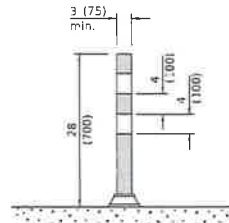

**TUBULAR MARKER**

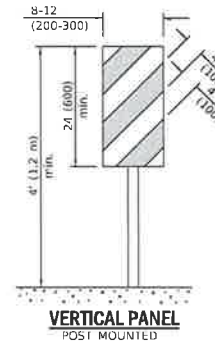

**VERTICAL PANEL**

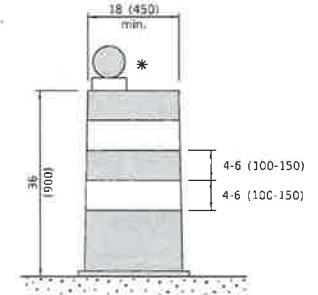

**DRUM**

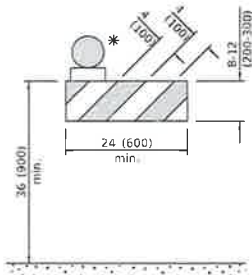

**TYPE I BARRICADE**

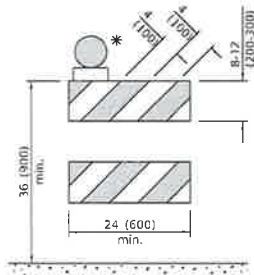

**TYPE II BARRICADE**

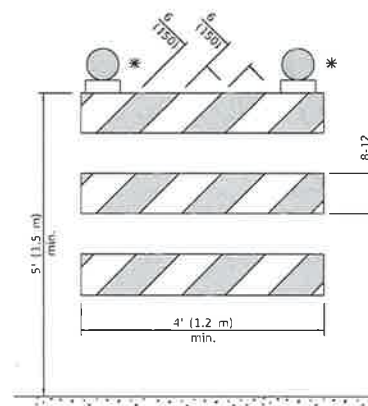

**TYPE III BARRICADE**

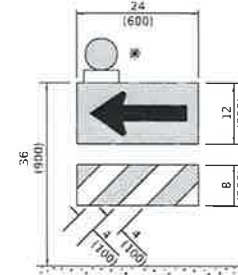

**DIRECTION INDICATOR BARRICADE**

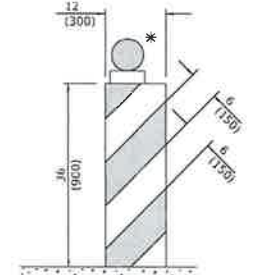

**VERTICAL BARRICADE**

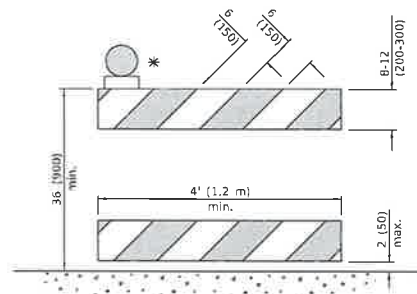

**DETECTABLE PEDESTRIAN CHANNELIZING BARRICADE**

\* Warning lights (if required)

**GENERAL NOTES**

All heights shown shall be measured above the pavement surface.

All dimensions are in inches (millimeters) unless otherwise shown.

Illinois Department of Transportation

PAK/PO  
 [Signature]  
 ENGINEER OF OPERATIONS  
 APPROVED [Signature]  
 ENGINEER OF DESIGN AND ENVIRONMENT

DATE	REVISIONS
1-1-18	Revised END WORK ZONE
	SPEED LIMIT sign from orange to white background.
1-1-17	Changed FLEXIBLE DELINEATOR to TUBULAR MARKER.

**TRAFFIC CONTROL DEVICES**

(Sheet 3 of 3)

**STANDARD 701901-07**

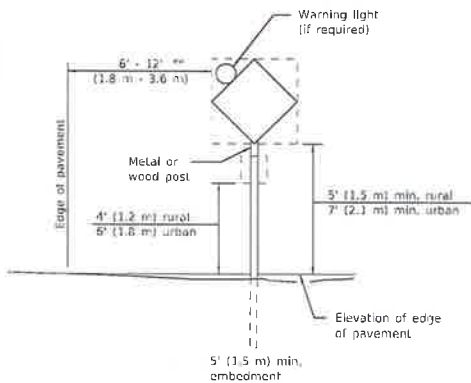

**POST MOUNTED SIGNS**

When curb or paved shoulder are present this dimension shall be 24 (600) to the face of curb or 6' (1.8 m) to the outside edge of the paved shoulder.

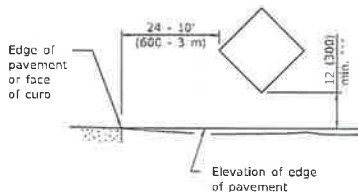

**SIGNS ON TEMPORARY SUPPORTS**

When work operations exceed four days, this dimension shall be 5' (1.5 m) min. If located behind other devices, the height shall be sufficient to be seen completely above the devices.

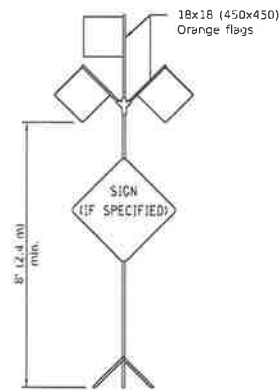

**HIGH LEVEL WARNING DEVICE**

ROAD CONSTRUCTION NEXT X MILES G20-1104(0)-6036	END CONSTRUCTION G20-1105(0)-6024
--	--------------------------------------

This signing is required for all projects 2 miles (3200 m) or more in length.  
ROAD CONSTRUCTION NEXT X MILES sign shall be placed 500' (150 m) in advance of project limits.  
END CONSTRUCTION sign shall be erected at the end of the job unless another job is within 2 miles (3200 m).  
Dual sign displays shall be utilized on multi-lane highways.

**WORK LIMIT SIGNING**

WORK ZONE W21-1115(0)-3618
SPEED LIMIT R2-1-3648 <b>XX</b>
PHOTO ENFORCED R10-1108p-3618
\$XXX FINE MINIMUM R2-1106p-3618

Sign assembly as shown on Standards or as allowed by District Operations.

END WORK ZONE SPEED LIMIT G20-1103-6036
--

This sign shall be used when the above sign assembly is used.

**HIGHWAY CONSTRUCTION SPEED ZONE SIGNS**

R10-1108p shall only be used along roadways under the jurisdiction of the State.



W12-1103-1848

**WIDTH RESTRICTION SIGN**

XX'-XX" width and X miles are variable.

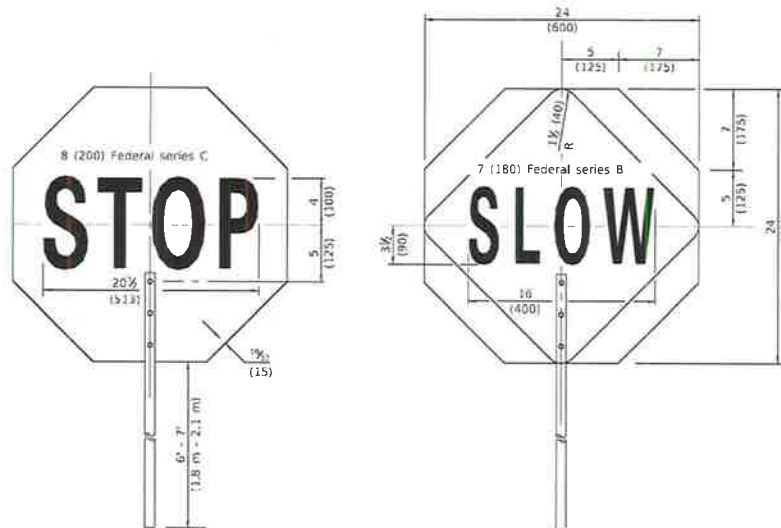

FRONT SIDE

REVERSE SIDE

**FLAGGER TRAFFIC CONTROL SIGN**

Illinois Department of Transportation

ISSUED: January 3, 2010

ENGINEER OF OPERATIONS: *Tom Blum*

APPROVED: *Thomas A. Blum*

ENGINEER OF DESIGN AND ENVIRONMENT

**TRAFFIC CONTROL DEVICES**

(Sheet 2 of 3)

STANDARD 701901-07

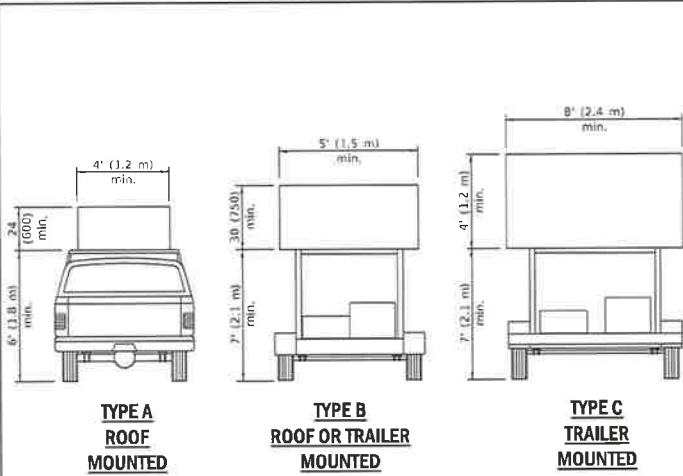

ARROW BOARDS

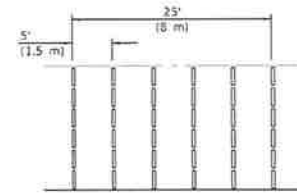
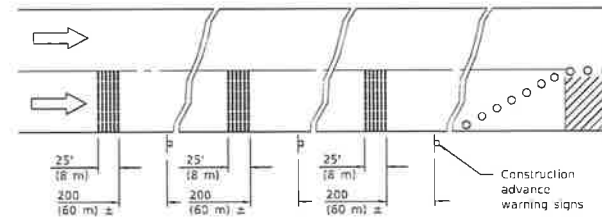
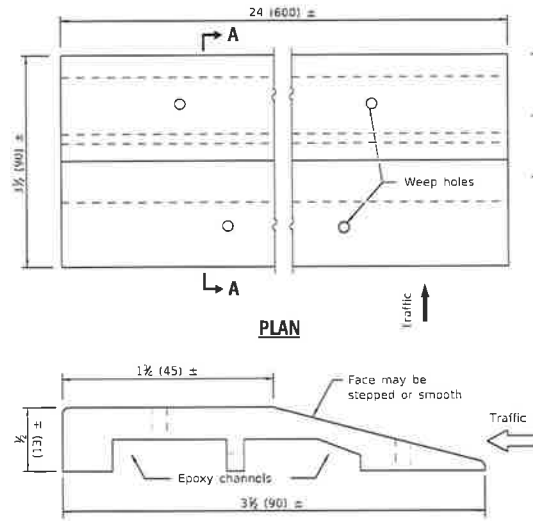

TEMPORARY RUMBLE STRIPS

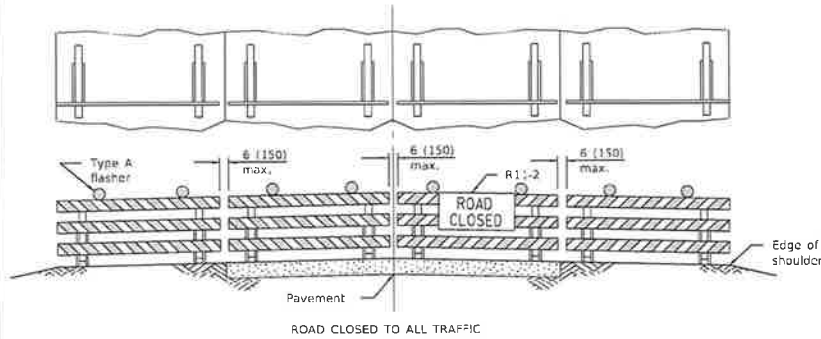

Reflectorized striping may be omitted on the back side of the barricades. If a Type III barricade with an attached sign panel which meets NCHRP 350 is not available, the sign may be mounted on an NCHRP 350 temporary sign support directly in front of the barricade.

**TYPICAL APPLICATIONS OF  
TYPE III BARRICADES CLOSING A ROAD**

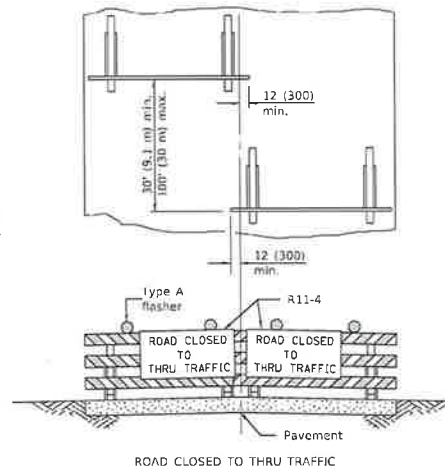

Reflectorized striping shall appear on both sides of the barricades. If a Type III barricade with an attached sign panel which meets NCHRP 350 is not available, the signs may be mounted on NCHRP 350 temporary sign supports directly in front of the barricade.

Illinois Department of Transportation

PASSED: *John Doe* (Signature), 2/13/10

APPROVED: *Thomas M. Baker* (Signature), 2/13/10

PROJECT: DESIGN AND ENVIRONMENT

**TRAFFIC CONTROL  
DEVICES**

(Sheet 3 of 3)

STANDARD 701901-07

