



VILLAGE OF VILLA PARK

CONTRACT DOCUMENTS

FOR

2018 STREET IMPROVEMENTS

AUGUST 10, 2018

PREPARED BY

CHRISTOPHER B. BURKE ENGINEERING, LTD.

9575 W. HIGGINS ROAD, SUITE 600
ROSEMONT, IL 60018

NOT FOR BID

**ADVERTISEMENT FOR BIDS
VILLAGE OF VILLA PARK
FRIDAY, AUGUST 10, 2018**

PROJECT: 2018 STREET IMPROVEMENTS

The base bid for this project consists of roadway pavement reconstruction at various locations throughout the Village. The project includes pavement removal, aggregate base course, Hot-Mix Asphalt Binder Course, Hot-Mix Asphalt Surface Course, curb and gutter removal and replacement, sidewalk removal and replacement, driveway pavement removal and replacement, drainage and utility structure adjustments, and landscape restoration.

The project will also include four alternate bids. Alternates 1 and 2 consist of the reconstruction of the Villa Park Public Works parking lot with either Hot-Mix Asphalt pavement or Portland Cement Concrete pavement, respectively. Alternate 3 consists of the removal and replacement of the Portland Cement Concrete driveway at the Villa Park Fire Station. Alternate 4 consists of the reconstruction of the southwest corner of the Sugar Creek Golf Course parking lot with Hot-Mix Asphalt pavement.

BID DEADLINE: TUESDAY, AUGUST 28, 2018, 10:00 A.M. LOCAL TIME

The Village reserves the right to extend the Bid Deadline from this date and time to accept Bids submitted after the Bid Deadline, as the Village, in its sole discretion, determines is in the best interest of the Village.

NOTICE: Separate, sealed proposals for the **2018 STREET IMPROVEMENTS** project will be received by the Village of Villa Park, Illinois, at the reception desk of the Public Works Department, 11 West Home Avenue, Villa Park, Illinois, 60181, until the Bid Deadline. Immediately thereafter, the proposals will be publicly opened and read aloud at the offices of the Public Works Department. Notwithstanding the foregoing, the Village reserves the right to defer, postpone, delay, or reschedule the Bid Opening for such time and to such date as the Village, in its sole discretion, determines is in the best interest of the Village.

Proposals shall be submitted in accordance with the Bidding Documents prepared by Christopher B. Burke Engineering, Ltd., 9575 W. Higgins Road, Rosemont, IL 60018.

BIDDER QUALIFICATIONS: Bidders, in submitting a Bid, shall comply with all applicable Federal, State and Local laws and requirements; shall provide documentation of that compliance in accordance with the requirements of the Contract Documents or as requested by the Village; and, in submitting a Bid, Bidders affirm that they are qualified under all applicable laws and requirements to do so, and agree to be bound by the determination of the Village as to Bidder's compliance and qualifications.

BID SECURITY: Bid security in the amount of not less than five percent (5%) of the Bid shall accompany each Bid in accordance with the Bidding Documents.

CONTRACT SECURITY: The Bidder to whom a Contract is awarded shall be required to furnish both a Performance Bond and a Payment Bond acceptable to the Village for one-hundred percent (100%) of the Contract Price, in accordance with the requirements of the Contract Documents.

RIGHTS RESERVED: The Village will select the lowest, most responsible bidder. The Village reserves the right to reject any and all Bids, to waive any informalities or technicalities in bidding, and to accept the Bid which best serves the interests of the Village. The Village shall, in its sole discretion, determine what does or does not constitute an informality or technicality, and, in submitting a Bid, Bidder agrees to be bound by that determination.

The Village may make such investigations as it deems necessary to determine the ability of the Bidder to perform the Work, and the Bidder shall furnish to the Village all such information and data for this purpose as the Village may request. The Village reserves the right to reject any Bid if the evidence submitted by, or investigation of, such Bidder fails to satisfy the Village that such Bidder is properly qualified to carry out the obligations of the Agreement and to complete the Work contemplated therein.

WAGE RATES: All applicable laws, ordinances, and the rules and regulations of all authorities having jurisdiction over construction of the PROJECT shall apply to the contract throughout.

CONTRACT DOCUMENTS: The Bidding Documents are on file for inspection at the office of the Village of Villa Park Public Works Department, 11 West Home Avenue, Villa Park, Illinois, 60181, and may also be obtained from the Village of Villa Park Public Works Department at the address listed above for a non-refundable fee of twenty dollars (\$20.00).

PUBLISHED BY AUTHORITY OF THE VILLAGE OF VILLA PARK, DUPAGE COUNTY, ILLINOIS.

BY:

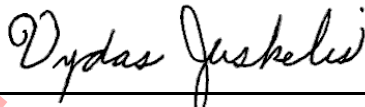

Vydas Juskelis, P.E.

Director of Public Works



**Illinois Department
of Transportation**

**Local Public Agency
Formal Contract
Proposal**

PROPOSAL SUBMITTED BY		
Contractor's Name		
Street	P.O. Box	
City	State	Zip Code

STATE OF ILLINOIS

COUNTY OF DUPAGE
VILLAGE OF VILLA PARK
 (Name of City, Village, Town or Road District)

FOR THE IMPROVEMENT OF

STREET NAME OR ROUTE NO. VARIOUS
 SECTION NO. N/A
 TYPES OF FUNDS LOCAL

SPECIFICATIONS (required)

PLANS (required)

NOT FOR BID

Note: All proposal documents, including Proposal Guaranty Checks or Proposal Bid Bonds, should be stapled together to prevent loss when bids are processed.

NOT FOR BID

RETURN WITH BID

NOTICE TO BIDDERS

County DUPAGE
Local Public Agency VILLA PARK
Section Number N/A
Route VARIOUS

Sealed proposals for the improvement described below will be received at the office of PUBLIC WORKS DEPARTMENT, 11 WEST HOME AVENUE, VILLA PARK, ILLINOIS 60181 until 10:00 AM on August 28, 2018

Sealed proposals will be opened and read publicly at the office of PUBLIC WORKS DEPARTMENT 11 WEST HOME AVENUE, VILLA PARK, ILLINOIS 60181 at 10:00 AM on August 28, 2018

DESCRIPTION OF WORK

Name 2018 STREET IMPROVEMENTS Length: 4320 feet (0.82 miles)
Location VARIOUS LOCATIONS THROUGHOUT VILLAGE OF VILLA PARK
Proposed Improvement PAVEMENT RECONSTRUCTION, CURB AND GUTTER REMOVAL AND REPLACEMENT, SIDEWALK REMOVAL AND REPLACEMENT, AND DRIVEWAY PAVEMENT REMOVAL AND REPLACEMENT

1. Plans and proposal forms will be available in the office of VILLAGE OF VILLA PARK PUBLIC WORKS FOR \$20 NON-REFUNDABLE FEE 11 WEST HOME AVENUE, VILLA PARK, ILLINOIS 60181, PHONE: (630) 834-8505

- 2. Prequalification
If checked, the 2 low bidders must file within 24 hours after the letting an "Affidavit of Availability" (Form BC 57), in duplicate, showing all uncompleted contracts awarded to them and all low bids pending award for Federal, State, County, Municipal and private work. One original shall be filed with the Awarding Authority and one original with the IDOT District Office.
3. The Awarding Authority reserves the right to waive technicalities and to reject any or all proposals as provided in BLRS Special Provision for Bidding Requirements and Conditions for Contract Proposals.
4. The following BLR Forms shall be returned by the bidder to the Awarding Authority:
a. BLR 12200: Local Public Agency Formal Contract Proposal
b. BLR 12200a Schedule of Prices
c. BLR 12230: Proposal Bid Bond (if applicable)
d. BLR 12325: Apprenticeship or Training Program Certification
e. BLR 12326: Affidavit of Illinois Business Office

NOT FOR BID

RETURN WITH BID

5. The quantities appearing in the bid schedule are approximate and are prepared for the comparison of bids. Payment to the Contractor will be made only for the actual quantities of work performed and accepted or materials furnished according to the contract. The scheduled quantities of work to be done and materials to be furnished may be increased, decreased or omitted as hereinafter provided.
6. Submission of a bid shall be conclusive assurance and warranty the bidder has examined the plans and understands all requirements for the performance of work. The bidder will be responsible for all errors in the proposal resulting from failure or neglect to conduct an in depth examination. The Awarding Authority will, in no case be responsible for any costs, expenses, losses or changes in anticipated profits resulting from such failure or neglect of the bidder.
7. The bidder shall take no advantage of any error or omission in the proposal and advertised contract.
8. If a special envelope is supplied by the Awarding Authority, each proposal should be submitted in that envelope furnished by the Awarding Agency and the blank spaces on the envelope shall be filled in correctly to clearly indicate its contents. When an envelope other than the special one furnished by the Awarding Authority is used, it shall be marked to clearly indicate its contents. When sent by mail, the sealed proposal shall be addressed to the Awarding Authority at the address and in care of the official in whose office the bids are to be received. All proposals shall be filed prior to the time and at the place specified in the Notice to Bidders. Proposals received after the time specified will be returned to the bidder unopened.
9. Permission will be given to a bidder to withdraw a proposal if the bidder makes the request in writing or in person before the time for opening proposals.

NOT FOR BID

RETURN WITH BID

PROPOSAL

County DUPAGE
Local Public Agency VILLA PARK
Section Number N/A
Route VARIOUS

1. Proposal of _____

for the improvement of the above section by the construction of PAVEMENT RECONSTRUCTION, CURB AND GUTTER REMOVAL AND REPLACEMENT, SIDEWALK REMOVAL AND REPLACEMENT, DRIVEWAY PAVEMENT REMOVAL AND REPLACEMENT, STRUCTURE ADJUSTMENTS, AND PARKWAY RESTORATION.

a total distance of 4320 feet, of which a distance of 4320 feet, (0.82 miles) are to be improved.

2. The plans for the proposed work are those prepared by CHRISTOPHER B. BURKE ENGINEERING, LTD and approved by the Department of Transportation on N/A

3. The specifications referred to herein are those prepared by the Department of Transportation and designated as "Standard Specifications for Road and Bridge Construction" and the "Supplemental Specifications and Recurring Special Provisions" thereto, adopted and in effect on the date of invitation for bids.

4. The undersigned agrees to accept, as part of the contract, the applicable Special Provisions indicated on the "Check Sheet for Recurring Special Provisions" contained in this proposal.

5. The undersigned agrees to complete the work within 60 calendar days or by --- unless additional time is granted in accordance with the specifications.

6. A proposal guaranty in the proper amount, as specified in BLRS Special Provision for Bidding Requirements and Conditions for Contract Proposals, will be required. Bid Bonds will be allowed as a proposal guaranty. Accompanying this proposal is either a bid bond if allowed, on Department form BLR 12230 or a proposal guaranty check, complying with the specifications, made payable to:

VILLAGE Treasurer of VILLA PARK

The amount of the check is 5% OF BID AMOUNT (_____).

7. In the event that one proposal guaranty check is intended to cover two or more proposals, the amount must be equal to the sum of the proposal guaranties, which would be required for each individual proposal. If the proposal guaranty check is placed in another proposal, it will be found in the proposal for: Section Number N/A _____.

8. The successful bidder at the time of execution of the contract will be required to deposit a contract bond for the full amount of the award. When a contract bond is not required, the proposal guaranty check will be held in lieu thereof. If this proposal is accepted and the undersigned fails to execute a contract and contract bond as required, it is hereby agreed that the Bid Bond or check shall be forfeited to the Awarding Authority.

9. Each pay item should have a unit price and a total price. If no total price is shown or if there is a discrepancy between the product of the unit price multiplied by the quantity, the unit price shall govern. If a unit price is omitted, the total price will be divided by the quantity in order to establish a unit price.

10. A bid will be declared unacceptable if neither a unit price nor a total price is shown.

11. The undersigned submits herewith the schedule of prices on BLR 12200a covering the work to be performed under this contract.

12. The undersigned further agrees that if awarded the contract for the sections contained in the combinations on BLR 12200a, the work shall be in accordance with the requirements of each individual proposal for the multiple bid specified in the Schedule for Multiple Bids below.

13. The undersigned is aware that Federal Labor Standards, Prevailing Wage Rates, and Section 3 Regulations apply to all work performed on this contract. It is the Contractor's responsibility to comply with these requirements and to assure compliance by his/her Subcontractors and/or any lower tier Subcontractors required by this contract.

NOT FOR BID

RETURN WITH BID



SCHEDULE OF PRICES

County DUPAGE
 Local Public Agency VILLA PARK
 Section NA
 Route VARIOUS

Schedule for Multiple Bids

Combination Letter	Sections Included in Combinations	Total

Schedule for Single Bid

(For complete information covering these items, see plans and specifications)

Bidder's Proposal for making BASE BID Improvements					
Item No.	Items	Unit	Quantity	Unit Price	Total
1	TREE REMOVAL (6 TO 15 UNITS DIAMETER)	UNIT	60		
2	TREE REMOVAL (OVER 15 UNITS DIAMETER)	UNIT	160		
3	TREE TRUNK PROTECTION	EACH	97		
4	TREE ROOT PRUNING	EACH	48		
5	TREE PRUNING	EACH	48		
6	REMOVAL AND DISPOSAL OF UNSUITABLE MATERIAL	CU YD	1000		
7	POROUS GRANULAR EMBANKMENT	CU YD	1000		
8	TRENCH BACKFILL	CU YD	450		
9	GEOTECHNICAL FABRIC FOR GROUND STABILIZATION	SQ YD	11570		
10	SODDING	SQ YD	5600		
11	SUPPLEMENTAL WATERING	UNIT	80		
12	INLET FILTERS	EACH	42		
13	AGGREGATE BASE COURSE, TYPE B 6"	SQ YD	11570		
14	BITUMINOUS MATERIALS (TACK COAT)	POUND	2745		
15	HOT-MIX ASPHALT BINDER COURSE, IL-19.0, N50	TON	2730		
16	HOT-MIX ASPHALT SURFACE COURSE, MIX "D", N50	TON	1365		
17	PORTLAND CEMENT CONCRETE DRIVEWAY PAVEMENT, 6 INCH	SQ YD	800		
18	PORTLAND CEMENT CONCRETE DRIVEWAY PAVEMENT, 8 INCH	SQ YD	150		
19	PORTLAND CEMENT CONCRETE SIDEWALK 5 INCH	SQ FT	17950		
20	PORTLAND CEMENT CONCRETE SIDEWALK 8 INCH	SQ FT	1400		

NOT FOR BID

RETURN WITH BID

Bidder's Proposal for making BASE BID Improvements					
Item No.	Items	Unit	Quantity	Unit Price	Total
21	DETECTABLE WARNINGS	SQ FT	200		
22	PAVEMENT REMOVAL	SQ YD	11690		
23	HOT-MIX ASPHALT SURFACE REMOVAL, 2"	SQ YD	5		
24	DRIVEWAY PAVEMENT REMOVAL	SQ YD	1750		
25	CURB REMOVAL	FOOT	0		
26	COMBINATION CURB AND GUTTER REMOVAL	FOOT	7540		
27	SIDEWALK REMOVAL	SQ FT	19530		
28	AGGREGATE SHOULDERS, TYPE A	SQ YD	0		
29	DOMESTIC WATER SERVICE BOXES TO BE ADJUSTED	EACH	20		
30	CATCH BASINS, TYPE C, TYPE 1 FRAME, OPEN LID	EACH	0		
31	INLETS, TYPE A, TYPE 11 FRAME AND GRATE	EACH	1		
32	VALVE BOXES TO BE ADJUSTED	EACH	2		
33	FRAMES AND GRATES, TYPE 11	EACH	7		
34	FRAMES AND LIDS, TYPE 1, OPEN LID	EACH	0		
35	FRAMES AND LIDS, TYPE 1, CLOSED LID	EACH	5		
36	CONCRETE CURB, TYPE B	FOOT	0		
37	COMBINATION CONCRETE CURB AND GUTTER, TYPE B-4.12	FOOT	1075		
38	COMBINATION CONCRETE CURB AND GUTTER, TYPE B-6.12	FOOT	6465		
39	THERMOPLASTIC PAVEMENT MARKING - LETTERS AND SYMBOLS	SQ FT	0		
40	THERMOPLASTIC PAVEMENT MARKING - LINE 4"	FOOT	0		
41	THERMOPLASTIC PAVEMENT MARKING - LINE 6"	FOOT	900		
42	THERMOPLASTIC PAVEMENT MARKING - LINE 24"	FOOT	145		
43	PAINT PAVEMENT MARKING - LETTERS AND SYMBOLS	SQ FT	0		
44	PAINT PAVEMENT MARKING - LINE 4"	FOOT	0		
45	EXPLORATION TRENCH, SPECIAL	FOOT	200		
46	TEMPORARY ACCESS (PRIVATE ENTRANCE)	EACH	94		
47	TEMPORARY ACCESS (COMMERCIAL ENTRANCE)	EACH	8		
48	TEMPORARY ACCESS (ROAD)	EACH	20		
49	TRAFFIC CONTROL AND PROTECTION, (SPECIAL)	L SUM	1		
50	CONSTRUCTION LAYOUT	L SUM	1		

NOT FOR BID

RETURN WITH BID

Bidder's Proposal for making BASE BID Improvements					
Item No.	Items	Unit	Quantity	Unit Price	Total
51	DRAINAGE & UTILITY STRUCTURES TO BE ADJUSTED	EACH	44		
52	DRAINAGE & UTILITY STRUCTURES TO BE RECONSTRUCTED	EACH	7		
53	HOT-MIX ASPHALT DRIVEWAY PAVEMENT, 4"	SQ YD	720		
54	HOT-MIX ASPHALT DRIVEWAY PAVEMENT, 6"	SQ YD	80		
55	BRICK DRIVEWAY REMOVAL AND REPLACEMENT	SQ YD	30		
56	BRICK PAVER REMOVAL	SQ YD	10		
57	STRUCTURE TO BE REMOVED	EACH	1		
58	STORM SEWERS, CLASS B (PVC), 6"	FOOT	200		
59	SANITARY MANHOLE, TYPE A, 4'-DIAMETER, TYPE 1 FRAME, CLOSED LID	EACH	2		
60	SANITARY SERVICE CONNECTION	EACH	14		
61	SANITARY SERVICE REPLACEMENT	FOOT	350		
62	SANITARY SEWER SERVICE COMBINATION CLEANOUT CHECK VALVE	EACH	14		
63	WATER SERVICE CONNECTION (LONG), 1"	EACH	10		
64	WATER SERVICE CONNECTION (SHORT), 1"	EACH	10		
65	WATER USAGE CREDIT	TGAL	100	\$8.85	\$885.00
66	WATER USAGE DEDUCTION	TGAL	100	-\$8.85	-\$885.00
67	PRE-CONSTRUCTION VIDEO RECORDING	L SUM	1		
68	CONTINGENCY ALLOWANCE	DOLLARS	50000	\$1.00	\$50,000.00
END OF SCHEDULE OF PRICES				BASE BID TOTAL =	

NOT FOR BID



SCHEDULE OF PRICES

County DUPAGE
 Local Public Agency VILLA PARK
 Section NA
 Route VARIOUS

Schedule for Multiple Bids

Combination Letter	Sections Included in Combinations	Total

Schedule for Single Bid

(For complete information covering these items, see plans and specifications)

Bidder's Proposal for making ALTERNATE 1 Improvements					
Item No.	Items	Unit	Quantity	Unit Price	Total
A1-1	TREE REMOVAL (6 TO 15 UNITS DIAMETER)	UNIT	0		
A1-2	TREE REMOVAL (OVER 15 UNITS DIAMETER)	UNIT	0		
A1-3	TREE TRUNK PROTECTION	EACH	0		
A1-4	TREE ROOT PRUNING	EACH	0		
A1-5	TREE PRUNING	EACH	0		
A1-6	REMOVAL AND DISPOSAL OF UNSUITABLE MATERIAL	CU YD	60		
A1-7	POROUS GRANULAR EMBANKMENT	CU YD	60		
A1-8	TRENCH BACKFILL	CU YD	0		
A1-9	GEOTECHNICAL FABRIC FOR GROUND STABILIZATION	SQ YD	1750		
A1-10	SODDING	SQ YD	90		
A1-11	SUPPLEMENTAL WATERING	UNIT	5		
A1-12	INLET FILTERS	EACH	5		
A1-13	AGGREGATE BASE COURSE, TYPE B 6"	SQ YD	1750		
A1-14	BITUMINOUS MATERIALS (TACK COAT)	POUND	415		
A1-15	HOT-MIX ASPHALT BINDER COURSE, IL-19.0, N50	TON	415		
A1-16	HOT-MIX ASPHALT SURFACE COURSE, MIX "D", N50	TON	210		
A1-17	PORTLAND CEMENT CONCRETE DRIVEWAY PAVEMENT, 6 INCH	SQ YD	0		
A1-18	PORTLAND CEMENT CONCRETE DRIVEWAY PAVEMENT, 8 INCH	SQ YD	0		
A1-19	PORTLAND CEMENT CONCRETE SIDEWALK 5 INCH	SQ FT	200		
A1-20	PORTLAND CEMENT CONCRETE SIDEWALK 8 INCH	SQ FT	200		

NOT FOR BID

RETURN WITH BID

Bidder's Proposal for making ALTERNATE 1 Improvements					
Item No.	Items	Unit	Quantity	Unit Price	Total
A1-21	DETECTABLE WARNINGS	SQ FT	0		
A1-22	PAVEMENT REMOVAL	SQ YD	1750		
A1-23	HOT-MIX ASPHALT SURFACE REMOVAL, 2"	SQ YD	0		
A1-24	DRIVEWAY PAVEMENT REMOVAL	SQ YD	0		
A1-25	CURB REMOVAL	FOOT	80		
A1-26	COMBINATION CURB AND GUTTER REMOVAL	FOOT	0		
A1-27	SIDEWALK REMOVAL	SQ FT	400		
A1-28	AGGREGATE SHOULDERS, TYPE A	SQ YD	0		
A1-29	DOMESTIC WATER SERVICE BOXES TO BE ADJUSTED	EACH	0		
A1-30	CATCH BASINS, TYPE C, TYPE 1 FRAME, OPEN LID	EACH	2		
A1-31	INLETS, TYPE A, TYPE 11 FRAME AND GRATE	EACH	0		
A1-32	VALVE BOXES TO BE ADJUSTED	EACH	0		
A1-33	FRAMES AND GRATES, TYPE 11	EACH	0		
A1-34	FRAMES AND LIDS, TYPE 1, OPEN LID	EACH	2		
A1-35	FRAMES AND LIDS, TYPE 1, CLOSED LID	EACH	0		
A1-36	CONCRETE CURB, TYPE B	FOOT	360		
A1-37	COMBINATION CONCRETE CURB AND GUTTER, TYPE B-4.12	FOOT	0		
A1-38	COMBINATION CONCRETE CURB AND GUTTER, TYPE B-6.12	FOOT	0		
A1-39	THERMOPLASTIC PAVEMENT MARKING - LETTERS AND SYMBOLS	SQ FT	5		
A1-40	THERMOPLASTIC PAVEMENT MARKING - LINE 4"	FOOT	1300		
A1-41	THERMOPLASTIC PAVEMENT MARKING - LINE 6"	FOOT	0		
A1-42	THERMOPLASTIC PAVEMENT MARKING - LINE 24"	FOOT	0		
A1-43	PAINT PAVEMENT MARKING - LETTERS AND SYMBOLS	SQ FT	0		
A1-44	PAINT PAVEMENT MARKING - LINE 4"	FOOT	0		
A1-45	EXPLORATION TRENCH, SPECIAL	FOOT	0		
A1-46	TEMPORARY ACCESS (PRIVATE ENTRANCE)	EACH	0		
A1-47	TEMPORARY ACCESS (COMMERCIAL ENTRANCE)	EACH	1		
A1-48	TEMPORARY ACCESS (ROAD)	EACH	0		
A1-49	TRAFFIC CONTROL AND PROTECTION, (SPECIAL)	L SUM	1		
A1-50	CONSTRUCTION LAYOUT	L SUM	1		

NOT FOR BID

RETURN WITH BID

Bidder's Proposal for making ALTERNATE 1 Improvements					
Item No.	Items	Unit	Quantity	Unit Price	Total
A1-51	DRAINAGE & UTILITY STRUCTURES TO BE ADJUSTED	EACH	3		
A1-52	DRAINAGE & UTILITY STRUCTURES TO BE RECONSTRUCTED	EACH	0		
A1-53	HOT-MIX ASPHALT DRIVEWAY PAVEMENT, 4"	SQ YD	0		
A1-54	HOT-MIX ASPHALT DRIVEWAY PAVEMENT, 6"	SQ YD	0		
A1-55	BRICK DRIVEWAY REMOVAL AND REPLACEMENT	SQ YD	0		
A1-56	BRICK PAVER REMOVAL	SQ YD	0		
A1-57	STRUCTURE TO BE REMOVED	EACH	0		
A1-58	STORM SEWERS, CLASS B (PVC), 6"	FOOT	0		
A1-59	SANITARY MANHOLE, TYPE A, 4'-DIAMETER, TYPE 1 FRAME, CLOSED LID	EACH	0		
A1-60	SANITARY SERVICE CONNECTION	EACH	0		
A1-61	SANITARY SERVICE REPLACEMENT	FOOT	0		
A1-62	SANITARY SEWER SERVICE COMBINATION CLEANOUT CHECK VALVE	EACH	0		
A1-63	WATER SERVICE CONNECTION (LONG), 1"	EACH	0		
A1-64	WATER SERVICE CONNECTION (SHORT), 1"	EACH	0		
A1-65	WATER USAGE CREDIT	TGAL	100	\$8.85	\$885.00
A1-66	WATER USAGE DEDUCTION	TGAL	100	-\$8.85	-\$885.00
A1-67	PRE-CONSTRUCTION VIDEO RECORDING	L SUM	1		
A1-68	CONTINGENCY ALLOWANCE	DOLLARS	5000	\$1.00	\$5,000.00
END OF SCHEDULE OF PRICES				ALTERNATE 1 TOTAL =	

NOT FOR BID



SCHEDULE OF PRICES

County DUPAGE
 Local Public Agency VILLA PARK
 Section NA
 Route VARIOUS

Schedule for Multiple Bids

Combination Letter	Sections Included in Combinations	Total

Schedule for Single Bid

(For complete information covering these items, see plans and specifications)

Bidder's Proposal for making ALTERNATE 2 Improvements					
Item No.	Items	Unit	Quantity	Unit Price	Total
A2-1	TREE REMOVAL (6 TO 15 UNITS DIAMETER)	UNIT	0		
A2-2	TREE REMOVAL (OVER 15 UNITS DIAMETER)	UNIT	0		
A2-3	TREE TRUNK PROTECTION	EACH	0		
A2-4	TREE ROOT PRUNING	EACH	0		
A2-5	TREE PRUNING	EACH	0		
A2-6	REMOVAL AND DISPOSAL OF UNSUITABLE MATERIAL	CU YD	60		
A2-7	POROUS GRANULAR EMBANKMENT	CU YD	60		
A2-8	TRENCH BACKFILL	CU YD	0		
A2-9	GEOTECHNICAL FABRIC FOR GROUND STABILIZATION	SQ YD	1750		
A2-10	SODDING	SQ YD	90		
A2-11	SUPPLEMENTAL WATERING	UNIT	5		
A2-12	INLET FILTERS	EACH	5		
A2-13	AGGREGATE BASE COURSE, TYPE B 6"	SQ YD	0		
A2-14	BITUMINOUS MATERIALS (TACK COAT)	POUND	0		
A2-15	HOT-MIX ASPHALT BINDER COURSE, IL-19.0, N50	TON	0		
A2-16	HOT-MIX ASPHALT SURFACE COURSE, MIX "D", N50	TON	0		
A2-17	PORTLAND CEMENT CONCRETE DRIVEWAY PAVEMENT, 6 INCH	SQ YD	0		
A2-18	PORTLAND CEMENT CONCRETE DRIVEWAY PAVEMENT, 8 INCH	SQ YD	1750		
A2-19	PORTLAND CEMENT CONCRETE SIDEWALK 5 INCH	SQ FT	200		
A2-20	PORTLAND CEMENT CONCRETE SIDEWALK 8 INCH	SQ FT	200		

NOT FOR BID

RETURN WITH BID

Bidder's Proposal for making ALTERNATE 2 Improvements					
Item No.	Items	Unit	Quantity	Unit Price	Total
A2-21	DETECTABLE WARNINGS	SQ FT	0		
A2-22	PAVEMENT REMOVAL	SQ YD	1750		
A2-23	HOT-MIX ASPHALT SURFACE REMOVAL, 2"	SQ YD	0		
A2-24	DRIVEWAY PAVEMENT REMOVAL	SQ YD	0		
A2-25	CURB REMOVAL	FOOT	80		
A2-26	COMBINATION CURB AND GUTTER REMOVAL	FOOT	0		
A2-27	SIDEWALK REMOVAL	SQ FT	400		
A2-28	AGGREGATE SHOULDERS, TYPE A	SQ YD	0		
A2-29	DOMESTIC WATER SERVICE BOXES TO BE ADJUSTED	EACH	0		
A2-30	CATCH BASINS, TYPE C, TYPE 1 FRAME, OPEN LID	EACH	2		
A2-31	INLETS, TYPE A, TYPE 11 FRAME AND GRATE	EACH	0		
A2-32	VALVE BOXES TO BE ADJUSTED	EACH	0		
A2-33	FRAMES AND GRATES, TYPE 11	EACH	0		
A2-34	FRAMES AND LIDS, TYPE 1, OPEN LID	EACH	2		
A2-35	FRAMES AND LIDS, TYPE 1, CLOSED LID	EACH	0		
A2-36	CONCRETE CURB, TYPE B	FOOT	110		
A2-37	COMBINATION CONCRETE CURB AND GUTTER, TYPE B-4.12	FOOT	0		
A2-38	COMBINATION CONCRETE CURB AND GUTTER, TYPE B-6.12	FOOT	0		
A2-39	THERMOPLASTIC PAVEMENT MARKING - LETTERS AND SYMBOLS	SQ FT	0		
A2-40	THERMOPLASTIC PAVEMENT MARKING - LINE 4"	FOOT	0		
A2-41	THERMOPLASTIC PAVEMENT MARKING - LINE 6"	FOOT	0		
A2-42	THERMOPLASTIC PAVEMENT MARKING - LINE 24"	FOOT	0		
A2-43	PAINT PAVEMENT MARKING - LETTERS AND SYMBOLS	SQ FT	5		
A2-44	PAINT PAVEMENT MARKING - LINE 4"	FOOT	1300		
A2-45	EXPLORATION TRENCH, SPECIAL	FOOT	0		
A2-46	TEMPORARY ACCESS (PRIVATE ENTRANCE)	EACH	0		
A2-47	TEMPORARY ACCESS (COMMERCIAL ENTRANCE)	EACH	1		
A2-48	TEMPORARY ACCESS (ROAD)	EACH	0		
A2-49	TRAFFIC CONTROL AND PROTECTION, (SPECIAL)	L SUM	1		
A2-50	CONSTRUCTION LAYOUT	L SUM	1		

NOT FOR BID

RETURN WITH BID

Bidder's Proposal for making ALTERNATE 2 Improvements					
Item No.	Items	Unit	Quantity	Unit Price	Total
A2-51	DRAINAGE & UTILITY STRUCTURES TO BE ADJUSTED	EACH	3		
A2-52	DRAINAGE & UTILITY STRUCTURES TO BE RECONSTRUCTED	EACH	0		
A2-53	HOT-MIX ASPHALT DRIVEWAY PAVEMENT, 4"	SQ YD	0		
A2-54	HOT-MIX ASPHALT DRIVEWAY PAVEMENT, 6"	SQ YD	0		
A2-55	BRICK DRIVEWAY REMOVAL AND REPLACEMENT	SQ YD	0		
A2-56	BRICK PAVER REMOVAL	SQ YD	0		
A2-57	STRUCTURE TO BE REMOVED	EACH	0		
A2-58	STORM SEWERS, CLASS B (PVC), 6"	FOOT	0		
A2-59	SANITARY MANHOLE, TYPE A, 4'-DIAMETER, TYPE 1 FRAME, CLOSED LID	EACH	0		
A2-60	SANITARY SERVICE CONNECTION	EACH	0		
A2-61	SANITARY SERVICE REPLACEMENT	FOOT	0		
A2-62	SANITARY SEWER SERVICE COMBINATION CLEANOUT CHECK VALVE	EACH	0		
A2-63	WATER SERVICE CONNECTION (LONG), 1"	EACH	0		
A2-64	WATER SERVICE CONNECTION (SHORT), 1"	EACH	0		
A2-65	WATER USAGE CREDIT	TGAL	100	\$8.85	\$885.00
A2-66	WATER USAGE DEDUCTION	TGAL	100	-\$8.85	-\$885.00
A2-67	PRE-CONSTRUCTION VIDEO RECORDING	L SUM	1		
A2-68	CONTINGENCY ALLOWANCE	DOLLARS	5000	\$1.00	\$5,000.00
END OF SCHEDULE OF PRICES				ALTERNATE 2 TOTAL =	

NOT FOR BID



SCHEDULE OF PRICES

County DUPAGE
 Local Public Agency VILLA PARK
 Section NA
 Route VARIOUS

Schedule for Multiple Bids

Combination Letter	Sections Included in Combinations	Total

Schedule for Single Bid

(For complete information covering these items, see plans and specifications)

Bidder's Proposal for making ALTERNATE 3 Improvements					
Item No.	Items	Unit	Quantity	Unit Price	Total
A3-1	TREE REMOVAL (6 TO 15 UNITS DIAMETER)	UNIT	0		
A3-2	TREE REMOVAL (OVER 15 UNITS DIAMETER)	UNIT	0		
A3-3	TREE TRUNK PROTECTION	EACH	0		
A3-4	TREE ROOT PRUNING	EACH	0		
A3-5	TREE PRUNING	EACH	0		
A3-6	REMOVAL AND DISPOSAL OF UNSUITABLE MATERIAL	CU YD	0		
A3-7	POROUS GRANULAR EMBANKMENT	CU YD	0		
A3-8	TRENCH BACKFILL	CU YD	0		
A3-9	GEOTECHNICAL FABRIC FOR GROUND STABILIZATION	SQ YD	1000		
A3-10	SODDING	SQ YD	120		
A3-11	SUPPLEMENTAL WATERING	UNIT	5		
A3-12	INLET FILTERS	EACH	1		
A3-13	AGGREGATE BASE COURSE, TYPE B 6"	SQ YD	0		
A3-14	BITUMINOUS MATERIALS (TACK COAT)	POUND	20		
A3-15	HOT-MIX ASPHALT BINDER COURSE, IL-19.0, N50	TON	0		
A3-16	HOT-MIX ASPHALT SURFACE COURSE, MIX "D", N50	TON	5		
A3-17	PORTLAND CEMENT CONCRETE DRIVEWAY PAVEMENT, 6 INCH	SQ YD	0		
A3-18	PORTLAND CEMENT CONCRETE DRIVEWAY PAVEMENT, 8 INCH	SQ YD	1000		
A3-19	PORTLAND CEMENT CONCRETE SIDEWALK 5 INCH	SQ FT	250		
A3-20	PORTLAND CEMENT CONCRETE SIDEWALK 8 INCH	SQ FT	400		

NOT FOR BID

RETURN WITH BID

Bidder's Proposal for making ALTERNATE 3 Improvements					
Item No.	Items	Unit	Quantity	Unit Price	Total
A3-21	DETECTABLE WARNINGS	SQ FT	0		
A3-22	PAVEMENT REMOVAL	SQ YD	0		
A3-23	HOT-MIX ASPHALT SURFACE REMOVAL, 2"	SQ YD	35		
A3-24	DRIVEWAY PAVEMENT REMOVAL	SQ YD	1000		
A3-25	CURB REMOVAL	FOOT	0		
A3-26	COMBINATION CURB AND GUTTER REMOVAL	FOOT	225		
A3-27	SIDEWALK REMOVAL	SQ FT	650		
A3-28	AGGREGATE SHOULDERS, TYPE A	SQ YD	0		
A3-29	DOMESTIC WATER SERVICE BOXES TO BE ADJUSTED	EACH	0		
A3-30	CATCH BASINS, TYPE C, TYPE 1 FRAME, OPEN LID	EACH	0		
A3-31	INLETS, TYPE A, TYPE 11 FRAME AND GRATE	EACH	0		
A3-32	VALVE BOXES TO BE ADJUSTED	EACH	0		
A3-33	FRAMES AND GRATES, TYPE 11	EACH	0		
A3-34	FRAMES AND LIDS, TYPE 1, OPEN LID	EACH	0		
A3-35	FRAMES AND LIDS, TYPE 1, CLOSED LID	EACH	0		
A3-36	CONCRETE CURB, TYPE B	FOOT	0		
A3-37	COMBINATION CONCRETE CURB AND GUTTER, TYPE B-4.12	FOOT	0		
A3-38	COMBINATION CONCRETE CURB AND GUTTER, TYPE B-6.12	FOOT	225		
A3-39	THERMOPLASTIC PAVEMENT MARKING - LETTERS AND SYMBOLS	SQ FT	0		
A3-40	THERMOPLASTIC PAVEMENT MARKING - LINE 4"	FOOT	0		
A3-41	THERMOPLASTIC PAVEMENT MARKING - LINE 6"	FOOT	0		
A3-42	THERMOPLASTIC PAVEMENT MARKING - LINE 24"	FOOT	0		
A3-43	PAINT PAVEMENT MARKING - LETTERS AND SYMBOLS	SQ FT	0		
A3-44	PAINT PAVEMENT MARKING - LINE 4"	FOOT	0		
A3-45	EXPLORATION TRENCH, SPECIAL	FOOT	0		
A3-46	TEMPORARY ACCESS (PRIVATE ENTRANCE)	EACH	0		
A3-47	TEMPORARY ACCESS (COMMERCIAL ENTRANCE)	EACH	1		
A3-48	TEMPORARY ACCESS (ROAD)	EACH	0		
A3-49	TRAFFIC CONTROL AND PROTECTION, (SPECIAL)	L SUM	1		
A3-50	CONSTRUCTION LAYOUT	L SUM	1		

NOT FOR BID

RETURN WITH BID

Bidder's Proposal for making ALTERNATE 3 Improvements					
Item No.	Items	Unit	Quantity	Unit Price	Total
A3-51	DRAINAGE & UTILITY STRUCTURES TO BE ADJUSTED	EACH	2		
A3-52	DRAINAGE & UTILITY STRUCTURES TO BE RECONSTRUCTED	EACH	0		
A3-53	HOT-MIX ASPHALT DRIVEWAY PAVEMENT, 4"	SQ YD	0		
A3-54	HOT-MIX ASPHALT DRIVEWAY PAVEMENT, 6"	SQ YD	0		
A3-55	BRICK DRIVEWAY REMOVAL AND REPLACEMENT	SQ YD	0		
A3-56	BRICK PAVER REMOVAL	SQ YD	0		
A3-57	STRUCTURE TO BE REMOVED	EACH	0		
A3-58	STORM SEWERS, CLASS B (PVC), 6"	FOOT	0		
A3-59	SANITARY MANHOLE, TYPE A, 4'-DIAMETER, TYPE 1 FRAME, CLOSED LID	EACH	0		
A3-60	SANITARY SERVICE CONNECTION	EACH	0		
A3-61	SANITARY SERVICE REPLACEMENT	FOOT	0		
A3-62	SANITARY SEWER SERVICE COMBINATION CLEANOUT CHECK VALVE	EACH	0		
A3-63	WATER SERVICE CONNECTION (LONG), 1"	EACH	0		
A3-64	WATER SERVICE CONNECTION (SHORT), 1"	EACH	0		
A3-65	WATER USAGE CREDIT	TGAL	100	\$8.85	\$885.00
A3-66	WATER USAGE DEDUCTION	TGAL	100	-\$8.85	-\$885.00
A3-67	PRE-CONSTRUCTION VIDEO RECORDING	L SUM	1		
A3-68	CONTINGENCY ALLOWANCE	DOLLARS	5000	\$1.00	\$5,000.00
END OF SCHEDULE OF PRICES				ALTERNATE 3 TOTAL =	

NOT FOR BID



SCHEDULE OF PRICES

County DUPAGE
 Local Public Agency VILLA PARK
 Section NA
 Route VARIOUS

Schedule for Multiple Bids

Combination Letter	Sections Included in Combinations	Total

Schedule for Single Bid

(For complete information covering these items, see plans and specifications)

Bidder's Proposal for making ALTERNATE 4 Improvements					
Item No.	Items	Unit	Quantity	Unit Price	Total
A4-1	TREE REMOVAL (6 TO 15 UNITS DIAMETER)	UNIT	0		
A4-2	TREE REMOVAL (OVER 15 UNITS DIAMETER)	UNIT	0		
A4-3	TREE TRUNK PROTECTION	EACH	0		
A4-4	TREE ROOT PRUNING	EACH	0		
A4-5	TREE PRUNING	EACH	0		
A4-6	REMOVAL AND DISPOSAL OF UNSUITABLE MATERIAL	CU YD	50		
A4-7	POROUS GRANULAR EMBANKMENT	CU YD	50		
A4-8	TRENCH BACKFILL	CU YD	0		
A4-9	GEOTECHNICAL FABRIC FOR GROUND STABILIZATION	SQ YD	1430		
A4-10	SODDING	SQ YD	50		
A4-11	SUPPLEMENTAL WATERING	UNIT	5		
A4-12	INLET FILTERS	EACH	1		
A4-13	AGGREGATE BASE COURSE, TYPE B 6"	SQ YD	1430		
A4-14	BITUMINOUS MATERIALS (TACK COAT)	POUND	340		
A4-15	HOT-MIX ASPHALT BINDER COURSE, IL-19.0, N50	TON	340		
A4-16	HOT-MIX ASPHALT SURFACE COURSE, MIX "D", N50	TON	170		
A4-17	PORTLAND CEMENT CONCRETE DRIVEWAY PAVEMENT, 6 INCH	SQ YD	0		
A4-18	PORTLAND CEMENT CONCRETE DRIVEWAY PAVEMENT, 8 INCH	SQ YD	0		
A4-19	PORTLAND CEMENT CONCRETE SIDEWALK 5 INCH	SQ FT	0		
A4-20	PORTLAND CEMENT CONCRETE SIDEWALK 8 INCH	SQ FT	0		

NOT FOR BID

RETURN WITH BID

Bidder's Proposal for making ALTERNATE 4 Improvements					
Item No.	Items	Unit	Quantity	Unit Price	Total
A4-21	DETECTABLE WARNINGS	SQ FT	0		
A4-22	PAVEMENT REMOVAL	SQ YD	1430		
A4-23	HOT-MIX ASPHALT SURFACE REMOVAL, 2"	SQ YD	0		
A4-24	DRIVEWAY PAVEMENT REMOVAL	SQ YD	0		
A4-25	CURB REMOVAL	FOOT	0		
A4-26	COMBINATION CURB AND GUTTER REMOVAL	FOOT	55		
A4-27	SIDEWALK REMOVAL	SQ FT	0		
A4-28	AGGREGATE SHOULDERS, TYPE A	SQ YD	200		
A4-29	DOMESTIC WATER SERVICE BOXES TO BE ADJUSTED	EACH	0		
A4-30	CATCH BASINS, TYPE C, TYPE 1 FRAME, OPEN LID	EACH	0		
A4-31	INLETS, TYPE A, TYPE 11 FRAME AND GRATE	EACH	0		
A4-32	VALVE BOXES TO BE ADJUSTED	EACH	0		
A4-33	FRAMES AND GRATES, TYPE 11	EACH	0		
A4-34	FRAMES AND LIDS, TYPE 1, OPEN LID	EACH	0		
A4-35	FRAMES AND LIDS, TYPE 1, CLOSED LID	EACH	0		
A4-36	CONCRETE CURB, TYPE B	FOOT	0		
A4-37	COMBINATION CONCRETE CURB AND GUTTER, TYPE B-4.12	FOOT	55		
A4-38	COMBINATION CONCRETE CURB AND GUTTER, TYPE B-6.12	FOOT	0		
A4-39	THERMOPLASTIC PAVEMENT MARKING - LETTERS AND SYMBOLS	SQ FT	0		
A4-40	THERMOPLASTIC PAVEMENT MARKING - LINE 4"	FOOT	700		
A4-41	THERMOPLASTIC PAVEMENT MARKING - LINE 6"	FOOT	0		
A4-42	THERMOPLASTIC PAVEMENT MARKING - LINE 24"	FOOT	11		
A4-43	PAINT PAVEMENT MARKING - LETTERS AND SYMBOLS	SQ FT	0		
A4-44	PAINT PAVEMENT MARKING - LINE 4"	FOOT	0		
A4-45	EXPLORATION TRENCH, SPECIAL	FOOT	0		
A4-46	TEMPORARY ACCESS (PRIVATE ENTRANCE)	EACH	0		
A4-47	TEMPORARY ACCESS (COMMERCIAL ENTRANCE)	EACH	1		
A4-48	TEMPORARY ACCESS (ROAD)	EACH	0		
A4-49	TRAFFIC CONTROL AND PROTECTION, (SPECIAL)	L SUM	1		
A4-50	CONSTRUCTION LAYOUT	L SUM	1		

NOT FOR BID

RETURN WITH BID

Bidder's Proposal for making ALTERNATE 4 Improvements					
Item No.	Items	Unit	Quantity	Unit Price	Total
A4-51	DRAINAGE & UTILITY STRUCTURES TO BE ADJUSTED	EACH	0		
A4-52	DRAINAGE & UTILITY STRUCTURES TO BE RECONSTRUCTED	EACH	0		
A4-53	HOT-MIX ASPHALT DRIVEWAY PAVEMENT, 4"	SQ YD	0		
A4-54	HOT-MIX ASPHALT DRIVEWAY PAVEMENT, 6"	SQ YD	0		
A4-55	BRICK DRIVEWAY REMOVAL AND REPLACEMENT	SQ YD	0		
A4-56	BRICK PAVER REMOVAL	SQ YD	0		
A4-57	STRUCTURE TO BE REMOVED	EACH	0		
A4-58	STORM SEWERS, CLASS B (PVC), 6"	FOOT	0		
A4-59	SANITARY MANHOLE, TYPE A, 4'-DIAMETER, TYPE 1 FRAME, CLOSED LID	EACH	0		
A4-60	SANITARY SERVICE CONNECTION	EACH	0		
A4-61	SANITARY SERVICE REPLACEMENT	FOOT	0		
A4-62	SANITARY SEWER SERVICE COMBINATION CLEANOUT CHECK VALVE	EACH	0		
A4-63	WATER SERVICE CONNECTION (LONG), 1"	EACH	0		
A4-64	WATER SERVICE CONNECTION (SHORT), 1"	EACH	0		
A4-65	WATER USAGE CREDIT	TGAL	100	\$8.85	\$885.00
A4-66	WATER USAGE DEDUCTION	TGAL	100	-\$8.85	-\$885.00
A4-67	PRE-CONSTRUCTION VIDEO RECORDING	L SUM	1		
A4-68	CONTINGENCY ALLOWANCE	DOLLARS	5000	\$1.00	\$5,000.00
END OF SCHEDULE OF PRICES				ALTERNATE 4 TOTAL =	

NOT FOR BID

RETURN WITH BID

CONTRACTOR CERTIFICATIONS

County	DUPAGE
Local Public Agency	VILLA PARK
Section Number	N/A
Route	VARIOUS

The certifications hereinafter made by the bidder are each a material representation of fact upon which reliance is placed should the Department enter into the contract with the bidder.

1. **Debt Delinquency.** The bidder or contractor or subcontractor, respectively, certifies that it is not delinquent in the payment of any tax administered by the Department of Revenue unless the individual or other entity is contesting, in accordance with the procedures established by the appropriate revenue Act, its liability for the tax or the amount of tax. Making a false statement voids the contract and allows the Department to recover all amounts paid to the individual or entity under the contract in a civil action.

2. **Bid-Rigging or Bid Rotating.** The bidder or contractor or subcontractor, respectively, certifies that it is not barred from contracting with the Department by reason of a violation of either 720 ILCS 5/33E-3 or 720 ILCS 5/33E-4.

A violation of Section 33E-3 would be represented by a conviction of the crime of bid-rigging which, in addition to Class 3 felony sentencing, provides that any person convicted of this offense or any similar offense of any state or the United States which contains the same elements as this offense shall be barred for 5 years from the date of conviction from contracting with any unit of State or local government. No corporation shall be barred from contracting with any unit of State or local government as a result of a conviction under this Section of any employee or agent of such corporation if the employee so convicted is no longer employed by the corporation and: (1) it has been finally adjudicated not guilty or (2) if it demonstrates to the governmental entity with which it seeks to contract and that entity finds that the commission of the offense was neither authorized, requested, commanded, nor performed by a director, officer or a high managerial agent in behalf of the corporation.

A violation of Section 33E-4 would be represented by a conviction of the crime of bid-rotating which, in addition to Class 2 felony sentencing, provides that any person convicted of this offense or any similar offense of any state or the United States which contains the same elements as this offense shall be permanently barred from contracting with any unit of State or local government. No corporation shall be barred from contracting with any unit of State or local government as a result of a conviction under this Section of any employee or agent of such corporation if the employee so convicted is no longer employed by the corporation and: (1) it has been finally adjudicated not guilty or (2) if it demonstrates to the governmental entity with which it seeks to contract and that entity finds that the commission of the offense was neither authorized, requested, commanded, nor performed by a director, officer or a high managerial agent in behalf of the corporation.

3. **Bribery.** The bidder or contractor or subcontractor, respectively, certifies that it has not been convicted of bribery or attempting to bribe an officer or employee of the State of Illinois or any unit of local government, nor has the firm made an admission of guilt of such conduct which is a matter of record, nor has an official, agent, or employee of the firm committed bribery or attempted bribery on behalf of the firm and pursuant to the direction or authorization of a responsible official of the firm.

4. **Interim Suspension or Suspension.** The bidder or contractor or subcontractor, respectively, certifies that it is not currently under a suspension as defined in Subpart I of Title 44 Subtitle A Chapter III Part 6 of the Illinois Administrative Code. Furthermore, if suspended prior to completion of this work, the contract or contracts executed for the completion of this work may be cancelled.

NOT FOR BID

RETURN WITH BID

SIGNATURES

County DUPAGE
Local Public Agency VILLA PARK
Section Number N/A
Route VARIOUS

(If an individual)

Signature of Bidder _____

Business Address _____

(If a partnership)

Firm Name _____

Signed By _____

Business Address _____

Inset Names and Addressed of All Partners



(If a corporation)

Corporate Name _____

Signed By _____

President

Business Address _____

Inset Names of Officers



President _____

Secretary _____

Treasurer _____

Attest: _____
Secretary

NOT FOR BID

Route VARIOUS
 County DUPAGE
 Local Agency VILLA PARK
 Section NA

RETURN WITH BID

PAPER BID BOND

WE _____ as PRINCIPAL,
 and _____ as SURETY,

are held jointly, severally and firmly bound unto the above Local Agency (hereafter referred to as "LA") in the penal sum of 5% of the total bid price, or for the amount specified in the proposal documents in effect on the date of invitation for bids whichever is the lesser sum. We bind ourselves, our heirs, executors, administrators, successors, and assigns, jointly pay to the LA this sum under the conditions of this instrument.

WHEREAS THE CONDITION OF THE FOREGOING OBLIGATION IS SUCH that, the said PRINCIPAL is submitting a written proposal to the LA acting through its awarding authority for the construction of the work designated as the above section.

THEREFORE if the proposal is accepted and a contract awarded to the PRINCIPAL by the LA for the above designated section and the PRINCIPAL shall within fifteen (15) days after award enter into a formal contract, furnish surety guaranteeing the faithful performance of the work, and furnish evidence of the required insurance coverage, all as provided in the "Standard Specifications for Road and Bridge Construction" and applicable Supplemental Specifications, then this obligation shall become void; otherwise it shall remain in full force and effect.

IN THE EVENT the LA determines the PRINCIPAL has failed to enter into a formal contract in compliance with any requirements set forth in the preceding paragraph, then the LA acting through its awarding authority shall immediately be entitled to recover the full penal sum set out above, together with all court costs, all attorney fees, and any other expense of recovery.

IN TESTIMONY WHEREOF, the said PRINCIPAL and the said SURETY have caused this instrument to be signed by their respective officers this _____ day of _____

Principal

 (Company Name) _____ (Company Name)

By: _____ By: _____
 (Signature and Title) (Signature and Title)

(If PRINCIPLE is a joint venture of two or more contractors, the company names, and authorized signatures of each contractor must be affixed.)

Surety

By: _____
 (Name of Surety) (Signature of Attorney-in-Fact)

STATE OF ILLINOIS,
 COUNTY OF _____

I, _____, a Notary Public in and for said county,
 do hereby certify that _____

(Insert names of individuals signing on behalf of PRINCIPAL & SURETY)

who are each personally known to me to be the same persons whose names are subscribed to the foregoing instrument on behalf of PRINCIPAL and SURETY, appeared before me this day in person and acknowledged respectively, that they signed and delivered said instruments as their free and voluntary act for the uses and purposes therein set forth.

Given under my hand and notarial seal this _____ day of _____

My commission expires _____
 (Notary Public)

ELECTRONIC BID BOND

Electronic bid bond is allowed (box must be checked by LA if electronic bid bond is allowed)

The Principal may submit an electronic bid bond, in lieu of completing the above section of the Proposal Bid Bond Form. By providing an electronic bid bond ID code and signing below, the Principal is ensuring the identified electronic bid bond has been executed and the Principal and Surety are firmly bound unto the LA under the conditions of the bid bond as shown above. (If PRINCIPAL is a joint venture of two or more contractors, an electronic bid bond ID code, company/Bidder name title and date must be affixed for each contractor in the venture.)

--	--	--	--	--	--	--	--	--	--

Electronic Bid Bond ID Code

 (Company/Bidder Name)

 (Signature and Title)

 Date

NOT FOR BID



Apprenticeship or Training Program Certification

Return with Bid

Route VARIOUS
County DUPAGE
Local Agency VILLA PARK
Section N/A

All contractors are required to complete the following certification:

- For this contract proposal or for all groups in this deliver and install proposal.
For the following deliver and install groups in this material proposal:

Blank lines for listing deliver and install groups.

Illinois Department of Transportation policy, adopted in accordance with the provisions of the Illinois Highway Code, requires this contract to be awarded to the lowest responsive and responsible bidder. The award decision is subject to approval by the Department. In addition to all other responsibility factors, this contract or deliver and install proposal requires all bidders and all bidders' subcontractors to disclose participation in apprenticeship or training programs that are (1) approved by and registered with the United States Department of Labor's Bureau of Apprenticeship and Training, and (2) applicable to the work of the above indicated proposals or groups. Therefore, all bidders are required to complete the following certification:

- I. Except as provided in paragraph IV below, the undersigned bidder certifies that it is a participant, either as an individual or as part of a group program, in an approved apprenticeship or training program applicable to each type of work or craft that the bidder will perform with its own employees.
II. The undersigned bidder further certifies for work to be performed by subcontract that each of its subcontractors submitted for approval either (A) is, at the time of such bid, participating in an approved, applicable apprenticeship or training program; or (B) will, prior to commencement of performance of work pursuant to this contract, establish participation in an approved apprenticeship or training program applicable to the work of the subcontract.
III. The undersigned bidder, by inclusion in the list in the space below, certifies the official name of each program sponsor holding the Certificate of Registration for all of the types of work or crafts in which the bidder is a participant and that will be performed with the bidder's employees. Types of work or craft that will be subcontracted shall be included and listed as subcontract work. The list shall also indicate any type of work or craft job category for which there is no applicable apprenticeship or training program available.

Blank lines for listing program sponsors and work/craft categories.

NOT FOR BID

IV. Except for any work identified above, any bidder or subcontractor that shall perform all or part of the work of the contract or deliver and install proposal solely by individual owners, partners or members and not by employees to whom the payment of prevailing rates of wages would be required, check the following box, and identify the owner/operator workforce and positions of ownership.

The requirements of this certification and disclosure are a material part of the contract, and the contractor shall require this certification provision to be included in all approved subcontracts. The bidder is responsible for making a complete report and shall make certain that each type of work or craft job category that will be utilized on the project is accounted for and listed. The Department at any time before or after award may require the production of a copy of each applicable Certificate of Registration issued by the United States Department of Labor evidencing such participation by the contractor and any or all of its subcontractors. In order to fulfill the participation requirement, it shall not be necessary that any applicable program sponsor be currently taking or that it will take applications for apprenticeship, training or employment during the performance of the work of this contract or deliver and install proposal.

Bidder: _____ By: _____ (Signature)
Address: _____ Title: _____

NOT FOR

NOT FOR BID



Affidavit of Illinois Business Office

County DUPAGE
Local Public Agency VILLA PARK
Section Number N/A
Route VARIOUS

State of)
County of) ss.

I, (Name of Affiant) of (City of Affiant), (State of Affiant),

being first duly sworn upon oath, states as follows:

- 1. That I am the officer or position of bidder.
2. That I have personal knowledge of the facts herein stated.
3. That, if selected under this proposal, (bidder), will maintain a business office in the State of Illinois which will be located in County, Illinois.
4. That this business office will serve as the primary place of employment for any persons employed in the construction contemplated by this proposal.
5. That this Affidavit is given as a requirement of state law as provided in Section 30-22(8) of the Illinois Procurement Code.

(Signature)
(Print Name of Affiant)

This instrument was acknowledged before me on day of , .

(SEAL)

(Signature of Notary Public)

NOT FOR BID



Illinois Department of Transportation

Bureau of Construction
2300 South Dirksen Parkway/Room 322
Springfield, Illinois 62764

Affidavit of Availability For the Letting of 8/28/2018

Instructions: Complete this form by either typing or using black ink. "Authorization to Bid" will not be issued unless both sides of this form are completed in detail. Use additional forms as needed to list all work.

Part I. Work Under Contract

List below all work you have under contract as either a prime contractor or a subcontractor. It is required to include all pending low bids not yet awarded or rejected. In a joint venture, list only that portion of the work which is the responsibility of your company. The uncompleted dollar value is to be based upon the most recent engineer's or owners estimate, and must include work subcontracted to others. If no work is contracted, show **NONE**.

	1	2	3	4	Awards Pending	
Contract Number						
Contract With						
Estimated Completion Date						
Total Contract Price						Accumulated Totals
Uncompleted Dollar Value if Firm is the Prime Contractor						
Uncompleted Dollar Value if Firm is the Subcontractor						
Total Value of All Work						

Part II. Awards Pending and Uncompleted Work to be done with your own forces.

List below the uncompleted dollar value of work for each contract and awards pending to be completed with your own forces. All work subcontracted to others will be listed on the reverse of this form. In a joint venture, list only that portion of the work to be done by your company. If no work is contracted, show **NONE**.

						Accumulated Totals
Earthwork						
Portland Cement Concrete Paving						
HMA Plant Mix						
HMA Paving						
Clean & Seal Cracks/Joints						
Aggregate Bases & Surfaces						
Highway, R.R. and Waterway Structures						
Drainage						
Electrical						
Cover and Seal Coats						
Concrete Construction						
Landscaping						
Fencing						
Guardrail						
Painting						
Signing						
Cold Milling, Planning & Rotomilling						
Demolition						
Pavement Markings (Paint)						
Other Construction (List)						
						\$ 0.00
Totals						

Disclosure of this information is **REQUIRED** to accomplish the statutory purpose as outlined in the "Illinois Procurement Code." Failure to comply will result in non-issuance of an "Authorization To Bid." This form has been approved by the State Forms Management Center.

NOT FOR BID

Part III. Work Subcontracted to Others.

For each contract described in Part I, list all the work you have subcontracted to others.

	1	2	3	4	Awards Pending
Subcontractor					
Type of Work					
Subcontract Price					
Amount Uncompleted					
Subcontractor					
Type of Work					
Subcontract Price					
Amount Uncompleted					
Subcontractor					
Type of Work					
Subcontract Price					
Amount Uncompleted					
Subcontractor					
Type of Work					
Subcontract Price					
Amount Uncompleted					
Subcontractor					
Type of Work					
Subcontract Price					
Amount Uncompleted					
Total Uncompleted					

I, being duly sworn, do hereby declare that this affidavit is a true and correct statement relating to ALL uncompleted contracts of the undersigned for Federal, State, County, City and private work, including ALL subcontract work, ALL pending low bids not yet awarded or rejected and ALL estimated completion dates.

Subscribed and sworn to before me
 this _____ day of _____, _____ Type or Print Name _____
 Officer or Director Title

Signed _____

Notary Public

My commission expires _____

(Notary Seal)

Company _____

Address _____

NOT FOR BID



PROPOSAL SUBMITTED BY		
Contractor's Name		
Street	P.O. Box	
City	State	Zip Code

STATE OF ILLINOIS

COUNTY DUPAGE
VILLA PARK
(Name of City, Village, Town or Road District)

FOR THE IMPROVEMENT OF
STREET NAME OR ROUTE VARIOUS
SECTION NO. N/A
TYPES OF FUNDS LOCAL

- SPECIFICATIONS (required) PLANS (required) CONTRACT BOND (when required)

NOT FOR BID

NOT FOR BID

County DUPAGE
Local Public Agency VILLA PARK
Section Number N/A
Route VARIOUS

1. THIS AGREEMENT, made and concluded the _____ day of _____, _____
Month and Year
between the Village of Villa Park
acting by and through its Board of Trustees known as the party of the first part, and
_____ his/their executors, administrators, successors or assigns,
known as the party of the second part.

2. Witnesseth: That for and in consideration of the payments and agreements mentioned in the Proposal hereto attached, to be made and performed by the party of the first part, and according to the terms expressed in the Bond referring to these presents, the party of the second part agrees with said party of the first part at his/their own proper cost and expense to do all the work, furnish all materials and all labor necessary to complete the work in accordance with the plans and specifications hereinafter described, and in full compliance with all of the terms of this agreement and the requirements of the Engineer under it.

3. And it is also understood and agreed that the LPA Formal Contract Proposal, Special Provisions, Affidavit of Illinois Business Office, Apprenticeship or Training Program Certification, and Contract Bond hereto attached, and the Plans for Section N/A, in Village of Villa Park, approved by the Illinois Department of Transportation on _____, are essential documents of this contract and are a part hereof.
Date

4. IN WITNESS WHEREOF, The said parties have executed these presents on the date above mentioned.

Attest: _____ The Village of Villa Park
Clerk By _____
Party of the First Part
(Seal) _____
(If a Corporation)

Corporate Name _____
By _____
President Party of the Second Part
(If a Co-Partnership)

Attest: _____
Secretary

Partners doing Business under the firm name of _____
Party of the Second Part
(If an individual)
_____ Party of the Second Part

NOT FOR BID



Route VARIOUS
 County DUPAGE
 Local Agency VILLA PARK
 Section N/A

We , _____

a/an) Individual Co-partnership Corporation organized under the laws of the State of _____ ,
as PRINCIPAL, and _____

_____ as SURETY,

are held and firmly bound unto the above Local Agency (hereafter referred to as "LA") in the penal sum of _____

_____ Dollars (_____), lawful money of the

United States, well and truly to be paid unto said LA, for the payment of which we bind ourselves, our heirs, executors, administrators, successors, jointly to pay to the LA this sum under the conditions of this instrument.

WHEREAS THE CONDITION OF THE FOREGOING OBLIGATION IS SUCH that, the said Principal has entered into a written contract with the LA acting through its awarding authority for the construction of work on the above section, which contract is hereby referred to and made a part hereof, as if written herein at length, and whereby the said Principal has promised and agreed to perform said work in accordance with the terms of said contract, and has promised to pay all sums of money due for any labor, materials, apparatus, fixtures or machinery furnished to such Principal for the purpose of performing such work and has further agreed to pay all direct and indirect damages to any person, firm, company or corporation suffered or sustained on account of the performance of such work during the time thereof and until such work is completed and accepted; and has further agreed that this bond shall inure to the benefit of any person, firm, company or corporation to whom any money may be due from the Principal, subcontractor or otherwise for any such labor, materials, apparatus, fixtures or machinery so furnished and that suit may be maintained on such bond by any such person, firm, company or corporation for the recovery of any such money.

NOW THEREFORE, if the said Principal shall well and truly perform said work in accordance with the terms of said contract, and shall pay all sums of money due or to become due for any labor, materials, apparatus, fixtures or machinery furnished to him for the purpose of constructing such work, and shall commence and complete the work within the time prescribed in said contract, and shall pay and discharge all damages, direct and indirect, that may be suffered or sustained on account of such work during the time of the performance thereof and until the said work shall have been accepted, and shall hold the LA and its awarding authority harmless on account of any such damages and shall in all respects fully and faithfully comply with all the provisions, conditions and requirements of said contract, then this obligation to be void; otherwise to remain in full force and effect.

NOT FOR BID

IN TESTIMONY WHEREOF, the said PRINCIPAL and the said SURETY have caused this instrument to be signed by their respective officers this _____ day of _____ A.D. _____

PRINCIPAL

(Company Name)

(Company Name)

By: _____
(Signature & Title)

By: _____
(Signature & Title)

Attest: _____
(Signature & Title)

Attest: _____
(Signature & Title)

(If PRINCIPAL is a joint venture of two or more contractors, the company names and authorized signature of each contractor must be affixed.)

STATE OF ILLINOIS,

COUNTY OF _____

I, _____, a Notary Public in and for said county, do hereby certify that

(Insert names of individuals signing on behalf or PRINCIPAL)

who are each personally known to me to be the same persons whose names are subscribed to the foregoing instrument on behalf of PRINCIPAL, appeared before me this day in person and acknowledged respectively, that they signed and delivered said instrument as their free and voluntary act for the uses and purposes therein set forth.

Given under my hand and notarial seal this _____ day of _____ A.D. _____

My commission expires _____ Notary Public (SEAL)

SURETY

(Name of Surety)

By: _____
(Signature of Attorney-in-Fact)

STATE OF ILLINOIS.

(SEAL)

COUNTY OF _____

I, _____, a Notary Public in and for said county, do hereby certify that

(Insert names of individuals signing on behalf or SURETY)

who are each personally known to me to be the same persons whose names are subscribed to the foregoing instrument on behalf of SURETY, appeared before me this day in person and acknowledged respectively, that they signed and delivered said instrument as their free and voluntary act for the uses and purposes therein set forth.

Given under my hand and notarial seal this _____ day of _____ A.D. _____

My commission expires _____ Notary Public (SEAL)

Approved this _____ day of _____, A.D. 2018

Attest: _____

Village of Villa Park
(Awarding Authority)

Village Clerk

(Chairman/Mayor/President)

NOT FOR BID

INDEX
FOR
SUPPLEMENTAL SPECIFICATIONS
AND RECURRING SPECIAL PROVISIONS

Adopted January 1, 2018

This index contains a listing of SUPPLEMENTAL SPECIFICATIONS, frequently used RECURRING SPECIAL PROVISIONS, and LOCAL ROADS AND STREETS RECURRING SPECIAL PROVISIONS.

ERRATA Standard Specifications for Road and Bridge Construction
(Adopted 4-1-16) (Revised 1-1-18)

SUPPLEMENTAL SPECIFICATIONS

<u>Std. Spec. Sec.</u>		<u>Page No.</u>
106	Control of Materials	1
403	Bituminous Surface Treatment (Class A-1, A-2, A-3)	2
404	Micro-Surfacing and Slurry Sealing	3
405	Cape Seal	14
420	Portland Cement Concrete Pavement	24
442	Pavement Patching	26
502	Excavation for Structures	27
503	Concrete Structures	29
504	Precast Concrete Structures	32
542	Pipe Culverts	33
586	Sand Backfill for Vaulted Abutments	34
630	Steel Plate Beam Guardrail	36
631	Traffic Barrier Terminals	39
670	Engineer's Field Office and Laboratory	40
701	Work Zone Traffic Control and Protection	41
704	Temporary Concrete Barrier	42
781	Raised Reflective Pavement Markers	44
888	Pedestrian Push-Button	45
1003	Fine Aggregates	46
1004	Coarse Aggregates	47
1006	Metals	50
1020	Portland Cement Concrete	51
1050	Poured Joint Sealers	53
1069	Pole and Tower	55
1077	Post and Foundation	56
1096	Pavement Markers	57
1101	General Equipment	58
1102	Hot-Mix Asphalt Equipment	59
1103	Portland Cement Concrete Equipment	61
1106	Work Zone Traffic Control Devices	63



The Following Recurring Special Provisions Indicated By An "X" Are Applicable To This Contract And Are Included By Reference:

Recurring Special Provisions

<u>Check Sheet #</u>		<u>Page No.</u>
1	<input type="checkbox"/> Additional State Requirements for Federal-Aid Construction Contracts	64
2	<input type="checkbox"/> Subletting of Contracts (Federal-Aid Contracts)	67
3	<input type="checkbox"/> EEO	68
4	<input type="checkbox"/> Specific EEO Responsibilities Non Federal-Aid Contracts	78
5	<input type="checkbox"/> Required Provisions - State Contracts	83
6	<input type="checkbox"/> Asbestos Bearing Pad Removal	89
7	<input type="checkbox"/> Asbestos Waterproofing Membrane and Asbestos Hot-Mix Asphalt Surface Removal	90
8	<input type="checkbox"/> Temporary Stream Crossings and In-Stream Work Pads	91
9	<input type="checkbox"/> Construction Layout Stakes Except for Bridges	92
10	<input checked="" type="checkbox"/> Construction Layout Stakes	95
11	<input type="checkbox"/> Use of Geotextile Fabric for Railroad Crossing	98
12	<input type="checkbox"/> Subsealing of Concrete Pavements	100
13	<input type="checkbox"/> Hot-Mix Asphalt Surface Correction	104
14	<input type="checkbox"/> Pavement and Shoulder Resurfacing	106
15	<input type="checkbox"/> Patching with Hot-Mix Asphalt Overlay Removal	107
16	<input type="checkbox"/> Polymer Concrete	109
17	<input type="checkbox"/> PVC Pipeliner	111
18	<input type="checkbox"/> Bicycle Racks	112
19	<input type="checkbox"/> Temporary Portable Bridge Traffic Signals	114
20	<input type="checkbox"/> Work Zone Public Information Signs	116
21	<input type="checkbox"/> Nighttime Inspection of Roadway Lighting	117
22	<input type="checkbox"/> English Substitution of Metric Bolts	118
23	<input type="checkbox"/> Calcium Chloride Accelerator for Portland Cement Concrete	119
24	<input type="checkbox"/> Quality Control of Concrete Mixtures at the Plant	120
25	<input checked="" type="checkbox"/> Quality Control/Quality Assurance of Concrete Mixtures	128
26	<input type="checkbox"/> Digital Terrain Modeling for Earthwork Calculations	144
27	<input type="checkbox"/> Reserved	146
28	<input type="checkbox"/> Preventive Maintenance - Bituminous Surface Treatment	147
29	<input type="checkbox"/> Reserved	153
30	<input type="checkbox"/> Reserved	154
31	<input type="checkbox"/> Reserved	155
32	<input type="checkbox"/> Temporary Raised Pavement Markers	156
33	<input type="checkbox"/> Restoring Bridge Approach Pavements Using High-Density Foam	157
34	<input type="checkbox"/> Portland Cement Concrete Inlay or Overlay	160
35	<input type="checkbox"/> Portland Cement Concrete Partial Depth Hot-Mix Asphalt Patching	164

The Following Local Roads And Streets Recurring Special Provisions Indicated By An "X" Are Applicable To This Contract And Are Included By Reference:

Local Roads And Streets Recurring Special Provisions

<u>Check Sheet #</u>		<u>Page No.</u>
LRS 1	Reserved	168
LRS 2	<input type="checkbox"/> Furnished Excavation	169
LRS 3	<input checked="" type="checkbox"/> Work Zone Traffic Control Surveillance	170
LRS 4	<input checked="" type="checkbox"/> Flaggers in Work Zones	171
LRS 5	<input checked="" type="checkbox"/> Contract Claims	172
LRS 6	<input type="checkbox"/> Bidding Requirements and Conditions for Contract Proposals	173
LRS 7	<input type="checkbox"/> Bidding Requirements and Conditions for Material Proposals	179
LRS 8	Reserved	185
LRS 9	<input type="checkbox"/> Bituminous Surface Treatments	186
LRS 10	Reserved	187
LRS 11	<input type="checkbox"/> Employment Practices	188
LRS 12	<input checked="" type="checkbox"/> Wages of Employees on Public Works	190
LRS 13	<input type="checkbox"/> Selection of Labor	192
LRS 14	<input type="checkbox"/> Paving Brick and Concrete Paver Pavements and Sidewalks	193
LRS 15	<input checked="" type="checkbox"/> Partial Payments	196
LRS 16	<input checked="" type="checkbox"/> Protests on Local Lettings	197
LRS 17	<input checked="" type="checkbox"/> Substance Abuse Prevention Program	198
LRS 18	<input type="checkbox"/> Multigrade Cold Mix Asphalt	199

NOT FOR BIDDING

NOT FOR BID

INDEX OF SPECIAL PROVISIONS

TITLE	PAGE NO.
DEFINITIONS.....	1
LOCATION OF PROJECT.....	1
DESCRIPTION OF PROJECT.....	2
PROJECT SCHEDULE AND COMPLETION.....	2
GENERAL SPECIAL PROVISIONS.....	3
QUALIFICATIONS OF BIDDERS.....	3
BID PRICE LIMITATIONS.....	6
BIDS TO REMAIN SUBJECT TO ACCEPTANCE.....	6
AWARD OF CONTRACT.....	6
SUBCONTRACTORS.....	7
INSURANCE.....	7
INCREASED OR DECREASED QUANTITIES.....	7
MOBILIZATION.....	7
PORTABLE TOILET.....	8
WORKING HOURS.....	8
HOLIDAYS.....	8
PUBLIC CONVENIENCE AND SAFETY (D-1).....	9
OPERATION OF WATER DISTRIBUTION FACILITIES.....	9
CONSTRUCTION SAFETY AND HEALTH STANDARDS.....	9
FINAL INSPECTION.....	10
MAINTENANCE WARRANTY.....	10
MAINTENANCE OF ROADWAYS.....	11
KEEPING ROADS OPEN TO TRAFFIC.....	11
RESPONSIBILITY FOR VANDALISM.....	11
USE OF FIRE HYDRANTS.....	12
TRENCH BACKFILL AND PIPE BEDDING.....	13

**2018 STREET IMPROVEMENTS
VILLAGE OF VILLA PARK**

EXCAVATION AND BACKFILLING OF DRAINAGE AND UTILITY STRUCTURES.....	13
SALVAGE AND DISPOSAL OF EXISTING MATERIALS.....	13
FRAMES, GRATES AND LIDS.....	14
DATE OF MANUFACTURE.....	15
IRON AND STEEL MATERIALS.....	15
PROTECTION OF EXISTING DRAINAGE FACILITIES DURING CONSTRUCTION.....	15
EXISTING SEWER REMOVAL.....	16
PLUGGING EXISTING MANHOLES AND PIPES.....	16
IEPA CLEAN CONSTRUCTION AND DEMOLITION DEBRIS (CCDD).....	17
PAVEMENT CORES AND WASTE DISPOSAL REPORTS.....	17
MATERIAL AND EQUIPMENT STORAGE.....	17
CONSTRUCTION NOTICES.....	17
PAY ITEM SPECIAL PROVISIONS.....	19
PAY ITEM #3 – TREE TRUNK PROTECTION.....	19
PAY ITEM #4 – TREE ROOT PRUNING.....	19
PAY ITEM #5 – TREE PRUNING.....	19
PAY ITEM #8 – TRENCH BACKFILL.....	20
PAY ITEM #9 – GEOTECHNICAL FABRIC FOR GROUND STABILIZATION.....	20
PAY ITEM #10 – SODDING.....	20
PAY ITEM #12 – INLET FILTERS.....	21
PAY ITEM #14 – BITUMINOUS MATERIALS (TACK COAT).....	21
PAY ITEM #17/18 – PORTLAND CEMENT CONCRETE DRIVEWAY PAVEMENT.....	22
PAY ITEM #19/20 – PORTLAND CEMENT CONCRETE SIDEWALK.....	22
PAY ITEM #21 – DETECTABLE WARNINGS.....	23
PAY ITEM #22 – PAVEMENT REMOVAL.....	24
PAY ITEM #24 – DRIVEWAY PAVEMENT REMOVAL.....	24
PAY ITEM #25 – CURB REMOVAL.....	25
PAY ITEM #26 – COMBINATION CURB AND GUTTER REMOVAL.....	25
PAY ITEM #27 – SIDEWALK REMOVAL.....	26

**2018 STREET IMPROVEMENTS
VILLAGE OF VILLA PARK**

PAY ITEM #28 – AGGREGATE SHOULDER, TYPE A.....	26
PAY ITEM #29 – DOMESTIC WATER SERVICE BOXES TO BE ADJUSTED.....	26
PAY ITEM #30 – CATCH BASIN, TYPE C.....	27
PAY ITEM #31 – INLETS, TYPE A.....	28
PAY ITEM #36 – CONCRETE CURB, TYPE B.....	28
PAY ITEM #37/38 – COMBINATION CONCRETE CURB AND GUTTER.....	30
PAY ITEM #45 – EXPLORATION TRENCH, SPECIAL.....	32
PAY ITEM #46/47/48 – TEMPORARY ACCESS.....	32
PAY ITEM #49 – TRAFFIC CONTROL AND PROTECTION (SPECIAL).....	33
PAY ITEM #51 – DRAINAGE & UTILITY STRUCTURES TO BE ADJUSTED.....	34
PAY ITEM #52 – DRAINAGE & UTILITY STRUCTURES TO BE RECONSTRUCTED.....	34
PAY ITEM #53/54 – HOT-MIX ASPHALT DRIVEWAY PAVEMENT.....	35
PAY ITEM #55 – BRICK DRIVEWAY REMOVAL AND REPLACEMENT.....	35
PAY ITEM #56 – BRICK PAVER REMOVAL.....	36
PAY ITEM #57 – STRUCTURE TO BE REMOVED.....	37
PAY ITEM #58 – STORM SEWERS, CLASS B (PVC), 6”.....	37
PAY ITEM #59 – SANITARY MANHOLE, TYPE A, 4’-DIAMETER, TYPE 1 FRAME, CLOSED LID.....	38
PAY ITEM #60 – SANITARY SERVICE CONNECTION.....	38
PAY ITEM #61 – SANITARY SERVICE REPLACEMENT.....	39
PAY ITEM #62 – SANITARY SEWER SERVICE COMBINATION CLEANOUT CHECK VALVE.....	40
PAY ITEM #63/64 – WATER SERVICE CONNECTION.....	41
PAY ITEM #65 – WATER USAGE CREDIT.....	43
PAY ITEM #66 – WATER USAGE DEDUCTION.....	44
PAY ITEM #67 – PRE-CONSTRUCTION VIDEO RECORDING.....	44
PAY ITEM #68 – CONTINGENCY ALLOWANCE.....	47
ADJUSTMENTS AND RECONSTRUCTIONS.....	49
FRICITION AGGREGATE (D-1).....	50
GROUND TIRE RUBBER (GTR) MODIFIED ASPHALT BINDER (D-1).....	53
HMA MIXTURE REQUIREMENTS (D-1).....	54

RECLAIMED ASPHALT PAVEMENT AND RECLAIMED ASPHALT SHINGLES

(D-1).....62

BDE SPECIAL PROVISIONS

LR 102-2

LR 105

LR 107-4

LR 107-7

LR 109

HIGHWAY STANDARDS

APPENDIX A – PREVAILING WAGE RATES

APPENDIX B – IRMA CONTRACTUAL INSURANCE GUIDELINES

APPENDIX C – VILLAGE OF VILLA PARK ORDINANCE 3733

NOT FOR BID

SPECIAL PROVISIONS

The following Special Provisions supplement the “Standard Specifications for Road and Bridge Construction”, adopted April 1, 2016 (referred to hereinafter as the Standard Specifications); the “Supplemental Specifications and Recurring Special Provisions”, adopted January 1, 2018; the latest edition of the “Illinois Manual on Uniform Traffic Control Devices For Streets and Highways” (IMUTCD); and the “Standard Specifications for Water and Sewer Construction in Illinois”, 7th Edition, 2014 (referred to hereinafter as the Water and Sewer Specifications). In case of conflict with any part or parts of said Specifications, these Special Provisions shall take precedence and shall govern. Where no conflict exists, the said Specifications shall apply to this Contract as if repeated in their entirety herein.

DEFINITIONS

Contractor. The individual, firm, partnership, joint venture, or corporation contracting with the Village of Villa Park for performance of prescribed work.

Department, Owner or Village. The Village of Villa Park, DuPage County, Illinois.

Engineer. The Resident Engineer who is the authorized representative of the Village of Villa Park in immediate charge of the engineering details of a construction project.

LOCATION OF PROJECT

The proposed improvements are located at the following locations in the Village of Villa Park:

Street/Location

Base Bid

Euclid Avenue
Second Avenue
Biermann Avenue
Holly Court

Alternate 1 & 2

Villa Park Public Works Parking Lot

Alternate 3

Villa Park Fire Department

Alternate 4

Sugar Creek Golf Course Parking Lot

Limits

St. Charles Road to Division Street
St. Charles Road to Holly Court
St. Charles Road to Division Street
Westmore Avenue to Addison Road

11 W. Home Avenue

1440 Ardmore Avenue

500 E. Van Buren Street

DESCRIPTION OF PROJECT

The base bid for this project consists of roadway pavement reconstruction at various locations throughout the Village. The project includes pavement removal, aggregate base course, Hot-Mix Asphalt Binder Course, Hot-Mix Asphalt Surface Course, curb and gutter removal and replacement, sidewalk removal and replacement, driveway pavement removal and replacement, drainage and utility structure adjustments, and landscape restoration.

The project will also include four alternate bids. Alternates 1 and 2 consist of the reconstruction of the Villa Park Public Works parking lot with either Hot-Mix Asphalt pavement or Portland Cement Concrete pavement, respectively. Alternate 3 consists of the removal and replacement of the Portland Cement Concrete driveway at the Villa Park Fire Station. Alternate 4 consists of the reconstruction of the southwest corner of the Sugar Creek Golf Course parking lot with Hot-Mix Asphalt pavement.

PROJECT SCHEDULE AND COMPLETION

Once the CONTRACTOR starts work at a particular project location, he/she has the following calendar days to complete the work on that street:

Base Bid

Euclid Avenue	28 Calendar Days
Second Avenue	21 Calendar Days
Biermann Avenue	28 Calendar Days
Holly Court	28 Calendar Days

Alternate 1 & 2

Villa Park Public Works Parking Lot	21 Calendar Days
-------------------------------------	------------------

Alternate 3

Villa Park Fire Department	14 Calendar Days
----------------------------	------------------

Alternate 4

Sugar Creek Golf Course Parking Lot	14 Calendar Days
-------------------------------------	------------------

All contract work, not including punch list items, needs to be completed within 60 calendar days of the Notice to Proceed.

The CONTRACTOR shall coordinate schedules with the Village of Villa Park Fire Department, Public Works Department, and the Sugar Creek Golf Course prior to construction. The CONTRACTOR shall work to maintain access to these facilities whenever possible.

GENERAL SPECIAL PROVISIONS

QUALIFICATIONS OF BIDDERS

Bidders will comply with all applicable Federal, State and local laws and requirements, and will further meet the qualifications prescribed in this and other applicable portions of these provisions.

Bidder, in submitting a Bid, certifies that Bidder is in compliance with all applicable Federal, State and local laws and requirements, and that Bidder further meets the qualifications prescribed in this and other applicable portions of these provisions. Engineer's determination as to the compliance and qualifications of the Bidder will be final, and Bidder, in submitting a Bid, agrees to be bound by that determination.

Bidder, in submitting a Bid, certifies that Bidder is in compliance with the following requirements and qualifications. Bidder further certifies that Bidder is able to provide written evidence of Bidder's compliance with the following requirements and qualifications. Bidder shall, upon request by Engineer, submit such written evidence within five (5) calendar days of the Engineer's request, as well as any other written evidence which Engineer may deem necessary for the purpose of evaluating Bidder's qualifications.

- (a) Bidder shall be qualified to do business in the State of Illinois.
- (b) Bidder shall possess either a valid Federal Employer Tax Identification Number (FEIN) or a valid Social Security Number (SSN).
- (c) Bidder shall be able to provide a street address and description of the Bidder's place of business, and the mailing address of the business, if different from the street address.
- (d) Bidder shall be able to provide the number of years Bidder has been engaged in the contracting business under the present firm name, and the name of the state where incorporated.
- (e) Bidder shall be able to provide a list of the property and equipment available to the Bidder.
- (f) Bidder shall be able to provide a financial statement demonstrating that the Bidder has the financial resources to meet all obligations related to the Work.
- (g) Bidder shall maintain insurance policies with the coverages required by the Contract, and with the minimum limits of coverage required by the Contract. Bidder shall be able to provide current certificate(s) of insurance for the

**2018 STREET IMPROVEMENTS
VILLAGE OF VILLA PARK**

insurance policies held by Bidder, demonstrating that Bidder holds insurance policies with the coverages required by the contract, and with the minimum limits of coverage required by the Contract.

- (h) Bidder shall have constructed a minimum of three (3) projects of a similar nature in the immediate past five (5) years. Bidder shall be able to provide a list of all projects of a similar nature constructed by Bidder in the immediate past five (5) years, which list shall contain the minimum of three (3) such projects, which list shall provide a description and the location(s) of all such projects, and shall contain the Bidder's performance record and references, as well as the names and current contact information, including addresses and telephone numbers, of persons who acted as owners' representatives for those projects and who have knowledge of those projects, and whom Bidder agrees the Village may contact for the purpose of verifying Bidder's performance and references.
- (i) Bidder shall be able to provide a list of three (3) references (name, address and telephone number) with knowledge of the integrity and business practices of the bidder. Such references may not be persons who have been employed by Bidder as employees.
- (j) Bidder shall be able to provide a list of projects presently under Contract, the awarded Contract amount of each, the approximate adjusted Contract amount of each (if applicable), and the dollar amount or percent of completion of each.
- (k) Bidder shall be able to provide a list of Contracts which have resulted in lawsuits, whether against Bidder as a prime contractor, against Bidder as a subcontractor, or against Bidder as a party in any other capacity; or against subcontractors or suppliers performing work for Bidder or under Contract held by Bidder.
- (l) Bidder shall be able to provide a list of Contracts defaulted.
- (m) Bidder shall be able to provide a statement indicating whether or not Bidder has ever filed bankruptcy.
- (n) Bidder shall be able to provide a list of all officers of the firm, which list shall also indicate those officers who, while in the employ of the firm or in the employ of previous firms, were associated with Contracts which resulted in lawsuits, Contracts defaulted, or firms which filed for bankruptcy.
- (o) Bidder shall maintain personnel guaranteed to be employed in the responsible charge of the Work, which personnel possess sufficient technical experience to ensure the satisfactory completion of the Work. Bidder shall be

**2018 STREET IMPROVEMENTS
VILLAGE OF VILLA PARK**

able to provide the names and technical experience of such personnel, as well as statements as to whether the personnel have or have not performed satisfactorily on other contracts of like nature and magnitude or comparable difficulty at similar rate of progress.

- (p) Bidder shall be able to provide a list of subcontractors and suppliers anticipated to be employed by Bidder for the purpose of completing the Work, including the firm name, street address and description of place of business; mailing address of business (if different); phone, fax and e-mail contact information of business; name of primary contact; and a list of any projects or contracts for which Bidder currently owes monies to said firm, which list shall include a description of the project or contract, the amount currently due to said firm, the period of time for which those monies have been owed, and the expected date of payment of those monies.
- (q) Bidder shall participate in active apprenticeship and training programs approved by and registered with the United States Department of Labor Bureau of Apprenticeship and Training for each of the trades of work contemplated under the Contract. Bidder shall be able to provide evidence of Bidder's participation in such apprenticeship and training programs.
- (r) Bidder shall only employ subcontractors who meet the requirements prescribed in this section and other sections of these specifications.
- (s) Bidder shall be able to provide such other information as may assist the Village in determining whether the Bidder is adequately prepared to fulfill the Contract.

These requirements and qualifications are not intended to discourage bidding, to make it difficult for qualified Bidders to submit Bids, or to discourage beginning contractors. The purpose of these requirements and qualifications is to allow the Village to obtain sufficient information about Bidder's financial state, available equipment, personnel, and previous work experience so that the Village may mitigate the hazards involved in awarding contracts to parties who may not be qualified to perform the Work as specified.

A copy of Village of Villa Park Ordinance No. 3733, amending the requirements of bidders for construction projects, is provided as Appendix C.

BID PRICE LIMITATIONS

The bid price for TRAFFIC CONTROL AND PROTECTION shall not exceed 5 percent of the total bid price. If the bid price for TRAFFIC CONTROL AND PROTECTION exceeds 5 percent of the total bid price, the Village may reject the Bid.

The bid price for CONSTRUCTION LAYOUT shall not exceed 2 percent of the total bid price. If the bid price for CONSTRUCTION LAYOUT exceeds 2 percent of the total bid price, the Village may reject the Bid.

The bid price for PRE-CONSTRUCTION VIDEO RECORDING shall not exceed 1 percent of the total bid price. If the bid price for PRE-CONSTRUCTION VIDEO RECORDING exceeds 1 percent of the total bid price, the Village may reject the Bid.

Bidder, in submitting a Bid, certifies that the Bid is in compliance with these requirements. The Village's determination as to whether or not to reject a Bid that does not comply with these requirements will be final, and Bidder, in submitting a Bid, agrees to be bound by that determination.

BIDS TO REMAIN SUBJECT TO ACCEPTANCE

All bids shall remain subject to acceptance by the Village for a period of 60 calendar days from the date of the bid opening. The Village may extend the acceptance period by up to an additional 60 calendar days upon written notice to all bidders by the Village. The Village may, in its sole discretion, release any bid and return the bid bond prior to the end of the acceptance period.

AWARD OF CONTRACT

The Village of Villa Park reserves the right to award the contract to the lowest responsible Bidder for the Base Bid or for the Base Bid plus any combination of the Alternate(s), based upon the Village's best interest. Providing the lowest bid on the Base Bid or an individual Bid Alternate does not guarantee the Contractor will be awarded the contract, as the Contractor will need to be the lowest bidder on the combination of the Base Bid and Bid Alternates that the Village ultimately selects at its own discretion.

Each Bidder must submit bids for the Base Bid and all Alternates to be eligible for the award of the contract. Failure to do so may result in rejection of the CONTRACTOR's bid.

SUBCONTRACTORS

Add the following paragraph to the end of Article 108.01 of the Standard Specifications:

“The apparent low Bidder shall submit to the Village within 7 calendar days after the receipt of bids, a list of the names of Bidder’s proposed subcontractors and material suppliers along with a description of the work to be performed or the materials to be supplied by each.”

INSURANCE

Insurance and indemnification shall be in accordance with applicable sections of the Standard Specifications, and shall also be in accordance with the “IRMA Contractual Insurance Guidelines”, incorporated herein as Appendix B. The Contractor shall name the Village of Villa Park, its officials, agents, employees and volunteers as additional insureds. If a conflict is determined to exist between the requirements prescribed in the Standard Specifications and the requirements prescribed in the IRMA Contractual Insurance Guidelines, such conflict will be resolved as follows:

- a. If a particular type of insurance coverage is required by one standard but not by both, that type of insurance coverage will be required.
- b. If the minimum limits of insurance coverage required by one standard differ from those required by the other standard, the higher minimum limits of insurance coverage will prevail.
- c. If any other conflicts are determined to exist between the requirements prescribed in the two standards, the stricter of the two requirements will prevail. The Village will make the final determination as to what constitutes a stricter requirement.

INCREASED OR DECREASED QUANTITIES

The Village reserves the right to increase or decrease the amount of work shown in the plans in accordance with Section 109 of the Standard Specifications.

MOBILIZATION

Mobilization shall be in accordance with Section 671 of the Standard Specifications, except as modified herein.

Revise Article 671.02, Basis of Payment, to read:

2018 STREET IMPROVEMENTS VILLAGE OF VILLA PARK

“671.02 Basis of Payment. This work will not be paid for separately but shall be included in the unit bid prices of the items for which this work applies.”

PORTABLE TOILET

Contractor shall furnish a portable toilet meeting Federal, State and local health department requirements stocked with lavatory and sanitary supplies at all times. The portable toilet shall be provided at a location approved by the Engineer. The portable toilet shall be maintained in a clean and sanitary condition and shall be emptied as needed. This work will not be paid for separately but shall be included in the cost of the contract.

WORKING HOURS

Working hours will be between 7:00 A.M. and 5:00 P.M., Monday through Friday, excluding holidays as designated by the Contract.

Contractor will not permit the performance of Work outside these working hours without Owner's written consent, which may be given after prior written request to Engineer, except as otherwise required for the safety of persons or the Work or property at the Site or adjacent thereto, and except as otherwise stated in the Contract Documents.

If Contractor permits the performance of Work outside these working hours, Contractor will compensate Owner for the costs of inspection and other services provided by Engineer. Owner will determine the rates at which such inspection and other services are to be compensated. Owner will determine the interval or intervals at which billing will take place, and may, at Owner's discretion, submit invoices for payment to Contractor, or deduct the costs from any monies due or to become due to the Contractor from Owner.

HOLIDAYS

Revise the list of legal holidays in Article 107.09 of the Standard Specifications to read:

New Year's Day
Easter
Memorial Day
Independence Day
Labor Day

Thanksgiving Day
Thanksgiving Friday
Christmas Eve
Christmas Day
New Year's Eve

PUBLIC CONVENIENCE AND SAFETY (D-1)

Effective: May 1, 2012
Revised: July 15, 2012

Add the following to the end of the fourth paragraph of Article 107.09:

“If the holiday is on a Saturday or Sunday, and is legally observed on a Friday or Monday, the length of Holiday Period for Monday or Friday shall apply.”

Add the following sentence after the Holiday Period table in the fourth paragraph of Article 107.09:

“The Length of Holiday Period for Thanksgiving shall be from 5:00 AM the Wednesday prior to 11:59 PM the Sunday After”

Delete the fifth paragraph of Article 107.09 of the Standard Specifications:

“On weekends, excluding holidays, on roadways with Average Daily Traffic of 25,000 or greater, all lanes shall be open to traffic from 3:00 P.M. Friday to midnight Sunday except where structure construction or major rehabilitation makes it impractical.”

OPERATION OF WATER DISTRIBUTION FACILITIES

Contractor shall not operate any water distribution facilities, including, but not limited to, valves or hydrants. If Contractor requires the operation of such facilities, Contractor shall provide a minimum of 48 hours notice to the Village and the Village will operate such facilities.

CONSTRUCTION SAFETY AND HEALTH STANDARDS

It is a condition of this contract and shall be made a condition of each subcontract entered into pursuant to this contract that the Contractor and any Subcontractor shall not require any laborer or mechanic employed in performance of that contract to work in surroundings or under working conditions which are unsanitary, hazardous or dangerous to their health or safety, as determined under Federal Construction Safety and Health Standards.

FINAL INSPECTION

Final inspection shall be in accordance with Article 105.13 of the Standard Specifications, except as modified herein.

Revise the second paragraph of Article 105.13, Final Inspection, to read:

“If the inspection discloses any work, in whole or in part, as being unsatisfactory, the Engineer will give the Contractor the necessary instructions for correction of same, and the Contractor shall comply with such instructions within 14 calendar days of receipt of such instructions. The Contractor shall give the Engineer not less than 48 hours notice, in writing, prior to beginning any such corrective work. Upon completion of all corrective work, the Contractor shall give the Engineer notice in writing. Upon receipt of such notice, the Engineer will make another inspection which shall constitute the final inspection provided the work has been satisfactorily completed. In such event, the Engineer will notify the Contractor in writing of the date of final inspection.”

MAINTENANCE WARRANTY

The Contractor shall execute and deliver to the Village, before final payment will be issued, a written warranty, in a form satisfactory to the Village, which guarantees that all work is in accordance with the contract and will not be defective. This warranty shall guarantee all work for a period of 1 year from the date of final inspection.

The Contractor shall furnish a warranty bond in an amount equal to 10 percent of the final contract amount, or \$150,000, whichever is greater, by a surety satisfactory to the Village to guarantee Contractor's warranty to repair defective work.

If, within the warranty period, the Village determines any work to be defective, a written notice of such deficiency will be sent to the Contractor by certified mail.

The Contractor shall, within 14 calendar days of receipt of the notice of deficiency, and without cost to the Village, correct or repair such defective work, or remove and replace the defective work in accordance with the contract requirements for the item or items in question.

If Contractor desires an extension of time to complete the corrective work, Contractor shall make such request in writing within 10 calendar days of receipt of the notice of deficiency. After the Contractor has filed a request for an extension of time, the Village will notify the Contractor, in writing, whether or not such extension will be approved.

Should the Contractor fail to complete the corrective work within the 14 calendar days or within such extended time as may have been allowed, the Contractor shall be liable and shall pay to the Village the amount shown in the Schedule of Deductions for Each Day

2018 STREET IMPROVEMENTS VILLAGE OF VILLA PARK

of Overrun in Contract Time, not as a penalty but as liquidated damages, for each day of overrun beyond the 14 calendar days or such extended time as may have been allowed.

MAINTENANCE OF ROADWAYS

Effective: September 30, 1985

Revised: November 1, 1996

Beginning on the date that work begins on this project, the Contractor shall assume responsibility for normal maintenance of all existing roadways within the limits of the improvement. This normal maintenance shall include all repair work deemed necessary by the Engineer, but shall not include snow removal operations. Traffic control and protection for maintenance of roadways will be provided by the Contractor as required by the Engineer.

If items of work have not been provided in the contract, or otherwise specified for payment, such items, including the accompanying traffic control and protection required by the Engineer, will be paid for in accordance with Article 109.04 of the "Standard Specifications".

KEEPING ROADS OPEN TO TRAFFIC

All roads shall remain open to traffic unless otherwise shown on the contract plans. When necessary to close one lane because of construction, the Contractor shall maintain one-way traffic during construction hours with the use of signs and flaggers as shown on the Traffic Control Standards. Two lanes of traffic will be maintained during nights and weekends when no construction activities are being carried on.

Work under a separate contract may be ongoing on Second Avenue from Holly Court to Division Street during construction. Contractor shall coordinate schedules with all Contractors working in the area to minimize delays and conflicts.

RESPONSIBILITY FOR VANDALISM

The Contractor shall be responsible for the protection of all equipment and materials. Any equipment or materials which are stolen, missing, damaged or vandalized shall be the Contractor's responsibility to repair or replace as needed at no additional cost to the contract.

The Contractor shall be responsible for the defacement of any concrete pours before they have set up. Concrete pavement, sidewalk, driveway, or curbing that has been

2018 STREET IMPROVEMENTS VILLAGE OF VILLA PARK

defaced, in the opinion of the Engineer, shall be removed and replaced by the Contractor at Contractor's expense.

USE OF FIRE HYDRANTS

Revise Article 107.18, Use of Fire Hydrants, of the Standard Specifications to read:

"107.18 Use of Fire Hydrants. If Contractor requires water for the completion of construction operations, and desires to obtain water from the Village, the Contractor shall make written application to the Village. If such application is approved by the Village, the Contractor shall obtain water from the fire hydrant located at 100 West Home Avenue, adjacent to the Village of Villa Park Fleet Maintenance Garage. Contractor's use of said hydrant and methods of obtaining water shall be in compliance with all applicable ordinances, rules, and regulations concerning such use. Contractor shall furnish all labor and equipment necessary to make a connection to said hydrant, and to obtain and transport water.

Prior to obtaining water, Contractor shall make written application to the Village for temporary use of a hydrant meter. If the application for temporary use of a hydrant meter is approved, the Contractor shall provide a deposit of three-thousand dollars (\$3,000.00) to the Village for the temporary use of said hydrant meter, which deposit will be held by the Village until such time that the meter is returned to the Village by the Contractor in satisfactory condition. Contractor shall use said hydrant meter when obtaining water, and shall comply with all conditions for the use of said meter. Contractor shall return the hydrant meter to the Village within 24 hours of project completion and within 24 hours of any request by the Village that the hydrant meter be returned.

If Contractor makes application for temporary use of a hydrant meter and the application is not approved, Contractor shall make record of the quantity of water obtained, along with the date and time obtained, and shall report such information after each use to the Village of Villa Park Public Works Department, 11 West Home Avenue. If such use takes place outside of the normal working hours of the Public Works Department, Contractor shall report such information immediately upon the commencement of normal working hours.

Contractor shall not use, operate or obtain water from any hydrants other than the hydrant prescribed. Contractor shall not obtain water from the Village for construction operations or activities not under contract with the Village.

If a water main break occurs and the Village determines that the water main break is a result of Contractor's use of a hydrant, the Village may require the Contractor to repair the water main break in accordance with all applicable construction standards and

requirements and at no cost to the contract, or may repair the water main break by other means and invoice the Contractor for reimbursement of the Village's costs.

Water usage will be measured according to the Special Provisions WATER USAGE DEDUCTION and WATER USAGE CREDIT."

TRENCH BACKFILL AND PIPE BEDDING

All trench backfill and pipe bedding materials furnished under this contract shall be virgin, non-recycled materials.

All trench backfill shall be crushed aggregate of CA-6 gradation. The aggregate material shall be placed in lifts not exceeding 8 in. in depth, loose measurement, and compacted by mechanical means to the satisfaction of the Engineer.

All pipes installed under this contract shall be placed on a bedding of crushed aggregate of CA-7 or CA-11 gradation having a minimum thickness of 4 in. The bedding shall be placed to a minimum of 12 in. above the top of the pipe and any fittings.

The cost of furnishing and installing pipe bedding materials will not be paid for separately but shall be included in the cost of items to which this work pertains.

EXCAVATION AND BACKFILLING OF DRAINAGE AND UTILITY STRUCTURES

Excavation, bedding and backfilling of drainage and utility structures which are constructed, reconstructed, or adjusted as a part of this contract will not be paid for separately but shall be included in the cost of the items to which this work pertains.

SALVAGE AND DISPOSAL OF EXISTING MATERIALS

Existing manufactured materials which are removed and are not to be reused, including, but not limited to, frames, grates, lids, castings, sign posts, sign panels, fire hydrants, valves, stops, and fittings, shall remain the property of the Village unless the Engineer waives this requirement as specified herein.

Existing manufactured materials which are removed and are not to be reused will be inspected by the Engineer. Materials which are determined by the Engineer to be in satisfactory condition shall remain the property of the Village and shall be delivered by the Contractor to the Village of Villa Park Public Works Department yard located at 51 South Ardmore Avenue in Villa Park. Delivery shall be made during the normal working hours of the Village of Villa Park Public Works Department and the Contractor shall coordinate the day, time, and other details of delivery with the Village.

2018 STREET IMPROVEMENTS VILLAGE OF VILLA PARK

Materials which are determined by the Engineer to be in unsatisfactory condition shall become the property of the Contractor and shall be removed from the site by the end of the workday and properly disposed of by the Contractor.

The delivery or disposal of materials will not be paid for separately but shall be included in the cost of all items that include removal of existing materials.

FRAMES, GRATES AND LIDS

Frames, grates, lids and all other castings furnished under this contract shall be in accordance with Section 602 and Section 604 of the Standard Specifications, except as modified herein.

Castings shall conform to ASTM A48 Class 30. Castings shall be free of cracks, holes, swells, cold shuts, and patches. Castings shall not be coated or painted.

Frames, grates, lids and other castings shall be furnished in accordance with the following:

Type 1 frames and closed lids shall be Neenah R-1713 self-sealing or approved equal.

Type 1 frames and open lids shall be Neenah R-1713 or approved equal.

Type 11 frames and grates located in barrier curb and gutter shall be Neenah R-3281-A with curb box or approved equal.

Type 11 frames and grates located in depressed curb and gutter shall be Neenah R-3281-A with depressed curb grate or approved equal.

All other castings not specified above shall be as shown on the plans or as directed by the Engineer. If any of the castings specified are not compatible in the field due to frame height or other constraints, the Contractor shall propose an alternate casting to the Engineer for approval and shall furnish the alternate casting if approved.

Frames, grates, lids and other castings located within curb ramps or crosswalks shall be substituted with ADA compliant castings.

All closed lid castings furnished under this contract shall be self-sealing, gasketed, watertight, and shall have machined bearing surfaces and concealed pick holes. The top surface of all closed lids shall be embossed with the words "VILLAGE OF VILLA PARK". The top surface of closed lids shall also be embossed with the word "SANITARY", "STORM", or "WATER" as appropriate.

2018 STREET IMPROVEMENTS VILLAGE OF VILLA PARK

Enviro-curb logos on curb boxes for Type 11 frames and grates shall have the words "DUMP NO WASTE" and "DRAINS TO RIVER" or "DRAINS TO WATERWAY" cast into the top of all curb boxes.

This work will not be paid for separately but shall be included in the cost of all pay items that include the furnishing of frames, grates, lids, or other castings.

DATE OF MANUFACTURE

All manufactured materials furnished under this contract, including, but not limited to, frames, grates, lids, castings, fire hydrants, pipe, drainage and utility structures, valves, stops, and fittings, shall have been manufactured no earlier than January 1 of the calendar year in which they are to be installed.

IRON AND STEEL MATERIALS

All iron and steel materials furnished under this contract shall be domestically manufactured or produced and fabricated in accordance with Article 106.01 of the Standard Specifications. The Contractor shall provide the necessary documentation to show that all steel for the project shall be manufactured in the U.S.A. and be less than one year old.

PROTECTION OF EXISTING DRAINAGE FACILITIES DURING CONSTRUCTION

Unless otherwise noted in the contract plans, the existing drainage facilities shall remain in use during the period of construction.

Locations of existing drainage structures and sewers, if shown on the contract plans, are approximate. Prior to commencement of work, the Contractor, at his/her own expense, shall determine the exact location of existing structures which are within the proposed construction site.

All drainage structures are to be kept free from any debris resulting from construction operations. All work and materials necessary to prevent accumulation of debris in the drainage structure resulting from construction operations shall be removed at the Contractor's own expense, and no extra compensation will be allowed.

Unless reconstruction or adjustment of an existing manhole, catch basin, or inlet is called for in the contract plans or ordered by the Engineer, the proposed work shall meet the existing elevations of these structures. Should reconstruction or adjustment of a drainage structure be required by the Engineer in the field, the necessary work and

2018 STREET IMPROVEMENTS VILLAGE OF VILLA PARK

payment shall be done in accordance with Section 602 and Article 104.02 respectively, of the Standard Specifications.

Existing frames and grates are to remain unless otherwise noted in the contract plans or as directed by the Engineer. Frames and grates that are missing or damaged prior to construction shall be replaced. The type of replacements frame or grate shall be determined by the Engineer, and replacement and payment for same shall be in accordance with Section 604 and Article 104.02 respectively, of the Standard Specifications unless otherwise noted in the plans or special provisions.

EXISTING SEWER REMOVAL

This work shall consist of the removal of existing sewers that are no longer in service or are in direct conflict with the proposed improvements.

Existing sewers shall be removed only as directed by the Engineer. Excavated pipe material shall be disposed of by the Contractor in accordance with Article 202.03 of the Standard Specifications.

The ends of the existing sewers shall be plugged at both ends with a minimum of two (2) feet of non-shrink concrete/mortar plugs to the satisfaction of the Engineer.

Trenches resulting from the removal of sewers shall be backfilled in accordance with the applicable requirements of Article 550.07. Backfill of removal trenches (including Trench Backfill) shall be included in this item.

This work shall not be paid for separately, but shall be included in the cost of the contract.

PLUGGING EXISTING MANHOLES AND PIPES

This work shall consist of plugging holes in manholes where sewer pipes have been removed or abandoned as shown on the plans and as determined by the Engineer. The holes shall be plugged with brick and non-shrink concrete mortar to the satisfaction of the Engineer. The non-shrink concrete mortar shall completely fill the holes and keep all water from entering the manhole. When sewers to be removed or abandoned tie directly into a pipe, the pipe shall be plugged with non-shrink concrete mortar to the satisfaction of the engineer. The pipe shall be water-tight, and the inside of the pipe shall be free of excess material that might restrict flow.

All labor, materials, and equipment necessary to complete the work as specified herein shall not be paid for separately, but shall be included in the cost of the contract.

IEPA CLEAN CONSTRUCTION AND DEMOLITION DEBRIS (CCDD)

All removal or excavation items being disposed of at an uncontaminated soil fill operation or Clean Construction and Demolition Debris (CCDD) fill site shall meet the requirements of Public Act 96-1416. All costs associated with meeting these requirements shall be included in the unit price cost for the associated removal or excavation items in the contract. These costs shall include but are not limited to all required testing, lab analysis, certification by a licensed professional engineer, and State and local tipping fees.

A copy of signed Illinois Environmental Protection Agency Form LPC 663 and associated reports can be accessed on the Village of Villa Park Public Works Website (www.invillapark.com/196/Public-Works-Department).

The CONTRACTOR is required to submit copies of all dump debris tickets to the ENGINEER.

PAVEMENT CORES AND WASTE DISPOSAL REPORTS

Pavement cores and waste disposal characterization was performed at the various project locations by Testing Service Corporation. Summary reports of the pavement core and waste disposal characterization results can be accessed on the Village of Villa Park Public Works Website (www.invillapark.com/196/Public-Works-Department). The summary reports are for informational purposes only. Actual site conditions may vary.

MATERIAL AND EQUIPMENT STORAGE

The project site may have limited access and boundary constraints, all of which the Contractor accepts full responsibility. Any staging area(s) for materials, equipment, or other which are required by the Contractor shall be the responsibility of the Contractor.

If necessary, the Contractor shall enter into a separate contract with a private property owner which is outside the scope of this contract.

CONSTRUCTION NOTICES

It shall be the CONTRACTOR's responsibility to distribute all construction notifications. This work will not be measured for payment but shall be included in the total contract cost. The construction notices shall be reviewed and approved by the ENGINEER prior to being distributed. Notices shall be issued at the following stages:

**2018 STREET IMPROVEMENTS
VILLAGE OF VILLA PARK**

	<u>Activity</u>	<u>Notice Period Required</u>
1.	Prior to curb and driveway removal.	3 consecutive days prior
2.	Prior to water and sanitary service Interruption.	2 consecutive days prior
3.	Prior to pavement removal.	2 consecutive days prior
4.	Prior to paving.	2 consecutive days prior

The CONTRACTOR will also be responsible for distributing and/or redistributing notices in case of any delays due to inclement weather or for any other reason for extended stoppages (i.e. strikes) in the construction schedule.

Notices shall be considered distributed when all affected residents have received notices as well as a copy delivered and/or emailed to Public Works. The copy to Public Works shall be delivered the same day it is distributed to the residents.

Should the CONTRACTOR fail to distribute or post notices per the request of the VILLAGE, the CONTRACTOR shall not be allowed to start work on the given task until proper notification has been provided. No additional contract time will be allowed for compliance with this requirement.

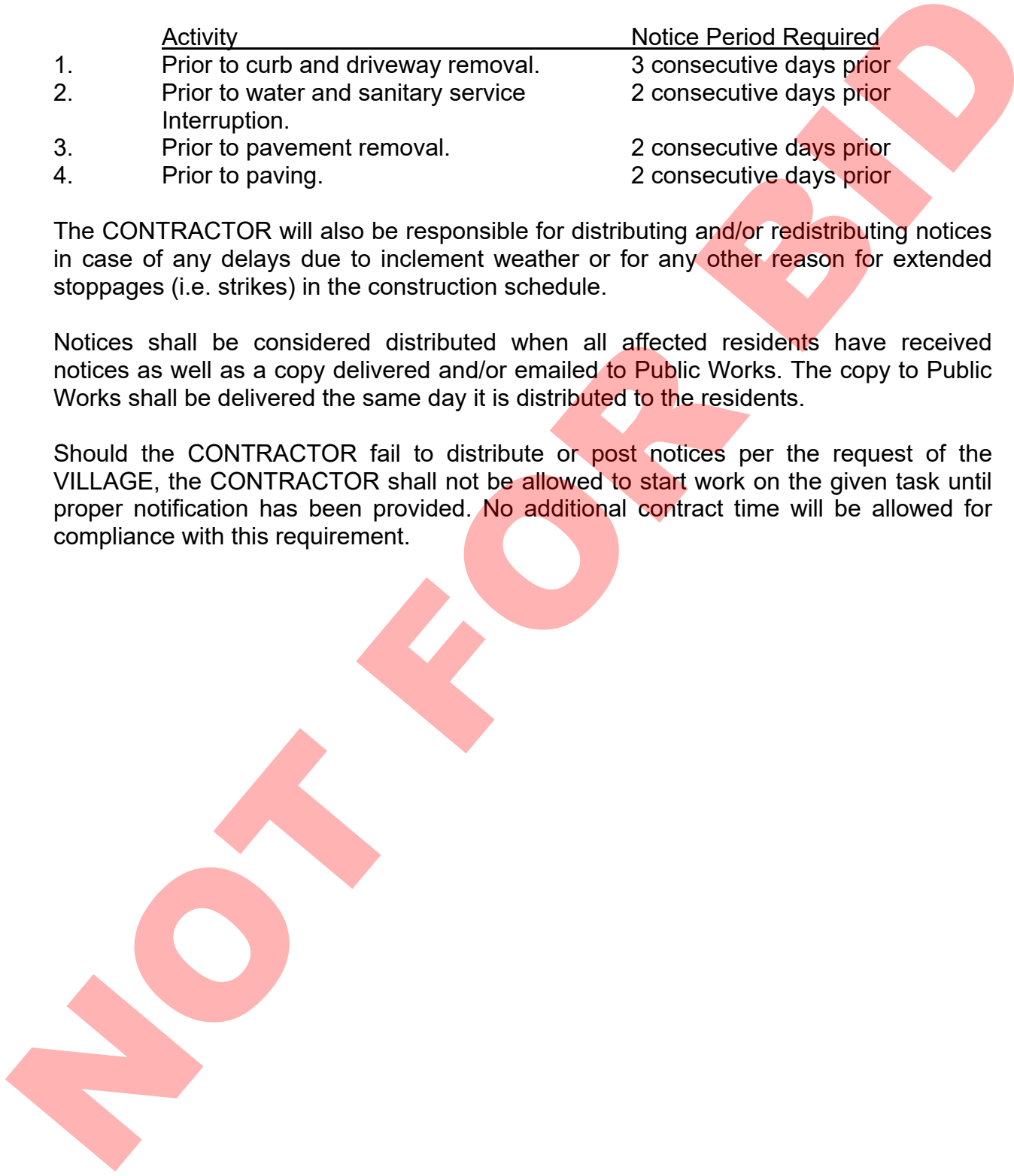

PAY ITEM SPECIAL PROVISIONS

PAY ITEM #3 – TREE TRUNK PROTECTION

Description. All work shall be in accordance with the applicable portions of Section 201 of the Standard Specifications.

At locations directed by the ENGINEER, the CONTRACTOR shall provide two (2") inch by six (6") inch by eight (8') foot boards banded continuously around each trunk to adequately prevent scarring of trees as marked on the plans or designated by the ENGINEER.

For multi-stem trees, or trees under six (6") inches in diameter, temporary fencing (snow fence) at the drip line will serve as trunk protection.

Method of Measurement and Basis of Payment. This work will be measured and paid for at the contract unit price per each for TREE TRUNK PROTECTION.

PAY ITEM #4 – TREE ROOT PRUNING

Description. This work shall consist of performing tree root pruning. This work shall be in accordance with Section 201 of the Standard Specifications, except as modified herein.

Fertilizer nutrients and supplemental watering will not be paid for separately, but shall be included in the cost of TREE ROOT PRUNING.

Method of Measurement. This work will be measured for payment as each per tree.

Basis of Payment. This work will be paid for at the contract unit price per each for TREE ROOT PRUNING.

PAY ITEM #5 – TREE PRUNING

Description. This work shall consist of performing tree pruning. This work shall be in accordance with Section 201 of the Standard Specifications and the current ANSI A300 (Part 1) – Pruning standard, except as modified herein.

All tree pruning shall be performed by a professional arborist.

Method of Measurement. This work will be measured for payment as each per tree.

Basis of Payment. This work will be paid for at the contract unit price per each for TREE PRUNING.

PAY ITEM #8 – TRENCH BACKFILL

Description. The provisions of Section 208 of the "Standard Specifications for Road and Bridge Construction" shall be modified such that the material used for trench backfill shall be crushed limestone. The trench backfill shall be compacted only by Method 1, as defined in Article 550.07 of the Standard Specifications, which states the material shall be deposited in uniform layers not exceeding 150 mm (6 in) thick (loose measure), and each layer shall be compacted by ramming or tamping with tools approved by the ENGINEER. Jetting of the trench will not be an acceptable method of compaction. Material used as trench backfill shall be virgin, non-recycled materials.

Method of Measurement and Basis of Payment. This work shall be measured in place and paid for at the contract unit price per cubic yard for TRENCH BACKFILL.

PAY ITEM #9 – GEOTECHNICAL FABRIC FOR GROUND STABILIZATION

Description. This work shall consist of furnishing and installing geotechnical fabric over subgrades for ground stabilization in accordance with Sections 210 and 1080 of the Standard Specifications, as modified herein.

The fabric for ground stabilization shall be a woven fabric material and shall have a minimum weight of 4.0 ounces per square yard. All other physical properties shall be in accordance with Section 1080 of the Standard Specifications.

Method of Measurement and Basis of Payment. This work shall be measured in place and paid for at the contract unit price per square yard for GEOTECHNICAL FABRIC FOR GROUND STABILIZATION.

PAY ITEM #10 – SODDING

Description. This work shall consist of preparing the ground surface, furnishing and applying topsoil to a maximum 4" depth, fertilizing the areas to be sodded, and furnishing and placing sod as specified in the plans. All work shall be in accordance with Sections 202, 211, and 252 of the Standard Specifications, and as specified herein.

CONTRACTOR shall locate all buffalo boxes and sanitary cleanouts prior to excavating for topsoil. CONTRACTOR shall place a 4' lath behind each box and cleanout to identify its location. A list of all b-boxes which cannot be found shall be provided to the ENGINEER.

Any excavation required to trim landscaped areas to the newly required grade shall be included in the cost of this item.

Excess spoil removed from parkways shall be immediately removed from the site and shall at no time be stored on the roadway. All sod shall be placed before the final roadway surface is installed.

The topsoil shall be free of large roots, brush, sticks, weeds, stones larger than ½" in diameter and any other litter. The topsoil shall be spread to a smooth compacted uniform thickness of not less than 4".

Fertilizer nutrients shall be applied in accordance with Section 252.03 of the Standard Specifications and shall be included in the cost for SODDING.

Method of Measurement and Basis of Payment. This work shall be measured in place and paid for at the contract unit price per square yard for SODDING.

PAY ITEM #12 – INLET FILTERS

Description. This work shall consist of installing, maintaining and cleaning inlet filters as shown on the plans or as directed by the Engineer. This work shall be in accordance with Section 280 of the Standard Specifications, except as modified herein.

Contractor shall inspect and clean all inlet filters weekly, after every rainfall, and additionally as needed. Maintenance and cleaning of inlet filters will not be paid for separately but shall be included in the cost of this work.

Method of Measurement and Basis of Payment. This work shall be measured and paid for at the contract unit price per each for INLET FILTERS.

PAY ITEM #14 – BITUMINOUS MATERIALS (TACK COAT)

Description. This work shall consist of the preparation and application of bituminous tack coat on concrete or HMA bases prior to HMA placement. This work shall be in accordance with Section 406 of the Standard Specifications, except as modified herein.

Bituminous tack coat shall be placed at least one hour in advance of the placement of HMA, but no more than 48 hours in advance of the placement of HMA. If Contractor places tack coat more than 48 hours in advance of the placement of HMA, the tack coat will not be measured for payment, and Contractor will place tack coat again in accordance with this provision. Tack coat shall not be placed on weekends or on holidays unless permitted by the Engineer. Tack coat shall not be placed before

weekends or holidays when placement of HMA is not expected to take place until after the weekend or holiday, unless permitted by the Engineer.

Basis of Payment. This work will be paid for at the contract unit price per pound for BITUMINOUS MATERIALS (TACK COAT).

PAY ITEM #17 & 18 – PORTLAND CEMENT CONCRETE DRIVEWAY PAVEMENT

Description. This work shall consist of placing Portland Cement Concrete driveway pavement on a compacted aggregate base course in accordance with Sections 351 and 423 of the Standard Specifications, and as specified herein.

Residential driveway installation shall include Portland Cement Concrete installed to a minimum thickness of 6-inches and the placement and compaction of 4-inches of Aggregate Base Course, Type B on a compacted subgrade. Commercial driveway installation shall include Portland Cement Concrete installed to a minimum thickness of 8-inches and the placement and compaction of 6-inches of Aggregate Base Course, Type B on a compacted subgrade. The installation of all Aggregate Base Course shall be included in the cost of this item.

If filling is required in the driveway subgrade, it shall consist of placing and compacting an approved granular material to the satisfactions of the ENGINEER. Any required filling shall be included in the cost of this item.

All framing shall be set to final grade of the pour. No angle irons will be allowed. No watering cans shall be allowed on site.

The finish of the driveway shall match the driveway behind of the sidewalk. Where the finish behind the sidewalk is “california” or “letter box”, the contractor shall match this finish on the new apron. It shall be the contractor’s responsibility to verify the finish at each location. Installation of this finish shall be considered included in the cost of this item.

Method of Measurement and Basis of Payment. This work shall be measured in place and paid for at the contract unit price per square yard for PORTLAND CEMENT CONCRETE DRIVEWAY PAVEMENT, thickness specified.

PAY ITEM #19 & 20 – PORTLAND CEMENT CONCRETE SIDEWALK

Description. This work shall consist of placing either 5-inches or 8-inches of Portland Cement Concrete sidewalk on a compacted subbase in accordance with Sections 311 and 424 of the Standard Specifications, and as specified herein.

2018 STREET IMPROVEMENTS VILLAGE OF VILLA PARK

Except for locations adjacent to commercial driveways, sidewalk installation shall include Portland Cement Concrete installed to a minimum thickness of 5-inches and the placement and compaction of 4-inches of Subbase Granular Material, Type B on a compacted subgrade. Sidewalk thickness shall be increased to 6-inches when placed adjacent to residential driveways. Increasing sidewalk thickness at residential driveways shall not be paid for separately, but included in the cost of this item.

At locations adjacent to commercial driveways as shown on the plans or directed by the ENGINEER, sidewalk installation shall include Portland Cement Concrete installed to a minimum thickness of 8-inches and the placement and compaction of 6-inches of Subbase Granular Material, Type B on a compacted subgrade.

The installation of Subbase Granular Material, Type B shall be included in the cost of the sidewalk.

If filling is required in the sidewalk subgrade, it shall consist of placing and compacting an approved granular material to the satisfaction of the ENGINEER. Any required filling shall be included in the cost of the sidewalk.

All framing shall be set to final grade of the pour. No angle irons will be allowed. No watering cans shall be allowed on site.

Method of Measurement. Portland Cement Concrete Sidewalk shall be measured for payment in place, and the area computed in square feet.

Basis of Payment. This work will be paid for at the contract unit price per square feet for PORTLAND CEMENT CONCRETE SIDEWALK, of the thickness specified.

PAY ITEM #21 – DETECTABLE WARNINGS

Description. This work shall consist of installing detectable warnings. This work shall be in accordance with Section 424 of the Standard Specifications, except as modified herein.

Detectable warnings shall be installed at curb ramps and other locations where pedestrians are required to cross a hazardous vehicular way. Detectable warnings shall also be installed at alleys and commercial entrances where permanent traffic control devices are present.

Materials. Detectable warnings shall be pre-cast tiles. Installation shall be cast-in-place. Surface mounted applications will not be permitted. Detectable warnings shall be red in color. Detectable warning tiles shall be either rectangular or radial in shape as shown on the plans or as directed by the Engineer. The product or products to be used for detectable warnings shall be approved by the Engineer prior to use.

**2018 STREET IMPROVEMENTS
VILLAGE OF VILLA PARK**

Construction. Installation shall be according to the manufacturer's specifications and as directed by the Engineer.

Where a curb ramp is 5 ft. in width or less and a rectangular detectable warning tile is to be used, the installation shall consist of a single detectable warning tile. If a pre-cast detectable warning tile is not manufactured in the width of the curb ramp, a larger detectable warning tile shall be furnished and shall be cut to the width of the curb ramp.

Installation of multiple detectable warning tiles at a single curb ramp will only be permitted where a curb ramp exceeds 5 ft. in width or where radial detectable warning tiles are to be used. Where multiple detectable warning tiles are permitted at a single curb ramp, they shall be mechanically joined prior to installation.

Method of Measurement. Detectable warnings will be measured for payment in place and the area computed in square feet.

Basis of Payment. This work will be paid for at the contract unit price per square foot for DETECTABLE WARNINGS.

PAY ITEM #22 – PAVEMENT REMOVAL

Description. This work shall consist of the removal and disposal of existing pavement, including all necessary excavation, as shown on the plans or as directed by the Engineer. This work shall be completed in accordance with Sections 202 and 440 of the Standard Specifications, except as modified herein.

Pavement removal shall include the removal of the entire existing pavement section and excavation (including stone, earth, clay, etc.) required to get down to the proper elevation for aggregate base course installation.

Method of Measurement and Basis of Payment. This work shall be measured and paid for at the contract unit price per square yard for PAVEMENT REMOVAL.

PAY ITEM #24 – DRIVEWAY PAVEMENT REMOVAL

Description. This work shall consist of the removal and disposal of existing driveway pavement, including all necessary excavation, as shown on the plans or as directed by the Engineer. This work shall be completed in accordance with Sections 202 and 440 of the Standard Specifications, except as modified herein.

Driveway pavement removal shall include the removal of existing driveway pavement and base course to meet the proposed lines and grades shown on the plans and as

directed by the Engineer. All excavation and base course removal required shall be included in this item.

Method of Measurement and Basis of Payment. This work shall be measured and paid for at the contract unit price per square yard for DRIVEWAY PAVEMENT REMOVAL.

PAY ITEM #25 – CURB REMOVAL

Description. This work shall consist of the removal and disposal of existing curb, including all necessary excavation, as shown on the plans or as directed by the Engineer. This work shall be in accordance with Sections 202 and 440 of the Standard Specifications, except as modified herein.

Excavation will not be paid for separately but shall be included in the cost of this item. The Contractor shall excavate all material necessary to build the proposed curb subbase in accordance with Section 202 of the Standard Specifications. Excavated material will not be permitted to be stockpiled behind the curb.

Method of Measurement and Basis of Payment. This work shall be measured and paid for at the contract unit price per lineal foot of CURB REMOVAL.

PAY ITEM #26 – COMBINATION CURB AND GUTTER REMOVAL

Description. This work shall consist of the removal and disposal of existing curb and gutter, including all necessary excavation and pavement removal, as shown on the plans or as directed by the Engineer. This work shall be in accordance with Sections 202 and 440 of the Standard Specifications, except as modified herein.

Excavation will not be paid for separately but shall be included in the cost of this item. The Contractor shall excavate all material necessary to build the proposed curb and gutter subbase in accordance with Section 202 of the Standard Specifications. Excavated material will not be permitted to be stockpiled behind the curb.

Existing pavement adjacent to the curb and gutter removal operations shall be removed as necessary to facilitate construction of the proposed curb and gutter. Pavement removal required by curb and gutter removal operations shall be include in the cost of this item.

Method of Measurement and Basis of Payment. This work shall be measured and paid for at the contract unit price per lineal foot of COMBINATION CURB AND GUTTER REMOVAL.

PAY ITEM #27 – SIDEWALK REMOVAL

Description. This work shall consist of the removal and disposal of existing sidewalk at locations shown on the plans or as directed by the Engineer. This work shall be completed in accordance with Sections 202 and 440 of the Standard Specifications, except as modified herein.

Excavation will not be paid for separately but shall be included in the cost of this item. The Contractor shall excavate all material necessary to meet the lines and grades shown on the plans and as directed by the Engineer. Additional excavation required to comply with ADA requirements shall be included in the cost of this item.

Method of Measurement and Basis of Payment. This work shall be measured and paid for at the contract unit price per square foot for SIDEWALK REMOVAL.

PAY ITEM #28 – AGGREGATE SHOULDER, TYPE A

Description. This work shall consist of furnishing and placing new aggregate shoulder material at locations shown the plans or as directed by the Engineer. This work shall be completed in accordance with Section 481 of the Standard Specifications, and as specified herein.

A minimum two-inch lift of aggregate shall be furnished and placed over the existing aggregate shoulder located at the Sugar Creek Golf Course Parking Lot. The CONTRACTOR shall fill any holes, depressions or loose spots with additional material, prior to placing the two-inch lift. The aggregate shoulders shall be compacted in accordance with Section 481.

Any clearing of ground vegetation required to place the aggregate should shall be included in the cost of this item.

Method of Measurement and Basis of Payment. This work shall be measured and paid for at the contract unit price per square yard for AGGREGATE SHOULDER, TYPE A.

PAY ITEM #29 – DOMESTIC WATER SERVICE BOXES TO BE ADJUSTED

Description. This work shall consist of adjusting domestic water service boxes to match the proposed finished grade as directed by the ENGINEER, in accordance with Section 565 of the STANDARD SPECIFICATIONS.

**2018 STREET IMPROVEMENTS
VILLAGE OF VILLA PARK**

Top sections, extensions and/or caps compatible with the existing box, may be required to adjust the box to the final grade. Replacement of damaged caps shall be considered included in this item.

For boxes which are located in sidewalks or driveways constructed as part of this improvement, the CONTRACTOR is responsible for confirming all caps and bolts can be opened after the concrete or asphalt has been placed. The CONTRACTOR shall confirm each roundway is keyable. If the CONTRACTOR cannot key the roundway, he shall notify the ENGINEER. After the work has been completed, the CONTRACTOR shall open each box in the presence of the ENGINEER.

Method of Measurement and Basis of Payment. This work shall be measured and paid for at the contract unit price per each for DOMESTIC WATER SERVICE BOXES TO BE ADJUSTED.

PAY ITEM #30 – CATCH BASINS, TYPE C

Description. This work shall consist of constructing Catch Basins, Type C at locations shown on the plans in accordance with the detail on the plan and Section 602 of the Standard Specifications, except as modified herein.

The CONTRACTOR is responsible for tying in all existing storm sewers to the proposed structure. Up to 5 feet of new sewer (if required) for each existing sewer tying into the proposed structure shall be considered included in the cost of this item. Connections to existing storm sewers should be made using non-shear mission couplings. The Contractor shall be responsible for verifying the size, inverts and locations of the existing sewers to be connected to the proposed structure. Any existing storm sewers that are damaged during construction shall be replaced in kind by the CONTRACTOR at no cost to the VILLAGE. The pipe, couplings, and trench backfill shall be included in the cost of the structure and will not be paid for separately.

When a proposed catch basin is to be installed at the location of an existing drainage structure, the removal of the existing structure shall be included in this item.

Removing existing drainage structures shall consist of the removal and disposal of existing catch basins and inlets in accordance with Section 605 of the Standard Specifications. The word STRUCTURE shall be understood to mean catch basins and inlets as the case may be.

Method of Measurement and Basis of Payment. This work shall be measured and paid for per each for CATCH BASINS, TYPE C, frame and grate specified.

PAY ITEM #31 – INLETS, TYPE A

Description. This work shall consist of constructing Inlets, Type A at locations shown on the plans in accordance with the detail on the plan and Section 602 of the Standard Specifications, except as modified herein.

The CONTRACTOR is responsible for tying in all existing storm sewers to the proposed structure. Up to 5 feet of new sewer (if required) for each existing sewer tying into the proposed structure shall be considered included in the cost of this item. Connections to existing storm sewers should be made using non-shear mission couplings. The Contractor shall be responsible for verifying the size, inverts and locations of the existing sewers to be connected to the proposed structure. Any existing storm sewers that are damaged during construction shall be replaced in kind by the CONTRACTOR at no cost to the VILLAGE. The pipe, couplings, and trench backfill shall be included in the cost of the structure and will not be paid for separately.

When a proposed inlet is to be installed at the location of an existing drainage structure, the removal of the existing structure shall be included in this item.

Removing existing drainage structures shall consist of the removal and disposal of existing catch basins and inlets in accordance with Section 605 of the Standard Specifications. The word STRUCTURE shall be understood to mean catch basins and inlets as the case may be.

Method of Measurement and Basis of Payment. This work shall be measured and paid for per each for INLETS, TYPE A, frame and grate specified.

PAY ITEM #36 – CONCRETE CURB, TYPE B

Description. This work shall consist of the construction of concrete curb, type b, including all necessary embankment as shown on the plans or as directed by the Engineer. This work shall be in accordance with the detail in the plans and Sections 606, 205, and 311 of the Standard Specifications, except as modified herein.

Backfill behind the proposed back of curb shall be in accordance with Section 205 of the Standard Specifications.

Concrete curb shall be constructed on a prepared base of mechanically compacted crushed aggregate of CA-6 gradation having a minimum compacted thickness of 4 in.

Wood forms shall be used. Forms constructed of steel or Masonite will not be permitted. Forms for radius sections of the combination concrete curb and gutter shall be constructed of 1 in. thick wood boards.

2018 STREET IMPROVEMENTS VILLAGE OF VILLA PARK

The height of the curb head may vary as shown on the plans or as directed by the Engineer. Variations in the height of the curb head will not be paid for separately but shall be included in the cost of this item. The CONTRACTOR is responsible for matching the existing dimensions of the adjacent concrete curb when applicable.

Expansion joints shall be constructed at 60 ft. maximum centers. Expansion joints shall also be constructed at all construction joints, all points of curvature, all points of tangency, within 5' on either side of all curb structure castings, and at additional locations as directed by the Engineer. Expansion joints shall consist of a 1 in. thick preformed bituminous expansion joint filler that extends the full cross section of the combination concrete curb and gutter. Expansion joint filler material that is larger than the cross section of the combination concrete curb and gutter shall be cut to the exact cross section of the combination concrete curb and gutter. Expansion joints shall have two 18 in. long, No. 6 non-deformed epoxy-coated steel dowel bars placed at mid-depth. The dowel bars shall have a greased plastic expansion cap placed on one end of each dowel bar a minimum of 1 in. from the end of the dowel bar.

Where proposed concrete curb is to be constructed abutting existing concrete curb, the dowel bars shall be drilled into the existing concrete curb. This work will not be paid for separately but shall be included in the cost of this item.

Contraction joints shall be constructed at 15 ft. maximum centers. Where the location of a contraction joint coincides with the location of an expansion joint, the contraction joint may be omitted at the discretion of the Engineer. Contraction joints shall be tooled and sawed. Sawing of contraction joints shall commence as soon as the concrete has hardened sufficiently to permit sawing without excessive raveling, but in no case shall sawing commence less than 4 hours or more than 24 hours after the concrete is placed. Sawing of contraction joints shall be to a depth equal to 1/3 the thickness of the gutter flag and to a width of not less than 1/8 in. Contraction joints shall be sealed according to Article 420.12, except that joints shall be sealed with polysulfide or polyurethane joint sealant.

If Contractor fails to construct joints in accordance with the requirements of this provision and the curb cracks, the Contractor shall remove and replace the affected section of concrete curb extending the full length between the two adjacent joints on either side of the crack. This work will not be paid for but shall be at the Contractor's expense.

Upon removal of the forms from the back of the concrete curb, excavated areas behind the concrete curb shall be immediately backfilled. Areas where pavement or sidewalks are to be constructed shall be backfilled with crushed aggregate of CA-6 or CA-7 gradation and mechanically compacted. Areas where topsoil and sodding are to be placed shall be backfilled with non-organic material acceptable to the Engineer. This work will not be paid for separately but will be included in the cost of this item.

Basis of Payment. This work will be paid for at the contract unit price per foot for CONCRETE CURB, TYPE B.

PAY ITEM #37 & 38 – COMBINATION CONCRETE CURB AND GUTTER

Description. This work shall consist of the construction of combination concrete curb and gutter, type specified, including all necessary embankment as shown on the plans or as directed by the Engineer. This work shall be in accordance with the detail in the plans and Sections 606, 205, and 311 of the Standard Specifications, except as modified herein.

Backfill behind the proposed back of curb shall be in accordance with Section 205 of the Standard Specifications.

Combination concrete curb and gutter shall be constructed on a prepared base of mechanically compacted crushed aggregate of CA-6 gradation having a minimum compacted thickness of 4 in.

Wood forms shall be used. Forms constructed of steel or Masonite will not be permitted. Forms for radius sections of the combination concrete curb and gutter shall be constructed of 1 in. thick wood boards.

The height of the curb head may vary as shown on the plans or as directed by the Engineer. Variations in the height of the curb head will not be paid for separately but shall be included in the cost of this item.

Where combination concrete curb and gutter is constructed across driveways, alleys, sidewalk curb ramps, or other designated areas, the top of the curb shall be depressed according to the details shown on the plans or as directed by the Engineer. The transition from full height curb to depressed curb shall be made over a distance equal to at least four times the difference in height between the full height curb and the depressed curb.

Where combination concrete curb and gutter is constructed across sidewalk curb ramps, the depressed curb shall be in compliance with all applicable requirements of the Americans with Disabilities Act (ADA) and the Proposed Guidelines for Accessible Rights-of-Way (PROWAG).

Expansion joints shall be constructed at 60 ft. maximum centers. Expansion joints shall also be constructed at all construction joints, all points of curvature, all points of tangency, within 5' on either side of all curb structure castings, and at additional locations as directed by the Engineer. Expansion joints shall consist of a 1 in. thick preformed bituminous expansion joint filler that extends the full cross section of the combination concrete curb and gutter. Expansion joint filler material that is larger than

2018 STREET IMPROVEMENTS VILLAGE OF VILLA PARK

the cross section of the combination concrete curb and gutter shall be cut to the exact cross section of the combination concrete curb and gutter. Expansion joints shall have two 18 in. long, No. 6 non-deformed epoxy-coated steel dowel bars placed at mid-depth. The dowel bars shall have a greased plastic expansion cap placed on one end of each dowel bar a minimum of 1 in. from the end of the dowel bar.

Where proposed combination concrete curb and gutter is to be constructed abutting existing combination concrete curb and gutter, the dowel bars shall be drilled into the existing combination concrete curb and gutter. This work will not be paid for separately but shall be included in the cost of this item.

Contraction joints shall be constructed at 15 ft. maximum centers. Where the location of a contraction joint coincides with the location of an expansion joint, the contraction joint may be omitted at the discretion of the Engineer. Contraction joints shall be tooled and sawed. Sawing of contraction joints shall commence as soon as the concrete has hardened sufficiently to permit sawing without excessive raveling, but in no case shall sawing commence less than 4 hours or more than 24 hours after the concrete is placed. Sawing of contraction joints shall be to a depth equal to 1/3 the thickness of the gutter flag and to a width of not less than 1/8 in. Contraction joints shall be sealed according to Article 420.12, except that joints shall be sealed with polysulfide or polyurethane joint sealant.

If Contractor fails to construct joints in accordance with the requirements of this provision and the curb cracks, the Contractor shall remove and replace the affected section of combination concrete curb and gutter extending the full length between the two adjacent joints on either side of the crack. This work will not be paid for but shall be at the Contractor's expense.

Upon removal of the forms from the back of the combination concrete curb and gutter, excavated areas behind the combination concrete curb and gutter shall be immediately backfilled. Areas where pavement or sidewalks are to be constructed shall be backfilled with crushed aggregate of CA-6 or CA-7 gradation and mechanically compacted. Areas where topsoil and sodding are to be placed shall be backfilled with non-organic material acceptable to the Engineer. This work will not be paid for separately but will be included in the cost of this item.

At locations where combination concrete curb and gutter is constructed adjacent to pavement that will not be reconstructed, the area between the edge of the existing pavement and the face of the new gutter shall be cleaned of all loose material and filled with Class SI concrete to a minimum 6-inch width. The concrete shall extend from the pavement subgrade to 2-inches below the existing pavement surface. The edge of the existing pavement shall be saw cut prior to placing the concrete. This work shall not be paid for separately, but shall be included in the cost of the combination curb and gutter. The adjacent pavement surface shall then be removed to a depth of 2" and replaced with hot-mix asphalt surface course. The hot-mix asphalt surface removal and surface

course shall be paid for separately. The maximum width of the hot-mix asphalt surface removal and replacement shall be 4 feet from the face of gutter.

Basis of Payment. This work will be paid for at the contract unit price per foot for COMBINATION CONCRETE CURB AND GUTTER, type specified.

PAY ITEM #45 – EXPLORATION TRENCH, SPECIAL

Description. This work shall consist of constructing a trench for the purpose of locating an existing utility or utilities. This work shall be in accordance with Section 213 of the Standard Specifications, except as modified herein.

The exploration trench may be used to locate existing utilities regardless of whether the utilities are public or private; known or unknown; or marked or unmarked. The exploration trench may also be used to determine the material type of existing utilities and to verify clearances between multiple utilities.

The exploration trench shall be constructed at the locations shown on the plans or as directed by the Engineer. The depth of the exploration trench shall vary as necessary, but shall be sufficient to locate the utility or utilities under investigation. The width of the trench shall be sufficient to allow proper investigation of the entire trench.

Method of Measurement. The exploration trench will be measured for payment in feet of actual trench constructed.

Basis of Payment. This work will be paid for at the contract unit price per foot for EXPLORATION TRENCH, SPECIAL, regardless of the depth of the actual trench constructed.

PAY ITEM #46, 47 & 48 – TEMPORARY ACCESS

Description. This work shall consist of the construction and maintenance of an aggregate base course for maintaining access to intersecting streets and driveways as specified in Article 107.09 of the STANDARD SPECIFICATIONS. The CONTRACTOR shall provide access for all emergency vehicles and school buses, and to all abutting properties at all times during construction.

Construction Requirements: The CONTRACTOR shall maintain ingress and egress to all abutting properties during construction operations when construction operations are not taking place directly in front of the property, except for a maximum period of 4 calendar days after new concrete curb or driveway pavement is poured. Residents shall be notified a minimum of 48 hours prior to this period. Temporary driveways and entrances shall be constructed of aggregate in accordance with the applicable portions

**2018 STREET IMPROVEMENTS
VILLAGE OF VILLA PARK**

of Section 351 of the STANDARD SPECIFICATIONS and to the dimensions determined by the ENGINEER. The coarse aggregate shall be crushed stone or crushed gravel, gradation CA-6. All adjacent properties shall have access at the end of each working day.

Maintenance shall consist of placing and compacting additional aggregate of the same type and gradation as the base aggregate.

After these driveway aprons have served their purpose, the suitable aggregate shall be removed, and, at the direction and approval of the ENGINEER, utilized for other purposes, such as aggregate base course for driveways, and embankment construction or other driveway aprons or otherwise disposed of as specified in Article 202.03 of the Standard Specifications.

Method of Measurement and Basis of Payment: This work will be paid for at the contract unit price per each for TEMPORARY ACCESS (PRIVATE ENTRANCE), TEMPORARY ACCESS (COMMERCIAL ENTRANCE), or TEMPORARY ACCESS (ROAD). TEMPORARY ACCESS will only be measured and paid for once during construction. If work requires the temporary removal of aggregate for temporary access, it shall be stockpiled and replaced at the end of each working day at no additional cost to the Village.

PAY ITEM #49 – TRAFFIC CONTROL AND PROTECTION (SPECIAL)

Traffic control shall be in accordance with the applicable sections of the Standard Specifications, the “Illinois Manual on Uniform Traffic Control Devices for Streets and Highways”, any special details and Highway Standards contained in the plans, and the Special Provisions contained herein.

Special attention is called to Article 107.09 of the Standard Specification and the following Highway Standards, Details, Quality Standard for Work Zone Traffic Control Devices, Recurring Special Provisions and Special Provisions contained herein, relating to traffic control.

The Contractor shall contact the VILLAGE at least 72 hours in advance of beginning work.

STANDARDS: 701301-04, 701501-06, 701801-06, 701901-07

DETAILS: Traffic Control and Protection for Sideroads, Intersections, and Driveways (TC-10), District One Typical Pavement Marking (TC-13)

SPECIAL PROVISIONS: Maintenance for Roadways, Work Zone Traffic Control, and Flaggers in Work Zones.

Basis of Payment. This work shall be paid for at the contract unit price per lump sum for TRAFFIC CONTROL AND PROTECTION (SPECIAL).

PAY ITEM #51 – DRAINAGE & UTILITY STRUCTURES TO BE ADJUSTED

Description. This work shall consist of adjusting catch basins, manholes, valve vaults, water valves and inlets with their existing frame, in accordance with Section 602 of the Standard Specifications and as specified herein. The word STRUCTURE shall be understood to mean catch basin, manhole, valve vault, water valve or inlet as the case may be.

At locations shown on the plans or as directed by the Engineer, structures shall be adjusted with new frame and grates. New frame and grates will be paid for separately.

Each structure adjustment shall be limited to two adjustment rings. The final ring and rings under 2" on all drainage adjustments shall be rubber. The CONTRACTOR shall place a continuous strip 3/8" thick of polyurethane sealer/adhesive between the PCC structure or PCC ring and the bottom of the rubber ring. The CONTRACTOR shall also place a continuous strip 3/8" thick of polyurethane sealer/adhesive between the top of the rubber ring and the bottom of the frame.

Hydraulic cement shall be used in the adjustment of said structure to seal the outside of the adjustment rings and under the frame.

Basis of Payment. This work will be measured and paid for at the contract unit price per each for DRAINAGE & UTILITY STRUCTURES TO BE ADJUSTED.

PAY ITEM #52 – DRAINAGE & UTILITY STRUCTURES TO BE RECONSTRUCTED

Description. This work shall consist of reconstructing catch basins, manholes, valve vaults, water valves, and inlets with their existing frame and grate in accordance with Section 602 of the Standard Specifications and as specified herein. The word STRUCTURE shall be understood to mean catch basin, manhole, valve vault, water valve or inlet as the case may be.

At locations shown on the plans or as directed by the Engineer, structures shall be adjusted with new frame and grates. New frame and grates will be paid for separately.

This item includes the cost of a new precast cone section or flat slab top.

Each structure being reconstructed shall be limited to two adjustment rings. The final ring and rings less than 2" on all drainage adjustments/reconstructions shall be rubber. The CONTRACTOR shall place a continuous strip 3/8" thick of polyurethane

**2018 STREET IMPROVEMENTS
VILLAGE OF VILLA PARK**

sealer/adhesive between the PCC structure or PCC ring and the bottom of the rubber ring. The CONTRACTOR shall also place a continuous strip 3/8" thick of polyurethane sealer/adhesive between the top of the rubber ring and the bottom of the frame.

Hydraulic cement shall be used in the adjustment of said structure to seal the outside of the adjustment rings and under the frame.

Basis of Payment. This work will be paid for at the contract unit price per each for DRAINAGE & UTILITY STRUCTURES TO BE RECONSTRUCTED.

PAY ITEM #53 & 54 – HOT-MIX ASPHALT DRIVEWAY PAVEMENT

Description. Work under this item consists of construction of new HMA driveway pavement at locations shown on the plans, or as directed by the ENGINEER, in accordance with Sections 301, 351, 406 and 423 of the Standard Specifications and as directed by the ENGINEER.

CONTRACTOR shall place embankment or excavate in accordance with Sections 202 and 205 of the Standard Specifications in order to achieve the required finished grades.

Residential driveway pavement shall consist of 1 lift of 2 ½" HMA Binder Course, IL-19.0, N50, and 1 lift of 1 ½" HMA Surface Course, Mix D, N50 for a total of 4" of HMA and 6" of mechanically compacted Aggregate Base Course, Type B.

Commercial driveway pavement shall consist of 1 lift of 4" HMA Binder Course, IL-19.0, N50, and 1 lift of 2" HMA Surface Course, Mix D, N50 for a total of 6" of HMA and 8" of mechanically compacted Aggregate Base Course, Type B.

All excavation, embankment, HMA Surface Course, HMA Binder Course, and aggregate base course will not be paid for separately but shall be included in this pay item.

Basis of Payment. This work shall be measured in place and paid for at the contract unit price per square yard for HOT-MIX ASPHALT DRIVEWAY PAVEMENT, thickness specified.

PAY ITEM #55 – BRICK DRIVEWAY REMOVAL AND REPLACEMENT

Description. This work shall consist of removing an existing brick driveway, cleaning and storing the bricks, excavating or placing embankment to meet the lines and grades shown on the plans, and replacing the bricks in the original pattern to the satisfaction of the Engineer. This work shall be completed in accordance with Sections 301 and 440 of the Standard Specifications, and as directed by the Engineer.

If the Contractor removes or damages the existing driveway outside the limits designated by the Engineer, the Contractor will be required to remove and replace that portion at the Contractor's own expense to the satisfaction of the Engineer. The existing material shall be carefully stored and replaced after the adjacent curb and gutter or sidewalk is completed. In some locations, the Contractor may have to provide additional material. The additional brick, pavers or flagstone must match the existing material and be approved by the Engineer before installation. The Contractor shall provide a 4" thick sand base or match the thickness of the existing base, whichever is greater. This work will not be paid for separately but shall be included in this pay item.

All excavation, embankment, brick, stone, aggregate base course, sand, and any other material required to match the existing brick driveway shall be included BRICK DRIVEWAY REMOVAL AND REPLACEMENT.

Method of Measurement and Basis of Payment. This work shall be measured and paid for at the contract unit price per square yard for BRICK DRIVEWAY REMOVAL AND REPLACEMENT.

PAY ITEM #56 – BRICK PAVER REMOVAL

Description. This work shall consist of removing an existing brick paver walkway, cleaning and storing the bricks at a location determined by the engineer, excavating or placing embankment to meet the lines and grades shown on the plans, and preparing the ground surface for landscape restoration to the satisfaction of the Engineer. This work shall be completed in accordance with Sections 301 and 440 of the Standard Specifications, and as directed by the Engineer.

If the Contractor removes or damages the existing brick pavers outside the limits designated by the Engineer, the Contractor will be required to remove and replace that portion at the Contractor's own expense. Once removed, the existing material shall be carefully stored at a location determined by the Engineer. Unless otherwise directed by the Engineer, the brick shall remain the property of property owner. If individual bricks are damaged during removal, the Contractor shall be responsible to furnish new individual bricks at the Contractor's own expense. The additional brick, pavers or flagstone must match the existing material and be approved by the Engineer.

All excavation, embankment, brick, stone, and any other material required to complete the work as specified shall be included BRICK PAVER REMOVAL.

Method of Measurement and Basis of Payment. This work shall be measured and paid for at the contract unit price per square yard for BRICK PAVER REMOVAL.

PAY ITEM #57 – STRUCTURE TO BE REMOVED

Description. This work shall consist of removing and disposing of existing manholes, catch basins, and inlets in accordance with Section 605 of the Standard Specifications and as specified herein. The word STRUCTURE shall be understood to mean manholes, catch basins and inlets as the case may be. Removal of existing structures in locations where new structures are to be installed shall be included in the cost of the proposed structure.

Construction Requirements. In addition to the requirements of Article 605.03 of the Standard Specifications, the Contractor shall saw cut a square area around the structure to be removed of sufficient size to remove the structure. Excavated areas around the structure shall be backfilled with mechanically compacted CA-6. This backfill shall be included in the cost for STRUCTURE TO BE REMOVED.

Method of Measurement and Basis of Payment. This work shall be measured and paid for at the contract unit price per each for STRUCTURES TO BE REMOVED.

PAY ITEM #58 – STORM SEWERS, CLASS B (PVC), 6”

Description. This work shall consist of constructing Polyvinyl Chloride (PVC) pipe storm sewers on granular bedding as shown on the plans in accordance with the detail in the plans, Sections 550 and 1040.03 of the Standard Specifications, and as specified herein.

Materials. Storm sewers shall be Polyvinyl Chloride (PVC) SDR 26 pipe in accordance with ASTM D2241 and Section 1040.03 of the Standard Specifications. Bedding material shall be crushed gravel or stone meeting gradation CA-7 or CA-11.

Construction Requirements. Storm sewers shall be installed on a minimum of 4-inches of granular bedding. Once the pipe has been installed the Contractor shall place bedding to 12-inches over the crown of the pipe. Bedding material will not be paid for separately but shall be included in the cost of this item. The Contractor shall connect the proposed storm sewer to existing storm sewer or a drainage structure at the direction of the Engineer. The method of connection shall be approved by the Engineer prior to construction. The connection of the proposed storm sewer to the drainage system shall be included in the cost of the proposed pipe.

If required by the Engineer, the Contractor shall stabilize the trench bottom by replacing unsuitable material with CA-1 limestone. This will not be paid for separately but shall be included in this item.

Trench backfill shall be placed over the bedding material and shall be paid for as TRENCH BACKFILL.

Method of Measurement and Basis of Payment. This work shall be measured and paid for at the contract unit price per lineal foot for STORM SEWERS, CLASS B (PVC), 6".

PAY ITEM #59 – SANITARY MANHOLE, TYPE A, 4'-DIAMETER, TYPE 1 FRAME, CLOSED LID

Description. This work shall consist of constructing manholes, together with the necessary cast iron frames and lids, in accordance with the detail in the plans and Section 602 of the STANDARD SPECIFICATIONS, except as specified herein.

Manholes constructed over proposed or existing sanitary sewers and which are indicated on the plans as sanitary manholes shall be provided with rubber gasketed couplings to ensure a watertight seal between pipe and manhole. The rubber gasketed couplings shall conform to ASTM Specification C-923. Manholes shall be provided with epoxy coated cast iron steps on 16" centers from frame to invert. The outside of the manhole shall be coated with a waterproofing membrane and external sealing bands conforming to ASTM C-877. The seal between the pipe and the structure to be bound by water tight hydraulic cement. The rubber gasketed couplings, waterproof coating, chimney seal, and steps shall be included in the cost of manholes and will not be paid for separately.

Manholes constructed in a location where an existing manhole was removed shall include five feet of pipe for each existing pipe location. Sanitary sewer pipe shall be PVC, SDR 26 conforming to ASTM D2241 or ductile iron, class 52, connections shall be made with non-shear mission couplings. The pipe, collar, couplings, and trench backfill shall be included in the cost of manholes and will not be paid for separately.

When a proposed manhole is to be installed at the location of an existing manhole, the removal of the existing structure shall be included in this item. Removing existing manholes shall consist of the removal and disposal of existing manholes in accordance with Section 605 of the Standard Specifications.

Method of Measurement and Basis of Payment. This work shall be paid for at the Contract unit price per each for SANITARY MANHOLE, TYPE A, 4' DIAMETER, TYPE 1 FRAME, CLOSED LID.

PAY ITEM #60 – SANITARY SERVICE CONNECTION

Description. This work shall consist of replacing existing sanitary service connections at locations of sanitary service removal and replacement. The work shall be done in accordance with applicable portions of Section 563 of the Standard Specifications and as specified herein.

2018 STREET IMPROVEMENTS VILLAGE OF VILLA PARK

The exact locations of existing sewer and sewer connections are to be verified in the field by the CONTRACTOR. The Village will not mark locations of existing sanitary services.

The CONTRACTOR shall install a new polyvinyl chloride tee fitting at the location of the connection to the existing sewer main, and shall remove and replace, if necessary, a sufficient length of existing service pipe to re-establish the service. All connections to existing pipes shall be made with non-shear mission couplings. The couplings shall be equipped with stainless steel bands. All associated costs shall be included in the contract unit price for the sanitary sewer service connection.

Basis of Payment. This work will be paid for at the contract unit price per each for SANITARY SERVICE CONNECTION.

PAY ITEM #61 – SANITARY SERVICE REPLACEMENT

Description: This work shall consist of the complete removal or abandonment of existing service as directed by the ENGINEER and replacing and reconnecting a new PVC SDR-26 (ASTM D2241) sanitary service to the existing sanitary sewer.

New sanitary service pipe should be cut in cleanly at the minimum distance from the conflicting improvement that provides for elimination of the conflict, or a location determined by the ENGINEER. A rubber, non-shear mission coupling with stainless steel bands should be used to effect the connection between new service and existing service pipes.

Sanitary services shall be connected to the existing sanitary sewer where shown on the plans. The exact locations of existing sewer and sewer connections are to be verified in the field by the CONTRACTOR. The Village will not mark locations of existing sanitary services, and the locating of existing services shall be the responsibility of the CONTRACTOR. The slope from the right-of-way to the sewer connection shall be continuous and constant, except as otherwise authorized by the ENGINEER. The CONTRACTOR shall be responsible for verifying the elevation and slope of the proposed service prior to the installation of each service.

The CONTRACTOR shall install a new polyvinyl chloride tee fitting at the location of the connection on the mainline sanitary sewer. Installation of this fitting shall be paid for as SANITARY SERVICE CONNECTION. The services shall be replaced from the new fitting at the mainline sanitary sewer to the right-of-way line, using SDR-26 polyvinyl chloride pipe conforming to ASTM D2241 of the same diameter as the existing connection. The CONTRACTOR is to ensure positive flow from the right-of-way to the connection to the mainline sewer.

Backfill shall be in accordance with Section 208 of the Standard Specifications and shall be paid for as TRENCH BACKFILL.

Method of Measurement and Basis of Payment. Pay limits for removal and replacement of sanitary services for this item shall extend from the connection at the sanitary main to the existing right-of-way. This work will be measured and paid for at the contract unit price per foot for SANITARY SERVICE REPLACEMENT.

PAY ITEM #62 – SANITARY SEWER SERVICE COMBINATION CLEANOUT CHECK VALVE

Description. This work shall consist of furnishing and installing a combination cleanout check valve on a new or existing sanitary sewer service line at the locations shown in the plans or as directed by the Engineer. This work shall be in accordance with Section 563 of the Standard Specifications and with the Standard Specifications for Water and Sewer Construction in Illinois, except as modified herein.

This work may consist of either the standalone installation of a combination cleanout check valve on an existing sanitary sewer service line, or the installation of a combination cleanout check valve on a new sanitary sewer service line in conjunction with the installation of the new sanitary sewer service line.

Materials. Combination cleanout check valves shall be RectorSeal Clean Check Extendable Backwater Valve, 6" PVC, Model #31805, or approved equal.

Cleanout riser pipes shall be shall be polyvinyl chloride (PVC) of the diameter and type required.

Sanitary sewer service line pipe shall be polyvinyl chloride (PVC) conforming to ASTM D-2241 with a Standard Dimension Ratio (SDR) equal to 26 and gasketed joints conforming to ASTM D-3212. Sanitary sewer service line pipe shall be of the same diameter as the sanitary sewer service line on which the combination cleanout check valve is to be installed. All supplied pipe shall be from the same manufacturer.

Pipe couplings shall be Fernco Shielded RC Series Couplings, Mission Rubber Company Flex-Seal ARC Sewer Repair Couplings, or approved equal. Pipe couplings shall be non-shear and shall be equipped with stainless steel bands.

Construction. The combination cleanout check valve shall be located a minimum of 4 ft. behind the back of curb. The height of the combination cleanout check valve riser pipe shall be such that the cap of the combination cleanout check valve is level with finished grade.

2018 STREET IMPROVEMENTS VILLAGE OF VILLA PARK

The combination cleanout check valve shall be assembled and installed in accordance with the manufacturer's specifications. Contractor shall provide all materials, fittings, and adapters necessary to assemble the combination cleanout check valve and to connect it to the sanitary sewer service line.

Following installation, the combination cleanout check valve shall be tested by the Contractor to confirm that there is positive flow through the sanitary sewer service line and combination cleanout check valve towards the sanitary sewer main.

Excavation, bedding, and backfilling will not be paid for separately but shall be included in the cost of this work.

Method of Measurement. This work will be measured for payment as each combination cleanout check valve installed, regardless of the depth, whether the cleanout check valve is installed on an existing sanitary sewer service line or a new sanitary sewer service line, or any other factors. No separate measurement will be made of pipe, fittings, couplings, other components.

Basis of Payment. This work will be paid for at the contract unit price per each for SANITARY SEWER SERVICE COMBINATION CLEANOUT CHECK VALVE.

PAY ITEM #63 & 64 – WATER SERVICE CONNECTION

Description. This work shall consist of installing new copper water service connections and lines, complete in place from the water main to the existing water service line behind the curb stop, as shown on the plans or as directed by the Engineer. This work shall be in accordance with Section 562 of the Standard Specifications and with the Standard Specifications for Water and Sewer Construction in Illinois, except as modified herein.

Short service connections shall be defined as those services for properties which are located adjacent to the half of the right-of-way where the water main is located. Long service connections shall be defined as those services for properties which are located adjacent to the half of the right-of-way opposite where the water main is located.

Materials. Water service line pipe shall be Type "K" seamless copper water tubing conforming to ASTM B88, of the diameter specified. The pipe shall be marked with the manufacturer's name or trademark and with markings indicating the type of the pipe.

Corporation stops shall be Mueller 300 Ball Corporation Valve Model B-25000 with AWWA taper (Mueller "CC") thread inlet and copper flare straight connection outlet.

Curb stops shall be Mueller 300 Ball Curb Valve Model B-25154 with copper flare nuts on both ends, quarter turn check, and Minneapolis pattern thread top.

2018 STREET IMPROVEMENTS VILLAGE OF VILLA PARK

Curb boxes shall be Mueller extension type curb box Model H-10302 with Minneapolis pattern base, 1-½ in. inside diameter, and 2-½ in. base tapping diameter.

Water service line couplings shall be Mueller H-15400 straight three-part unions with copper flare nuts on both ends, conforming to ANSI/AWWA C800, of the size needed.

All materials furnished as a part of this work shall comply with the latest requirements of the Federal Safe Drinking Water Act.

Construction. Where an existing water service is to be replaced, the contractor shall expose and remove the existing corporation stop. The contractor shall furnish a Smith-Blair circle repair sleeve of the appropriate diameter and of sufficient length and shall install it on the water main.

Contractor shall make a new connection to the water main using a tapping machine satisfactory to the Engineer. Contractor shall furnish and install a new corporation stop of the appropriate diameter on the water main. The Engineer may require that the Contractor furnish and install a tapping sleeve of the appropriate size if needed.

Contractor shall install a new water service line pipe from the corporation stop to the location of the existing curb box, or to such other location as shown in the plans or as directed by the Engineer. A single piece of copper water tubing of sufficient length to extend the full distance from the water main to the curb stop shall be utilized. Splicing of multiple sections of copper water tubing will not be permitted.

The new water service line and all components shall be installed a minimum of 5.5 ft. below finished grade. Where other utilities are encountered, the new water service line shall be located so that a minimum of 1 ft. of clearance exists in all directions between the new water service line and all other utilities. Where the new water service line crosses other utilities, if installation of the new water service line above the utility being crossed would result in any portion of the new water service line being less than 5.5 ft. below finished grade, the new water service line shall be installed below the utility being crossed.

The new water service line and all components shall be placed on a bedding of crushed aggregate of CA-7 or CA-11 gradation having a minimum thickness of 4 in. The bedding shall be placed to a minimum of 12 in. above the water service line.

Contractor shall furnish and install a new curb stop of the appropriate diameter. Contractor shall connect the new curb stop to the existing water service line behind the curb stop. If the existing water service line behind the curb stop is of a different material or diameter than the new water service line being installed, a section of new copper water service line shall be installed behind the curb stop. The existing water service line shall then be cut by an approved method, and the end of the existing water service line

2018 STREET IMPROVEMENTS VILLAGE OF VILLA PARK

shall be joined to the new water service line with a water service line coupling of the appropriate type and size.

Contractor shall furnish and install a new curb box. Contractor shall remove the existing curb box. Contractor shall install a piece of lathe or timber adjacent to the new curb box to identify its location until final restoration takes place. Contractor shall adjust the new curb box to finished grade immediately before the placement of sodding or seeding, or the completion of any other final restoration measures. Contractor shall then remove the lathe or timber.

In addition to all materials listed, Contractor shall also furnish and install all other necessary fittings, adapters, hardware, and materials necessary to complete the work as described.

Excavation, bedding, and backfilling of water service connections and lines will not be paid for separately, but shall be included in the cost of this work.

Method of Measurement. This work will be measured for payment as each water service connection and line installed, regardless of the length of the water service line, the depth of the water service line, conflicts with other utilities, or any other factors. No separate measurement will be made of pipe, fittings, couplings, stops, valves, or other components.

Basis of Payment. This work will be paid for at the contract unit price per each for WATER SERVICE CONNECTION (LONG), of the diameter specified, or WATER SERVICE CONNECTION (SHORT), of the diameter specified.

PAY ITEM #65 – WATER USAGE CREDIT

Description. Pay items are provided as a part of this contract for the purpose of documenting the quantity of water obtained from the Village by the Contractor.

If the Contractor elects to obtain water from the Village, the Contractor shall comply with the Special Provision USE OF FIRE HYDRANTS. The quantity of water obtained from the Village by the Contractor shall be deducted from the contract as WATER USAGE DEDUCTION, and shall be credited to the contract as WATER USAGE CREDIT.

The WATER USAGE CREDIT pay item for this contract has been established with a unit of measurement in thousands of gallons (TGAL), a quantity of one-hundred (100.00), and a contract unit price of eight dollars and eighty-five cents (\$8.85), for a total WATER USAGE CREDIT contract price of eight-hundred eighty-five dollars and no cents (\$885.00). Bidder, in submitting a bid, accepts the quantity, contract unit price, and total contract price of the WATER USAGE CREDIT pay item.

Method of Measurement. Water usage will be measured as the actual quantity of water obtained from the Village by the Contractor, which quantity shall be rounded up to the nearest 1,000 gallons.

Basis of Payment. The water usage credit will be paid for at the contract unit price per thousand gallons (TGAL) for WATER USAGE CREDIT. The quantity paid for as WATER USAGE CREDIT will be equal to the quantity deducted as WATER USAGE DEDUCTION.

PAY ITEM #66 – WATER USAGE DEDUCTION

Description. Pay items are provided as a part of this contract for the purpose of documenting the quantity of water obtained from the Village by the Contractor.

If the Contractor elects to obtain water from the Village, the Contractor shall comply with the Special Provision USE OF FIRE HYDRANTS. The quantity of water obtained from the Village by the Contractor shall be deducted from the contract as WATER USAGE DEDUCTION, and shall be credited to the contract as WATER USAGE CREDIT.

The WATER USAGE DEDUCTION pay item for this contract has been established with a unit of measurement in thousands of gallons (TGAL), a quantity of one-hundred (100.00), and a contract unit price of a deduction of eight dollars and eighty-five cents (\$8.85), for a total WATER USAGE DEDUCTION contract price of a deduction of eight-hundred eighty-five dollars and no cents (\$885.00). Bidder, in submitting a bid, accepts the quantity, contract unit price, and total contract price of the WATER USAGE DEDUCTION pay item.

Method of Measurement. Water usage will be measured as the actual quantity of water obtained from the Village by the Contractor, which quantity shall be rounded up to the nearest 1,000 gallons.

Basis of Payment. The water usage deduction will be deducted at the contract unit price per thousand gallons (TGAL) for WATER USAGE DEDUCTION. The quantity deducted as WATER USAGE DEDUCTION will be equal to the quantity paid for as WATER USAGE CREDIT.

PAY ITEM #67 – PRE-CONSTRUCTION VIDEO RECORDING

Description. This work shall consist of performing color video and audio recording of the project area and other areas which may be impacted by construction.

Pre-construction video recordings will include coverage of the project area and all other areas which may be impacted by construction. Video recordings will also include

2018 STREET IMPROVEMENTS VILLAGE OF VILLA PARK

construction easements when applicable. Video recordings will provide a visual record of all physical features within those areas, including, but not limited to, roadways, pavements, curbs, gutters, driveways, driveway aprons, sidewalks, carriage walks, parkways, trees, landscaping, shrubbery, plantings, landscaping walls, retaining walls, signs, sign posts, fences, utility poles, light poles, utilities, equipment, manholes, b-boxes, cleanouts, valves, curb structures, pipelines, buildings, mailboxes, and any other features located within the project area.

Video recordings will begin with an audio narrative which provides the current date and time, the name of the Village and name of project, and a description of both the starting location and the location or locations to be recorded, including street name or names, street addresses, and any additional information which may be necessary to describe the location and subject of viewing.

Video recordings will maintain viewer orientation by means of an audio commentary in the audio track of each video recording which provides an explanation of what is being viewed; and by videotaping landmarks and readily identifiable objects, including property addresses, street signs, or other appropriate objects, at appropriate intervals.

Pre-construction video recordings will be recorded at a rate of travel not exceeding 50 feet per minute, and zooming and panning rates will be controlled to provide clarity of features during playback. The finished product will be provided with bright, clear pictures and accurate colors free from distortion, tearing, rolls, or other forms of picture imperfection. The audio will have proper volume and clarity. All recordings will be performed at times of satisfactory visibility, and when no more than 10 percent of ground is obscured by snow, leaves, or other cover.

If any element within or portion of the project area is not adequately documented by the pre-construction video recording so as to definitively demonstrate its condition prior to the start of construction, Contractor will assume responsibility for the repair, restoration or replacement of that element or portion of the project area. Such repair, restoration or replacement will be to equal or better condition than previously existing, and will further comply with all standards and provisions which govern the work in question.

Schedule. Preconstruction video recording will be performed according to the following schedule:

- (a) Pre-construction video recording will be completed after a Notice to Proceed has been issued.
- (b) Pre-construction video recording will be completed after the Joint Utility Locating Information for Excavators (JULIE) request for the project area has cleared.

**2018 STREET IMPROVEMENTS
VILLAGE OF VILLA PARK**

- (c) Pre-construction video recording will be completed before any equipment, materials, or other items are delivered to the site.
- (d) Pre-construction video recording will be completed no more than 7 chargeable days prior to the start of construction.
- (e) Pre-construction video recording will be completed, the required pre-construction video recording deliverables will be submitted to the Engineer, and the Engineer will review and issue written approval of the pre-construction video recording before any activity other than utility locating will be permitted to start. Such activity will include, but not be limited to, delivery of materials and equipment, installation of traffic control and erosion control, and completion of construction layout and tree protection. No days will be charged against the contract time while the video is under review by the Engineer, including the day the deliverables are submitted and the day a response is provided. If the pre-construction video recording or any portions thereof are rejected, the contract time will commence to run until revisions are submitted.
- (f) Pre-construction video recording will be submitted to Engineer for review prior to commencement of any construction, and receive acceptance of recordings prior to commencement of construction. Any areas found not acceptable to the Owner will be re-recorded at no additional cost to the contract.

Deliverables. Video will be high-definition, with a minimum resolution of 1280 × 720 pixels per frame. Video will be filmed in a landscape aspect ratio. Video filmed in a portrait aspect ratio will be considered unacceptable and will be rejected.

Preconstruction video recordings will be provided as electronic files of .avi, .mp4, .m4v, .mkv, .wmv, or .mpg file format, or of such other file format as may be approved by Engineer. Preconstruction video recordings will be provided as independent digital container format files, which container files will include all video, audio, and other electronic information necessary to view the preconstruction video recording as intended.

Video DVD will be considered an unacceptable format for providing preconstruction video recordings, and will be rejected.

Pre-construction video recording electronic files will be provided on a portable electronic media device or devices of one of the following types: USB flash drive, SD flash memory card, CF flash memory card, data DVD, external hard drive, or such other portable electronic media device as may be approved by Engineer. Preconstruction video recording electronic files may also be provided via online file sharing, cloud storage, File Transfer Protocol (FTP), or other online or network file transfer methods if approved by Engineer.

Pre-construction video recording electronic files will be accompanied by corresponding logs which document the dates, times, and locations covered by each preconstruction video recording electronic file.

Contractor shall maintain copies of all items submitted to Engineer for Contractor's own use and record.

Method of Measurement. This work will be measured for payment on a lump sum basis. No measurement will be made of the individual components of this effort.

Basis of Payment. Pre-construction video recording will be paid for at the contract lump sum price for PRE-CONSTRUCTION VIDEO RECORDING.

PAY ITEM #68 – CONTINGENCY ALLOWANCE

Description. A contingency allowance pay item is provided as a part of this contract for the purpose of facilitating the completion of unforeseen or additional work not included in the contract as awarded, and which is determined by the Engineer to be necessary and germane to the contract.

Use of the contingency allowance will be at the discretion of the Engineer. The Engineer may, at the Engineer's discretion, use the contingency allowance for any of the following reasons:

- (a) Facilitate a temporary payment allowance to the Contractor for work completed under existing contract pay items and for which completed quantities exceed contract quantities;
- (b) Facilitate a temporary payment allowance to the Contractor for work completed beyond the scope of existing contract pay items; or
- (c) Facilitate a temporary payment allowance to the Contractor for the purchase of equipment, materials or such other requisition as Engineer determines to be necessary for the completion of the Work.

Such use of the CONTINGENCY ALLOWANCE will be further subject to approval by the Village. The Village's decision with regard to use of the CONTINGENCY ALLOWANCE will be final.

- A. Any payments made to Contractor under the CONTINGENCY ALLOWANCE will be considered temporary, and will only be retained by Contractor until such time that an authorization of contract changes can be approved and incorporated into the contract.

**2018 STREET IMPROVEMENTS
VILLAGE OF VILLA PARK**

- B. Contractor, in accepting payments made under the CONTINGENCY ALLOWANCE, agrees to the terms of this and other applicable special provisions. Contractor agrees to relinquish any monies and any claim to monies paid under the CONTINGENCY ALLOWANCE upon approval of an authorization of contract changes and payment for any work for which payment was previously made under the CONTINGENCY ALLOWANCE. Contractor further agrees to return any monies previously paid thereunder.
- C. The CONTINGENCY ALLOWANCE pay item for the base bid of this contract has been established with a unit of measurement in dollars, a quantity of 50,000.00, and a contract unit price of one dollar (\$1.00), for a total CONTINGENCY ALLOWANCE contract price of fifty thousand dollars and no cents (\$50,000.00). Each Alternate bid (1-4) shall have a quantity of 5,000.00 and a contract unit price of one dollar (\$1.00), for a total CONTINGENCY ALLOWANCE price of five thousand dollars and no cents (\$5,000). Bidder, in submitting a bid, accepts the quantity, contract unit price, and total contract price of the CONTINGENCY ALLOWANCE.

Basis of Payment. This work will be paid for at the contract unit price per dollar for CONTINGENCY ALLOWANCE. The total bid amounts for this item will be as follows:

Base Bid:	\$50,000.00
Alternate 1:	\$5,000.00
Alternate 2:	\$5,000.00
Alternate 3:	\$5,000.00
Alternate 4:	\$5,000.00

ADJUSTMENTS AND RECONSTRUCTIONS

Effective: March 15, 2011

Revise the first paragraph of Article 602.04 to read:

“602.04 Concrete. Cast-in-place concrete for structures shall be constructed of Class SI concrete according to the applicable portions of Section 503. Cast-in-place concrete for pavement patching around adjustments and reconstructions shall be constructed of Class PP-1 concrete, unless otherwise noted in the plans, according to the applicable portions of Section 1020.”

Revise the third, fourth and fifth sentences of the second paragraph of Article 602.11(c) to read:

“Castings shall be set to the finished pavement elevation so that no subsequent adjustment will be necessary, and the space around the casting shall be filled with Class PP-1 concrete, unless otherwise noted in the plans, to the elevation of the surface of the base course or binder course. HMA surface or binder course material shall not be allowed. The pavement may be opened to traffic according to Article 701.17(e)(3)b.”

Revise Article 603.05 to read:

“603.05 Replacement of Existing Flexible Pavement. After the castings have been adjusted, the surrounding space shall be filled with Class PP-1 concrete, unless otherwise noted in the plans, to the elevation of the surface of the base course or binder course. HMA surface or binder course material shall not be allowed. The pavement may be opened to traffic according to Article 701.17(e)(3)b.”

Revise Article 603.06 to read:

“603.06 Replacement of Existing Rigid Pavement. After the castings have been adjusted, the pavement and HMA that was removed, shall be replaced with Class PP-1 concrete, unless otherwise noted in the plans, not less than 9 in. (225 mm) thick. The pavement may be opened to traffic according to Article 701.17(e)(3)b.

The surface of the Class PP concrete shall be constructed flush with the adjacent surface.”

Revise the first sentence of Article 603.07 to read:

“603.07 Protection Under Traffic. After the casting has been adjusted and the Class PP concrete has been placed, the work shall be protected by a barricade and two lights according to Article 701.17(e)(3)b.”

**2018 STREET IMPROVEMENTS
VILLAGE OF VILLA PARK**

FRICITION AGGREGATE (D-1)

Effective: January 1, 2011

Revised: April 29, 2016

Revise Article 1004.03(a) of the Standard Specifications to read:

“1004.03 Coarse Aggregate for Hot-Mix Asphalt (HMA). The aggregate shall be according to Article 1004.01 and the following.

(a) Description. The coarse aggregate for HMA shall be according to the following table.

Use	Mixture	Aggregates Allowed
Class A	Seal or Cover	<u>Allowed Alone or in Combination</u> ^{5/} : Gravel Crushed Gravel Carbonate Crushed Stone Crystalline Crushed Stone Crushed Sandstone Crushed Slag (ACBF) Crushed Steel Slag Crushed Concrete
HMA Low ESAL	Stabilized Subbase Shoulders or	<u>Allowed Alone or in Combination</u> ^{5/} : Gravel Crushed Gravel Carbonate Crushed Stone Crystalline Crushed Stone Crushed Sandstone Crushed Slag (ACBF) Crushed Steel Slag ^{1/} Crushed Concrete
HMA High ESAL Low ESAL	Binder IL-19.0 or IL-19.0L SMA Binder	<u>Allowed Alone or in Combination</u> ^{5/ 6/} : Crushed Gravel Carbonate Crushed Stone ^{2/} Crystalline Crushed Stone Crushed Sandstone Crushed Slag (ACBF) Crushed Concrete ^{3/}

**2018 STREET IMPROVEMENTS
VILLAGE OF VILLA PARK**

Use	Mixture	Aggregates Allowed						
HMA High ESAL Low ESAL	C Surface and Leveling Binder IL-9.5 or IL-9.5L	<u>Allowed Alone or in Combination</u> ^{5/} : Crushed Gravel Carbonate Crushed Stone ^{2/} Crystalline Crushed Stone Crushed Sandstone						
	SMA Ndesign 50 Surface	Crushed Slag (ACBF) Crushed Steel Slag ^{4/} Crushed Concrete ^{3/}						
HMA High ESAL	D Surface and Leveling Binder IL-9.5 SMA Ndesign 50 Surface	<u>Allowed Alone or in Combination</u> ^{5/} : Crushed Gravel Carbonate Crushed Stone (other than Limestone) ^{2/} Crystalline Crushed Stone Crushed Sandstone Crushed Slag (ACBF) Crushed Steel Slag ^{4/} Crushed Concrete ^{3/}						
		<u>Other Combinations Allowed:</u> <table border="1"> <thead> <tr> <th><i>Up to...</i></th> <th><i>With...</i></th> </tr> </thead> <tbody> <tr> <td>25% Limestone</td> <td>Dolomite</td> </tr> <tr> <td>50% Limestone</td> <td>Any Mixture D aggregate other than Dolomite</td> </tr> <tr> <td>75% Limestone</td> <td>Crushed Slag (ACBF) or Crushed Sandstone</td> </tr> </tbody> </table>	<i>Up to...</i>	<i>With...</i>	25% Limestone	Dolomite	50% Limestone	Any Mixture D aggregate other than Dolomite
<i>Up to...</i>	<i>With...</i>							
25% Limestone	Dolomite							
50% Limestone	Any Mixture D aggregate other than Dolomite							
75% Limestone	Crushed Slag (ACBF) or Crushed Sandstone							
HMA High ESAL	E Surface IL-9.5 SMA Ndesign 80 Surface	<u>Allowed Alone or in Combination</u> ^{5/ 6/} : Crystalline Crushed Stone Crushed Sandstone Crushed Slag (ACBF) Crushed Steel Slag No Limestone.						
		<u>Other Combinations Allowed:</u> <table border="1"> <thead> <tr> <th><i>Up to...</i></th> <th><i>With...</i></th> </tr> </thead> <tbody> <tr> <td>50% Dolomite^{2/}</td> <td>Any Mixture E aggregate</td> </tr> </tbody> </table>	<i>Up to...</i>	<i>With...</i>	50% Dolomite ^{2/}	Any Mixture E aggregate		
<i>Up to...</i>	<i>With...</i>							
50% Dolomite ^{2/}	Any Mixture E aggregate							

**2018 STREET IMPROVEMENTS
VILLAGE OF VILLA PARK**

Use	Mixture	Aggregates Allowed	
		75% Dolomite ^{2/}	Crushed Sandstone, Crushed Slag (ACBF), Crushed Steel Slag, or Crystalline Crushed Stone
		75% Crushed Gravel ^{2/} or Crushed Concrete ^{3/}	Crushed Sandstone, Crystalline Crushed Stone, Crushed Slag (ACBF), or Crushed Steel Slag
HMA High ESAL	F Surface IL-9.5 SMA Ndesign 80 Surface	<u>Allowed Alone or in Combination</u> ^{5/ 6/} :	
		Crystalline Crushed Stone Crushed Sandstone Crushed Slag (ACBF) Crushed Steel Slag No Limestone.	
		<u>Other Combinations Allowed:</u>	
		<i>Up to...</i>	<i>With...</i>
50% Crushed Gravel ^{2/} , Crushed Concrete ^{3/} , or Dolomite ^{2/}	Crushed Sandstone, Crushed Slag (ACBF), Crushed Steel Slag, or Crystalline Crushed Stone		

1/ Crushed steel slag allowed in shoulder surface only.

2/ Carbonate crushed stone (limestone) and/or crushed gravel shall not be used in SMA Ndesign 80. In SMA Ndesign 50, carbonate crushed stone shall not be blended with any of the other aggregates allowed alone in Ndesign 50 SMA binder or Ndesign 50 SMA surface.

3/ Crushed concrete will not be permitted in SMA mixes.

**2018 STREET IMPROVEMENTS
VILLAGE OF VILLA PARK**

- 4/ Crushed steel slag shall not be used as leveling binder.
- 5/ When combinations of aggregates are used, the blend percent measurements shall be by volume.”
- 6/ Combining different types of aggregate will not be permitted in SMA Ndesign 80.”

GROUND TIRE RUBBER (GTR) MODIFIED ASPHALT BINDER (D-1)

Effective: June 26, 2006

Revised: April 1, 2016

Add the following to the end of article 1032.05 of the Standard Specifications:

“(c) Ground Tire Rubber (GTR) Modified Asphalt Binder. A quantity of 10.0 to 14.0 percent GTR (Note 1) shall be blended by dry unit weight with a PG 64-28 to make a GTR 70-28 or a PG 58-28 to make a GTR 64-28. The base PG 64-28 and PG 58-28 asphalt binders shall meet the requirements of Article 1032.05(a). Compatible polymers may be added during production. The GTR modified asphalt binder shall meet the requirements of the following table.

Test	Asphalt Grade 70-28	Asphalt Grade GTR 64-28
Flash Point (C.O.C.), AASHTO T 48, °F (°C), min.	450 (232)	450 (232)
Rotational Viscosity, AASHTO T 316 @ 275 °F (135 °C), Poises, Pa·s, max.	30 (3)	30 (3)
Softening Point, AASHTO T 53, °F (°C), min.	135 (57)	130 (54)
Elastic Recovery, ASTM D 6084, Procedure A (sieve waived) @ 77 °F, (25 °C), aged, ss, 100 mm elongation, 5 cm/min., cut immediately, %, min.	65	65

Note 1. GTR shall be produced from processing automobile and/or light truck tires by the ambient grinding method. GTR shall not exceed 1/16 in. (2 mm) in any dimension and shall contain no free metal particles or other materials. A mineral powder (such as talc) meeting the requirements of AASHTO M 17 may be added, up to a maximum of four percent by weight of GTR to reduce sticking and caking of the GTR particles.

**2018 STREET IMPROVEMENTS
VILLAGE OF VILLA PARK**

When tested in accordance with Illinois modified AASHTO T 27, a 50 g sample of the GTR shall conform to the following gradation requirements:

Sieve Size	Percent Passing
No. 16 (1.18 mm)	100
No. 30 (600 μm)	95 ± 5
No. 50 (300 μm)	> 20

Add the following to the end of Note 1. of article 1030.03 of the Standard Specifications:

“A dedicated storage tank for the Ground Tire Rubber (GTR) modified asphalt binder shall be provided. This tank must be capable of providing continuous mechanical mixing throughout by continuous agitation and recirculation of the asphalt binder to provide a uniform mixture. The tank shall be heated and capable of maintaining the temperature of the asphalt binder at 300 °F to 350 °F (149 °C to 177 °C). The asphalt binder metering systems of dryer drum plants shall be calibrated with the actual GTR modified asphalt binder material with an accuracy of ± 0.40 percent.”

Revise 1030.02(c) of the Standard Specifications to read:

“(c) RAP Materials (Note 5)1031”

Add the following note to 1030.02 of the Standard Specifications:

Note 5. When using reclaimed asphalt pavement and/or reclaimed asphalt shingles, the maximum asphalt binder replacement percentage shall be according to the most recent special provision for recycled materials.

HMA MIXTURE DESIGN REQUIREMENTS (D-1)

Effective: January 1, 2013

Revised: April 1, 2016

1) Design Composition and Volumetric Requirements

Revise the table in Article 406.06(d) of the Standard Specifications to read:

**2018 STREET IMPROVEMENTS
VILLAGE OF VILLA PARK**

"MINIMUM COMPACTED LIFT THICKNESS	
Mixture Composition	Thickness, in. (mm)
IL-4.75	3/4 (19)
SMA-9.5, IL-9.5, IL-9.5L	1 1/2 (38)
SMA-12.5	2 (50)
IL-19.0, IL-19.0L	2 1/4 (57)"

Revise the table in Article 1004.03(c) of the Standard Specifications to read:

"Use	Size/Application	Gradation No.
Class A-1, 2, & 3 Seal	3/8 in. (10 mm)	CA 16
Class A-1 Seal	1/2 in. (13 mm)	CA 15
Class A-2 & 3 Cover		CA 14
HMA High ESAL	IL-19.0 IL-9.5	CA 11 ^{1/} CA 16, CA 13 ^{3/}
HMA Low ESAL	IL-19.0L IL-9.5L Stabilized Subbase or Shoulders	CA 11 ^{1/} CA 16
SMA ^{2/}	1/2 in. (12.5mm) Binder & Surface IL 9.5 Surface	CA13 ^{3/} , CA14 or CA16 CA16, CA 13 ^{3/}

1/ CA 16 or CA 13 may be blended with the gradations listed.

2/ The coarse aggregates used shall be capable of being combined with stone sand, slag sand, or steel slag sand meeting the FA/FM 20 gradation and mineral filler to meet the approved mix design and the mix requirements noted herein.

3/ CA 13 shall be 100 percent passing the 1/2 in. (12.5mm) sieve.

Revise Article 1004.03(e) of the Supplemental Specifications to read:

“(e) Absorption. For SMA the coarse aggregate shall also have water absorption
 ≤ 2.0 percent.”

**2018 STREET IMPROVEMENTS
VILLAGE OF VILLA PARK**

Revise the last paragraph of Article 1102.01 (a) (5) of the Standard Specifications to read:

“IL-4.75 and Stone Matrix Asphalt (SMA) mixtures which contain aggregate having absorptions greater than or equal to 2.0 percent, or which contain steel slag sand, shall have minimum surge bin storage plus haul time of 1.5 hours.”

Revise the nomenclature table in Article 1030.01 of the Standard Specifications to read:

“High ESAL	IL-19.0 binder; IL-9.5 surface; IL-4.75; SMA-12.5, SMA-9.5
Low ESAL	IL-19.0L binder; IL-9.5L surface; Stabilized Subbase (HMA) ^{1/} ; HMA Shoulders ^{2/}

1/ Uses 19.0L binder mix.

2/ Uses 19.0L for lower lifts and 9.5L for surface lift.”

Revise Article 1030.02 of the Standard Specifications and Supplemental Specifications to read:

“**1030.02 Materials.** Materials shall be according to the following.

Item	Article/Section
(a)	Coarse Aggregate 1004.03
(b)	Fine Aggregate 1003.03
(c)	RAP Material 1031
(d)	Mineral Filler 1011
(e)	Hydrated Lime 1012.01
(f)	Slaked Quicklime (Note 1)
(g)	Performance Graded Asphalt Binder (Note 2) 1032
(h)	Fibers (Note 3)

**2018 STREET IMPROVEMENTS
VILLAGE OF VILLA PARK**

(i) Warm Mix Asphalt (WMA) Technologies (Note 4)

Note 1. Slaked quicklime shall be according to ASTM C 5.

Note 2. The asphalt binder shall be an SBS PG 76-28 when the SMA is used on a full-depth asphalt pavement and SBS PG 76-22 when used as an overlay, except where modified herein. The asphalt binder shall be an Elvaloy or SBS PG 76-22 for IL-4.75, except where modified herein. The elastic recovery shall be a minimum of 80.

Note 3. A stabilizing additive such as cellulose or mineral fiber shall be added to the SMA mixture according to Illinois Modified AASHTO M 325. The stabilizing additive shall meet the Fiber Quality Requirements listed in Illinois Modified AASHTO M 325. Prior to approval and use of fibers, the Contractor shall submit a notarized certification by the producer of these materials stating they meet these requirements. Reclaimed Asphalt Shingles (RAS) may be used in Stone Matrix Asphalt (SMA) mixtures designed with an SBA polymer modifier as a fiber additive if the mix design with RAS included meets AASHTO T305 requirements. The RAS shall be from a certified source that produces either Type I or Type 2. Material shall meet requirements noted herein and the actual dosage rate will be determined by the Engineer.

Note 4. Warm mix additives or foaming processes shall be selected from the current Bureau of Materials and Physical Research Approved List, "Warm Mix Asphalt Technologies".

Revise Article 1030.04(a)(1) of the Standard Specifications and the Supplemental Specifications to read:

" (1) High ESAL Mixtures. The Job Mix Formula (JMF) shall fall within the following limits.

High ESAL, MIXTURE COMPOSITION (% PASSING) ^{1/}										
Sieve Size	IL-19.0 mm		SMA ^{4/} IL-12.5 mm		SMA ^{4/} IL-9.5 mm		IL-9.5 mm		IL-4.75 mm	
	min	max	min	max	min	max	min	max	min	max
1 1/2 in. (37.5 mm)										
1 in. (25 mm)		100								
3/4 in. (19 mm)	90	100		100						
1/2 in. (12.5 mm)	75	89	80	100		100		100		100
3/8 in. (9.5 mm)				65	90	100	90	100		100
#4 (4.75 mm)	40	60	20	30	36	50	34	69	90	100
#8 (2.36 mm)	20	42	16	24 ^{5/}	16	32 ^{5/}	34 ^{6/}	52 ^{2/}	70	90

**2018 STREET IMPROVEMENTS
VILLAGE OF VILLA PARK**

#16 (1.18 mm)	15	30					10	32	50	65
#30 (600 μm)			12	16	12	18				
#50 (300 μm)	6	15					4	15	15	30
#100 (150 μm)	4	9					3	10	10	18
#200 (75 μm)	3	6	7.0	9.0 ^{3/}	7.5	9.5 ^{3/}	4	6	7	9 ^{3/}
Ratio Dust/Asphalt Binder		1.0		1.5		1.5		1.0		1.0

- 1/ Based on percent of total aggregate weight.
- 2/ The mixture composition shall not exceed 44 percent passing the #8 (2.36 mm) sieve for surface courses with Ndesign = 90.
- 3/ Additional minus No. 200 (0.075 mm) material required by the mix design shall be mineral filler, unless otherwise approved by the Engineer.
- 4/ The maximum percent passing the #635 (20 μm) sieve shall be ≤ 3 percent.
- 5/ When establishing the Adjusted Job Mix Formula (AJMF) the percent passing the #8 (2.36 mm) sieve shall not be adjusted above the percentage stated on the table.
- 6/ When establishing the Adjusted Job Mix Formula (AJMF) the percent passing the #8 (2.36 mm) sieve shall not be adjusted below 34 percent.

Revise Article 1030.04(b)(1) of the Standard Specifications to read:

“(1) High ESAL Mixtures. The target value for the air voids of the HMA shall be 4.0 percent and for IL-4.75 it shall be 3.5 percent at the design number of gyrations. The VMA and VFA of the HMA design shall be based on the nominal maximum size of the aggregate in the mix, and shall conform to the following requirements.

<p>VOLUMETRIC REQUIREMENTS High ESAL</p>

**2018 STREET IMPROVEMENTS
VILLAGE OF VILLA PARK**

	Voids in the Mineral Aggregate (VMA), % minimum			Voids Filled with Asphalt Binder (VFA), %
Ndesign	IL-19.0	IL-9.5	IL-4.75 ^{1/}	
50	13.5	15.0	18.5	65 – 78 ^{2/}
70			65 - 75	
90				

1/ Maximum Draindown for IL-4.75 shall be 0.3 percent

2/ VFA for IL-4.75 shall be 72-85 percent”

Replace Article 1030.04(b)(3) of the Standard Specifications with the following:

“(3) SMA Mixtures.

Volumetric Requirements SMA ^{1/}				
Ndesign	Design Air Voids Target %	Voids in the Mineral Aggregate (VMA), % min.		Voids Filled with Asphalt (VFA), %
80 ^{4/}	3.5	17.0 ^{2/}		75 - 83
		16.0 ^{3/}		

1/ Maximum draindown shall be 0.3 percent. The draindown shall be determined at the JMF asphalt binder content at the mixing temperature plus 30 °F.

2/ Applies when specific gravity of coarse aggregate is ≥ 2.760.

3/ Applies when specific gravity of coarse aggregate is < 2.760.

4/ Blending of different types of aggregate will not be permitted.

For surface course, the coarse aggregate can be crushed steel slag, crystalline crushed stone or crushed sandstone. For binder course, coarse aggregate shall be crushed stone (dolomite), crushed gravel, crystalline crushed stone, or crushed sandstone.

Add to the end of Article 1030.05 (d) (2) a. of the Standard Specifications:

“During production, the Contractor shall test SMA mixtures for draindown according to AASHTO T305 at a frequency of 1 per day of production.”

Delete last sentence of the second paragraph of Article 1102.01(a) (4) b. 2.

Add to the end of Article 1102.01 (a) (4) b. 2.:

“As an option, collected dust (baghouse) may be used in lieu of manufactured mineral filler according to the following:

(a.) Sufficient collected dust (baghouse) is available for production of the SMA mix for the entire project.

(b.) A mix design was prepared based on collected dust (baghouse).

2) Design Verification and Production

Revise Article 1030.04 (d) of the Standard Specifications to read:

“(d) Verification Testing. High ESAL, IL-4.75, and SMA mix designs submitted for verification will be tested to ensure that the resulting mix designs will pass the required criteria for the Hamburg Wheel Test (IL mod AASHTO T-324) and the Tensile Strength Test (IL mod AASHTO T-283). The Department will perform a verification test on gyratory specimens compacted by the Contractor. If the mix fails the Department’s verification test, the Contractor shall make the necessary changes to the mix and resubmit compacted specimens to the Department for verification. If the mix fails again, the mix design will be rejected.

All new and renewal mix designs will be required to be tested, prior to submittal for Department verification and shall meet the following requirements:

- (1) Hamburg Wheel Test criteria. The maximum allowable rut depth shall be 0.5 in. (12.5 mm). The minimum number of wheel passes at the 0.5 in. (12.5 mm) rut depth criteria shall be based on the high temperature binder grade of the mix as specified in the mix requirements table of the plans.

Illinois Modified AASHTO T 324 Requirements ^{1/}

Asphalt Binder Grade	# Repetitions	Max Rut Depth (mm)
PG 70 -XX (or	20,000	12.5

**2018 STREET IMPROVEMENTS
VILLAGE OF VILLA PARK**

higher)		
PG 64 -XX (or lower)	10,000	12.5

- 1/ When produced at temperatures of 275 ± 5 °F (135 ± 3 °C) or less, loose Warm Mix Asphalt shall be oven aged at 270 ± 5 °F (132 ± 3 °C) for two hours prior to gyratory compaction of Hamburg Wheel specimens.

Note: For SMA Designs (N-80) the maximum rut depth is 6.0 mm at 20,000 repetitions.

For IL 4.75mm Designs (N-50) the maximum rut depth is 9.0mm at 15,000 repetitions.

(2) Tensile Strength Criteria. The minimum allowable conditioned tensile strength shall be 60 psi (415 kPa) for non-polymer modified performance graded (PG) asphalt binder and 80 psi (550 kPa) for polymer modified PG asphalt binder. The maximum allowable unconditioned tensile strength shall be 200 psi (1380 kPa)."

Production Testing. Revise first paragraph of Article 1030.06(a) of the Standard Specifications to read:

"(a) High ESAL, IL-4.75, WMA, and SMA Mixtures. For each contract, a 300 ton (275 metric tons) test strip, except for SMA mixtures it will be 400 ton (363 metric ton), will be required at the beginning of HMA production for each mixture with a quantity of 3000 tons (2750 metric tons) or more according to the Manual of Test Procedures for Materials "Hot Mix Asphalt Test Strip Procedures".

Add the following after the sixth paragraph in Article 1030.06 (a) of the Standard Specifications:

"The Hamburg Wheel test shall also be conducted on all HMA mixtures from a sample taken within the first 500 tons (450 metric tons) on the first day of production or during start up with a split reserved for the Department. The mix sample shall be tested according to the Illinois Modified AASHTO T 324 and shall meet the requirements specified herein. Mix production shall not exceed 1500 tons (1350 metric tons) or one day's production, whichever comes first, until the testing is completed and the mixture is found to be in conformance. The requirement to cease mix production may be waived if the plant produced mixture demonstrates conformance prior to start of mix production for a contract.

If the mixture fails to meet the Hamburg Wheel criteria, no further mixture will be accepted until the Contractor takes such action as is necessary to furnish a mixture meeting the criteria"

Method of Measurement:

Add the following after the fourth paragraph of Article 406.13 (b):

“The plan quantities of SMA mixtures shall be adjusted using the actual approved binder and surface Mix Design’s G_{mb} .”

Basis of Payment.

Replace the fourth paragraph of Article 406.14 of the Standard Specifications with the following:

“Stone matrix asphalt will be paid for at the contract unit price per ton (metric ton) for POLYMERIZED HOT-MIX ASPHALT SURFACE COURSE, STONE MATRIX ASPHALT, of the mixture composition and Ndesign specified; and POLYMERIZED HOT-MIX ASPHALT BINDER COURSE, STONE MATRIX ASPHALT, of the mixture composition and Ndesign specified.”

RECLAIMED ASPHALT PAVEMENT AND RECLAIMED ASPHALT SHINGLES (D-1)

Effective: November 1, 2012

Revise: January 1, 2018

Revise Section 1031 of the Standard Specifications to read:

“SECTION 1031. RECLAIMED ASPHALT PAVEMENT AND RECLAIMED ASPHALT SHINGLES

1031.01 Description. Reclaimed asphalt pavement and reclaimed asphalt shingles shall be according to the following.

- (a) Reclaimed Asphalt Pavement (RAP). RAP is the material resulting from cold milling or crushing an existing hot-mix asphalt (HMA) pavement. RAP will be considered processed FRAP after completion of both crushing and screening to size. The Contractor shall supply written documentation that the RAP originated from routes or airfields under federal, state, or local agency jurisdiction.
- (b) Reclaimed Asphalt Shingles (RAS). Reclaimed asphalt shingles (RAS). RAS is from the processing and grinding of preconsumer or post-consumer shingles. RAS shall be a clean and uniform material with a maximum of 0.5 percent unacceptable material, as defined in Central Bureau of Materials Policy Memorandum, “Reclaimed Asphalt Shingle (RAS) Sources”, by weight of RAS. All RAS used shall come from a Central Bureau of Materials approved processing facility where it shall be ground and processed to 100 percent passing the 3/8 in. (9.5 mm) sieve and 90 percent passing the #4 (4.75 mm)

**2018 STREET IMPROVEMENTS
VILLAGE OF VILLA PARK**

sieve. RAS shall meet the testing requirements specified herein. In addition, RAS shall meet the following Type 1 or Type 2 requirements.

- (1) Type 1. Type 1 RAS shall be processed, preconsumer asphalt shingles salvaged from the manufacture of residential asphalt roofing shingles.
- (2) Type 2. Type 2 RAS shall be processed post-consumer shingles only, salvaged from residential, or four unit or less dwellings not subject to the National Emission Standards for Hazardous Air Pollutants (NESHAP).

1031.02 Stockpiles. RAP and RAS stockpiles shall be according to the following.

(a) RAP Stockpiles. The Contractor shall construct individual, sealed RAP stockpiles meeting one of the following definitions. Additional processed RAP (FRAP) shall be stockpiled in a separate working pile, as designated in the QC Plan, and only added to the sealed stockpile when test results for the working pile are complete and are found to meet tolerances specified herein for the original sealed FRAP stockpile. Stockpiles shall be sufficiently separated to prevent intermingling at the base. All stockpiles (including unprocessed RAP and FRAP) shall be identified by signs indicating the type as listed below (i.e. "Non-Quality, FRAP -#4 or Type 2 RAS", etc...).

- (1) Fractionated RAP (FRAP). FRAP shall consist of RAP from Class I, HMA (High and Low ESAL) or equivalent mixtures. The coarse aggregate in FRAP shall be crushed aggregate and may represent more than one aggregate type and/or quality, but shall be at least C quality. All FRAP shall be processed prior to testing and sized into fractions with the separation occurring on or between the #4 (4.75 mm) and 1/2 in. (12.5 mm) sieves. Agglomerations shall be minimized such that 100 percent of the RAP in the coarse fraction shall pass the maximum sieve size specified for the mix the FRAP will be used in.
- (2) Restricted FRAP (B quality) stockpiles shall consist of RAP from Class I, HMA (High ESAL), or HMA (High ESAL). If approved by the Engineer, the aggregate from a maximum 3.0 in. (75 mm) single combined pass of surface/binder milling will be classified as B quality. All millings from this application will be processed into FRAP as described previously.
- (3) Conglomerate. Conglomerate RAP stockpiles shall consist of RAP from Class I, HMA (High and Low ESAL) or equivalent mixtures. The coarse aggregate in this RAP shall be crushed aggregate and may represent more than one aggregate type and/or quality, but shall be at least C quality. This RAP may have an inconsistent gradation and/or asphalt binder content prior to processing. All conglomerate RAP shall be processed (FRAP) prior to

2018 STREET IMPROVEMENTS VILLAGE OF VILLA PARK

testing. Conglomerate RAP stockpiles shall not contain steel slag or other expansive material as determined by the Department.

- (4) Conglomerate “D” Quality (DQ). Conglomerate DQ RAP stockpiles shall consist of RAP from HMA shoulders, bituminous stabilized subbases or HMA (Low ESAL)/HMA (Low ESAL) IL-19.0L binder mixture. The coarse aggregate in this RAP may be crushed or round but shall be at least D quality. This RAP may have an inconsistent gradation and/or asphalt binder content. Conglomerate DQ RAP stockpiles shall not contain steel slag or other expansive material as determined by the Department.
- (5) Non-Quality. RAP stockpiles that do not meet the requirements of the stockpile categories listed above shall be classified as “Non-Quality”.

RAP or FRAP containing contaminants, such as earth, brick, sand, concrete, sheet asphalt, bituminous surface treatment (i.e. chip seal), pavement fabric, joint sealants, plant cleanout etc., will be unacceptable unless the contaminants are removed to the satisfaction of the Engineer. Sheet asphalt shall be stockpiled separately.

- (b) RAS Stockpiles. Type 1 and Type 2 RAS shall be stockpiled separately and shall be sufficiently separated to prevent intermingling at the base. Each stockpile shall be signed indicating what type of RAS is present.

However, a RAS source may submit a written request to the Department for approval to blend mechanically a specified ratio of Type 1 RAS with Type 2 RAS. The source will not be permitted to change the ratio of the blend without the Department prior written approval. The Engineer’s written approval will be required, to mechanically blend RAS with any fine aggregate produced under the AGCS, up to an equal weight of RAS, to improve workability. The fine aggregate shall be “B Quality” or better from an approved Aggregate Gradation Control System source. The fine aggregate shall be one that is approved for use in the HMA mixture and accounted for in the mix design and during HMA production.

Records identifying the shingle processing facility supplying the RAS, RAS type, and lot number shall be maintained by project contract number and kept for a minimum of three years.

1031.03 Testing. FRAP and RAS testing shall be according to the following.

- (a) FRAP Testing. When used in HMA, the FRAP shall be sampled and tested either during processing or after stockpiling. It shall also be sampled during HMA production.

**2018 STREET IMPROVEMENTS
VILLAGE OF VILLA PARK**

- (1) During Stockpiling. For testing during stockpiling, washed extraction samples shall be run at the minimum frequency of one sample per 500 tons (450 metric tons) for the first 2000 tons (1800 metric tons) and one sample per 2000 tons (1800 metric tons) thereafter. A minimum of five tests shall be required for stockpiles less than 4000 tons (3600 metric tons).
- (2) Incoming Material. For testing as incoming material, washed extraction samples shall be run at a minimum frequency of one sample per 2000 tons (1800 metric tons) or once per week, whichever comes first.
- (3) After Stockpiling. For testing after stockpiling, the Contractor shall submit a plan for approval to the District proposing a satisfactory method of sampling and testing the RAP/FRAP pile either in-situ or by restockpiling. The sampling plan shall meet the minimum frequency required above and detail the procedure used to obtain representative samples throughout the pile for testing.

Before extraction, each field sample of FRAP, shall be split to obtain two samples of test sample size. One of the two test samples from the final split shall be labeled and stored for Department use. The Contractor shall extract the other test sample according to Department procedure. The Engineer reserves the right to test any sample (split or Department-taken) to verify Contractor test results.

- (b) RAS Testing. RAS shall be sampled and tested during stockpiling according to Central Bureau of Materials Policy Memorandum, "Reclaimed Asphalt Shingle (RAS) Sources". The Contractor shall also sample as incoming material at the HMA plant.

- (1) During Stockpiling. Washed extraction and testing for unacceptable materials shall be run at the minimum frequency of one sample per 200 tons (180 metric tons) for the first 1000 tons (900 metric tons) and one sample per 1000 tons (900 metric tons) thereafter. A minimum of five samples are required for stockpiles less than 1000 tons (900 metric tons). Once a ≤ 1000 ton (900 metric ton), five-sample/test stockpile has been established it shall be sealed. Additional incoming RAS shall be in a separate working pile as designated in the Quality Control plan and only added to the sealed stockpile when the test results of the working pile are complete and are found to meet the tolerances specified herein for the original sealed RAS stockpile.

- (2) Incoming Material. For testing as incoming material at the HMA plant, washed extraction shall be run at the minimum frequency of one sample per 250 tons (227 metric tons). A minimum of five samples are required for stockpiles less than 1000 tons (900 metric tons). The incoming material test results shall meet the tolerances specified herein.

**2018 STREET IMPROVEMENTS
VILLAGE OF VILLA PARK**

The Contractor shall obtain and make available all test results from start of the initial stockpile sampled and tested at the shingle processing facility in accordance with the facility's QC Plan.

Before extraction, each field sample shall be split to obtain two samples of test sample size. One of the two test samples from the final split shall be labeled and stored for Department use. The Contractor shall extract the other test sample according to Department procedures. The Engineer reserves the right to test any sample (split or Department-taken) to verify Contractor test results.

1031.04 Evaluation of Tests. Evaluation of test results shall be according to the following.

- (a) Evaluation of FRAP Test Results. All test results shall be compiled to include asphalt binder content, gradation and, when applicable (for slag), G_{mm} . A five test average of results from the original pile will be used in the mix designs. Individual extraction test results run thereafter, shall be compared to the average used for the mix design, and will be accepted if within the tolerances listed below.

Parameter	FRAP
No. 4 (4.75 mm)	± 6 %
No. 8 (2.36 mm)	± 5 %
No. 30 (600 μ m)	± 5 %
No. 200 (75 μ m)	± 2.0 %
Asphalt Binder	± 0.3 %
G_{mm}	± 0.03 ^{1/}

- 1/ For stockpile with slag or steel slag present as determined in the current Manual of Test Procedures Appendix B 21, "Determination of Reclaimed Asphalt Pavement Aggregate Bulk Specific Gravity".

If any individual sieve and/or asphalt binder content tests are out of the above tolerances when compared to the average used for the mix design, the FRAP stockpile shall not be used in Hot-Mix Asphalt unless the FRAP representing those tests is removed from the stockpile. All test data and acceptance ranges shall be sent to the District for evaluation.

The Contractor shall maintain a representative moving average of five tests to be used for Hot-Mix Asphalt production.

With the approval of the Engineer, the ignition oven may be substituted for extractions according to the ITP, "Calibration of the Ignition Oven for the Purpose of Characterizing Reclaimed Asphalt Pavement (RAP)" or Illinois Modified AASHTO T-164-11, Test Method A.

**2018 STREET IMPROVEMENTS
VILLAGE OF VILLA PARK**

(b) Evaluation of RAS Test Results. All of the test results, with the exception of percent unacceptable materials, shall be compiled and averaged for asphalt binder content and gradation. A five test average of results from the original pile will be used in the mix designs. Individual test results run thereafter, when compared to the average used for the mix design, will be accepted if within the tolerances listed below.

Parameter	RAS
No. 8 (2.36 mm)	± 5 %
No. 16 (1.18 mm)	± 5 %
No. 30 (600 µm)	± 4 %
No. 200 (75 µm)	± 2.5 %
Asphalt Binder Content	± 2.0 %

If any individual sieve and/or asphalt binder content tests are out of the above tolerances when compared to the average used for the mix design, the RAS shall not be used in Hot-Mix Asphalt unless the RAS representing those tests is removed from the stockpile. All test data and acceptance ranges shall be sent to the District for evaluation.

(c) Quality Assurance by the Engineer. The Engineer may witness the sampling and splitting conduct assurance tests on split samples taken by the Contractor for quality control testing a minimum of once a month.

The overall testing frequency will be performed over the entire range of Contractor samples for asphalt binder content and gradation. The Engineer may select any or all split samples for assurance testing. The test results will be made available to the Contractor as soon as they become available.

The Engineer will notify the Contractor of observed deficiencies.

Differences between the Contractor's and the Engineer's split sample test results will be considered acceptable if within the following limits.

Test Parameter	Acceptable Limits of Precision	
	FRAP	RAS
% Passing: ^{1/}		
1/2 in.	5.0%	
No. 4	5.0%	
No. 8	3.0%	4.0%
No. 30	2.0%	4.0%
No. 200	2.2%	4.0%
Asphalt Binder Content	0.3%	3.0%

**2018 STREET IMPROVEMENTS
VILLAGE OF VILLA PARK**

G_{mm}	0.030	
----------	-------	--

1/ Based on washed extraction.

In the event comparisons are outside the above acceptable limits of precision, the Engineer will immediately investigate.

(d) Acceptance by the Engineer. Acceptable of the material will be based on the validation of the Contractor's quality control by the assurance process.

1031.05 Quality Designation of Aggregate in RAP and FRAP.

(a) RAP. The aggregate quality of the RAP for homogeneous, conglomerate, and conglomerate "D" quality stockpiles shall be set by the lowest quality of coarse aggregate in the RAP stockpile and are designated as follows.

(1) RAP from Class I, HMA (High ESAL), or (Low ESAL) IL-9.5L surface mixtures are designated as containing Class B quality coarse aggregate.

(2) RAP from HMA (Low ESAL) IL-19.0L binder mixture is designated as Class D quality coarse aggregate.

(3) RAP from Class I, HMA (High ESAL) binder mixtures, bituminous base course mixtures, and bituminous base course widening mixtures are designated as containing Class C quality coarse aggregate.

(4) RAP from bituminous stabilized subbase and BAM shoulders are designated as containing Class D quality coarse aggregate.

(b) FRAP. If the Engineer has documentation of the quality of the FRAP aggregate, the Contractor shall use the assigned quality provided by the Engineer.

If the quality is not known, the quality shall be determined as follows. Fractionated RAP stockpiles containing plus #4 (4.75 mm) sieve coarse aggregate shall have a maximum tonnage of 5,000 tons (4,500 metric tons). The Contractor shall obtain a representative sample witnessed by the Engineer. The sample shall be a minimum of 50 lb (25 kg). The sample shall be extracted according to Illinois Modified AASHTO T 164 by a consultant laboratory prequalified by the Department for the specified testing. The consultant laboratory shall submit the test results along with the recovered aggregate to the District Office. The cost for this testing shall be paid by the Contractor. The District will forward the sample to the Central Bureau of Materials Aggregate Lab for MicroDeval Testing, according to ITP 327. A maximum loss of 15.0 percent will be applied for all HMA applications. The fine aggregate portion of the fractionated RAP shall not be used in any HMA mixtures that require a minimum

**2018 STREET IMPROVEMENTS
VILLAGE OF VILLA PARK**

of "B" quality aggregate or better, until the coarse aggregate fraction has been determined to be acceptable thru a MicroDeval Testing.

1031.06 Use of FRAP and/or RAS in HMA. The use of FRAP and/or RAS shall be the Contractor's option when constructing HMA in all contracts.

(a) FRAP. The use of FRAP in HMA shall be as follows.

- (1) Coarse Aggregate Size (after extraction). The coarse aggregate in all FRAP shall be equal to or less than the nominal maximum size requirement for the HMA mixture to be produced.
- (2) Steel Slag Stockpiles. FRAP stockpiles containing steel slag or other expansive material, as determined by the Department, shall be homogeneous and will be approved for use in HMA (High ESAL and Low ESAL) mixtures regardless of lift or mix type.
- (3) Use in HMA Surface Mixtures (High and Low ESAL). FRAP stockpiles for use in HMA surface mixtures (High and Low ESAL) shall have coarse aggregate that is Class B quality or better. FRAP shall be considered equivalent to limestone for frictional considerations unless produced/screened to minus 3/8 inch.
- (4) Use in HMA Binder Mixtures (High and Low ESAL), HMA Base Course, and HMA Base Course Widening. FRAP stockpiles for use in HMA binder mixtures (High and Low ESAL), HMA base course, and HMA base course widening shall be FRAP in which the coarse aggregate is Class C quality or better.
- (5) Use in Shoulders and Subbase. FRAP stockpiles for use in HMA shoulders and stabilized subbase (HMA) shall be FRAP, Restricted FRAP, conglomerate, or conglomerate DQ.

(b) RAS. RAS meeting Type 1 or Type 2 requirements will be permitted in all HMA applications as specified herein.

(c) FRAP and/or RAS Usage Limits. Type 1 or Type 2 RAS may be used alone or in conjunction with FRAP in HMA mixtures up to a maximum of 5.0 percent by weight of the total mix.

When FRAP is used alone or FRAP is used in conjunction with RAS, the percent of virgin asphalt binder replacement (ABR) shall not exceed the amounts indicated in the table below for a given N Design.

Max Asphalt Binder Replacement for FRAP with RAS Combination

**2018 STREET IMPROVEMENTS
VILLAGE OF VILLA PARK**

HMA Mixtures ^{1/2/} _{4/}	Maximum % ABR		
	Ndesign	Binder/Leveling Binder	Surface
30L	50	40	30
50	40	35	30
70	40	30	30
90	40	30	30
4.75 mm N-50			40
SMA N-80			30

- 1/ For Low ESAL HMA shoulder and stabilized subbase, the percent asphalt binder replacement shall not exceed 50 % of the total asphalt binder in the mixture.
- 2/ When the binder replacement exceeds 15 % for all mixes, except for SMA and IL-4.75, the high and low virgin asphalt binder grades shall each be reduced by one grade (i.e. 25 % binder replacement using a virgin asphalt binder grade of PG64-22 will be reduced to a PG58-28). When constructing full depth HMA and the ABR is less than 15 %, the required virgin asphalt binder grade shall be PG64-28.
- 3/ When the ABR for SMA or IL-4.75 is 15 % or less, the required virgin asphalt binder shall be SBS PG76-22 and the elastic recovery shall be a minimum of 80. When the ABR for SMA or IL-4.75 exceeds 15%, the virgin asphalt binder grade shall be SBS PG70-28 and the elastic recovery shall be a minimum of 80.
- 4/ When FRAP or RAS is used alone, the maximum percent asphalt binder replacement designated on the table shall be reduced by 10 %.

1031.07 HMA Mix Designs. At the Contractor's option, HMA mixtures may be constructed utilizing RAP/FRAP and/or RAS material meeting the detailed requirements specified herein.

- (a) FRAP and/or RAS. FRAP and /or RAS mix designs shall be submitted for verification. If additional FRAP or RAS stockpiles are tested and found to be within tolerance, as defined under "Evaluation of Tests" herein, and meet all requirements herein, the additional FRAP or RAS stockpiles may be used in the original design at the percent previously verified.

(b) RAS. Type 1 and Type 2 RAS are not interchangeable in a mix design.

The RAP, FRAP and RAS stone specific gravities (G_{sb}) shall be according to the "Determination of Aggregate Bulk (Dry) Specific Gravity (G_{sb}) or Reclaimed Asphalt Pavement (RAP) and Reclaimed Asphalt Shingles (RAS)" procedure in the Department's Manual of Test Procedures for Materials.

1031.08 HMA Production. HMA production utilizing FRAP and/or RAS shall be as follows.

To remove or reduce agglomerated material, a scalping screen, gator, crushing unit, or comparable sizing device approved by the Engineer shall be used in the RAS and FRAP feed system to remove or reduce oversized material.

If during mix production, corrective actions fail to maintain FRAP, RAS or QC/QA test results within control tolerances or the requirements listed herein the Contractor shall cease production of the mixture containing FRAP or RAS and conduct an investigation that may require a new mix design.

(a) RAS. RAS shall be incorporated into the HMA mixture either by a separate weight depletion system or by using the RAP weigh belt. Either feed system shall be interlocked with the aggregate feed or weigh system to maintain correct proportions for all rates of production and batch sizes. The portion of RAS shall be controlled accurately to within ± 0.5 percent of the amount of RAS utilized. When using the weight depletion system, flow indicators or sensing devices shall be provided and interlocked with the plant controls such that the mixture production is halted when RAS flow is interrupted.

(b) HMA Plant Requirements. HMA plants utilizing FRAP and/or RAS shall be capable of automatically recording and printing the following information.

(1) Dryer Drum Plants.

- a. Date, month, year, and time to the nearest minute for each print.
- b. HMA mix number assigned by the Department.
- c. Accumulated weight of dry aggregate (combined or individual) in tons (metric tons) to the nearest 0.1 ton (0.1 metric ton).
- d. Accumulated dry weight of RAS and FRAP in tons (metric tons) to the nearest 0.1 ton (0.1 metric ton).

**2018 STREET IMPROVEMENTS
VILLAGE OF VILLA PARK**

- e. Accumulated mineral filler in revolutions, tons (metric tons), etc. to the nearest 0.1 unit.
 - f. Accumulated asphalt binder in gallons (liters), tons (metric tons), etc. to the nearest 0.1 unit.
 - g. Residual asphalt binder in the RAS and FRAP material as a percent of the total mix to the nearest 0.1 percent.
 - h. Aggregate RAS and FRAP moisture compensators in percent as set on the control panel. (Required when accumulated or individual aggregate and RAS and FRAP are printed in wet condition.)
 - i. When producing mixtures with FRAP and/or RAS, a positive dust control system shall be utilized.
 - j. Accumulated mixture tonnage.
 - k. Dust Removed (accumulated to the nearest 0.1 ton (0.1 metric ton))
- (2) Batch Plants.
- a. Date, month, year, and time to the nearest minute for each print.
 - b. HMA mix number assigned by the Department.
 - c. Individual virgin aggregate hot bin batch weights to the nearest pound (kilogram).
 - d. Mineral filler weight to the nearest pound (kilogram).
 - f. RAS and FRAP weight to the nearest pound (kilogram).
 - g. Virgin asphalt binder weight to the nearest pound (kilogram).
 - h. Residual asphalt binder in the RAS and FRAP material as a percent of the total mix to the nearest 0.1 percent.

The printouts shall be maintained in a file at the plant for a minimum of one year or as directed by the Engineer and shall be made available upon request. The printing system will be inspected by the Engineer prior to production and verified at the beginning of each construction season thereafter.

1031.09 RAP in Aggregate Surface Course and Aggregate Wedge Shoulders, Type B. The use of RAP or FRAP in aggregate surface course and aggregate shoulders shall be as follows.

- (a) Stockpiles and Testing. RAP stockpiles may be any of those listed in Article 1031.02, except “Non-Quality” and “FRAP”. The testing requirements of Article 1031.03 shall not apply. RAP used shall be according to the current Central Bureau of Materials Policy Memorandum, “Reclaimed Asphalt Pavement (RAP) for Aggregate Applications”.
- (b) Gradation. The RAP material shall meet the gradation requirements for CA 6 according to Article 1004.01(c), except the requirements for the minus No. 200 (75 µm) sieve shall not apply. The sample for the RAP material shall be air dried to constant weight prior to being tested for gradation.”

NOT FOR BIDD

BDE SPECIAL PROVISIONS
For the August 3 and September 21, 2018 Lettings

The following special provisions indicated by an "x" are applicable to this contract and will be included by the Project Development and Implementation Section of the BD&E. An * indicates a new or revised special provision for the letting.

<u>File Name</u>	<u>#</u>	<u>Special Provision Title</u>	<u>Effective</u>	<u>Revised</u>
80099	1	Accessible Pedestrian Signals (APS)	April 1, 2003	Jan. 1, 2014
80382	2	Adjusting Frames and Grates	April 1, 2017	
80274	3	Aggregate Subgrade Improvement	April 1, 2012	April 1, 2016
80192	4	Automated Flagger Assistance Device	Jan. 1, 2008	
80173	5	Bituminous Materials Cost Adjustments	Nov. 2, 2006	Aug. 1, 2017
80241	6	Bridge Demolition Debris	July 1, 2009	
5026I	7	Building Removal-Case I (Non-Friable and Friable Asbestos)	Sept. 1, 1990	April 1, 2010
5048I	8	Building Removal-Case II (Non-Friable Asbestos)	Sept. 1, 1990	April 1, 2010
5049I	9	Building Removal-Case III (Friable Asbestos)	Sept. 1, 1990	April 1, 2010
5053I	10	Building Removal-Case IV (No Asbestos)	Sept. 1, 1990	April 1, 2010
80366	11	Butt Joints	July 1, 2016	
80386	12	Calcium Aluminate Cement for Class PP-5 Concrete Patching	Nov. 1, 2017	
80396	13	Class A and B Patching	Jan. 1, 2018	
80384	14	Compensable Delay Costs	June 2, 2017	
80198	15	Completion Date (via calendar days)	April 1, 2008	
80199	16	Completion Date (via calendar days) Plus Working Days	April 1, 2008	
80293	17	Concrete Box Culverts with Skews > 30 Degrees and Design Fills ≤ 5 Feet	April 1, 2012	July 1, 2016
80311	18	Concrete End Sections for Pipe Culverts	Jan. 1, 2013	April 1, 2016
80277	19	Concrete Mix Design – Department Provided	Jan. 1, 2012	April 1, 2016
80261	20	Construction Air Quality – Diesel Retrofit	June 1, 2010	Nov. 1, 2014
80387	21	Contrast Preformed Plastic Pavement Marking	Nov. 1, 2017	
* 80029	22	Disadvantaged Business Enterprise Participation	Sept. 1, 2000	April 2, 2018
80378	23	Dowel Bar Inserter	Jan. 1, 2017	Jan. 1, 2018
80388	24	Equipment Parking and Storage	Nov. 1, 2017	
80229	25	Fuel Cost Adjustment	April 1, 2009	Aug. 1, 2017
80304	26	Grooving for Recessed Pavement Markings	Nov. 1, 2012	Nov. 1, 2017
* 80246	27	Hot-Mix Asphalt – Density Testing of Longitudinal Joints	Jan. 1, 2010	Aug. 1, 2018
* 80398	28	Hot-Mix Asphalt – Longitudinal Joint Sealant	Aug. 1, 2018	
* 80399	29	Hot-Mix Asphalt – Oscillatory Roller	Aug. 1, 2018	
* 80347	30	Hot-Mix Asphalt – Pay for Performance Using Percent Within Limits – Jobsite Sampling	Nov. 1, 2014	Aug. 1, 2018
80383	31	Hot-Mix Asphalt – Quality Control for Performance	April 1, 2017	Nov. 1, 2017
80376	32	Hot-Mix Asphalt – Tack Coat	Nov. 1, 2016	
80392	33	Lights on Barricades	Jan. 1, 2018	
80336	34	Longitudinal Joint and Crack Patching	April 1, 2014	April 1, 2016
* 80393	35	Manholes, Valve Vaults, and Flat Slab Tops	Jan. 1, 2018	March 2, 2018
* 80400	36	Mast Arm Assembly and Pole	Aug. 1, 2018	
80045	37	Material Transfer Device	June 15, 1999	Aug. 1, 2014
80394	38	Metal Flared End Section for Pipe Culverts	Jan. 1, 2018	April 1, 2018
80165	39	Moisture Cured Urethane Paint System	Nov. 1, 2006	Jan. 1, 2010
80349	40	Pavement Marking Blackout Tape	Nov. 1, 2014	April 1, 2016
80371	41	Pavement Marking Removal	July 1, 2016	
80390	42	Payments to Subcontractors	Nov. 2, 2017	
80377	43	Portable Changeable Message Signs	Nov. 1, 2016	April 1, 2017
80389	44	Portland Cement Concrete	Nov. 1, 2017	
80359	45	Portland Cement Concrete Bridge Deck Curing	April 1, 2015	Nov. 1, 2017
* 80401	46	Portland Cement Concrete Pavement Connector for Bridge Approach	Aug. 1, 2018	

File Name	#	Special Provision Title	Effective	Revised
		Slab		
80385	47	Portland Cement Concrete Sidewalk	Aug. 1, 2017	
80300	48	Preformed Plastic Pavement Marking Type D - Inlaid	April 1, 2012	April 1, 2016
80328	49	Progress Payments	Nov. 2, 2013	
3426I	50	Railroad Protective Liability Insurance	Dec. 1, 1986	Jan. 1, 2006
80157	51	Railroad Protective Liability Insurance (5 and 10)	Jan. 1, 2006	
80306	52	Reclaimed Asphalt Pavement (RAP) and Reclaimed Asphalt Shingles (RAS)	Nov. 1, 2012	Jan. 1, 2018
80395	53	Sloped Metal End Section for Pipe Culverts	Jan. 1, 2018	
80340	54	Speed Display Trailer	April 2, 2014	Jan. 1, 2017
80127	55	Steel Cost Adjustment	April 2, 2004	Aug. 1, 2017
* 80397	56	Subcontractor and DBE Payment Reporting	April 2, 2018	
80391	57	Subcontractor Mobilization Payments	Nov. 2, 2017	
80317	58	Surface Testing of Hot-Mix Asphalt Overlays	Jan. 1, 2013	April 1, 2016
80298	59	Temporary Pavement Marking (NOTE: This special provision was previously named "Pavement Marking Tape Type IV".)	April 1, 2012	April 1, 2017
20338	60	Training Special Provisions	Oct. 15, 1975	
80318	61	Traversable Pipe Grate for Concrete End Sections (NOTE: This special provision was previously named "Traversable Pipe Grate".)	Jan. 1, 2013	Jan. 1, 2018
80288	62	Warm Mix Asphalt	Jan. 1, 2012	April 1, 2016
80302	63	Weekly DBE Trucking Reports	June 2, 2012	April 2, 2015
80071	64	Working Days	Jan. 1, 2002	

The following special provisions are in the 2018 Supplemental Specifications and Recurring Special Provisions.

File Name	Special Provision Title	New Location	Effective	Revised
80368	Light Tower	Article 1069.08	July 1, 2016	
80369	Mast Arm Assembly and Pole	Article 1077.03(a)(1)	July 1, 2016	
80338	Portland Cement Concrete Partial Depth Hot-Mix Asphalt Patching	Recurring CS #35	April 1, 2014	April 1, 2016
80379	Steel Plate Beam Guardrail	Articles 630.02, 630.05, 630.06, and 630.08	Jan. 1, 2017	
80381	Traffic Barrier Terminal, Type 1 Special	Article 631.04	Jan. 1, 2017	
80380	Tubular Markers	Articles 701.03, 701.15, 701.18, and 1106.02	Jan. 1, 2017	

The following special provisions require additional information from the designer. The additional information needs to be submitted as a separate document. The Project Development and Implementation section will then include the information in the applicable special provision. The Special Provisions are:

- Bridge Demolition Debris
- Building Removal - Case I
- Building Removal - Case II
- Building Removal - Case III
- Building Removal-Case IV
- Completion Date
- Completion Date Plus Working Days
- DBE Participation
- Material Transfer Device
- Railroad Protective Liability Insurance
- Training Special Provisions
- Working Days

COMPLETION DATE (VIA CALENDAR DAYS) (BDE)

Effective: April 1, 2008

The Contractor shall complete all work on or before the completion date of this contract which will be based upon 60 calendar days.

The completion date will be determined by adding the specified number of calendar days to the date the Contractor begins work, or to the date ten days after execution of the contract, whichever is the earlier, unless a delayed start is granted by the Engineer.

80198

NOT FOR BIDD

CONSTRUCTION AIR QUALITY – DIESEL RETROFIT (BDE)

Effective: June 1, 2010

Revised: November 1, 2014

The reduction of emissions of particulate matter (PM) for off-road equipment shall be accomplished by installing retrofit emission control devices. The term “equipment” refers to diesel fuel powered devices rated at 50 hp and above, to be used on the jobsite in excess of seven calendar days over the course of the construction period on the jobsite (including rental equipment).

Contractor and subcontractor diesel powered off-road equipment assigned to the contract shall be retrofitted using the phased in approach shown below. Equipment that is of a model year older than the year given for that equipment’s respective horsepower range shall be retrofitted:

Effective Dates	Horsepower Range	Model Year
June 1, 2010 ^{1/}	600-749	2002
	750 and up	2006
June 1, 2011 ^{2/}	100-299	2003
	300-599	2001
	600-749	2002
	750 and up	2006
June 1, 2012 ^{2/}	50-99	2004
	100-299	2003
	300-599	2001
	600-749	2002
	750 and up	2006

1/ Effective dates apply to Contractor diesel powered off-road equipment assigned to the contract.

2/ Effective dates apply to Contractor and subcontractor diesel powered off-road equipment assigned to the contract.

The retrofit emission control devices shall achieve a minimum PM emission reduction of 50 percent and shall be:

- a) Included on the U.S. Environmental Protection Agency (USEPA) *Verified Retrofit Technology List* (<http://www.epa.gov/cleandiesel/verification/verif-list.htm>), or verified by the California Air Resources Board (CARB) (<http://www.arb.ca.gov/diesel/verdev/vt/cvt.htm>); or
- b) Retrofitted with a non-verified diesel retrofit emission control device if verified retrofit emission control devices are not available for equipment proposed to be used on the project, and if the Contractor has obtained a performance certification from the retrofit

device manufacturer that the emission control device provides a minimum PM emission reduction of 50 percent.

Note: Large cranes (Crawler mounted cranes) which are responsible for critical lift operations are exempt from installing retrofit emission control devices if such devices adversely affect equipment operation.

Diesel powered off-road equipment with engine ratings of 50 hp and above, which are unable to be retrofitted with verified emission control devices or if performance certifications are not available which will achieve a minimum 50 percent PM reduction, may be granted a waiver by the Department if documentation is provided showing good faith efforts were made by the Contractor to retrofit the equipment.

Construction shall not proceed until the Contractor submits a certified list of the diesel powered off-road equipment that will be used, and as necessary, retrofitted with emission control devices. The list(s) shall include (1) the equipment number, type, make, Contractor/rental company name; and (2) the emission control devices make, model, USEPA or CARB verification number, or performance certification from the retrofit device manufacturer. Equipment reported as fitted with emissions control devices shall be made available to the Engineer for visual inspection of the device installation, prior to being used on the jobsite.

The Contractor shall submit an updated list of retrofitted off-road construction equipment as retrofitted equipment changes or comes on to the jobsite. The addition or deletion of any diesel powered equipment shall be included on the updated list.

If any diesel powered off-road equipment is found to be in non-compliance with any portion of this special provision, the Engineer will issue the Contractor a diesel retrofit deficiency deduction.

Any costs associated with retrofitting any diesel powered off-road equipment with emission control devices shall be considered as included in the contract unit prices bid for the various items of work involved and no additional compensation will be allowed. The Contractor's compliance with this notice and any associated regulations shall not be grounds for a claim.

Diesel Retrofit Deficiency Deduction

When the Engineer determines that a diesel retrofit deficiency exists, a daily monetary deduction will be imposed for each calendar day or fraction thereof the deficiency continues to exist. The calendar day(s) will begin when the time period for correction is exceeded and end with the Engineer's written acceptance of the correction. The daily monetary deduction will be \$1,000.00 for each deficiency identified.

The deficiency will be based on lack of diesel retrofit emissions control.

If a Contractor accumulates three diesel retrofit deficiency deductions for the same piece of equipment in a contract period, the Contractor will be shutdown until the deficiency is corrected.

Such a shutdown will not be grounds for any extension of the contract time, waiver of penalties, or be grounds for any claim.

80261

NOT FOR BID

HOT-MIX ASPHALT - DENSITY TESTING OF LONGITUDINAL JOINTS (BDE)

Effective: January 1, 2010

Revised: August 1, 2018

Description. This work shall consist of testing the density of longitudinal joints as part of the quality control/quality assurance (QC/QA) of hot-mix asphalt (HMA). Work shall be according to Section 1030 of the Standard Specifications except as follows.

Quality Control/Quality Assurance (QC/QA). Delete the second and third sentence of the third paragraph of Article 1030.05(d)(3) of the Standard Specifications.

Add the following paragraphs to the end of Article 1030.05(d)(3) of the Standard Specifications:

“Longitudinal joint density testing shall be performed at each random density test location. Longitudinal joint testing shall be located at a distance equal to the lift thickness or a minimum of 4 in. (100 mm), from each pavement edge. (i.e. for a 5 in. (125 mm) lift the near edge of the density gauge or core barrel shall be within 5 in. (125 mm) from the edge of pavement.) Longitudinal joint density testing shall be performed using either a correlated nuclear gauge or cores.

- a. Confined Edge. Each confined edge density shall be represented by a one-minute nuclear density reading or a core density and shall be included in the average of density readings or core densities taken across the mat which represents the Individual Test.
- b. Unconfined Edge. Each unconfined edge joint density shall be represented by an average of three one-minute density readings or a single core density at the given density test location and shall meet the density requirements specified herein. The three one-minute readings shall be spaced 10 ft (3 m) apart longitudinally along the unconfined pavement edge and centered at the random density test location.

When a longitudinal joint sealant (LJS) is applied, longitudinal joint density testing will not be required on the joint(s) sealed.”

Revise the Density Control Limits table in Article 1030.05(d)(4) of the Standard Specifications to read:

“Mixture Composition	Parameter	Individual Test (includes confined edges)	Unconfined Edge Joint Density Minimum
IL-4.75	Ndesign = 50	93.0 – 97.4% ^{1/}	91.0%
IL-9.5	Ndesign = 90	92.0 – 96.0%	90.0%
IL-9.5,IL-9.5L	Ndesign < 90	92.5 – 97.4%	90.0%
IL-19.0	Ndesign = 90	93.0 – 96.0%	90.0%
IL-19.0, IL-19.0L	Ndesign < 90	93.0 ^{2/} – 97.4%	90.0%

SMA	Ndesign = 50 & 80	93.5 – 97.4%	91.0%
-----	-------------------	--------------	-------

80246

NOT FOR BID

HOT-MIX ASPHALT – TACK COAT (BDE)

Effective: November 1, 2016

Revise Article 1032.06(a) of the Standard Specifications to read:

“(a) Anionic Emulsified Asphalt. Anionic emulsified asphalts shall be according to AASHTO M 140. SS-1h emulsions used as a tack coat shall have the cement mixing test waived.”

80376

NOT FOR BID

LIGHTS ON BARRICADES (BDE)

Effective: January 1, 2018

Revise Article 701.16 of the Standard Specifications to read:

“701.16 Lights. Lights shall be used on devices as required in the plans, the traffic control plan, and the following table.

Circumstance	Lights Required
Daylight operations	None
First two warning signs on each approach to the work involving a nighttime lane closure and “ROUGH GROOVED SURFACE” (W8-I107) signs	Flashing mono-directional lights
Devices delineating isolated obstacles, excavations, or hazards at night (Does not apply to patching)	Flashing bi-directional lights
Devices delineating obstacles, excavations, or hazards exceeding 100 ft (30 m) in length at night (Does not apply to widening)	Steady burn bi-directional lights
Channelizing devices for nighttime lane closures on two-lane roads	None
Channelizing devices for nighttime lane closures on multi-lane roads	None
Channelizing devices for nighttime lane closures on multi-lane roads separating opposing directions of traffic	None
Channelizing devices for nighttime along lane shifts on multilane roads	Steady burn mono-directional lights
Channelizing devices for night time along lane shifts on two lane roads	Steady burn bi-directional lights
Devices in nighttime lane closure tapers on Standards 701316 and 701321	Steady burn bi-directional lights
Devices in nighttime lane closure tapers	Steady burn mono-directional lights
Devices delineating a widening trench	None
Devices delineating patches at night on roadways with an ADT less than 25,000	None
Devices delineating patches at night on roadways with an ADT of 25,000 or more	None

Batteries for the lights shall be replaced on a group basis at such times as may be specified by the Engineer.”

Delete the fourth sentence of the first paragraph of Article 701.17(c)(2) of the Standard Specifications.

Revise the first paragraph of Article 603.07 of the Standard Specifications to read:

“603.07 Protection Under Traffic. After the casting has been adjusted and Class SI concrete has been placed, the work shall be protected by a barricade for at least 72 hours.”

80392

NOT FOR BID

MANHOLES, VALVE VAULTS, AND FLAT SLAB TOPS (BDE)

Effective: January 1, 2018

Revised: March 2, 2018

Description. Manholes, valve vaults, and flat slab tops manufactured according to the current or previous Highway Standards listed below will be accepted on this contract:

<u>Product</u>	<u>Current Standard</u>	<u>Previous Standard</u>
Precast Manhole Type A, 4' (1.22 m) Diameter	602401-04	602401-03
Precast Manhole Type A, 5' (1.52 m) Diameter	602402	602401-03
Precast Manhole Type A, 6' (1.83 m) Diameter	602406-08	602406-07
Precast Manhole Type A, 7' (2.13 m) Diameter	602411-06	602411-05
Precast Manhole Type A, 8' (2.44 m) Diameter	602416-06	602416-05
Precast Manhole Type A, 9' (2.74 m) Diameter	602421-06	602421-05
Precast Manhole Type A, 10' (3.05 m) Diameter	602426	n/a
Precast Valve Vault Type A, 4' (1.22 m) Diameter	602501-03	602501-02
Precast Valve Vault Type A, 5' (1.52 m) Diameter	602506	602501-02
Precast Reinforced Concrete Flat Slab Top	602601-05	602601-04

When manufacturing to the current standards, the following revisions to the Standard Specifications shall apply:

Revise Article 602.02(g) of the Standard Specifications to read:

“(g) Structural Steel (Note 4).....1006.04

Note 4. All components of the manhole joint splice shall be galvanized according to the requirements of AASHTO M 111 or M 232 as applicable.”

Add the following to Article 602.02 of the Standard Specifications:

“(s) Anchor Bolts and Rods (Note 5).....1006.09

Note 5. The threaded rods for the manhole joint splice shall be according to the requirements of ASTM F 1554, Grade 55, (Grade 380).”

Add the following paragraph after the first paragraph of Article 602.07 of the Standard Specifications:

“Threaded rods connecting precast sections shall be brought to a snug tight condition.”

Revise the second paragraph of Article 1042.10 of the Standard Specifications to read:

“Catch basin Types A, B, C, and D; Manhole Type A; Inlet Types A and B; Drainage Structures Types 1, 2, 3, 4, 5, and 6; Valve Vault Type A; and reinforced concrete flat slab top

(Highway Standard 602601) shall be according to AASHTO M 199 (M 199M), except the minimum wall thickness shall be 3 in. (75 mm). Additionally, catch basins, inlets, and drainage structures shall have a minimum concrete compressive strength of 4500 psi (31,000 kPa) at 28 days and manholes, valve vaults, and reinforced concrete flat slab tops shall have a minimum concrete compressive strength of 5000 psi (34,500 kPa) at 28 days.”

80393

NOT FOR BIDDING

PORTLAND CEMENT CONCRETE (BDE)

Effective: November 1, 2017

Revise the Air Content % of Class PP Concrete in Table 1 Classes of Concrete and Mix Design Criteria in Article 1020.04 of the Standard Specifications to read:

Class of Conc.	Use	Air Content %
PP	Pavement Patching Bridge Deck Patching (10)	4.0 - 8.0"
	PP-1	
	PP-2	
	PP-3	
	PP-4	
	PP-5	

Revise Note (4) at the end of Table 1 Classes of Concrete and Mix Design Criteria in Article 1020.04 of the Standard Specifications to read:

"(4) For all classes of concrete, the maximum slump may be increased to 7 in (175 mm) when a high range water-reducing admixture is used. For Class SC, the maximum slump may be increased to 8 in. (200 mm). For Class PS, the maximum slump may be increased to 8 1/2 in. (215 mm) if the high range water-reducing admixture is the polycarboxylate type."

80389

PORTLAND CEMENT CONCRETE SIDEWALK (BDE)

Effective: August 1, 2017

Revise the first paragraph of Article 424.12 of the Standard Specifications to read:

“424.12 Method of Measurement. This work will be measured for payment in place and the area computed in square feet (square meters). Curb ramps, including side curbs and side flares, will be measured for payment as sidewalk. No deduction will be made for detectable warnings located within the ramp.”

80385

PROGRESS PAYMENTS (BDE)

Effective: November 2, 2013

Revise Article 109.07(a) of the Standard Specifications to read:

“(a) Progress Payments. At least once each month, the Engineer will make a written estimate of the quantity of work performed in accordance with the contract, and the value thereof at the contract unit prices. The amount of the estimate approved as due for payment will be vouchered by the Department and presented to the State Comptroller for payment. No amount less than \$1000.00 will be approved for payment other than the final payment.

Progress payments may be reduced by liens filed pursuant to Section 23(c) of the Mechanics' Lien Act, 770 ILCS 60/23(c).

If a Contractor or subcontractor has defaulted on a loan issued under the Department's Disadvantaged Business Revolving Loan Program (20 ILCS 2705/2705-610), progress payments may be reduced pursuant to the terms of that loan agreement. In such cases, the amount of the estimate related to the work performed by the Contractor or subcontractor, in default of the loan agreement, will be offset, in whole or in part, and vouchered by the Department to the Working Capital Revolving Fund or designated escrow account. Payment for the work shall be considered as issued and received by the Contractor or subcontractor on the date of the offset voucher. Further, the amount of the offset voucher shall be a credit against the Department's obligation to pay the Contractor, the Contractor's obligation to pay the subcontractor, and the Contractor's or subcontractor's total loan indebtedness to the Department. The offset shall continue until such time as the entire loan indebtedness is satisfied. The Department will notify the Contractor and Fund Control Agent in a timely manner of such offset. The Contractor or subcontractor shall not be entitled to additional payment in consideration of the offset.

The failure to perform any requirement, obligation, or term of the contract by the Contractor shall be reason for withholding any progress payments until the Department determines that compliance has been achieved.”

WARM MIX ASPHALT (BDE)

Effective: January 1, 2012

Revised: April 1, 2016

Description. This work shall consist of designing, producing and constructing Warm Mix Asphalt (WMA) in lieu of Hot Mix Asphalt (HMA) at the Contractor's option. Work shall be according to Sections 406, 407, 408, 1030, and 1102 of the Standard Specifications, except as modified herein. In addition, any references to HMA in the Standard Specifications, or the special provisions shall be construed to include WMA.

WMA is an asphalt mixture which can be produced at temperatures lower than allowed for HMA utilizing approved WMA technologies. WMA technologies are defined as the use of additives or processes which allow a reduction in the temperatures at which HMA mixes are produced and placed. WMA is produced by the use of additives, a water foaming process, or combination of both. Additives include minerals, chemicals or organics incorporated into the asphalt binder stream in a dedicated delivery system. The process of foaming injects water into the asphalt binder stream, just prior to incorporation of the asphalt binder with the aggregate.

Approved WMA technologies may also be used in HMA provided all the requirements specified herein, with the exception of temperature, are met. However, asphalt mixtures produced at temperatures in excess of 275 °F (135 °C) will not be considered WMA when determining the grade reduction of the virgin asphalt binder grade.

Equipment.

Revise the first paragraph of Article 1102.01 of the Standard Specifications to read:

"1102.01 Hot-Mix Asphalt Plant. The hot-mix asphalt (HMA) plant shall be the batch-type, continuous-type, or dryer drum plant. The plants shall be evaluated for prequalification rating and approval to produce HMA according to the current Bureau of Materials and Physical Research Policy Memorandum, "Approval of Hot-Mix Asphalt Plants and Equipment". Once approved, the Contractor shall notify the Bureau of Materials and Physical Research to obtain approval of all plant modifications. The plants shall not be used to produce mixtures concurrently for more than one project or for private work unless permission is granted in writing by the Engineer. The plant units shall be so designed, coordinated and operated that they will function properly and produce HMA having uniform temperatures and compositions within the tolerances specified. The plant units shall meet the following requirements."

Add the following to Article 1102.01(a) of the Standard Specifications.

"(11) Equipment for Warm Mix Technologies.

- a. Foaming. Metering equipment for foamed asphalt shall have an accuracy of ± 2 percent of the actual water metered. The foaming control system shall be electronically interfaced with the asphalt binder meter.

- b. Additives. Additives shall be introduced into the plant according to the supplier's recommendations and shall be approved by the Engineer. The system for introducing the WMA additive shall be interlocked with the aggregate feed or weigh system to maintain correct proportions for all rates of production and batch sizes."

Mix Design Verification.

Add the following to Article 1030.04 of the Standard Specifications.

"(e) Warm Mix Technologies.

- (1) Foaming. WMA mix design verification will not be required when foaming technology is used alone (without WMA additives). However, the foaming technology shall only be used on HMA designs previously approved by the Department.
- (2) Additives. WMA mix designs utilizing additives shall be submitted to the Engineer for mix design verification."

Construction Requirements.

Revise the second paragraph of Article 406.06(b)(1) of the Standard Specifications to read:

"The HMA shall be delivered at a temperature of 250 to 350 °F (120 to 175 °C). WMA shall be delivered at a minimum temperature of 215 °F (102 °C)."

Basis of Payment.

This work will be paid at the contract unit price bid for the HMA pay items involved. Anti-strip will not be paid for separately, but shall be considered as included in the cost of the work.

80288

State of Illinois
Department of Transportation
Bureau of Local Roads and Streets

SPECIAL PROVISION
FOR
BIDDING REQUIREMENTS AND CONDITIONS FOR CONTRACT PROPOSALS

Effective: January 1, 2001
Revised: January 2, 2012

All references to Sections or Articles in this specification shall be construed to mean specific Section or Article of the Standard Specifications for Road and Bridge Construction, adopted by the Department of Transportation.

Replace Article 102.01 of the Standard Specifications with the following:

“Prequalification of Bidders. When prequalification is required and the Awarding Authority for contract construction work is the County Board of a County, the Council, the City Council, or the President and Board of Trustees of a city, village, or town, each prospective bidder, in evidence of competence, shall furnish the Awarding Authority as a prerequisite to the release of proposal forms by the Awarding Authority, a certified or photostatic copy of a "Certificate of Eligibility" issued by the Department of Transportation, according to the Department's "Prequalification Manual".

The two low bidders must file, within 24 hours after the letting, a sworn affidavit in triplicate, showing all uncompleted contracts awarded to them and all low bids pending award for Federal, State, County, Municipal and private work, using the blank form made available for this affidavit. One copy shall be filed with the Awarding Authority and two copies with IDOT's District office.

Issuance of Proposal Forms. The Awarding Authority reserves the right to refuse to issue a proposal form for bidding purposes for any of the following reasons:

- (a) Lack of competency and adequate machinery, plant, and other equipment, as revealed by the financial statement and experience questionnaires required in the prequalification procedures.
- (b) Uncompleted work which, in the judgment of the Awarding Authority, might hinder or prevent the prompt completion of additional work awarded.
- (c) False information provided on a bidder's "Affidavit of Availability".
- (d) Failure to pay, or satisfactorily settle, all bills due for labor and material on former contracts in force at the time of issuance of proposal forms.
- (e) Failure to comply with any prequalification regulations of the Department.
- (f) Default under previous contracts.
- (g) Unsatisfactory performance record as shown by past work for the Awarding Authority, judged from the standpoint of workmanship and progress.
- (h) When the Contractor is suspended from eligibility to bid at a public letting where the contract is awarded by, or requires approval of, the Department.
- (i) When any agent, servant, or employee of the prospective bidder currently serves as a member, employee, or agent of a governmental body that is financially involved in the proposal work.

- (j) When any agent, servant, or employee of the perspective bidder has participated in the preparation of plans or specifications for the proposed work.

Interpretation of Quantities in the Bid Schedule. The quantities appearing in the bid schedule are approximate and are prepared for the comparison of bids. Payment to the Contractor will be made only for the actual quantities of work performed and accepted or materials furnished according to the contract. The scheduled quantities of work to be done and materials to be furnished may be increased, decreased, or omitted as hereinafter provided.

Examination of Plans, Specifications, Special Provisions, and Site of Work. The bidder shall, before submitting a bid, carefully examine the provisions of the contract. The bidder shall inspect in detail the site of the proposed work, investigate and become familiar with all the local conditions affecting the contract and fully acquaint themselves with the detailed requirements of construction. Submission of a bid shall be a conclusive assurance and warranty the bidder has made these examinations and the bidder understands all requirements for the performance of the work. If his/her bid is accepted, the bidder shall be responsible for all errors in the proposal resulting from his/her failure or neglect to comply with these instructions. The Awarding Authority will, in no case, be responsible for any costs, expenses, losses, or change in anticipated profits resulting from such failure or neglect of the bidder to make these examinations.

The bidder shall take no advantage of any error or omission in the proposal and advertised contract. Any prospective bidder, who desires an explanation or interpretation of the plans, specification, or any of the contract documents, shall request such in writing from the Awarding Authority, in sufficient time to allow a written reply by the Awarding Authority that can reach all prospective bidders before the submission of their bids. Any reply given a prospective bidder concerning any of the contract documents, plans, and specifications will be furnished to all prospective bidders in the form determined by the Awarding Authority including, but not limited to, an addendum, if the information is deemed by the Awarding Authority to be necessary in submitting bids or if the Awarding Authority concludes the information would aid competition. Oral explanations, interpretations, or instructions given before the submission of bids unless at a prebid conference will not be binding on the Awarding Authority.

Preparation of the Proposal. Bidders shall submit their proposals on the form furnished by the Awarding Authority. The proposal shall be executed properly, and bids shall be made for all items indicated in the proposal form, except when alternate bids are asked, a bid on more than one alternate for each item is not required, unless otherwise provided. The bidder shall indicate in figures, a unit price for each of the separate items called for in the proposal form; the bidder shall show the products of the respective quantities and unit prices in the column provided for that purpose, and the gross sum shown in the place indicated in the proposal form shall be the summation of said products. All writing shall be with ink or typewriter, except the signature of the bidder which shall be written in ink.

If the proposal is made by an individual, that individual's name and business address shall be shown. If made by a firm or partnership, the name and business address of each member of the firm or partnership shall be shown. If made by a corporation, the proposal shall show the names, titles, and business addresses of the president, corporate secretary and treasurer. The proposal shall be signed by president or someone with authority to execute contracts and attested by the corporate secretary or someone with authority to execute or attest to the execution of contracts.

When prequalification is required, the proposal form shall be submitted by an authorized bidder in the same name and style as shown on the "Contractor's Statement of Experience and Financial Condition" used for prequalification.

Rejection of Proposals. The Awarding Authority reserves the right to reject any proposal for any of the conditions in "Issuance of Proposal Forms" or for any of the following reasons:

- (a) More than one proposal for the same work from an individual, firm, partnership, or corporation under the same name or different names.
- (b) Evidence of collusion among bidders.
- (c) Unbalanced proposals in which the bid prices for some items are, in the judgment of the Awarding Authority, out of proportion to the bid prices for other items.
- (d) If the proposal does not contain a unit price for each pay item listed, except in the case of authorized alternate pay items or lump sum pay items.
- (e) If the proposal form is other than that furnished by the Awarding Authority; or if the form is altered or any part thereof is detached.
- (f) If there are omissions, erasures, alterations, unauthorized additions, conditional or alternate bids, or irregularities of any kind which may tend to make the proposal incomplete, indefinite or ambiguous as to its meaning.
- (g) If the bidder adds any provisions reserving the right to accept or reject an award, or to enter into a contract pursuant to an award.
- (h) If the proposal is not accompanied by the proper proposal guaranty.
- (i) If the proposal is prepared with other than ink or typewriter, or otherwise fails to meet the requirements of the above "Preparation of Proposal" section.

Proposal Guaranty. Each proposal shall be accompanied by a bid bond on the Department form contained in the proposal, executed by a corporate surety company satisfactory to the Awarding Authority, by a bank cashier's check or a properly certified check for not less than five percent of the amount bid, or for the amount specified in the following schedule:

Amount Bid		Proposal Guaranty
Up to	\$5,000	\$150
>\$5,000	\$10,000	\$300
>\$10,000	\$50,000	\$1,000
>\$50,000	\$100,000	\$3,000
>\$100,000	\$150,000	\$5,000
>\$150,000	\$250,000	\$7,500
>\$250,000	\$500,000	\$12,500
>\$500,000	\$1,000,000	\$25,000
>\$1,000,000	\$1,500,000	\$50,000
>\$1,500,000	\$2,000,000	\$75,000
>\$2,000,000	\$3,000,000	\$100,000
>\$3,000,000	\$5,000,000	\$150,000
>\$5,000,000	\$7,500,000	\$250,000
>\$7,500,000	\$10,000,000	\$400,000
>\$10,000,000	\$15,000,000	\$500,000
>\$15,000,000	\$20,000,000	\$600,000
>\$20,000,000	\$25,000,000	\$700,000
>\$25,000,000	\$30,000,000	\$800,000
>\$30,000,000	\$35,000,000	\$900,000
Over	\$35,000,000	\$1,000,000

In the event that one proposal guaranty check is intended to cover two or more proposals, the amount must equal to the sum of the proposal guaranties which would be required for each individual proposal.

Bank cashier's checks or properly certified checks accompanying proposals shall be made payable to the County Treasurer, when a County is the Awarding Authority; or the City, Village, or Town Treasurer, when a city, village, or town is the Awarding Authority.

The proposal guaranty checks of all, except the two lowest responsible, will be returned promptly after the proposals have been checked, tabulated, and the relation of the proposals established. Proposal guaranty checks of the two lowest bidders will be returned as soon as the contract and contract bond of the successful bidder have been properly executed and approved. Bid bonds will not be returned.

After a period of three working days has elapsed after the date of opening proposals, the Awarding Authority may permit the two lowest bidders to substitute for the bank cashier's checks or certified checks submitted with their proposals as proposal guaranties, bid bonds on the Department forms executed by corporate surety companies satisfactory to the Awarding Authority.

Delivery of Proposals. If a special envelope is supplied by the Awarding Authority, each proposal should be submitted in that envelope furnished by the Awarding Authority and the blank spaces on the envelope shall be filled in correctly to clearly indicate its contents. When an envelope other than the special one furnished by the Awarding Authority is used, it shall be marked to clearly indicate its contents. When sent by mail, the sealed proposal shall be addressed to the Awarding Authority at the address and in care of the official in whose office the bids are to be received. All proposals shall be filed prior to the time and at the place specified in the Notice to Bidders. Proposals received after the time specified will be returned to the bidder unopened.

Withdrawal of Proposals. Permission will be given a bidder to withdraw a proposal if the bidder makes the request in writing or in person before the time for opening proposals.

Public Opening of Proposals. Proposals will be opened and read publicly at the time and place specified in the Notice to Bidders. Bidders, their authorized agents, and other interested parties are invited to be present.

Consideration of Proposals. After the proposals are opened and read, they will be compared on the basis of the summation of the products of the quantities shown in the bid schedule by the unit bid prices. In awarding contracts, the Awarding Authority will, in addition to considering the amounts stated in the proposals, take into consideration the responsibility of the various bidders as determined from a study of the data required under "Prequalification of Bidders", and from other investigations which it may elect to make.

The right is reserved to reject any or all proposals, to waive technicalities, or to advertise for new proposals, if in the judgment of the Awarding Authority, the best interests of the Awarding Authority will be promoted thereby.

Award of Contract. The award of contract will be made within 45 calendar days after the opening of proposals to the lowest responsible and qualified bidder whose proposal complies with all the requirements prescribed. The successful bidder will be notified by letter of intent that his/her bid has been accepted, and subject to the following conditions, the bidder will be the Contractor.

An approved contract executed by the Awarding Authority is required before the Awarding Authority is bound. An award may be cancelled any time by the Awarding Authority prior to execution in order to protect the public interest and integrity of the bidding process or for any other reason if, in the judgment of the Awarding Authority, the best interests of the Awarding Authority will be promoted thereby.

If a contract is not awarded within 45 days after the opening of proposals, bidders may file a written request with the Awarding Authority for the withdrawal of their bid, and the Awarding Authority will permit such withdrawal.

Requirement of Contract Bond. The Contractor shall furnish the Awarding Authority a performance and payment bond with good and sufficient sureties in the full amount of the contract as the penal sum. The surety shall be acceptable to the Awarding Authority, shall waive notice of any changes and extensions of time, and shall submit its bond on the form furnished by the Awarding Authority.

Execution of Contract. The contract shall be executed by the successful bidder and returned, together with the Contract Bond, within 15 days after the contract has been mailed to the bidder.

If the bidder to whom the award is made is a corporation organized under the laws of a State other than Illinois, the bidder shall furnish the Awarding Authority a copy of the corporation's Certificate of Authority to do business in the State of Illinois with the return of the executed contract and bond. Failure to furnish such evidence of a Certificate of Authority within the time required will be considered as just cause for the annulment of the award and the forfeiture of the proposal guaranty to the Awarding Authority, not as a penalty, but in payment of liquidated damages sustained as a result of such failure.

Failure to Execute Contract. If the contract is not executed by the Awarding Authority within 15 days following receipt from the bidder of the properly executed contracts and bonds, the bidder shall have the right to withdraw his/her bid without penalty.

Failure of the successful bidder to execute the contract and file acceptable bonds within 15 days after the contract has been mailed to the bidder shall be just cause for the cancellation of the award and the forfeiture of the proposal guaranty which shall become the property of the Awarding Authority, not as penalty, but in liquidation of damages sustained. Award may then be made to the next lowest responsible bidder, or the work may be readvertised and constructed under contract, or otherwise, as the Awarding Authority may decide.”

State of Illinois
Department of Transportation
Bureau of Local Roads and Streets

SPECIAL PROVISION
FOR
COOPERATION WITH UTILITIES

Effective: January 1, 1999
Revised: January 1, 2007

All references to Sections or Articles in this specification shall be construed to mean specific Section or Article of the Standard Specifications for Road and Bridge Construction, adopted by the Department of Transportation.

Replace Article 105.07 of the Standard Specifications with the following:

“105.07 Cooperation with Utilities. The adjustment of utilities consists of the relocation, removal, replacement, rearrangements, reconstruction, improvement, disconnection, connection, shifting, new installation or altering of an existing utility facility in any manner.

When the plans or special provisions include information pertaining to the location of underground utility facilities, such information represents only the opinion of the Department as to the location of such utilities and is only included for the convenience of the bidder. The Department assumes no responsibility in respect to the sufficiency or the accuracy of the information shown on the plans relative to the location of the underground utility facilities.

Utilities which are to be adjusted shall be adjusted by the utility owner or the owner's representative or by the Contractor as a contract item. Generally, arrangements for adjusting existing utilities will be made by the Department prior to project construction; however, utilities will not necessarily be adjusted in advance of project construction and, in some cases, utilities will not be removed from the proposed construction limits. When utility adjustments must be performed in conjunction with construction, the utility adjustment work will be shown on the plans and/or covered by Special Provisions.

When the Contractor discovers a utility has not been adjusted by the owner or the owner's representative as indicated in the contract documents, or the utility is not shown on the plans or described in the Special Provisions as to be adjusted in conjunction with construction, the Contractor shall not interfere with said utility, and shall take proper precautions to prevent damage or interruption of the utility and shall promptly notify the Engineer of the nature and location of said utility.

All necessary adjustments, as determined by the Engineer, of utilities not shown on the plans or not identified by markers, will be made at no cost to the Contractor except traffic structures, light poles, etc., that are normally located within the proposed construction limits as hereinafter defined will not be adjusted unless required by the proposed improvement.

(a) Limits of Proposed Construction for Utilities Paralleling the Roadway. For the purpose of this Article, limits of proposed construction for utilities extending in the same longitudinal direction as the roadway, shall be defined as follows:

- (1) The horizontal limits shall be a vertical plane, outside of, parallel to, and 600 mm (2 ft) distant at right angles from the plan or revised slope limits.

In cases where the limits of excavation for structures are not shown on the plans, the horizontal limits shall be a vertical plane 1.2 m (4 ft) outside the edges of structure footings or the structure where no footings are required.

- (2) The upper vertical limits shall be the regulations governing the roadbed clearance for the specific utility involved.
- (3) The lower vertical limits shall be the top of the utility at the depth below the proposed grade as prescribed by the governing agency or the limits of excavation, whichever is less.

(b) Limits of Proposed Construction for Utilities Crossing the Roadway. For the purpose of this Article, limits of proposed construction for utilities crossing the roadway in a generally transverse direction shall be defined as follows:

- (1) Utilities crossing excavations for structures that are normally made by trenching such as sewers, underdrains, etc. and all minor structures such as manholes, inlets, foundations for signs, foundations for traffic signals, etc., the limits shall be the space to be occupied by the proposed permanent construction unless otherwise required by the regulations governing the specific utility involved.
- (2) For utilities crossing the proposed site of major structures such as bridges, sign trusses, etc., the limits shall be as defined above for utilities extending in the same general direction as the roadway.

The Contractor may make arrangements for adjustment of utilities outside of the limits of proposed construction provided the Contractor furnishes the Department with a signed agreement with the utility owner covering the adjustments to be made. The cost of any adjustments made outside the limits of proposed construction shall be the responsibility of the Contractor unless otherwise provided.

The Contractor shall request all utility owners to field locate their facilities according to Article 107.31. The Engineer may make the request for location from the utility after receipt of notice from the Contractor. On request, the Engineer will make an inspection to verify that the utility company has field located its facilities, but will not assume responsibility for the accuracy of such work. The Contractor shall be responsible for maintaining the excavations or markers provided by the utility owners. This field location procedure may be waived if the utility owner has stated in writing to the Department it is satisfied the construction plans are sufficiently accurate. If the utility owner does not submit such statement to the Department, and they do not field locate their facilities in both horizontal and vertical alignment, the Engineer will authorize the Contractor in writing to proceed to locate the facilities in the most economical and reasonable manner, subject to the approval of the Engineer, and be paid according to Article 109.04.

The Contractor shall coordinate with any planned utility adjustment or new installation and the Contractor shall take all precautions to prevent disturbance or damage to utility facilities. Any failure on the part of the utility owner, or their representative, to proceed with any planned utility adjustment or new installation shall be reported promptly by the Contractor to the Engineer orally and in writing.

The Contractor shall take all necessary precautions for the protection of the utility facilities. The Contractor shall be responsible for any damage or destruction of utility facilities resulting from neglect, misconduct, or omission in the Contractor's manner or method of execution or nonexecution of the work, or caused by defective work or the use of unsatisfactory materials. Whenever any damage or destruction of a utility facility occurs as a result of work performed by the Contractor, the utility company will be immediately notified. The utility company will make arrangements to restore such facility to a condition equal to that existing before any such damage or destruction was done.

It is understood and agreed that the Contractor has considered in the bid all of the permanent and temporary utilities in their present and/or adjusted positions.

No additional compensation will be allowed for any delays, inconvenience, or damage sustained by the Contractor due to any interference from the said utility facilities or the operation of relocating the said utility facilities.

NOT FOR

State of Illinois
Department of Transportation
Bureau of Local Roads and Streets

SPECIAL PROVISION
FOR
INSURANCE

Effective: February 1, 2007
Revised: August 1, 2007

All references to Sections or Articles in this specification shall be construed to mean specific Section or Article of the Standard Specifications for Road and Bridge Construction, adopted by the Department of Transportation.

The Contractor shall name the following entities as additional insured under the Contractor's general liability insurance policy in accordance with Article 107.27:

The entities listed above and their officers, employees, and agents shall be indemnified and held harmless in accordance with Article 107.26.

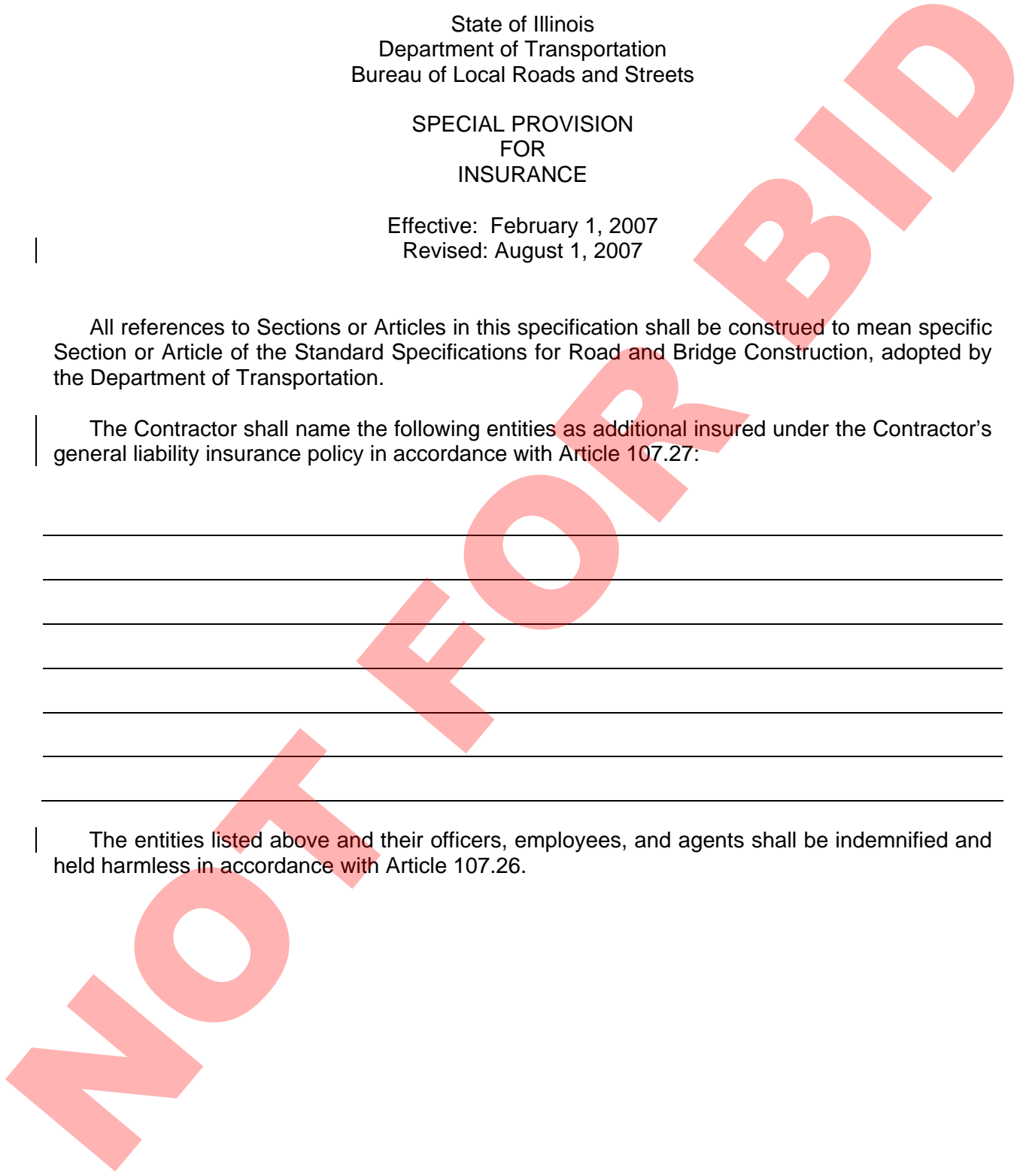

State of Illinois
DEPARTMENT OF TRANSPORTATION
Bureau of Local Roads & Streets

SPECIAL PROVISION
FOR
WAGES OF EMPLOYEES ON PUBLIC WORKS

Effective: January 1, 1999
Revised: January 1, 2012

1. Prevailing Wages. All wages paid by the Contractor and each subcontractor shall be in compliance with The Prevailing Wage Act (820 ILCS 130), as amended, except where a prevailing wage violates a federal law, order, or ruling, the rate conforming to the federal law, order, or ruling shall govern. The Contractor shall be responsible to notify each subcontractor of the wage rates set forth in this contract and any revisions thereto. If the Department of Labor revises the wage rates, the revised rate as provided by the public body shall apply to this contract and the Contractor will not be allowed additional compensation on account of said revisions.
2. Payroll Records. The Contractor and each subcontractor shall make and keep, for a period of not less than three years from the date of the last payment on a contract or subcontract, records of all laborers, mechanics, and other workers employed by them on the project; the records shall include each worker's name, address, telephone number when available, social security number, classification or classifications, the hourly wages paid in each pay period, the number of hours worked each day, and the starting and ending times of work each day. Upon seven business days' notice, the Contractor and each subcontractor shall make available for inspection and copying at a location within this State during reasonable hours, the payroll records to the public body in charge of the project, its officers and agents, the Director of Labor and his deputies and agents, and to federal, State, or local law enforcement agencies and prosecutors.
3. Submission of Payroll Records. The Contractor and each subcontractor shall no later than the tenth day of each calendar month file a certified payroll for the immediately preceding month with the public body in charge of the project, except that the full social security number and home address shall not be included on weekly transmittals. Instead the payrolls shall include an identification number for each employee (e.g., the last four digits of the employee's social security number). The certified payroll shall consist of a complete copy of the payroll records except starting and ending times of work each day may be omitted

The certified payroll shall be accompanied by a statement signed by the Contractor or subcontractor or an officer, employee, or agent of the contractor or subcontractor which avers that: (i) he or she has examined the certified payroll records required to be submitted by the Act and such records are true and accurate; (ii) the hourly rate paid to each worker is not less than the general prevailing rate of hourly wages required; and (iii) the Contractor or subcontractor is aware that filing a certified payroll that he or she knows to be false is a Class A misdemeanor.
4. Employees Interviews. The Contractor and each subcontractor shall permit his/her employees to be interviewed on the job, during working hours, by compliance investigators of the Department or the Department of Labor.

State of Illinois
Department of Transportation
Bureau of Local Roads and Streets

SPECIAL PROVISION
FOR
EQUIPMENT RENTAL RATES

Effective: January 1, 2012

All references to Sections or Articles in this specification shall be construed to mean a specific Section or Article of the Standard Specifications for Road and Bridge Construction, adopted by the Department of Transportation.

Replace Article 109.04(b)(4) with the following:

- "(4) Equipment. For any machinery or special equipment (other than small tools) the use of which has been authorized by the Engineer, the Contractor will be paid according to the latest revision of "SCHEDULE OF AVERAGE ANNUAL EQUIPMENT OWNERSHIP EXPENSE" and latest index factor as issued by the Illinois Department of Transportation. The equipment should be of a type and size reasonably required to complete the extra work."

ABV	ABOVE	CU YD	CUBIC YARD	HD	HEAD	PED	PEDESTAL	STD	STANDARD
A/C	ACCESS CONTROL	CULV	CULVERT	HDW	HEADWALL	PNT	POINT	SBI	STATE BOND ISSUE
AC	ACRE	C&G	CURB & GUTTER	HDUTY	HEAVY DUTY	PC	POINT OF CURVATURE	SR	STATE ROUTE
ADJ	ADJUST	D	DEGREE OF CURVE	ha	HECTARE	PI	POINT OF INTERSECTION OF HORIZONTAL CURVE	STA	STATION
AS	AERIAL SURVEYS	DC	DEPRESSED CURVE	HMA	HOT MIX ASPHALT	PRC	POINT OF REVERSE CURVE	SPBGR	STEEL PLATE BEAM GUARDRAIL
AGG	AGGREGATE	DET	DETECTOR	HWY	HIGHWAY	PT	POINT OF TANGENCY	SS	STORM SEWER
AH	AHEAD	DIA	DIAMETER	HORIZ	HORIZONTAL	POT	POINT ON TANGENT	STY	STORY
APT	APARTMENT	DIST	DISTRICT	HSE	HOUSE	POLYETH	POLYETHYLENE	STR	STREET
ASPH	ASPHALT	DOM	DOMESTIC	IL	ILLINOIS	PCC	PORTLAND CEMENT CONCRETE	e	STRUCTURE
AUX	AUXILIARY	DBL	DOUBLE	IMP	IMPROVEMENT	PP	POWER POLE OR PRINCIPAL POINT	S.E. RUN,	SUPERELEVATION RATE
AGS	AUXILIARY GAS VALVE (SERVICE)	DSFL	DOWNSIDE ELEVATION	IN DIA	INCH DIAMETER	PRM	PRIME	SURF	SUPERELEVATION RUNOFF LENGTH SURFACE
AVE	AVENUE	DSFL	DOWNSIDE FLOWLINE	INL	INLET	PE	PRIVATE ENTRANCE	SMK	SURVEY MARKER
AX	AXIS OF ROTATION	DR	DRAINAGE OR DRIVE	INST	INSTALLATION	PROF	PROFILE	T	TANGENT DISTANCE
BK	BACK	DI	DRAINAGE INLET OR DROP INLET	IDS	INTERSECTION DESIGN STUDY	PGL	PROFILE GRADELINE	T.R.	TANGENT RUNOUT DISTANCE
B-B	BACK TO BACK	DRV	DRIVEWAY	INV	INVERT	PROJ	PROJECT	TEL	TELEPHONE
BKPL	BACKPLATE	DCT	DUCT	IP	IRON PIPE	P.C.	PROPERTY CORNER	TB	TELEPHONE BOX
B	BARN	EA	EACH	IR	IRON ROD	PL	PROPERTY LINE	TP	TELEPHONE POLE
BARR	BARRICADE	EB	EASTBOUND	JT	JOINT	PR	PROPOSED	TEMP	TEMPORARY
BGN	BEGIN	EOP	EDGE OF PAVEMENT	kg	KILOGRAM	R	RADIUS	TBM	TEMPORARY BENCH MARK
BM	BENCHMARK	E-CL	EDGE TO CENTERLINE	km	KILOMETER	RR	RAILROAD	TD	TILE DRAIN
BIND	BINDER	E-E	EDGE TO EDGE	LS	LANDSCAPING	RRS	RAILROAD SPIKE	TBE	TO BE EXTENDED
BIT	BITUMINOUS	EL	ELEVATION	LN	LANE	RPS	REFERENCE POINT STAKE	TBR	TO BE REMOVED
BTM	BOTTOM	ENTR	ENTRANCE	LT	LEFT	REF	REFLECTIVE	TBS	TO BE SAVED
BLVD	BOULEVARD	EXC	EXCAVATION	LP	LIGHT POLE	RCCP	REINFORCED CONCRETE CULVERT PIPE	TVP	TOWNSHIP
BRK	BRICK	EX	EXISTING	LGT	LIGHTING	REINF	REINFORCEMENT	TR	TOWNSHIP ROAD
BBOX	BUFFALO BOX	EXPWAY	EXPRESSWAY	LF	LINAL FEET OR LINEAR FEET	REM	REMOVAL	TS	TRAFFIC SIGNAL
BLDG	BUILDING	E	EXTERNAL DISTANCE OF HORIZONTAL CURVE	L	LITER OR CURVE LENGTH	RC	REMOVE CROWN	TSCB	TRAFFIC SIGNAL CONTROL BOX
CB	CAST IRON PIPE	E	OFFSET DISTANCE TO VERTICAL CURVE	LC	LONG CHORD	REP	REPLACEMENT	TSC	TRAFFIC SYSTEMS CENTER
CB	CATCH BASIN	F-F	FACE TO FACE	LNG	LONGITUDINAL	REST	RESTAURANT	TRVS	TRANSVERSE
C-C	CENTER TO CENTER	FA	FEDERAL AID	L SUM	LUMP SUM	RESURF	RESURFACING	TRVL	TRAVEL
CL	CENTERLINE OR CLEARANCE	FAI	FEDERAL AID INTERSTATE	MACH	MACHINE	RET	RETAINING	TRN	TURN
CL-E	CENTERLINE TO EDGE	FAP	FEDERAL AID PRIMARY	MB	MAIL BOX	RT	RIGHT	TY	TYPE
CL-F	CENTERLINE TO FACE	FAS	FEDERAL AID SECONDARY	MH	MANHOLE	ROW	RIGHT-OF-WAY	T-A	TYPE A
CTS	CENTERS	FAUS	FEDERAL AID URBAN SECONDARY	MATL	MATERIAL	RD	ROAD	T-P	TYPICAL
CERT	CERTIFIED	FP	FENCE POST	MED	MEDIAN	RDWY	ROADWAY	UNDGND	UNDERGROUND
CHSLD	CHISELED	FE	FIELD ENTRANCE	m	METER	RTE	ROUTE	USGS	U.S. GEOLOGICAL SURVEY
CS	CITY STREET	FH	FIRE HYDRANT	METH	METHOD	SAN	SANITARY	USEL	UPSTREAM ELEVATION
CP	CLAY PIPE	FL	FLOW LINE	M	MID-ORDINATE	SANS	SANITARY SEWER	USFL	UPSTREAM FLOWLINE
CLSD	CLOSED	FB	FOOT BRIDGE	mm	MILLIMETER	SEC	SECTION	UTIL	UTILITY
CLID	CLOSED LID	FDN	FOUNDATION	mm DIA	MILLIMETER DIAMETER	SEED	SEEDING	VBOX	VALVE BOX
CT	COAT OR COURT	FR	FRAME	MIX	MIXTURE	SHAP	SHAPING	VV	VALVE VAULT
COMB	COMBINATION	F&G	FRAME & GRATE	MOD	MODIFIED	S	SHED	VLT	VAULT
C	COMMERCIAL BUILDING	FRWAY	FREEWAY	MFT	MOTOR FUEL TAX	SH	SHEET	VEH	VEHICLE
CE	COMMERCIAL ENTRANCE	GAL	GALLON	N & BC	NAIL & BOTTLE CAP	SHLD	SHOULDER	VP	VENT PIPE
CONC	CONCRETE	GALV	GALVANIZED	N & C	NAIL & CAP	SW	SIDEWALK OR SOUTHWEST	VERT	VERTICAL
CONST	CONSTRUCT	G	GARAGE	N & W	NAIL & WASHER	SIG	SIGNAL	VC	VERTICAL CURVE
CONTD	CONTINUED	GM	GAS METER	NOAA	NATIONAL OCEANIC ATMOSPHERIC ADMINISTRATION	SOD	SODDING	VPC	VERTICAL POINT OF CURVATURE
CONT	CONTINUOUS	GV	GAS VALVE	NC	NORMAL CROWN	SM	SOLID MEDIAN	VPI	VERTICAL POINT OF INTERSECTION
COR	CORNER	GRAN	GRANULAR	NB	NORTHBOUND	SB	SOUTHBOUND	VPT	VERTICAL POINT OF TANGENCY
CORR	CORRUGATED	GR	GRATE	NE	NORTHEAST	SE	SOUTHEAST	WM	WATER METER
CMP	CORRUGATED METAL PIPE	GRVL	GRAVEL	NW	NORTHWEST	SPL	SPECIAL	WV	WATER VALVE
CNTY	COUNTY	GND	GROUND	OLID	OPEN LID	SD	SPECIAL DITCH	WMAIN	WATER MAIN
CH	COUNTY HIGHWAY	GUT	GUTTER	PAT	PATTERN	SQ FT	SQUARE FEET	WB	WESTBOUND
CSE	COURSE	GP	GUY POLE	PVD	PAVED	m ²	SQUARE METER	WILDFL	WILDFLOWERS
XSECT	CROSS SECTION	GW	GUY WIRE	PVMT	PAVEMENT	mm ²	SQUARE MILLIMETER	W	WITH
m ³	CUBIC METER	HH	HANDHOLE	PM	PAVEMENT MARKING	SQ YD	SQUARE YARD	WO	WITHOUT
mm ³	CUBIC MILLIMETER	HATCH	HATCHING			STB	STABILIZED		

Illinois Department of Transportation	
PASSED	January 1, 2011
<i>Michael Beard</i>	
ENGINEER OF POLICY AND PROCEDURES	
APPROVED	January 1, 2011
<i>Scott Smith</i>	
ENGINEER OF DESIGN AND ENVIRONMENT	











DATE	REVISIONS
1-1-11	Updated abbreviations and symbols.
1-1-08	Updated abbreviations and symbols.



















STANDARD SYMBOLS, ABBREVIATIONS AND PATTERNS

(Sheet 1 of 8)

STANDARD 000001-06

<u>ADJUSTMENT ITEMS</u>	<u>EX</u>	<u>PR</u>
Structure To Be Adjusted		ADJ
Structure To Be Cleaned		C
Main Structure To Be Filled		FM
Structure To Be Filled		F
Structure To Be Filled Special		FSP
Structure To Be Removed		R
Structure To Be Reconstructed		REC
Structure To Be Reconstructed Special		RSP
Frame and Grate To Be Adjusted		A
Frame and Lid To Be Adjusted		A
Domestic Service Box To Be Adjusted		A
Valve Vault To Be Adjusted		A
Special Adjustment		SP
Item To Be Abandoned		AB
Item To Be Moved		M
Item To Be Relocated		REL
Pavement Removal and Replacement		

<u>ALIGNMENT ITEMS</u>	<u>EX</u>	<u>PR</u>
Baseline	_____	_____
Centerline	_____	_____
Centerline Break Circle	○	⊙
Baseline Symbol	\	\
Centerline Symbol	⊕	⊕
PI Indicator	△	△
Point Indicator	○	○
Horizontal Curve Data (Half Size)	CURVE P.I. STA= ΔS= D= R= T= L= E= e= Y.P.S.= S.E. RUN= P.C. STA= P.T. STA=	CURVE P.I. STA= ΔS= D= R= T= L= E= e= T.P.R.= S.E. RUN= P.C. STA= P.T. STA=
<u>BOUNDARIES ITEMS</u>	<u>EX</u>	<u>PR</u>
Dashed Property Line	- - - - -	- - - - -
Solid Property/Lot Line	_____	_____
Section/Grant Line	- - - - -	- - - - -
Quarter Section Line	- - - - -	- - - - -
Quarter/Quarter Section Line	_____	_____
County/Township Line	- - - - -	- - - - -
State Line	- - - - -	- - - - -
Iron Pipe Found	○	○
Iron Pipe Set	●	●
Survey Marker		
Property Line Symbol	⊕	⊕
Same Ownership Symbol (Half Size)		
Northwest Quarter Corner (Half Size)		
Section Corner (Half Size)		
Southeast Quarter Corner (Half Size)		

<u>CONTOUR ITEMS</u>	<u>EX</u>	<u>PR</u>
Approx. Index Line	- - - - -	- - - - -
Approx. Intermediate Line	- - - - -	- - - - -
Index Contour	_____	_____
Intermediate Contour	_____	_____
<u>DRAINAGE ITEMS</u>	<u>EX</u>	<u>PR</u>
Channel or Stream Line	- - - - -	- - - - -
Culvert Line	- - - - -	_____
Grading & Shaping Ditches	- - - - -	- - - - -
Drainage Boundary Line		
Paved Ditch		
Aggregate Ditch		
Pipe Underdrain		
Storm Sewer		
Flowline	⊕	⊕
Ditch Check		
Headwall	-	∩
Inlet	□	■
Manhole	⊙	⊙
Summit	↔	↔
Roadway Ditch Flow		
Swale		
Catch Basin	○	●
Culvert End Section	◁	◁
Water Surface Indicator	▽	▽
Riprap		

**STANDARD SYMBOLS,
ABBREVIATIONS
AND PATTERNS**
(Sheet 2 of 8)

STANDARD 000001-06

Illinois Department of Transportation

PASSED January 1, 2011
Michael Beard
ENGINEER OF POLICY AND PROCEDURES

APPROVED January 1, 2011
Scott Smith
ENGINEER OF DESIGN AND ENVIRONMENT

ISSUED 1-1-11

EROSION & SEDIMENT CONTROL ITEMS		EX	PR	NON-HIGHWAY IMPROVEMENT ITEMS		EX	PR	EXISTING LANDSCAPING ITEMS (contd.)		EX	PR
Cleaning & Grading Limits				Noise Attn./Levee				Seeding Class 5			
Dike				Field Line				Seeding Class 7			
Erosion Control Fence				Fence				Seedlings Type 1			
Perimeter Erosion Barrier				Base of Levee				Seedlings Type 2			
Temporary Fence				Mallbox				Sodding			
Ditch Check Temporary				Multiple Mallboxes				Mowstake w/Sign			
Ditch Check Permanent				Pay Telephone				Tree Trunk Protection			
Inlet & Pipe Protection				Advertising Sign				Evergreen Tree			
Sediment Basin								Shade Tree			
Erosion Control Blanket				LANDSCAPING ITEMS		EX	PR	LIGHTING		EX	PR
Fabric Formed Concrete Revetment Mat				Contour Mounding Line				Duct			
Turf Reinforcement Mat				Fence				Conduit			
Mulch Temporary				Fence Post				Electrical Aerial Cable			
Mulch Method 1				Shrubs				Electrical Buried Cable			
Mulch Method 2 Stabilized				Mowline				Controller			
Mulch Method 3 Hydraulic				Perennial Plants				Underpass Luminaire			
				Seeding Class 2				Power Pole			
				Seeding Class 2A							
				Seeding Class 4							
				Seeding Class 4 & 5 Combined							

Illinois Department of Transportation
 PASSED January 1, 2011
Michael Beard
 ENGINEER OF POLICY AND PROCEDURES
 APPROVED January 1, 2011
Spencer
 ENGINEER OF DESIGN AND ENVIRONMENT

STANDARD SYMBOLS, ABBREVIATIONS AND PATTERNS
 (Sheet 3 of 8)
STANDARD 000001-06

**LIGHTING
(contd.)**

EX

PR

Pull Point



Handhole



Heavy Duty Handhole



Junction Box



Light Unit Comb.



Electrical Ground



Traffic Flow Arrow



High Mast Pole
(Half Size)



Light Unit-1



PAVEMENT (MISC.)

EX

PR

Keyed Long. Joint



Keyed Long. Joint w/Tie Bars



Sawed Long. Joint w/Tie Bars

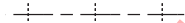

Bituminous Shoulder



Bituminous Taper



Stabilized Driveway



Widening



PAVEMENT MARKINGS

EX

PR

Bike Lane Symbol



Bike Lane Text



Handicap Symbol



RR Crossing



Raised Marker Amber 1 Way

Raised Marker Amber 2 Way

Raised Marker Crystal 1 Way

Two Way Turn Left

Shoulder Diag. Pattern

Sklp-Dash White

Sklp-Dash Yellow

Stop Line

Solid Line

Double Centerline

Dotted Lines

CL 2Ln 2Way
RRPM 12.2 m (40') o.c.

CL 2Ln 2Way
RRPM 80' (24.4 m) o.c.

CL Multilane Div.
RRPM 40' (12.2 m) o.c.

CL Multilane Div.
RRPM 80' (24.4 m) o.c.

CL Multilane Div. Dbl.
RRPM 80' (24.4 m) o.c.

CL Multilane Undiv.

Two Way Turn Left Line

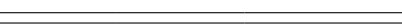
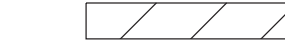
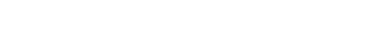

Illinois Department of Transportation

PASSED January 1, 2011
Michael Beard
 ENGINEER OF POLICY AND PROCEDURES

APPROVED January 1, 2011
Spencer
 ENGINEER OF DESIGN AND ENVIRONMENT

DESIGN CENTER 1-4-11

**STANDARD SYMBOLS,
ABBREVIATIONS
AND PATTERNS**
 (Sheet 4 of 8)

STANDARD 000001-06

PAVEMENT MARKINGS
(contd.)

Urban Combination Left

EX



Urban Combination Right



Urban Left Turn Arrow



Urban Right Turn Arrow



Urban Left Turn Only



Urban Right Turn Only



Urban Thru Only



Urban U-Turn



Urban Combined U-Turn



Rural Combination Left



Rural Combination Right



Rural Left Turn Arrow



Rural Right Turn Arrow



Rural Left Turn Only



Rural Right Turn Only



Rural Thru Only



PR



RAILROAD ITEMS

EX

PR

Abandoned Railroad



Railroad

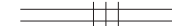

Railroad Point



Control Box



Crossing Gate



Flashing Signal



Railroad Cant, Mast Arm



Crossbuck



REMOVAL ITEMS

EX

PR

Removal TIC



Bituminous Removal



Hatch Pattern



Tree Removal Single



RIGHT OF WAY ITEMS

EX

PR

Future ROW Corner Monument



ROW Marker



ROW Line



Easement

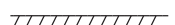
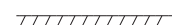

Temporary Easement

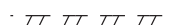

**STANDARD SYMBOLS,
ABBREVIATIONS
AND PATTERNS**

(Sheet 5 of 8)

STANDARD 000001-06

Illinois Department of Transportation

PASSED January 1, 2011
Michael Beard
ENGINEER OF POLICY AND PROCEDURES

APPROVED January 1, 2011
Spencer
ENGINEER OF DESIGN AND ENVIRONMENT

ISSUED 1-1-11

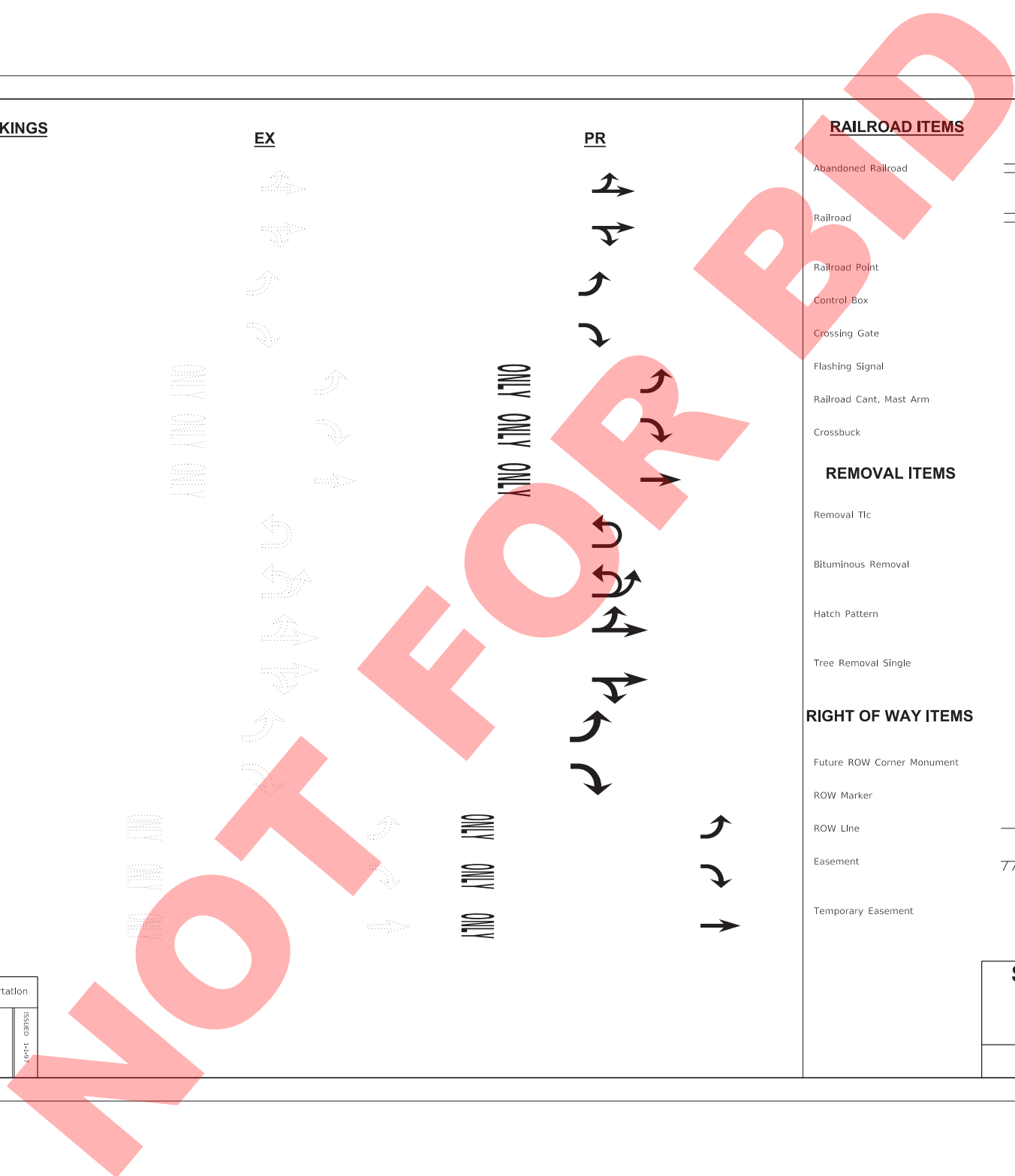

**RIGHT OF WAY ITEMS
(contd.)**

	EX	PR
Access Control Line	— — — — —	— AC — — — — —
Access Control Line & ROW	— — — — —	— AC — — — — — AC — — — — —
Access Control Line & ROW with Fence	— — — — —	— AC — — — — — AC — — — — —
Excess ROW Line		— XS — — — — —

ROADWAY PLAN ITEMS

	EX	PR
Cable Barrier	— ○ — ○ — ○ — ○ —	— ■ — ■ — ■ — ■ —
Concrete Barrier	— — — — —	— — — — —
Edge of Pavement	— — — — —	— — — — —
Bit Shoulders, Medians and C&G Line	— — — — —	— — — — —
Aggregate Shoulder	— — — — —	— — — — —
Sidewalks, Driveways	— — — — —	— — — — —
Guardrail	— □ — □ — □ — □ —	— ■ — ■ — ■ — ■ —
Guardrail Post	○	○
Traffic Sign	⊥	⊥
Corrugated Median	▨ ▨ ▨ ▨ ▨	▨ ▨ ▨ ▨ ▨
Impact Attenuator		○ ○ ○ ○ ○
North Arrow with District Office (Half Size)		
Match Line		— STA. 45+00 —
Slope Limit Line	— — — — —	
Typical Cross-Section Line	— — — — —	

ROADWAY PROFILES

	EX	PR
P.I. Indicator	△	△
Point Indicator	○	○
Earthworks Balance Point		⊙
Begin Point		◐
Vert. Curve Data	VPI = ELEV = L = E =	VPI = ELEV = L = E =
Ditch Profile Left Side	— — — — —	— — — — —
Ditch Profile Right Side	— — — — —	— — — — —
Roadway Profile Line	— — — — —	— — — — —
Storm Sewer Profile Left Side	— — — — —	— — — — —
Storm Sewer Profile Right Side	— — — — —	— — — — —

SIGNING ITEMS

	EX	PR
Cone, Drum or Barricade		○
Barricade Type II		▨ ▨ ▨ ▨ ▨
Barricade Type III		⊥
Barricade With Edge Line		— ○ — ○ — ○ — ○ —
Flashing Light Sign		○
Panels I		▨ ▨ ▨ ▨ ▨
Panels II		▨ ▨ ▨ ▨ ▨
Direction of Traffic		→
Sign Flag (Half Size)		◇

**SIGNING ITEMS
(contd.)**

	EX	PR
Reverse Left W1-4L (Half Size)		⬇
Reverse Right W1-4R (Half Size)		⬆
Two Way Traffic Sign W6-3 (Half Size)		↕
Detour Ahead W20-2(O) (Half Size)		⬇
Left Lane Closed Ahead W20-5L(O) (Half Size)		⬇
Right Lane Closed Ahead W20-5R(O) (Half Size)		⬆
Road Closed Ahead W20-3(O) (Half Size)		⬇
Road Construction Ahead W20-1-(O) (Half Size)		⬆
Single Lane Ahead (Half Size)		⬇
Transition Left W4-2L (Half Size)		↙
Transition Right W4-2R (Half Size)		↘

Illinois Department of Transportation

PASSED January 1, 2011
Michael Beard
 ENGINEER OF POLICY AND PROCEDURES

APPROVED January 1, 2011
Spencer
 ENGINEER OF DESIGN AND ENVIRONMENT

ISSUED 1-1-11

**STANDARD SYMBOLS,
ABBREVIATIONS
AND PATTERNS**
 (Sheet 6 of 8)

STANDARD 000001-06

**SIGNING ITEMS
(contd.)**

EX

PR

One Way Arrow Lrg. W1-6-(O)
(Half Size)



Two Way Arrow Large W1-7-(O)
(Half Size)



Detour M4-10L-(O)
(Half Size)



Detour M4-10R-(O)
(Half Size)



One Way Left R6-1L
(Half Size)



One Way Right R6-1R
(Half Size)



Left Turn Lane R3-1100L
(Half Size)



Keep Left R4-7AL
(Half Size)



Keep Left R4-7BL
(Half Size)



Keep Right R4-7AR
(Half Size)



Keep Right R4-7BR
(Half Size)



Stop Here On Red R10-6-AL
(Half Size)



Stop Here On Red R10-6-AR
(Half Size)



No Left Turn R3-2
(Half Size)



No Right Turn R3-1
(Half Size)



Road Closed R11-2
(Half Size)



Road Closed Thru Traffic R11-2
(Half Size)



STRUCTURES ITEMS

EX

PR

Box Culvert Barrel



Box Culvert Headwall



Bridge Pler



Bridge



Retaining Wall



Temporary Sheet Piling



**TRAFFIC SHEET
ITEMS**

EX

PR

Cable Number



Left Turn Green



Left Turn Yellow



Signal Backplate



Signal Section 8" (200 mm)



Signal Section 12" (300 mm)



Walk/Don't Walk Letters



Walk/Don't Walk Symbols



**TRAFFIC SIGNAL
ITEMS**

EX

PR

Galv. Steel Conduit



Underground Cable



Detector Loop Line



Detector Loop Large



Detector Loop Small



Detector Loop Quadrapole



Illinois Department of Transportation

PASSED January 1, 2011
Michael Beard
ENGINEER OF POLICY AND PROCEDURES

APPROVED January 1, 2011
Scott Smith
ENGINEER OF DESIGN AND ENVIRONMENT

152151
1-10-11

**STANDARD SYMBOLS,
ABBREVIATIONS
AND PATTERNS**
(Sheet 7 of 8)

STANDARD 000001-06

TRAFFIC SIGNAL ITEMS (contd.)	EX	PR
Detector Raceway		
Aluminum Mast Arm		
Steel Mast Arm		
Veh. Detector Magnetic		
Conduit Splice		
Controller		
Gulfbox Junction		
Wood Pole		
Temp. Signal Head		
Handhole		
Double Handhole		
Heavy Duty Handhole		
Junction Box		
Ped. Pushbutton Detector		
Ped. Signal Head		
Power Pole Service		
Priority Veh. Detector		
Signal Head		
Signal Head w/Backplate		
Signal Post		
Closed Circuit TV		
Video Detector System		

UNDERGROUND UTILITY ITEMS	EX	PR	ABANDONED
Cable TV			
Electric Cable			
Fiber Optic			
Gas Pipe			
Oil Pipe			
Sanitary Sewer			
Telephone Cable			
Water Pipe			

UTILITIES ITEMS	EX	PR
Controller		
Double Handhole		
Fire Hydrant		
GuyWire or Deadman Anchor		
Handhole		
Heavy Duty Handhole		
Junction Box		
Light Pole		
Manhole		
Pipeline Warning Sign		
Power Pole		
Power Pole with Light		
Sanitary Sewer Cleanout		
Splice Box Above Ground		
Telephone Splice Box Above Ground		
Telephone Pole		

UTILITY ITEMS (contd.)	EX	PR
Traffic Signal		
Traffic Signal Control Box		
Water Meter		
Water Meter Valve Box		
Profile Line		
Aerial Power Line		

VEGETATION ITEMS	EX	PR
Deciduous Tree		
Bush or Shrub		
Evergreen Tree		
Stump		
Orchard/Nursery Line		
Vegetation Line		
Woods & Bush Line		

WATER FEATURE ITEMS	EX	PR
Stream or Drainage Ditch		
Waters Edge		
Water Surface Indicator		
Water Point		
Disappearing Ditch		
Marsh		
Marsh/Swamp Boundary		

Illinois Department of Transportation

PASSED January 1, 2011
Michael Beard
 ENGINEER OF POLICY AND PROCEDURES

APPROVED January 1, 2011
Scott Smith
 ENGINEER OF DESIGN AND ENVIRONMENT

ISSUED 1-1-11

STANDARD SYMBOLS, ABBREVIATIONS AND PATTERNS
 (Sheet 8 of 8)

STANDARD 000001-06

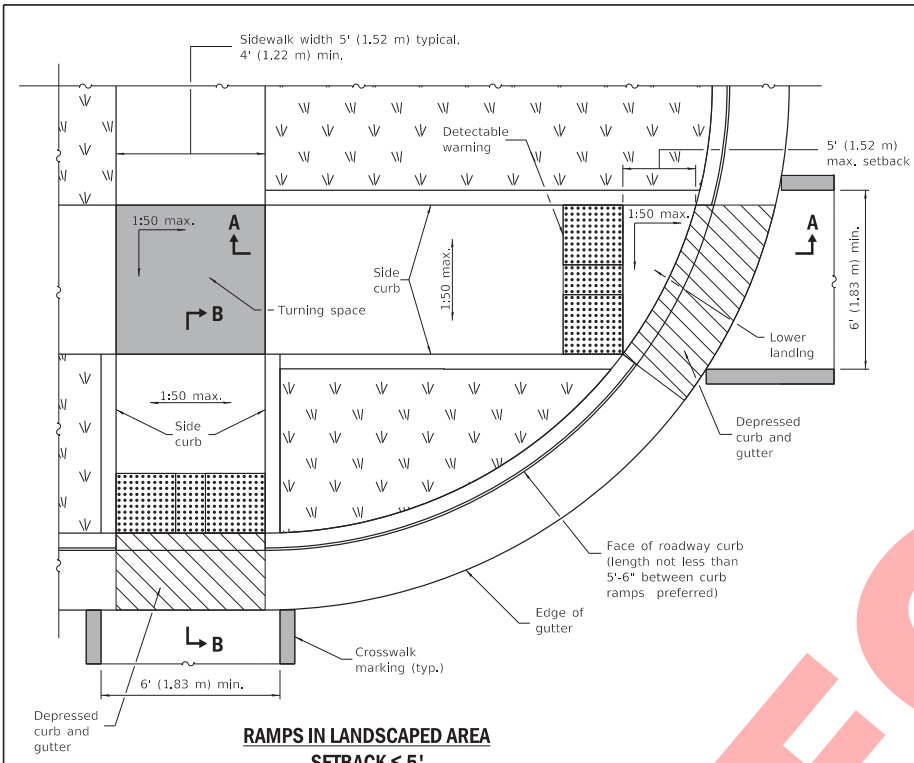

**RAMPS IN LANDSCAPED AREA
SETBACK ≤ 5'**

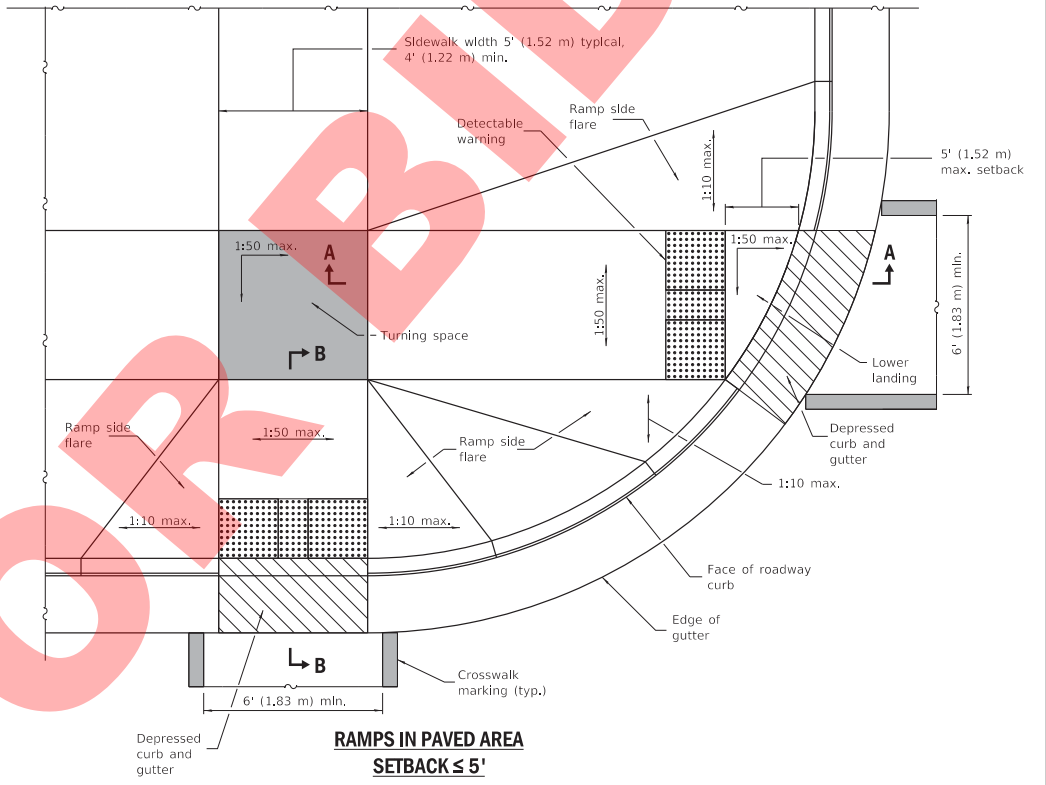

**RAMPS IN PAVED AREA
SETBACK ≤ 5'**

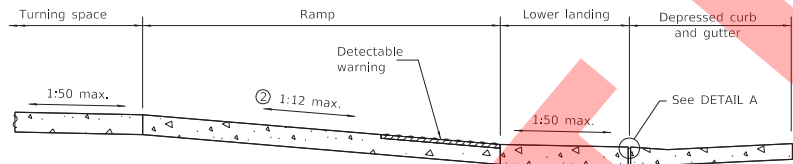

SECTION A-A

② The running slope of the curb ramp shall not require the ramp length to exceed 15' (4.5 m).

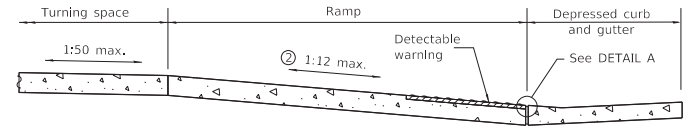

SECTION B-B

② The running slope of the curb ramp shall not require the ramp length to exceed 15' (4.5 m).

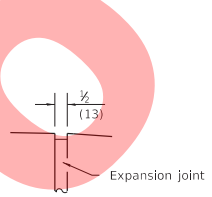

DETAIL A

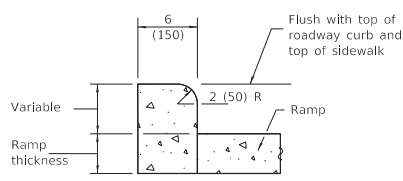

SIDE CURB DETAIL

Illinois Department of Transportation

PASSED January 1, 2018

Michael Beard
ENGINEER OF POLICY AND PROCEDURES

APPROVED January 1, 2018

Maureen M. Behr
ENGINEER OF DESIGN AND ENVIRONMENT

DESIGNED 1-14-18

DATE	REVISIONS
1-1-18	Omitted diagonal slope at turning spaces and lower landings.
1-1-17	Added 2' dimension to det. warnings for setbacks greater than 5'.

See Sheet 2 for GENERAL NOTES.

**PERPENDICULAR CURB RAMPS
FOR SIDEWALKS**

(Sheet 1 of 2)

STANDARD 424001-10

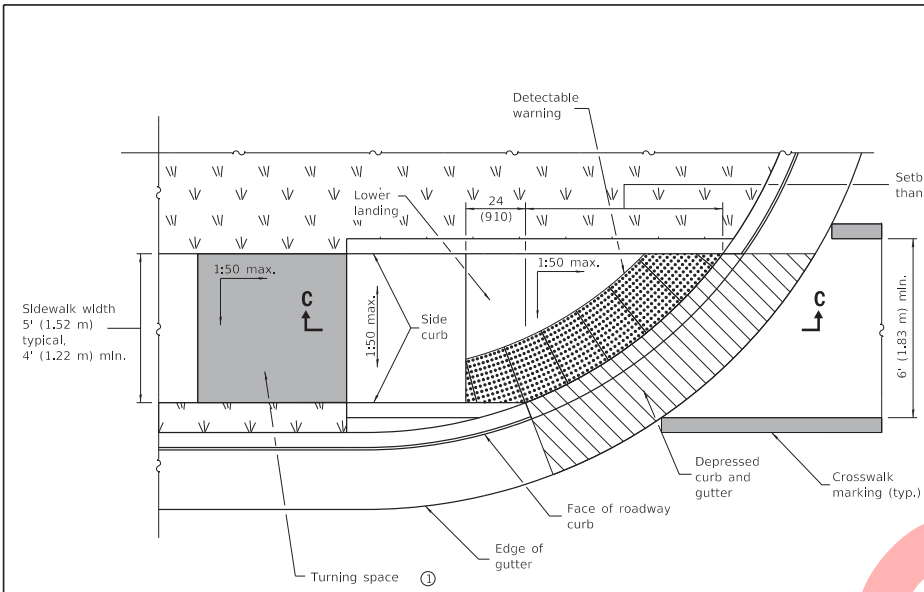

**RAMP IN LANDSCAPED AREA
SETBACK > 5'**

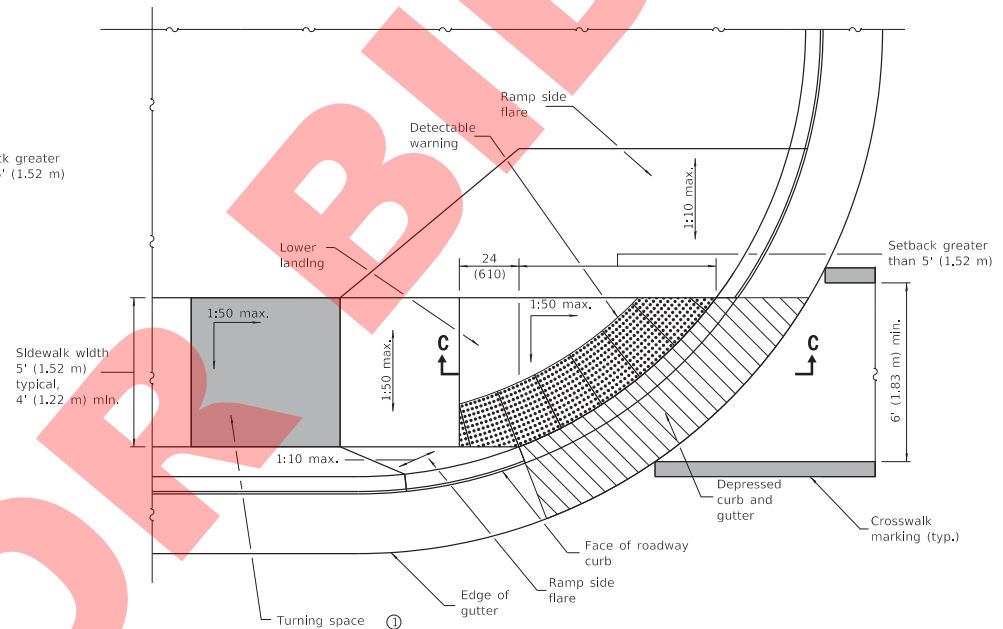

**RAMP IN PAVED AREA
SETBACK > 5'**

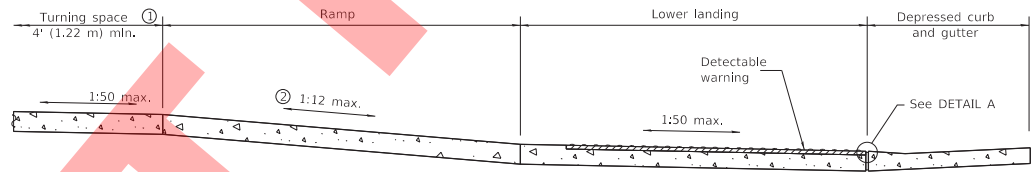

SECTION C-C

- ① Turning space not required for ramp slopes flatter than 1:20.
- ② The running slope of the curb ramp shall not require the ramp length to exceed 15' (4.5 m).

GENERAL NOTES

All slope ratios are expressed as units of vertical displacement to units of horizontal displacement (V:H).

Where the turning space is constrained on a side opposite a ramp, the minimum length of the turning space in the direction of the ramp-run shall be 5' (1.52 m).

Where 1:50 maximum slope is shown, 1:64 is preferred.

See Standard 606001 for details of depressed curb adjacent to curb ramp.

All dimensions are in inches (millimeters) unless otherwise shown.

**PERPENDICULAR CURB RAMPS
FOR SIDEWALKS**

(Sheet 2 of 2)

STANDARD 424001-10

Illinois Department of Transportation	
PASSED	January 1, 2018
<i>Michael Beard</i>	
ENGINEER OF POLICY AND PROCEDURES	
APPROVED	January 1, 2018
<i>Maureen M. Behr</i>	
ENGINEER OF DESIGN AND ENVIRONMENT	

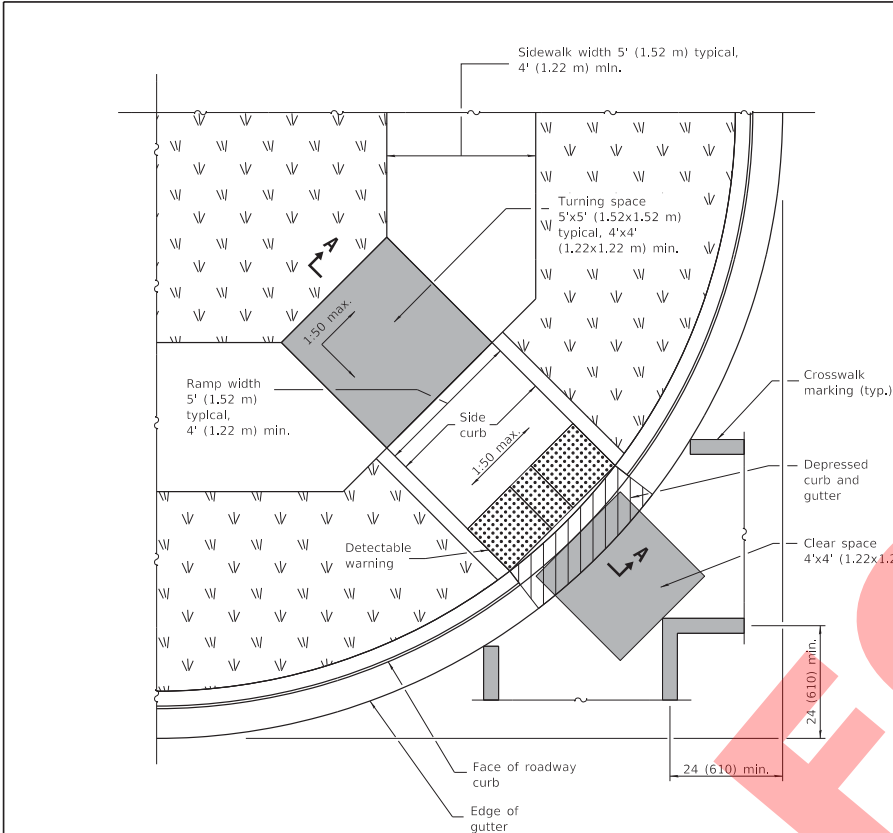

RAMP IN LANDSCAPED AREA

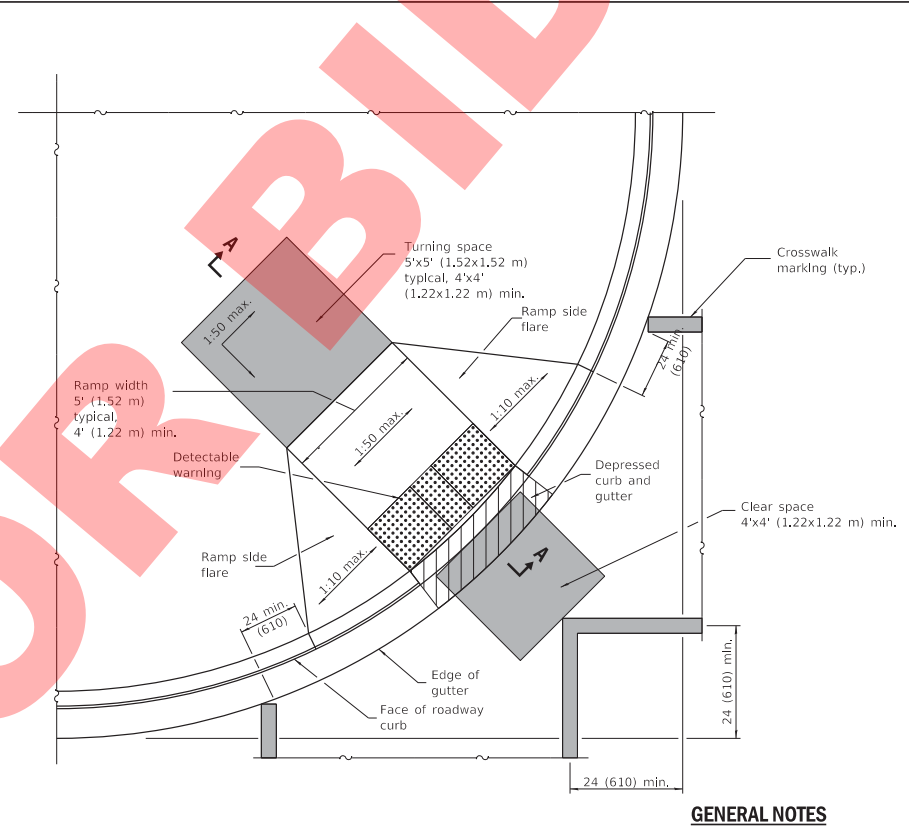

RAMP IN PAVED AREA

GENERAL NOTES

This Standard shall only be used for curb radii of 20 ft. (6.1 m) or greater.

Where the turning space is constrained on a side opposite a ramp, the minimum length of the turning space in the direction of the ramp-run shall be 5' (1.52 m).

Where 1:50 maximum slope is shown, 1:64 is preferred.

All slope ratios are expressed as units of vertical displacement to units of horizontal displacement (V:H).

See Standard 606001 for details of depressed curb adjacent to curb ramp.

All dimensions are in inches (millimeters) unless otherwise shown.

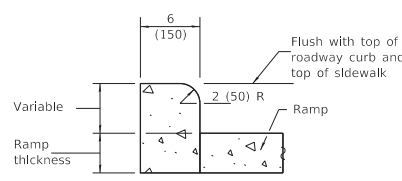

SIDE CURB DETAIL

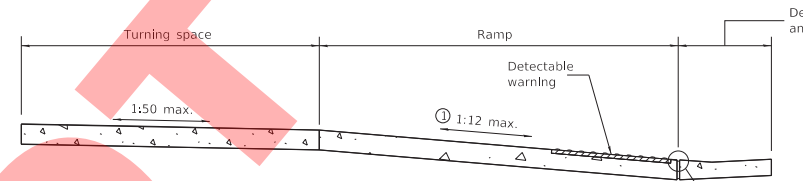

SECTION A-A

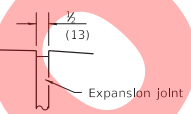

DETAIL A

Illinois Department of Transportation

PASSED January 1, 2018
Michael Beard
 ENGINEER OF POLICY AND PROCEDURES

APPROVED January 1, 2018
Maureen M. O'Connell
 ENGINEER OF DESIGN AND ENVIRONMENT

DATE	REVISIONS
1-1-18	Omitted diagonal slope at turning spaces.
1-1-15	Changed 'Upper landing' to 'Turning space'. Added note reg. const. turning space.

DIAGONAL CURB RAMPS FOR SIDEWALKS

STANDARD 424006-03

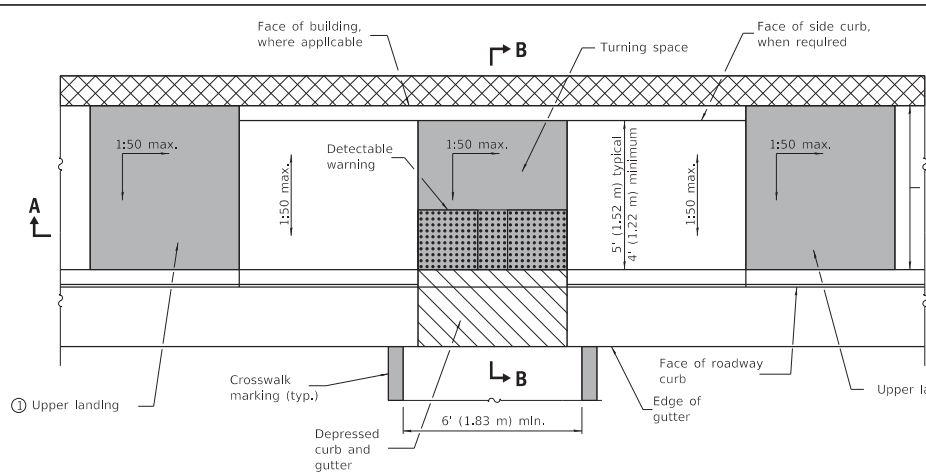

PARALLEL MID-BLOCK CURB RAMP

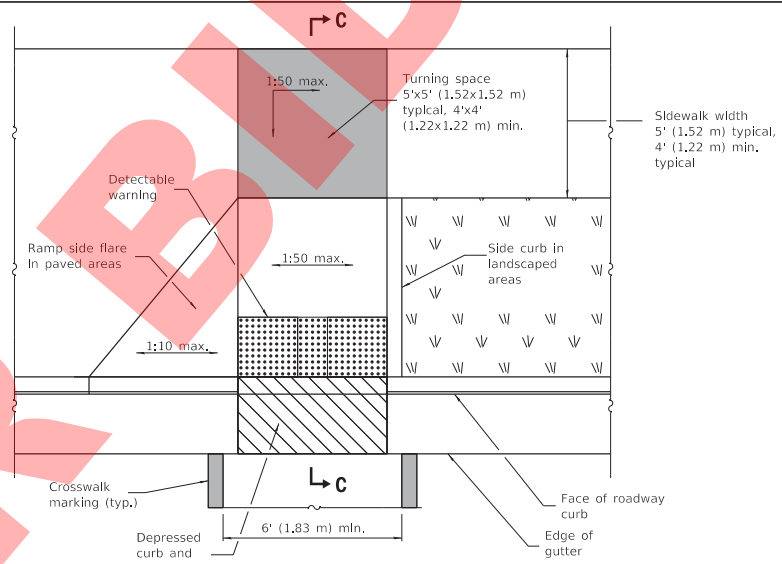

PERPENDICULAR MID-BLOCK CURB RAMP

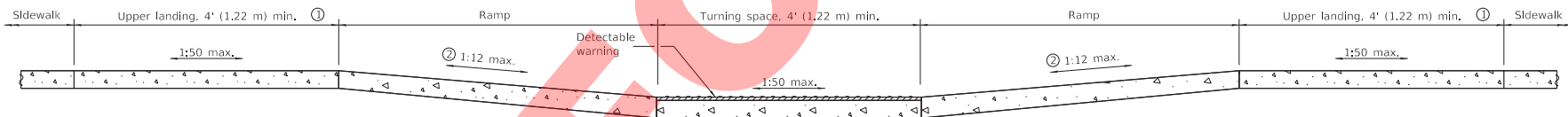

SECTION A-A

- ① Upper landing(s) not required for ramp slopes flatter than 1:20.
- ② The running slope of the curb ramp shall not require the ramp length to exceed 15' (4.5 m).

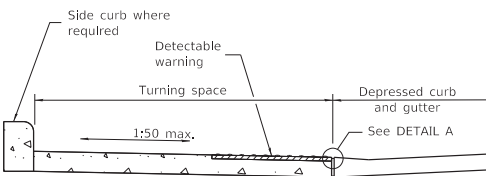

SECTION B-B

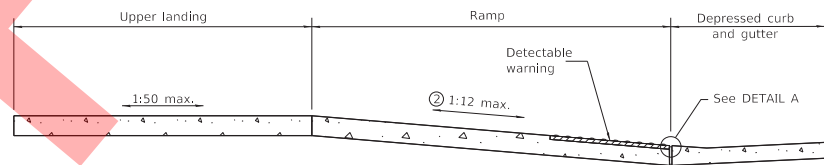

SECTION C-C

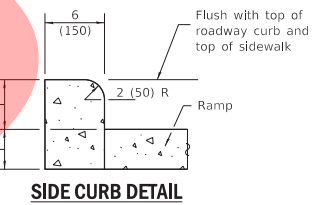

SIDE CURB DETAIL

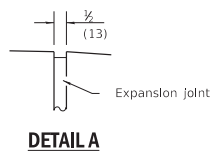

DETAIL A

GENERAL NOTES

All slope ratios are expressed as units of vertical displacement to units of horizontal displacement (V:H).

Where the turning space is constrained on a side opposite a ramp, the minimum length of the turning space in the direction of the ramp-run shall be 5' (1.52 m).

Where 1:50 maximum slope is shown, 1:64 is preferred.

See Standard 606001 for details of depressed curb adjacent to curb ramp.

All dimensions are in inches (millimeters) unless otherwise shown.

DATE	REVISIONS
1-1-18	Omitted diagonal slope at turning spaces and upper landings.
1-1-17	Revised sidewalk width to include 24 (610) buffer behind curb.

MID-BLOCK CURB RAMPS FOR SIDEWALKS

STANDARD 424016-04

Illinois Department of Transportation

PASSED January 1, 2018
Michael Beard
 ENGINEER OF POLICY AND PROCEDURES

APPROVED January 1, 2018
Maureen M. Peltz
 ENGINEER OF DESIGN AND ENVIRONMENT

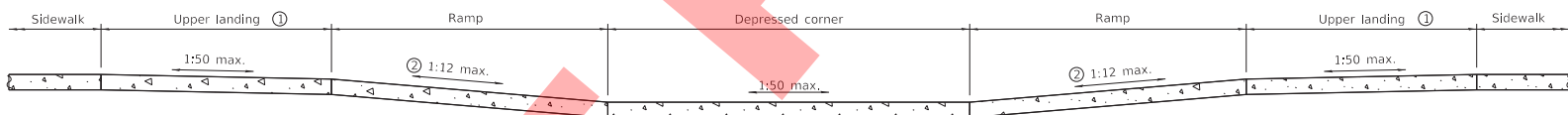
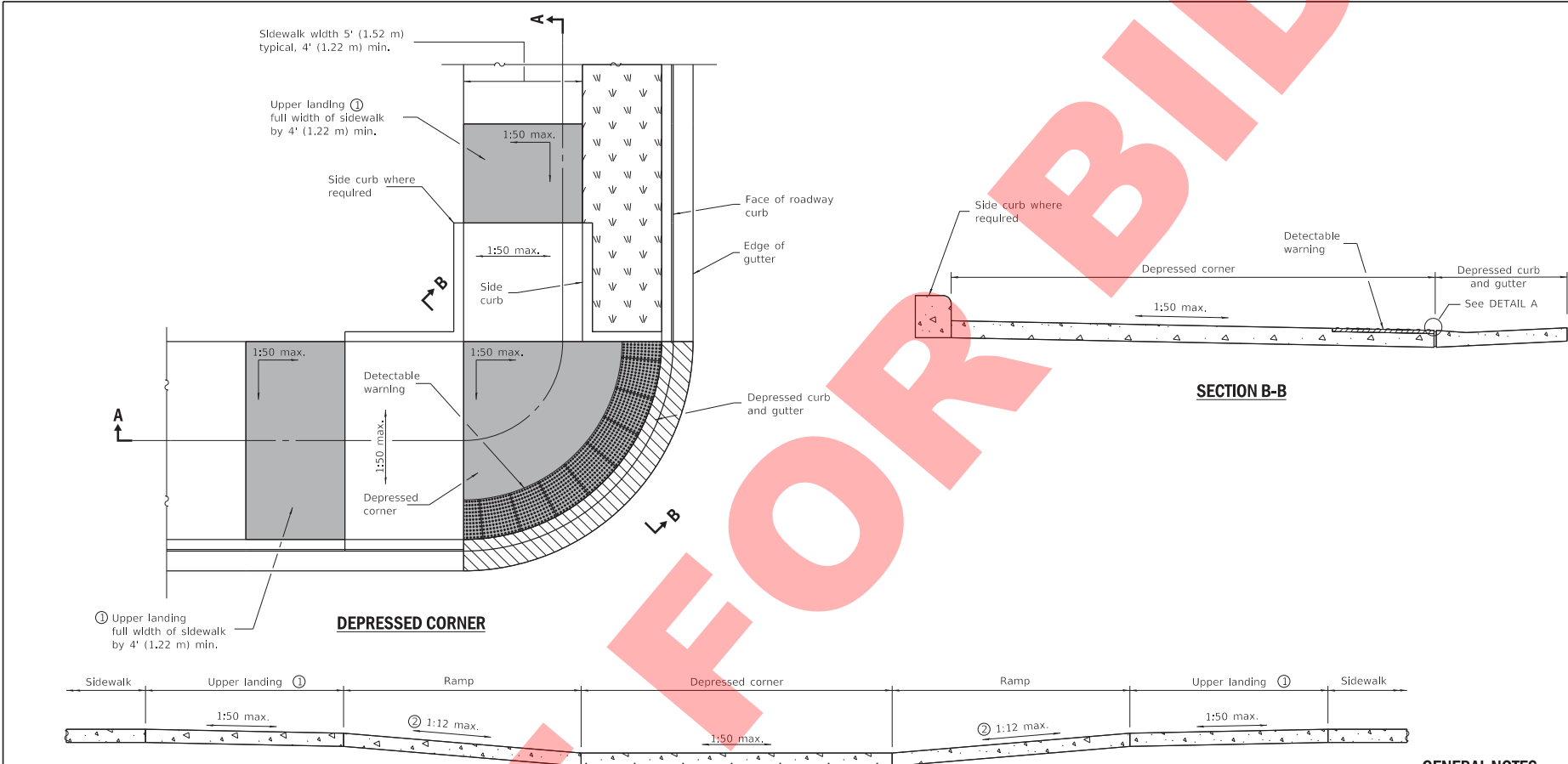

SECTION A-A

- ① Upper landing(s) not required for ramp slopes flatter than 1:20.
- ② The running slope of the curb ramp shall not require the ramp length to exceed 15' (4.5 m).

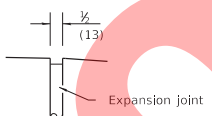

DETAIL A

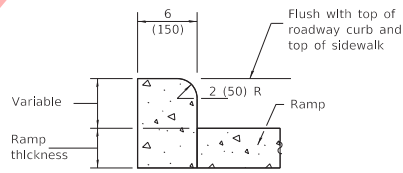

SIDE CURB DETAIL

GENERAL NOTES

This standard shall only be used for curb radii of 6 ft. (1.83 m) or greater.

All slope ratios are expressed as units of vertical displacement to units of horizontal displacement (V:H).

Where 1:50 maximum slope is shown, 1:64 is preferred.

See Standard 606001 for details of depressed curb adjacent to curb ramp.

All dimensions are in inches (millimeters) unless otherwise shown.

DATE	REVISIONS
1-1-18	Omitted diagonal slope at turning spaces and upper landings.
1-1-15	Added note ②.

DEPRESSED CORNER FOR SIDEWALKS

STANDARD 424021-04

Illinois Department of Transportation

PASSED January 1, 2018
Michael Beard
 ENGINEER OF POLICY AND PROCEDURES

APPROVED January 1, 2018
Maureen M. Behr
 ENGINEER OF DESIGN AND ENVIRONMENT

DESIGNED 1-1-17

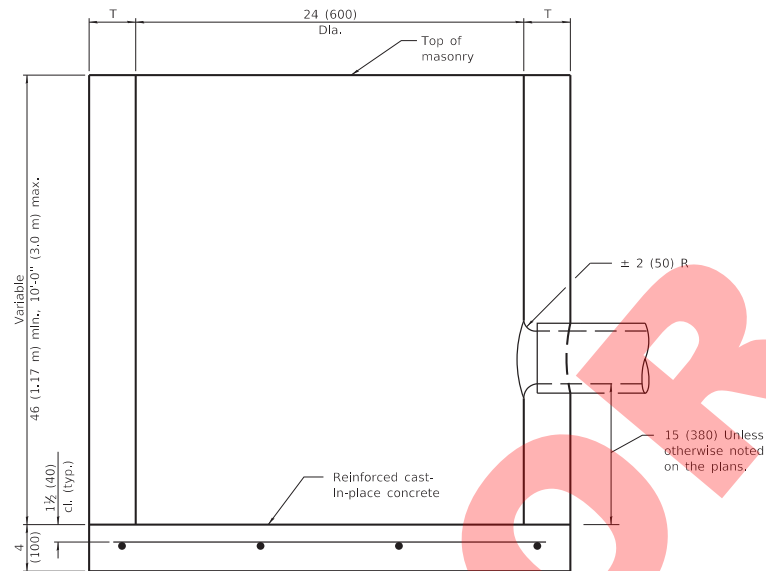

ALTERNATE MATERIALS FOR WALLS	T (min)
Precast Reinforced Concrete Section	3 (75)
Concrete Masonry Unit	5 (125)
Cast-in-Place Concrete	6 (150)
Brick Masonry	8 (200)

ELEVATION

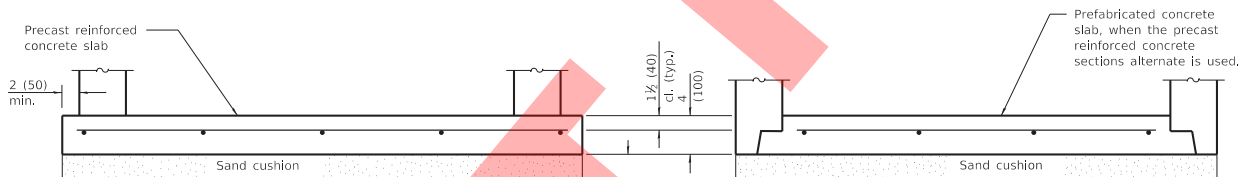

ALTERNATE BOTTOM SLAB

GENERAL NOTES

Bottom slabs shall be reinforced with a minimum of 0.27 sq. in./ft. (570 sq. mm/m) in both directions with a maximum spacing of 9 (230).

Bottom slabs may be connected to the riser as determined by the fabricator; however, only a single row of reinforcement around the perimeter may be utilized.

All dimensions are in inches (millimeters) unless otherwise shown.

Illinois Department of Transportation

PASSED January 1, 2011
Michael Beard
 ENGINEER OF POLICY AND PROCEDURES

APPROVED January 1, 2011
Spencer
 ENGINEER OF DESIGN AND ENVIRONMENT

DATE	REVISIONS
1-1-11	Detailed rein. in slabs.
	Added max. limit to height.
	Added general notes.
1-1-09	Switched units to
	English (metric).

CATCH BASIN TYPE C

STANDARD 602011-02

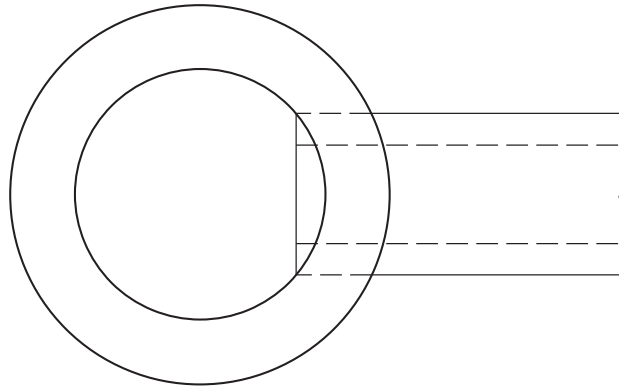

PLAN

ALTERNATE MATERIALS FOR WALLS	T
BRICK MASONRY	8 (200)
CAST-IN-PLACE CONCRETE	6 (150)
CONCRETE MASONRY UNIT	5 (125)
PRECAST REINFORCED CONCRETE SECTION	3 (75)

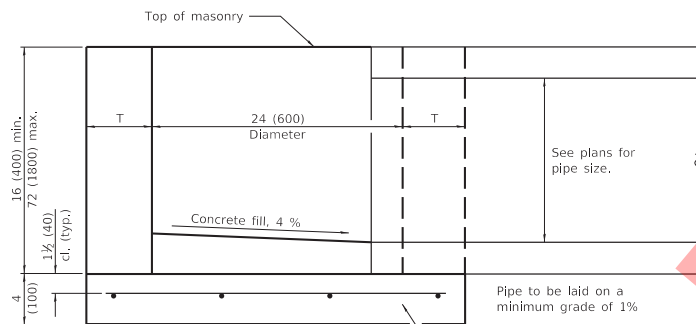

ELEVATION

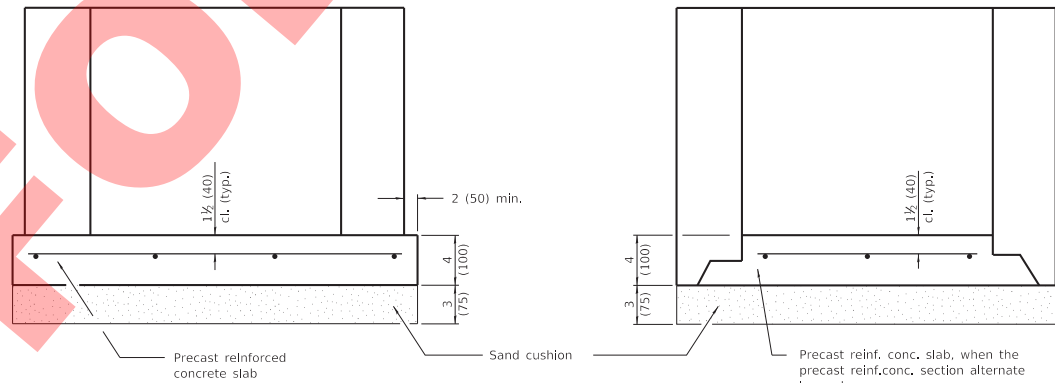

ALTERNATE METHODS

GENERAL NOTES

Bottom slabs shall be reinforced with a minimum of 0.24 sq. in./ft. (510 sq. mm/m) in both directions with a maximum spacing of 10 (250).

Bottom slabs may be connected to the riser as determined by the fabricator; however, only a single row of reinforcement around the perimeter may be utilized.

All dimensions are in inches (millimeters) unless otherwise shown.

DATE	REVISIONS
1-1-14	Increased height to 72 (1800) maximum.
1-1-11	Detailed rein. in slabs.
	Added max. limit to height.
	Added general notes.

INLET - TYPE A

STANDARD 602301-04

Illinois Department of Transportation

PASSED January 1, 2014
Michael Beard
 ENGINEER OF POLICY AND PROCEDURES

APPROVED January 1, 2014
[Signature]
 ENGINEER OF DESIGN AND ENVIRONMENT

4-SP-1 (REVISED)

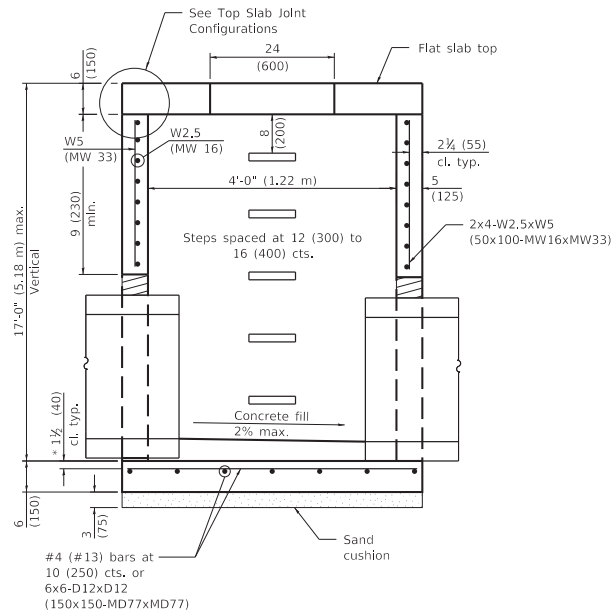

SECTION THRU MANHOLE
(With flat slab top only)

* Typical for top and bottom slabs.

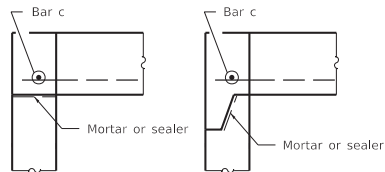

TOP SLAB JOINT CONFIGURATIONS
(Shown at access hole)

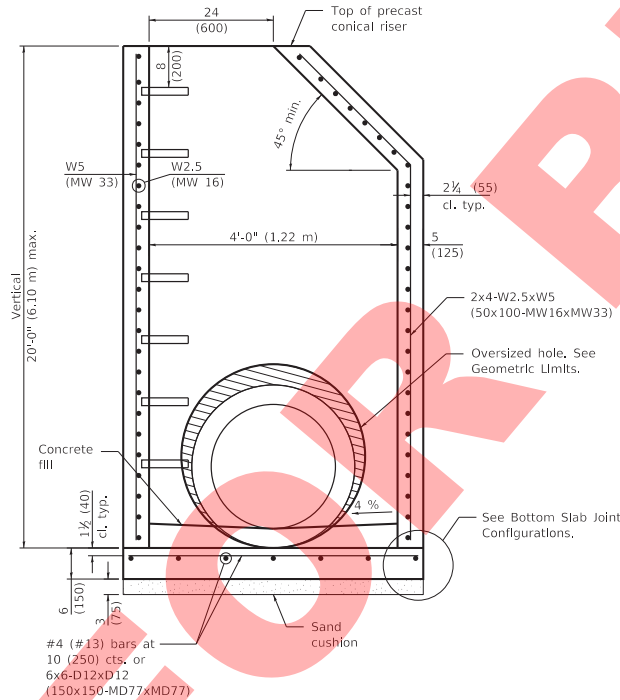

SECTION THRU MANHOLE
(With riser)

GEOMETRIC LIMITS

Oversized holes, as necessary for constructability, shall satisfy the following requirements:

1. A minimum of 9 (230) of monolithic reinforced concrete shall be maintained above the fabricated pipe hole.
2. A minimum 9 (230) inside arc length of reinforced concrete, extending vertically from bottom slab to top slab, shall be maintained between the fabricated pipe holes.
3. A maximum of 60 percent of the inside perimeter of the reinforced concrete manhole walls may be removed.
4. Horizontal joints through pipe holes shall be spliced when the remaining column between holes, measured along inside arc length, is less than 24 (600). See detail.
5. The recommended oversized hole is equal to the O.D. of the pipe plus 4 (100).

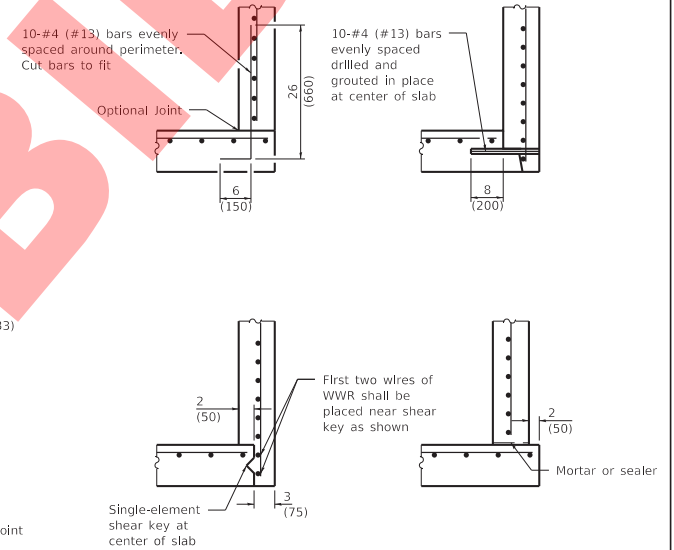

BOTTOM SLAB JOINT CONFIGURATIONS

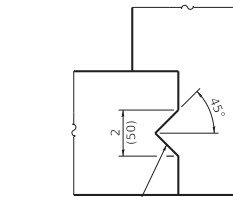

SHEAR KEY GEOMETRY
(Reinforcement not Shown for Clarity)

See Sheet 2 for General Notes.

DATE	REVISIONS
1-1-18	Completely revised std. for LRFD, Renamed std, Moved
	5' (1.5 m) manhole to new std.
1-1-11	Detailed rein. in slabs.
	Added max. limit to height.
	Revised general notes.

PRECAST MANHOLE TYPE A
4' (1.22 m) DIAMETER

(Sheet 1 of 2)

STANDARD 602401-04

Illinois Department of Transportation

PASSED January 1, 2018
Michael Beard
ENGINEER OF POLICY AND PROCEDURES

APPROVED January 1, 2018
Maurice M. Bello
ENGINEER OF DESIGN AND ENVIRONMENT

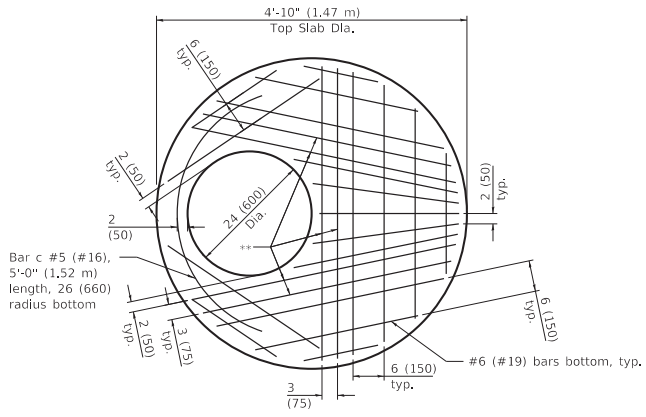

PLAN
(Showing Layout of Reinforcement Bars)

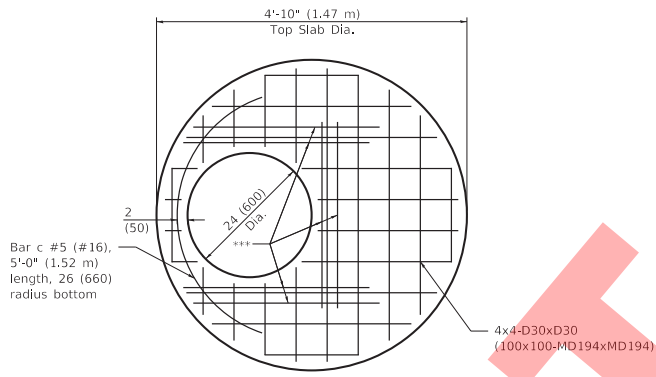

PLAN
(Showing Layout of Welded Wire Reinforcement)

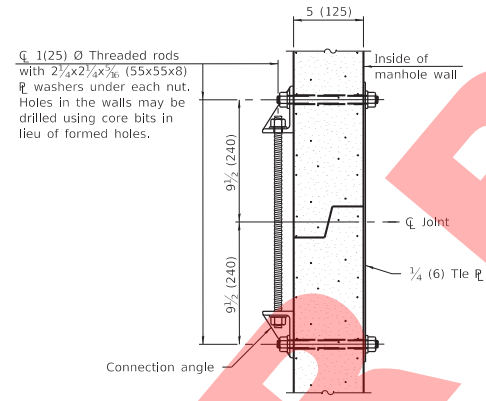

JOINT SPLICE

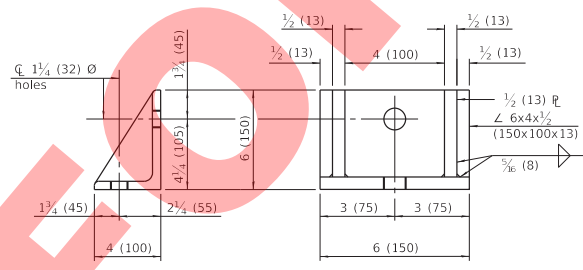

CONNECTION ANGLE

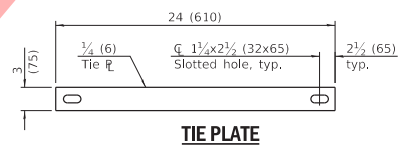

TIE PLATE

- ** #5 (#16) bars at 3 (75) cts. bottom.
- *** #5 (#16) bars at 3 (75) cts. 36 (910) long bottom. Bundle first bar with closest WWR bar to the opening.

GENERAL NOTES

Joint configuration and dimensions of flat slab shall match and fit the riser joint detail.

The manufacturer shall ensure that all precast manhole sections are additionally reinforced where required to resist damage from handling, shipping and installation stresses.

Lifting holes shall be located in the sections as per the manufacturer's recommendations and grouted prior to backfilling.

See Standard 602701 for details of manhole steps.

All dimensions are in inches (millimeters) unless otherwise noted.

**PRECAST MANHOLE TYPE A
4' (1.22 m) DIAMETER**
(Sheet 2 of 2)

STANDARD 602401-04

Illinois Department of Transportation

PASSED January 1, 2018

Michael Beard
ENGINEER OF POLICY AND PROCEDURES

APPROVED January 1, 2018

Matthew M. Behr
ENGINEER OF DESIGN AND ENVIRONMENT

DESIGNED

1-18-18

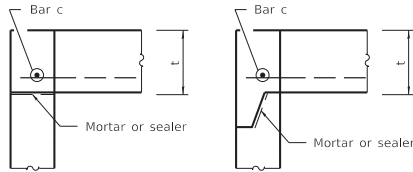

TOP SLAB JOINT CONFIGURATIONS
FOR D = 36 (900) AND D = 4'-0" (1.22 m)

(Shown at access hole)

See Top Slab Joint Configurations for D=36 (900) and D=4'-0" (1.22 m)

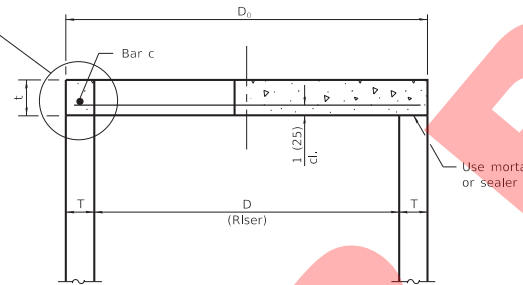

TOP SECTION THRU INLET OR CATCH BASIN
FOR D = 36 (900) AND D = 4'-0" (1.22 m)

Bar c #4 (#13), 4'-0" (1.22 m) length, 19 1/2 (495) radius bottom

Use mortar or sealer

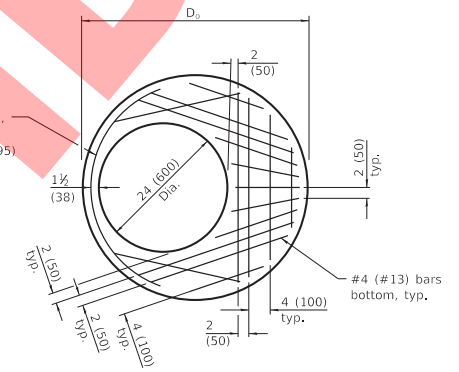

PLAN FOR D = 36 (900)

(Showing Layout of Reinforcement Bars)

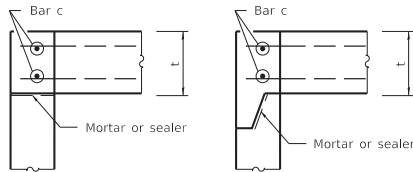

TOP SLAB JOINT CONFIGURATIONS
D = 5'-0" (1.52 m)

(Shown at access hole)

See Top Slab Joint Configurations for D=5'-0" (1.52 m)

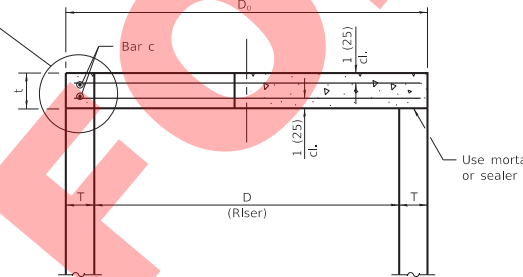

TOP SECTION THRU CATCH BASIN
FOR D = 5'-0" (1.52 m)

Bar c #4 (#13), 4'-0" (1.22 m) length, 19 1/2 (495) radius bottom

Use mortar or sealer

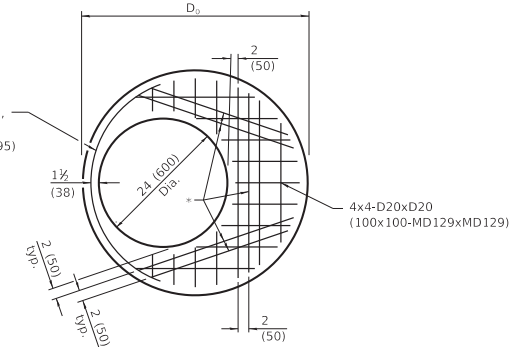

PLAN FOR D = 36 (900)

(Showing Layout of Welded Wire Reinforcement)

* #4 (#13) bars bottom. Bundle first bar with WWR bar closest to the opening.

TABLE

D	T	D ₀ (min.)	t
36 (900)	See applicable Standards	D + 2T	6 (150)
4'-0" (1.2 m)		D + 2T	6 (150)
5'-0" (1.5 m)		D + 2T	8 (200)

GENERAL NOTES

The flat slab top may be used in lieu of the tapered tops shown on Standards 602001, 602016, or 602306 at the option of the Contractor or when field conditions prohibit the use of tapered tops.

Lifting holes shall be located in the sections as per the manufacturer's recommendations and grouted prior to backfilling.

All dimensions are in inches (millimeters) unless otherwise shown.

DATE	REVISIONS
1-1-18	Revised for compliance with LRFD.
4-1-16	Changed terminology to 'welded wire reinforcement'.

PRECAST REINFORCED CONCRETE FLAT SLAB TOP
 (Sheet 1 of 2)

STANDARD 602601-05

Illinois Department of Transportation

PASSED January 1, 2018
Michael Beard
 ENGINEER OF POLICY AND PROCEDURES

APPROVED January 1, 2018
Maureen M. Behr
 ENGINEER OF DESIGN AND ENVIRONMENT

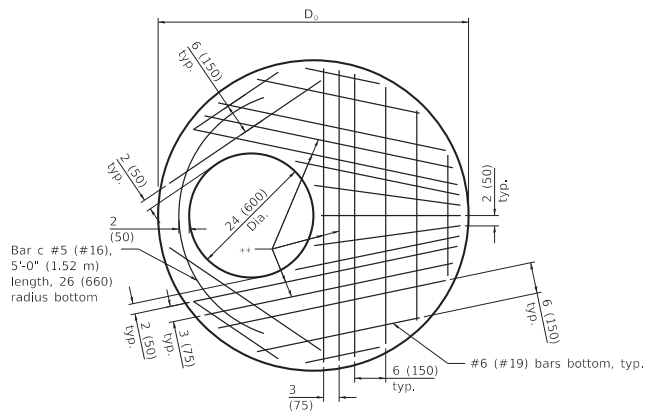

PLAN FOR D = 4'-0" (1.22 m)
(Showing Layout of Reinforcement Bars)

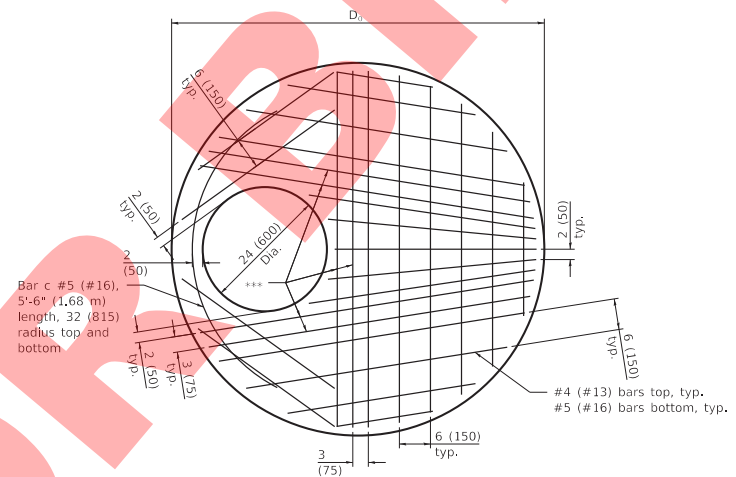

PLAN FOR D = 5'-0" (1.52 m)
(Showing Layout of Reinforcement Bars)

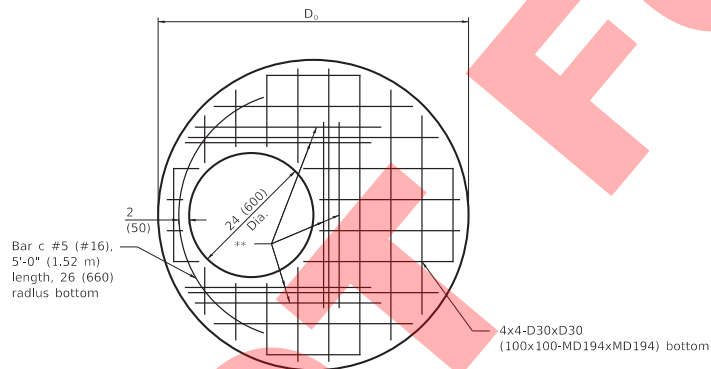

PLAN FOR D = 4'-0" (1.22 m)
(Showing Layout of Welded Wire Reinforcement)

** #5 (#16) bars bottom. For WWR, bundle first bar with WWR bar closest to the opening.

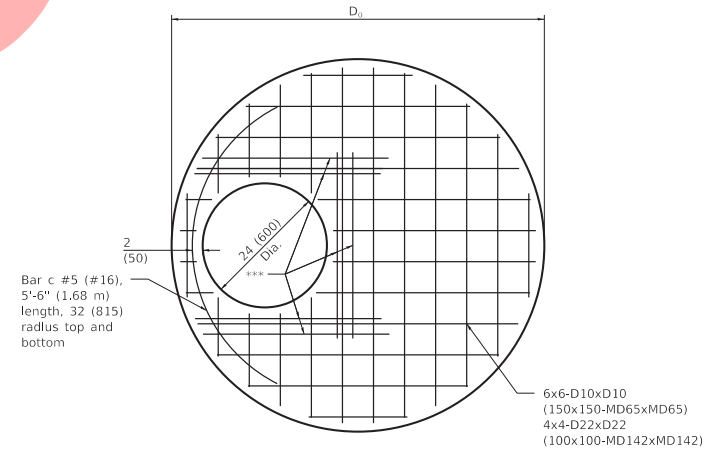

PLAN FOR D = 5'-0" (1.52 m)
(Showing Layout of Welded Wire Reinforcement)

*** #5 (#16) bars top and bottom. For WWR, bundle first bar with WWR bar closest to the opening.

Illinois Department of Transportation	
PASSED	January 1, 2018
<i>Michael Beard</i>	
ENGINEER OF POLICY AND PROCEDURES	
APPROVED	January 1, 2018
<i>Maureen M. Behr</i>	
ENGINEER OF DESIGN AND ENVIRONMENT	

PRECAST REINFORCED CONCRETE FLAT SLAB TOP (Sheet 2 of 2)
STANDARD 602601-05

CAST IRON STEPS

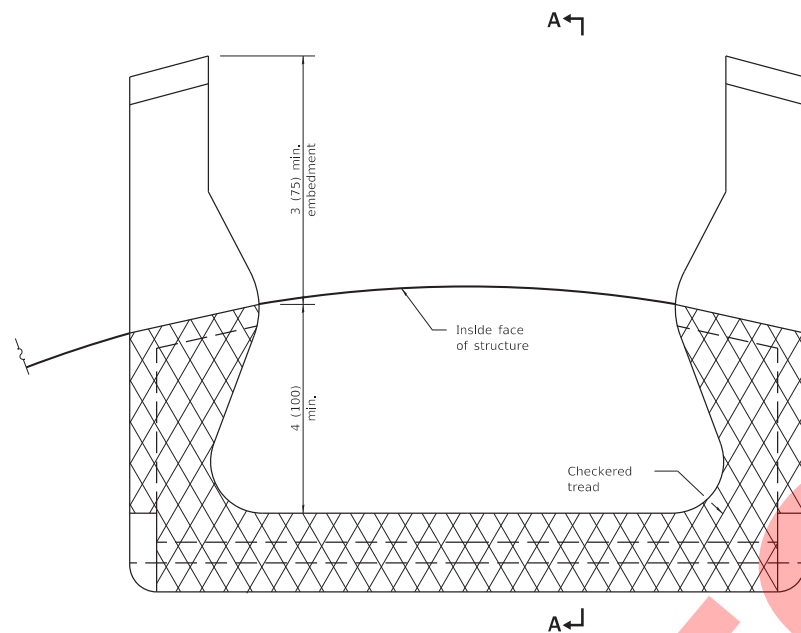

PLAN VIEW

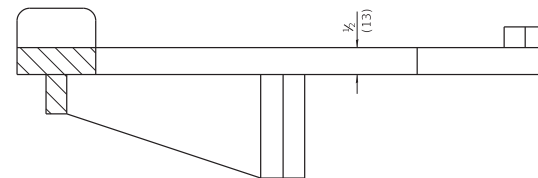

SECTION A-A

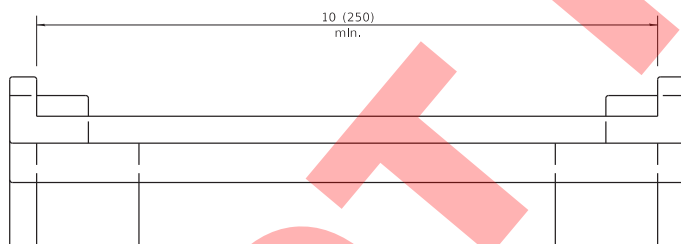

ELEVATION VIEW

All dimensions are in inches (millimeters) unless otherwise shown.

Illinois Department of Transportation	
PASSED	January 1, 2009
ENGINEER OF POLICY AND PROCEDURES	
APPROVED	January 1, 2009
ENGINEER OF DESIGN AND ENVIRONMENT	

DATE	REVISIONS
1-1-09	Switched units to English (metric).
4-1-06	Revised title, drawings, and added plastic steps on sheet 2.

MANHOLE STEPS

(Sheet 1 of 2)

STANDARD 602701-02

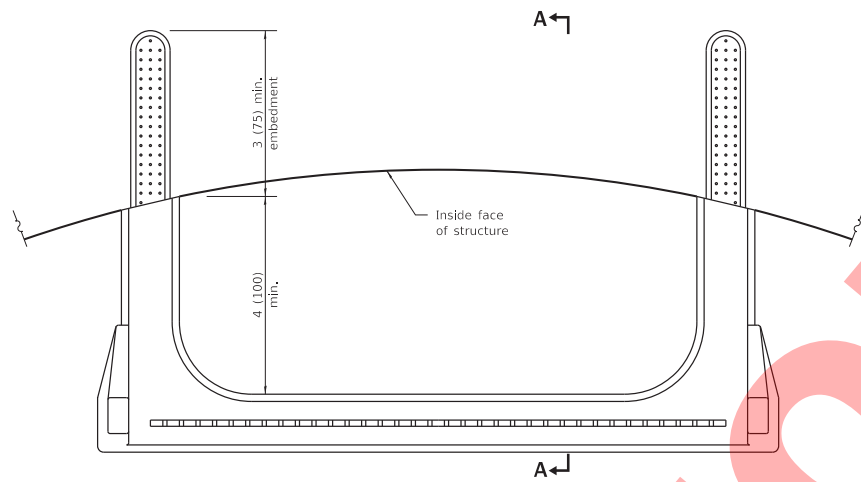

PLAN VIEW

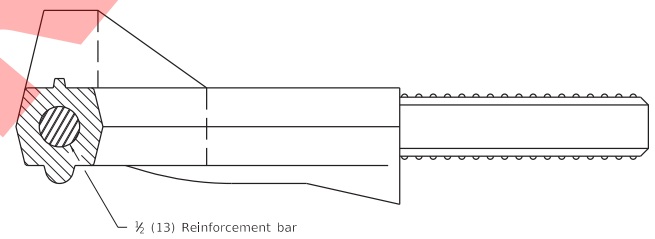

SECTION A-A

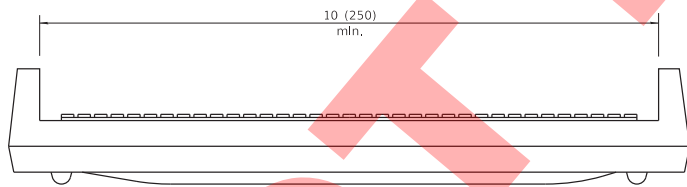

ELEVATION VIEW

	Illinois Department of Transportation
PASSED	January 1, 2009
ENGINEER OF POLICY AND PROCEDURES	<i>[Signature]</i>
APPROVED	January 1, 2009
ENGINEER OF DESIGN AND ENVIRONMENT	<i>[Signature]</i>

MANHOLE STEPS
(Sheet 2 of 2)
STANDARD 602701-02

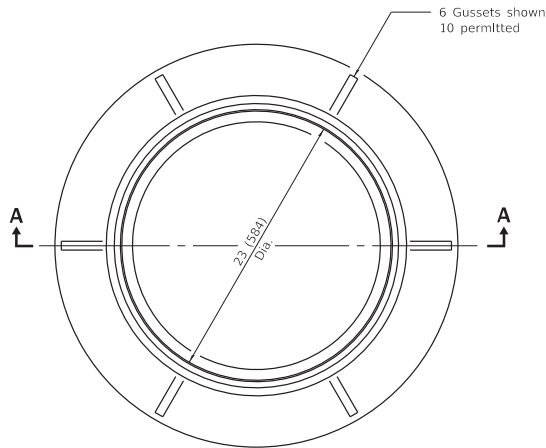

CAST FRAME

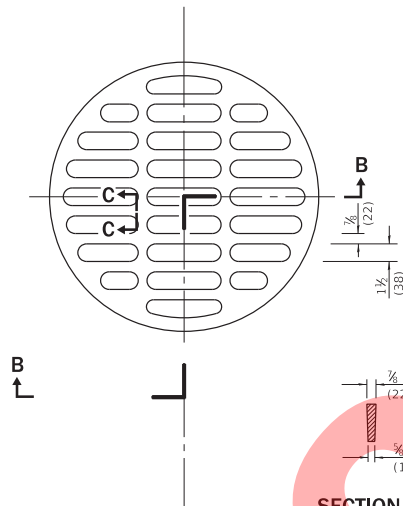

SECTION C-C

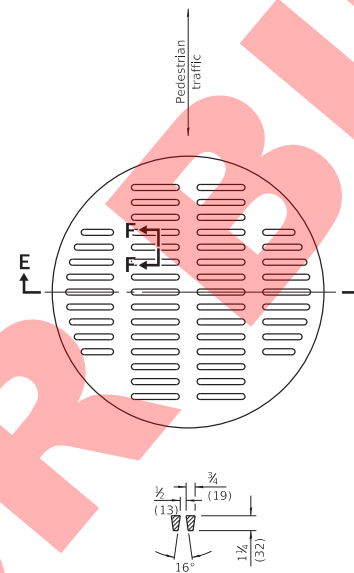

SECTION F-F

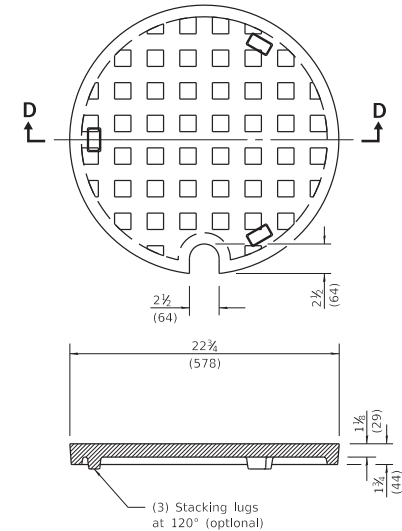

SECTION D-D

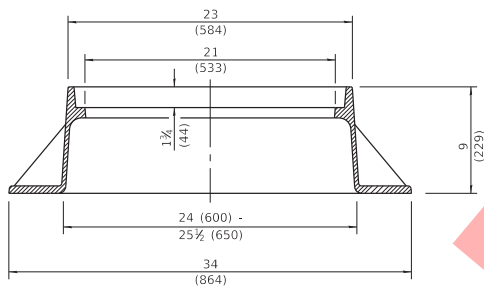

SECTION A-A
Gray Iron

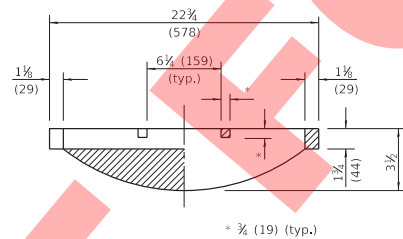

SECTION B-B

CAST OPEN LID

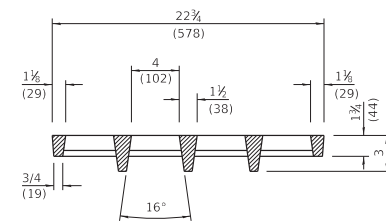

SECTION E-E

**ADA COMPLIANT
CAST OPEN LID**

CAST CLOSED LID
Gray Iron Lid

All dimensions are in inches (millimeters) unless otherwise shown.

Illinois Department of Transportation	
PASSED	January 1, 2015
<i>Michael Beard</i>	
ENGINEER OF POLICY AND PROCEDURES	
APPROVED:	January 1, 2015
<i>[Signature]</i>	
ENGINEER OF DESIGN AND ENVIRONMENT	

DATE	REVISIONS
1-1-15	Revised dimensioning of frame. Added ADA compliant open lid.
1-1-09	Switched units to English (metric).

**FRAME AND LIDS
TYPE 1**

STANDARD 604001-04

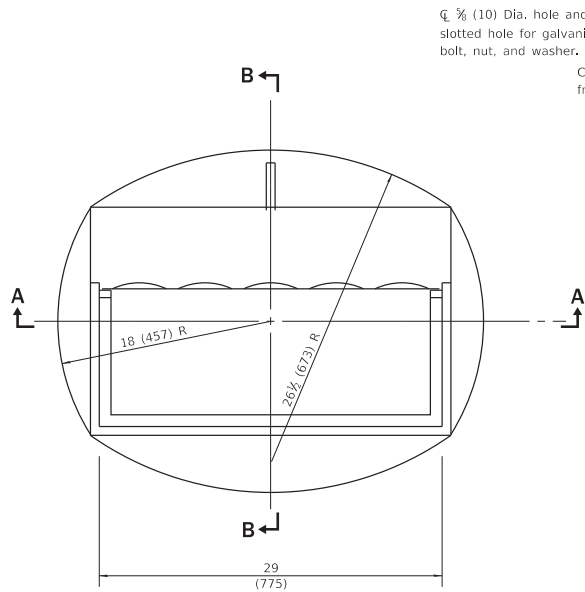

CAST FRAME

☉ 5/8 (10) Dia. hole and 5/8x5 1/2 (16x140) slotted hole for galvanized 1/2 (M12) bolt, nut, and washer.

Curb box adjustable from 4 1/2 (115) to 9 (225)

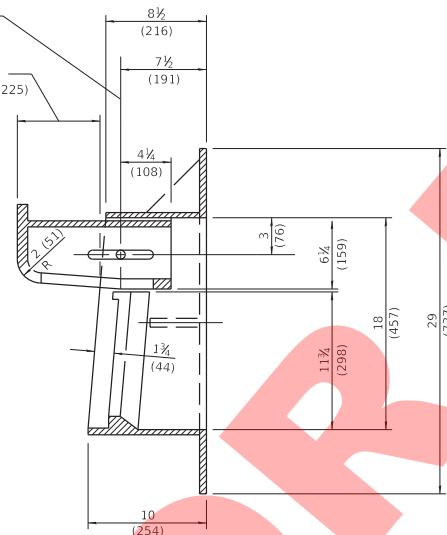

SECTION B-B

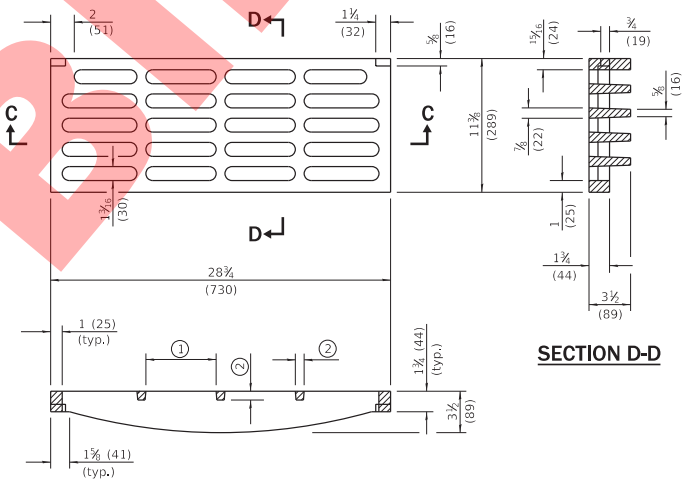

SECTION C-C

SECTION D-D

- ① = 6 1/2 (159) max. (typ.)
- ② = 3/4 (19) min. (typ.)

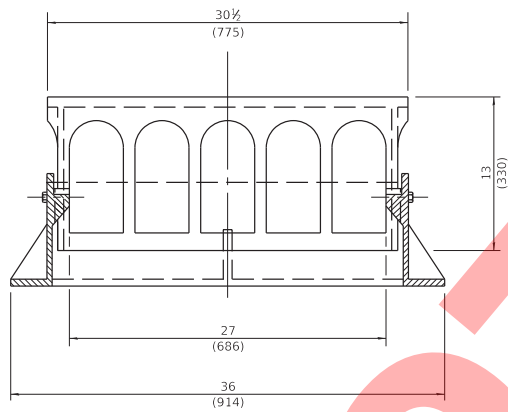

SECTION A-A

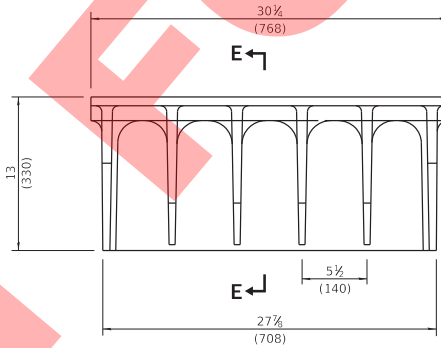

ALTERNATE CURB BOX

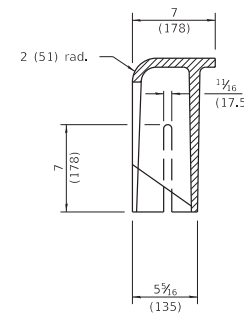

SECTION E-E

CAST GRATE

All dimensions are in inches (millimeters) unless otherwise shown.

Illinois Department of Transportation	
PASSED	January 1, 2015
<i>Michael Beard</i>	
ENGINEER OF POLICY AND PROCEDURES	
APPROVED	January 1, 2015
<i>CR</i>	
ENGINEER OF DESIGN AND ENVIRONMENT	

DATE	REVISIONS
1-1-15	Revised dimensions of frame and alternate curb box.
4-1-09	Switched units to English (metric).

**FRAME AND GRATE
TYPE 11**

STANDARD 604051-04

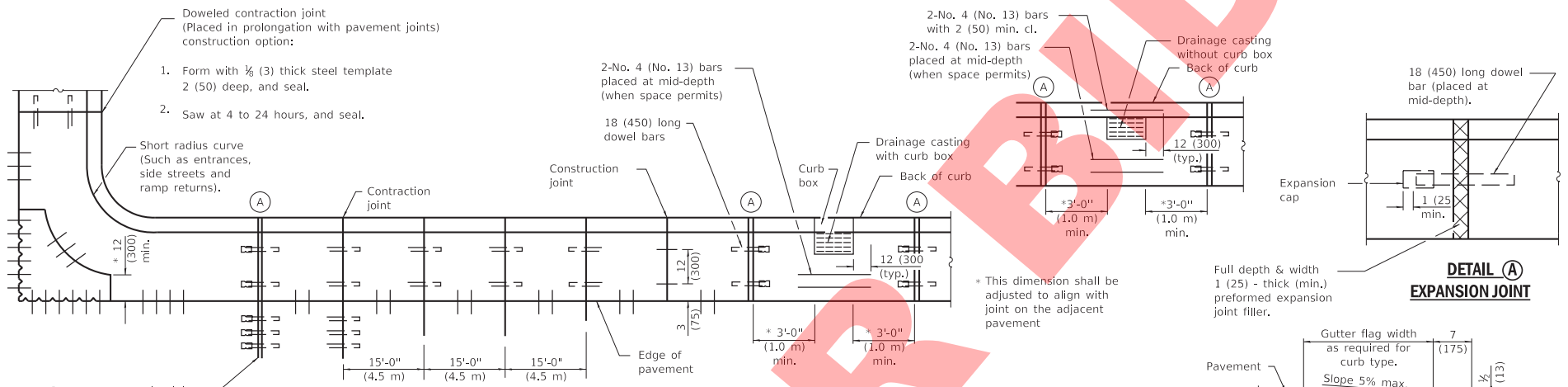

PLAN
ADJACENT TO PCC PAVEMENT OR PCC BASE COURSE

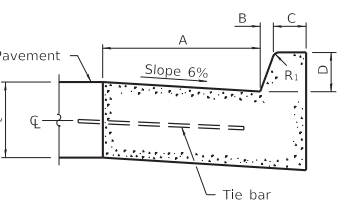

BARRIER CURB

TABLE OF DIMENSIONS BARRIER CURB						
TYPE	A	B	C	D	R ₁	
B-6.06 *	6	1	6	6	1	
(B-15.15)	(150)	(25)	(150)	(150)	(25)	
B-6.12	12	1	6	6	1	
(B-15.3)	(300)	(25)	(150)	(150)	(25)	
B-6.18	18	1	6	6	1	
(B-15.45)	(450)	(25)	(150)	(150)	(25)	
B-6.24	24	1	6	6	1	
(B-15.60)	(600)	(25)	(150)	(150)	(25)	
B-9.12	12	2	5	9	1	
(B-22.30)	(300)	(50)	(125)	(225)	(25)	
B-9.18	18	2	5	9	1	
(B-22.45)	(450)	(50)	(125)	(225)	(25)	
B-9.24	24	2	5	9	1	
(B-22.60)	(600)	(50)	(125)	(225)	(25)	

* For corner islands only.

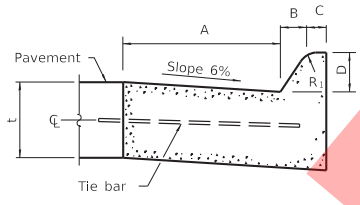

MOUNTABLE CURB

TABLE OF DIMENSIONS MOUNTABLE CURB							
TYPE	A	B	C	D	R ₁	R ₂	
M-2.06	6	2	4	2	3	2	
(M-5.15)	(150)	(50)	(100)	(50)	(75)	(50)	
M-2.12	12	2	4	2	3	2	
(M-5.30)	(300)	(50)	(100)	(50)	(75)	(50)	
M-4.06	6	4	3	4	3	NA	
(M-10.15)	(150)	(100)	(75)	(100)	(75)	NA	
M-4.12	12	4	3	4	3	NA	
(M-10.30)	(300)	(100)	(75)	(100)	(75)	NA	
M-4.18	18	4	3	4	3	NA	
(M-10.45)	(450)	(100)	(75)	(100)	(75)	NA	
M-4.24	24	4	3	4	3	NA	
(M-10.60)	(600)	(100)	(75)	(100)	(75)	NA	
M-6.06	6	6	2	6	2	NA	
(M-15.15)	(150)	(150)	(50)	(150)	(50)	NA	
M-6.12	12	6	2	6	2	NA	
(M-15.30)	(300)	(150)	(50)	(150)	(50)	NA	
M-6.18	18	6	2	6	2	NA	
(M-15.45)	(450)	(150)	(50)	(150)	(50)	NA	
M-6.24	24	6	2	6	2	NA	
(M-15.60)	(600)	(150)	(50)	(150)	(50)	NA	

**ADJACENT TO PCC BASE COURSE
WITH HMA SURFACING**

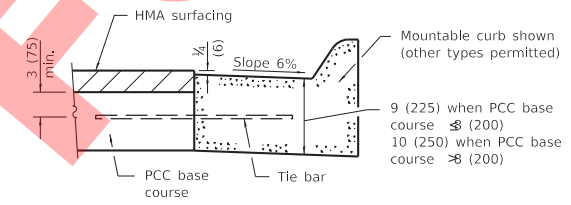

M-2.06 (M-5.15) and M-2.12 (M-5.30)

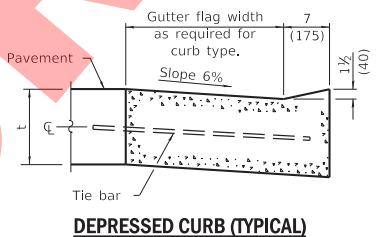

DEPRESSED CURB (TYPICAL)

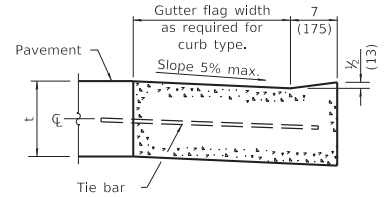

**DEPRESSED CURB ADJACENT
TO CURB RAMP ACCESSIBLE
TO THE DISABLED**

GENERAL NOTES

The bottom slope of combination curb and gutter constructed adjacent to pcc pavement shall be the same slope as the subbase or 6% when subbase is omitted.

t = Thickness of pavement.

Longitudinal joint tie bars shall be No. 6 (No. 19) at 36 (900) centers in accordance with details for longitudinal construction joint shown on Standard 420001.

A minimum clearance of 2 (50) between the end of the tie bar and the back of the curb shall be maintained.

The dowel bars shown in contraction joints will only be required for monolithic construction.

See Standard 606301 for details of corner islands.

All dimensions are in inches (millimeters) unless otherwise shown.

DATE	REVISIONS
1-1-18	Revised General Note for tie bar spacing to 36 (900) cts.
1-1-15	Added B-6.06 (B-15.15) barrier curb and gutter to table (corner islands only).

**CONCRETE CURB TYPE B
AND COMBINATION
CONCRETE CURB AND GUTTER**
(Sheet 1 of 2)

STANDARD 606001-07

Illinois Department of Transportation

PASSED January 1, 2018

Michael Beard
ENGINEER OF POLICY AND PROCEDURES

APPROVED January 1, 2018

Matthew M. Peltz
ENGINEER OF DESIGN AND ENVIRONMENT

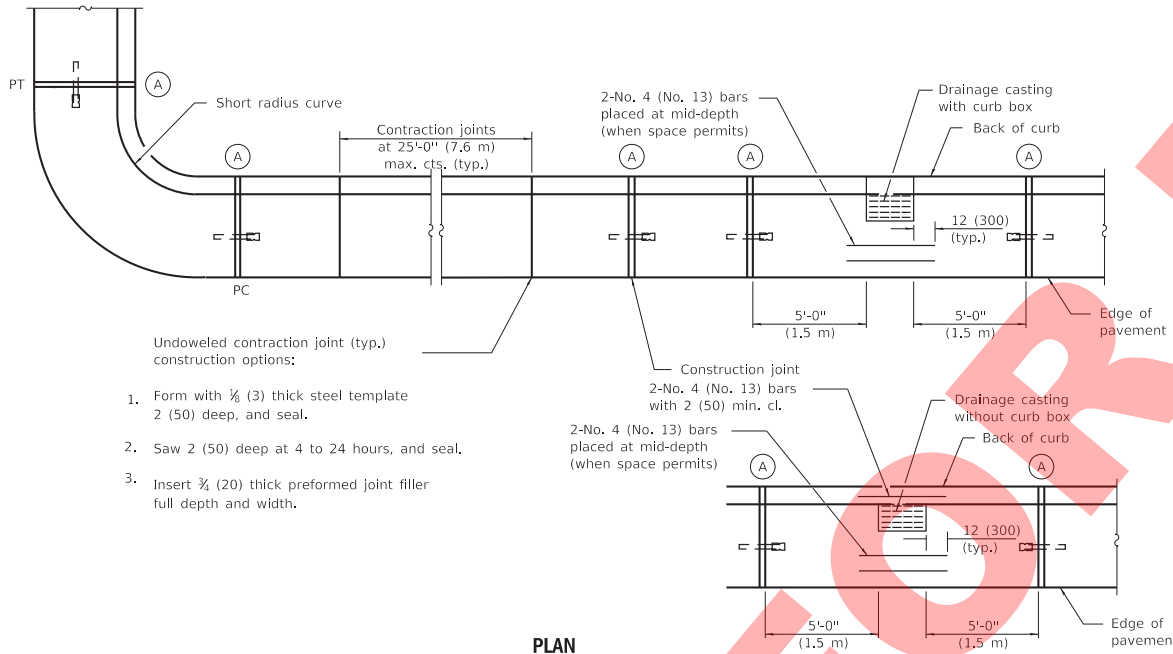

Undoweled contraction joint (typ.) construction options:

1. Form with $\frac{3}{8}$ (3) thick steel template 2 (50) deep, and seal.
2. Saw 2 (50) deep at 4 to 24 hours, and seal.
3. Insert $\frac{3}{4}$ (20) thick preformed joint filler full depth and width.

PLAN

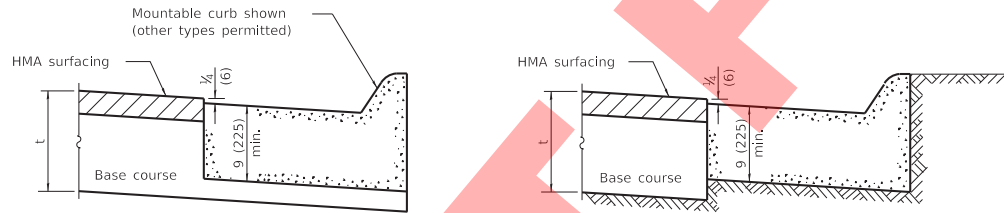

ON DISTURBED SUBGRADE

ON UNDISTURBED SUBGRADE

ADJACENT TO FLEXIBLE PAVEMENT

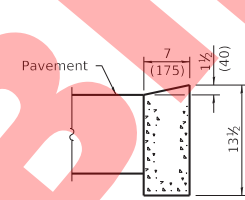

DEPRESSED CURB

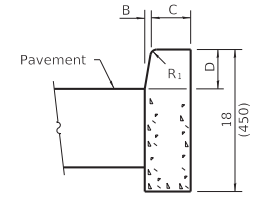

BARRIER CURB

ADJACENT TO FLEXIBLE PAVEMENT

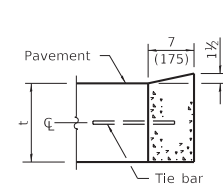

DEPRESSED CURB

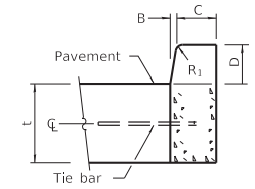

BARRIER CURB

ADJACENT TO PCC PAVEMENT OR PCC BASE COURSE

CONCRETE CURB TYPE B

**CONCRETE CURB TYPE B
AND COMBINATION
CONCRETE CURB AND GUTTER**

(Sheet 2 of 2)

STANDARD 606001-07

Illinois Department of Transportation

PASSED January 1, 2018
Michael Beard
ENGINEER OF POLICY AND PROCEDURES

APPROVED January 1, 2018
Maureen M. Bels
ENGINEER OF DESIGN AND ENVIRONMENT

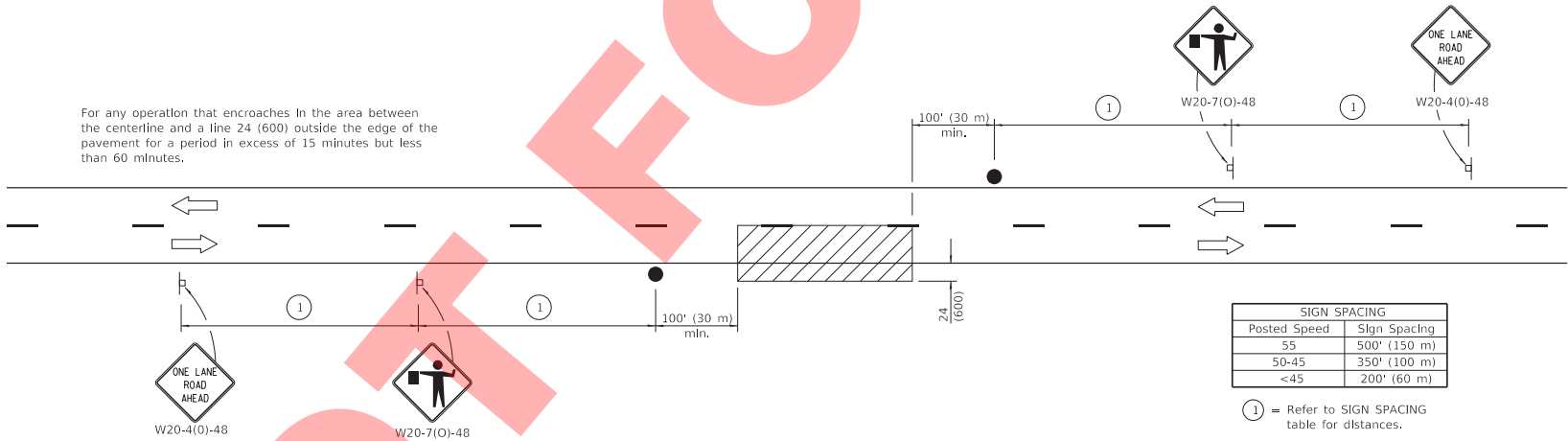
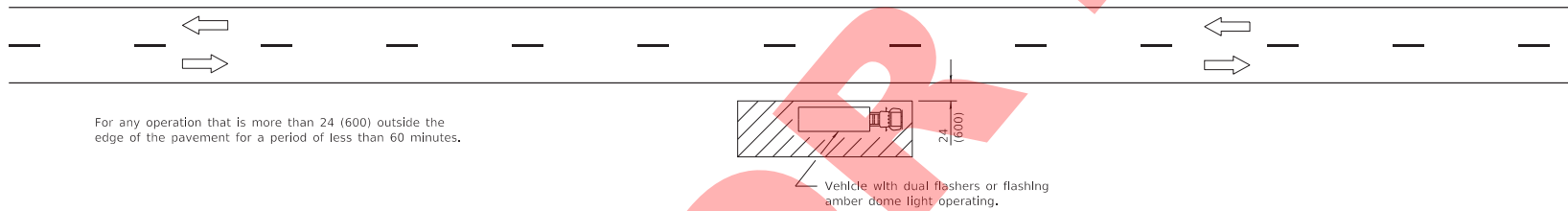
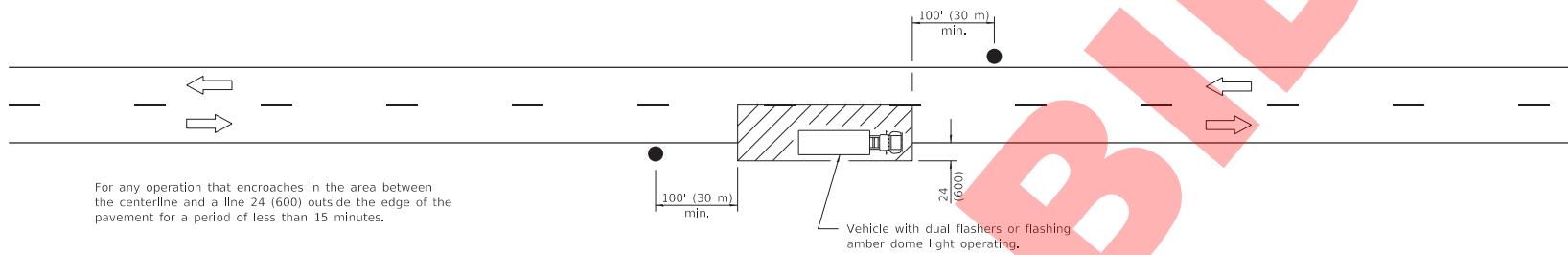

SIGN SPACING	
Posted Speed	Sign Spacing
55	500' (150 m)
50-45	350' (100 m)
<45	200' (60 m)

TYPICAL APPLICATIONS

- Marking patches
- Field survey
- String line
- Utility operations
- Cleaning up debris on pavement

SYMBOLS

- Work area
- Sign on portable or permanent support
- Flagger with traffic control sign

All dimensions are in inches (millimeters) unless otherwise shown.

Illinois Department of Transportation

PASSED January 1, 2011
Amber Adams
 ENGINEER OF SAFETY ENGINEERING

APPROVED January 1, 2011
Scott
 ENGINEER OF DESIGN AND ENVIRONMENT

4-10-11 (REVISED)

DATE	REVISIONS
1-1-11	Revised flagger sign.
1-1-09	Switched units to English (metric).

LANE CLOSURE, 2L, 2W, SHORT TIME OPERATIONS

STANDARD 701301-04

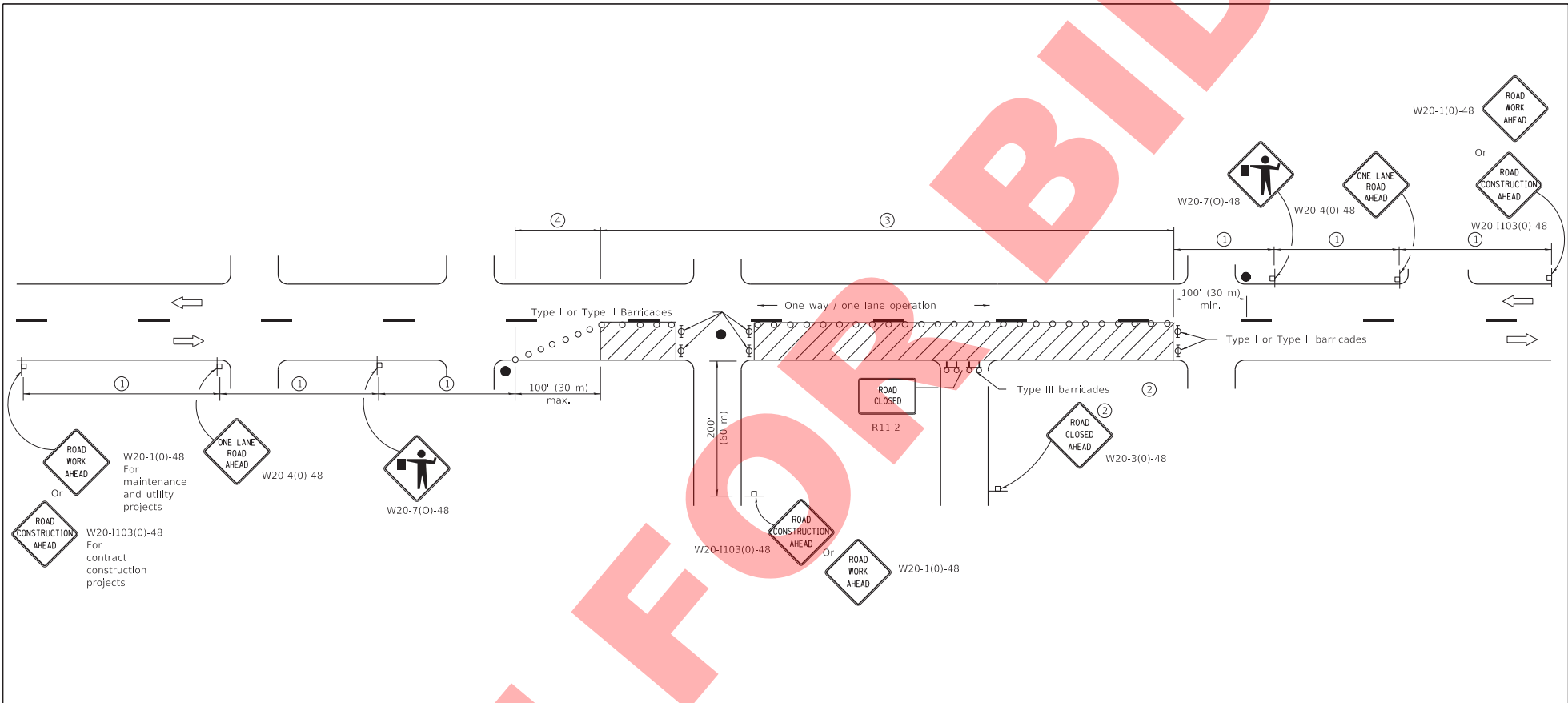

SIGN SPACING	
Posted Speed	Sign Spacing
55	500' (150 m)
50-45	350' (100 m)
<45	200' (60 m)

SYMBOLS

- Work area
- Cone, drum or barricade (not required for moving operations)
- Sign on portable or permanent support
- Flagger with traffic control sign
- Barricade or drum with flashing light
- Type III barricade with flashing lights

- ① Refer to SIGN SPACING TABLE for distances.
- ② For approved sideroad closures.
- ③ Cones at 25' (8 m) centers for 250' (75 m). Additional cones may be placed at 50' (15 m) centers. When drums or Type I or Type II barricades are used, the interval between devices may be doubled.
- ④ Cones, drums or barricades at 20' (6 m) centers.

GENERAL NOTES

This Standard is used where at any time, day or night, any vehicle, equipment, workers or their activities encroach on the pavement requiring the closure of one traffic lane in an urban area.

All dimensions are in inches (millimeters) unless otherwise shown.

Illinois Department of Transportation

PASSED January 1, 2011
 ENGINEER OF SAFETY ENGINEERING

APPROVED January 1, 2011
 ENGINEER OF DESIGN AND ENVIRONMENT

DATE	REVISIONS
1-1-11	Revised flagger sign.
1-1-09	Switched units to English (metric).
	Corrected sign No.'s.

URBAN LANE CLOSURE, 2L, 2W, UNDIVIDED

STANDARD 701501-06

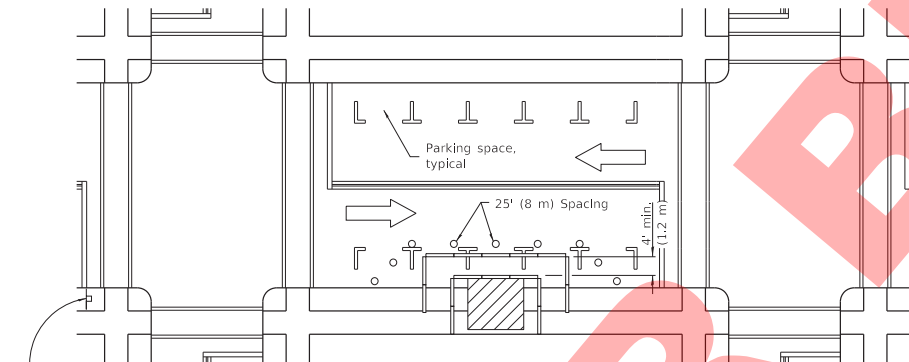

① ROAD CONSTRUCTION AHEAD
W20-1103(0)-48 for contract construction projects

Or

① ROAD WORK AHEAD
W20-1(0)-48 for maintenance and utility projects

SIDEWALK DIVERSION

① Omit whenever duplicated by road work traffic control.

SYMBOLS

- Work area
- Sign on portable or permanent support
- Barricade or drum
- Cone, drum or barricade
- Type III barricade
- Detectable pedestrian channelizing barricade

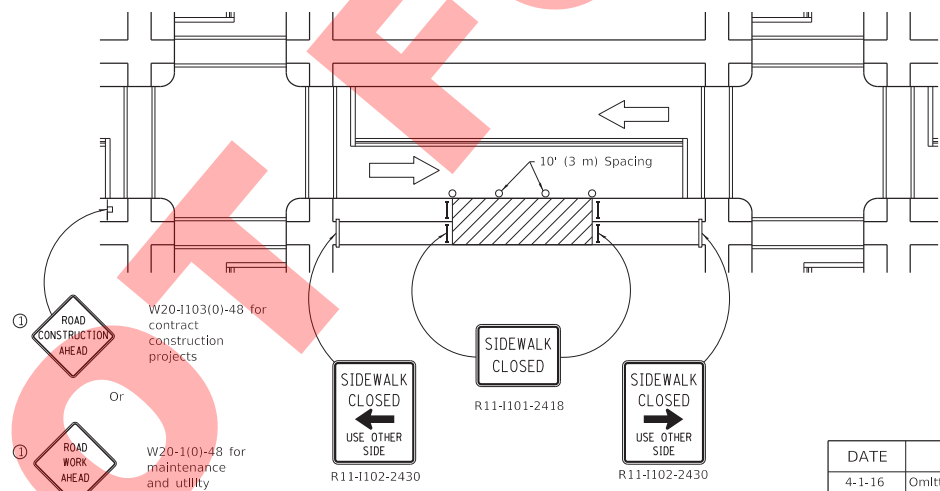

① ROAD CONSTRUCTION AHEAD
W20-1103(0)-48 for contract construction projects

Or

① ROAD WORK AHEAD
W20-1(0)-48 for maintenance and utility projects

SIDEWALK CLOSED
R11-1101-2418

SIDEWALK CLOSED
USE OTHER SIDE
R11-1102-2430

SIDEWALK CLOSED
USE OTHER SIDE
R11-1102-2430

SIDEWALK CLOSURE

GENERAL NOTES

This Standard is used where, at any time, pedestrian traffic must be rerouted due to work being performed.

This Standard must be used in conjunction with other Traffic Control & Protection Standards when roadway traffic is affected.

Temporary facilities shall be detectable and accessible.

The temporary pedestrian facilities shall be provided on the same side of the closed facilities whenever possible.

The SIDEWALK CLOSED / USE OTHER SIDE sign shall be placed at the nearest crosswalk or intersection to each end of the closure. Where the closure occurs at a corner, the signs shall be erected on the corners across the street from the closure. The SIDEWALK CLOSED signs shall be used at the ends of the actual closures.

Type III barricades and R11-2-4830 signs shall be positioned as shown in "ROAD CLOSED TO ALL TRAFFIC" detail on Standard 701901.

All dimensions are in inches (millimeters) unless otherwise shown.

DATE	REVISIONS
4-1-16	Omitted orange safety fence from standard as this is covered in the std. spec.
1-1-12	Added SIDEWALK DIVERSION. Modified appearance of plan views. Renamed Std.

SIDEWALK, CORNER OR CROSSWALK CLOSURE

(Sheet 1 of 2)

STANDARD 701801-06

Illinois Department of Transportation

PASSED *[Signature]* April 1, 2016
ENGINEER OF SAFETY ENGINEERING

APPROVED *[Signature]* April 1, 2016
ENGINEER OF DESIGN AND ENVIRONMENT

152153

NOT FOR FIELD



R11-1102-2430



W20-1103(0)-48 for contract construction projects

Or



W20-1101(0)-48 for maintenance and utility projects

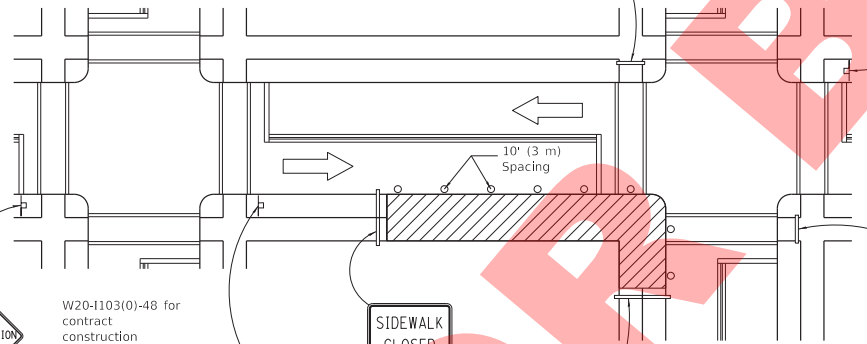

W20-1103(0)-48 for contract construction projects

Or



W20-1101(0)-48 for maintenance and utility projects



R11-1101-2418



R11-1101-2418



R11-1102-2430



R11-1102-2430

CORNER CLOSURE



R11-1102-2430



R11-1102-2430



R3-1-2424



R3-2-2424

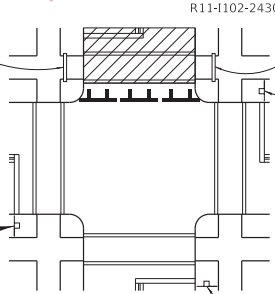

R20-3(0)-48

CROSSWALK CLOSURE

Illinois Department of Transportation

PASSED	April 1, 2016
APPROVED	April 1, 2016

ENGINEER OF SAFETY ENGINEERING
ENGINEER OF DESIGN AND ENVIRONMENT

SIDEWALK, CORNER OR CROSSWALK CLOSURE

(Sheet 2 of 2)

STANDARD 701801-06

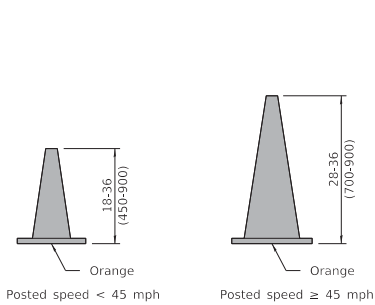

CONE FOR DAYTIME

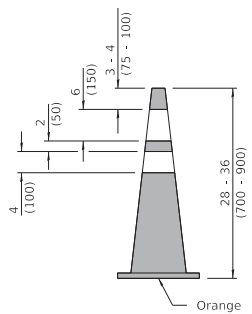

REFLECTORIZED CONE FOR NIGHTTIME

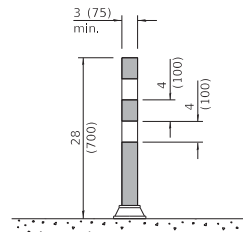

TUBULAR MARKER

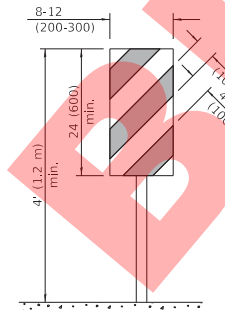

VERTICAL PANEL POST MOUNTED

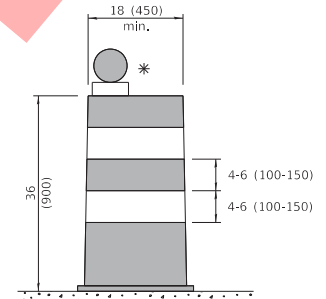

DRUM

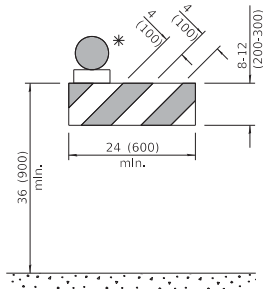

TYPE I BARRICADE

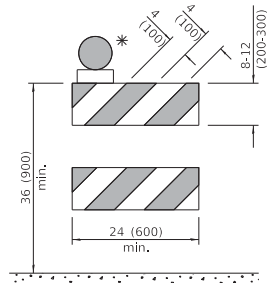

TYPE II BARRICADE

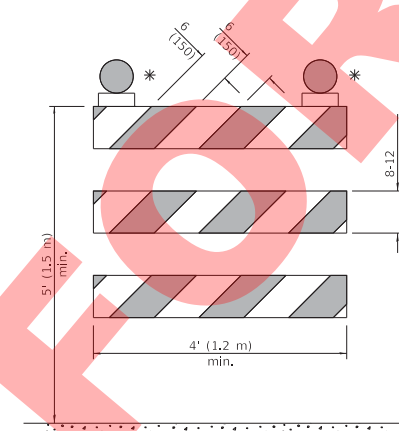

TYPE III BARRICADE

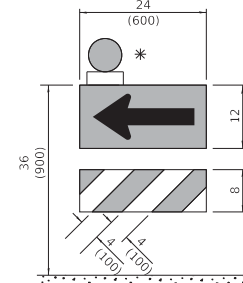

DIRECTION INDICATOR BARRICADE

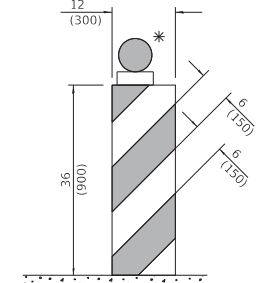

VERTICAL BARRICADE

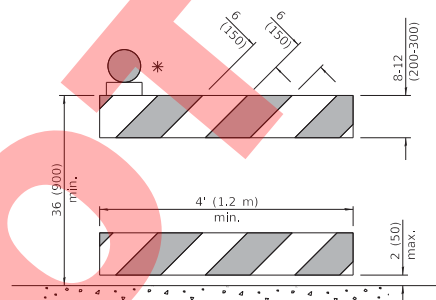

DETECTABLE PEDESTRIAN CHANNELIZING BARRICADE

* Warning lights (if required)

GENERAL NOTES

All heights shown shall be measured above the pavement surface.

All dimensions are in inches (millimeters) unless otherwise shown.

DATE	REVISIONS
1-1-18	Revised END WORK ZONE SPEED LIMIT sign from orange to white background.
1-1-17	Changed FLEXIBLE DELINEATOR to TUBULAR MARKER.

TRAFFIC CONTROL DEVICES

(Sheet 1 of 3)

STANDARD 701901-07

Illinois Department of Transportation

PASSED January 1, 2018
Jan. Allen
 ENGINEER OF OPERATIONS

APPROVED January 1, 2018
Maureen M. Bels
 ENGINEER OF DESIGN AND ENVIRONMENT

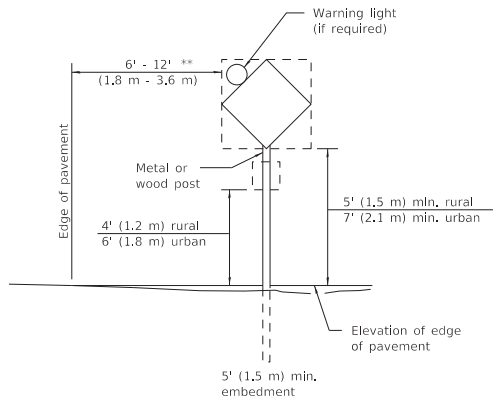

POST MOUNTED SIGNS

** When curb or paved shoulder are present this dimension shall be 24 (600) to the face of curb or 6' (1.8 m) to the outside edge of the paved shoulder.

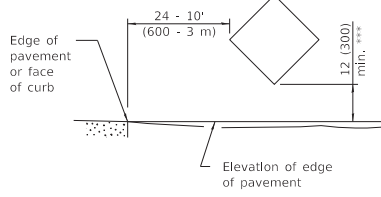

SIGNS ON TEMPORARY SUPPORTS

*** When work operations exceed four days, this dimension shall be 5' (1.5 m) min. If located behind other devices, the height shall be sufficient to be seen completely above the devices.

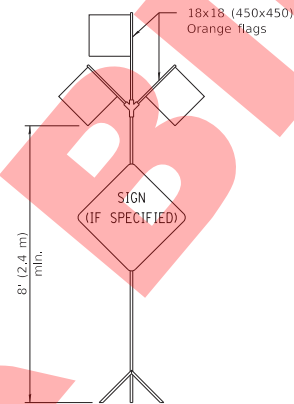

HIGH LEVEL WARNING DEVICE

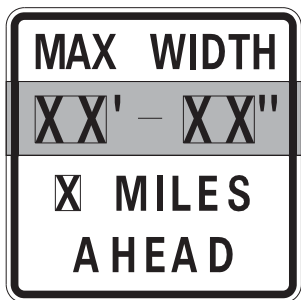

W12-1103-4848

WIDTH RESTRICTION SIGN

XX'-XX" width and X miles are variable.

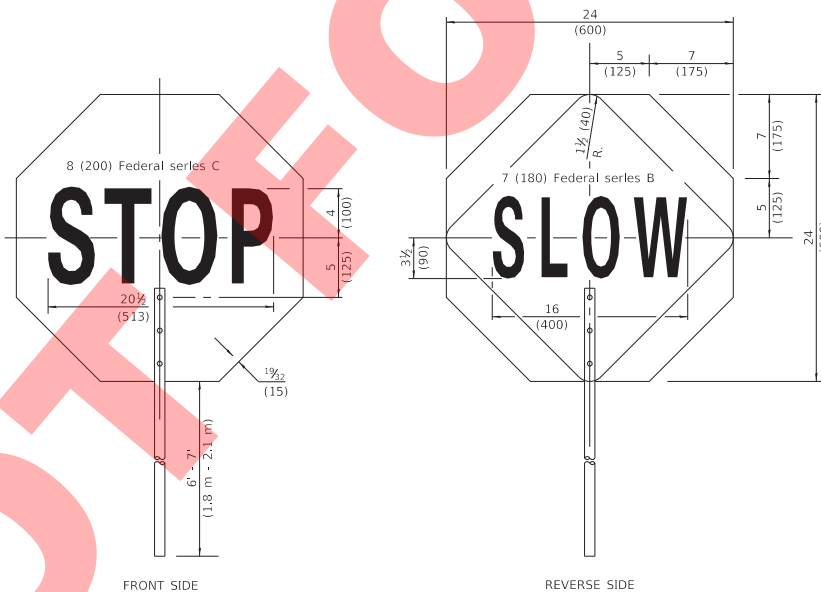

FRONT SIDE

REVERSE SIDE

FLAGGER TRAFFIC CONTROL SIGN



G20-1104(0)-6036



G20-1105(0)-6024

This signing is required for all projects 2 miles (3200 m) or more in length.

ROAD CONSTRUCTION NEXT X MILES sign shall be placed 500' (150 m) in advance of project limits.

END CONSTRUCTION sign shall be erected at the end of the job unless another job is within 2 miles (3200 m).

Dual sign displays shall be utilized on multi-lane highways.

WORK LIMIT SIGNING



W21-1115(0)-3618

R2-1-3648

R10-1108p-3618 ****

R2-1106p-3618

Sign assembly as shown on Standards or as allowed by District Operations.

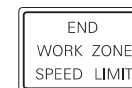

G20-1103-6036

This sign shall be used when the above sign assembly is used.

HIGHWAY CONSTRUCTION

SPEED ZONE SIGNS

**** R10-1108p shall only be used along roadways under the jurisdiction of the State.

TRAFFIC CONTROL DEVICES

(Sheet 2 of 3)

STANDARD 701901-07

Illinois Department of Transportation

PASSED January 1, 2018
Jim Allen
 ENGINEER OF OPERATIONS

APPROVED January 1, 2018
Thomas M. Bello
 ENGINEER OF DESIGN AND ENVIRONMENT

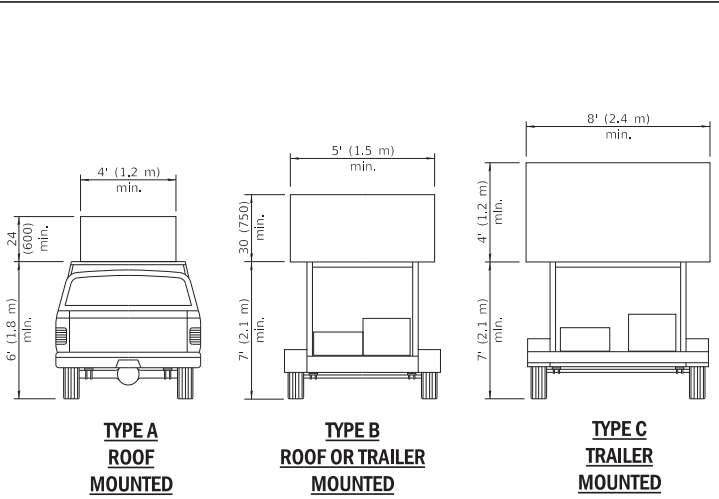

ARROW BOARDS

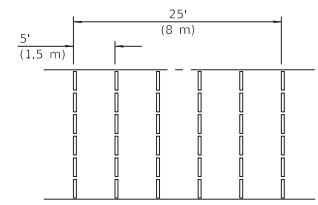
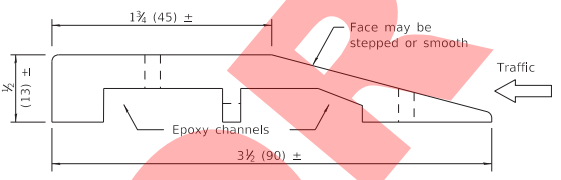
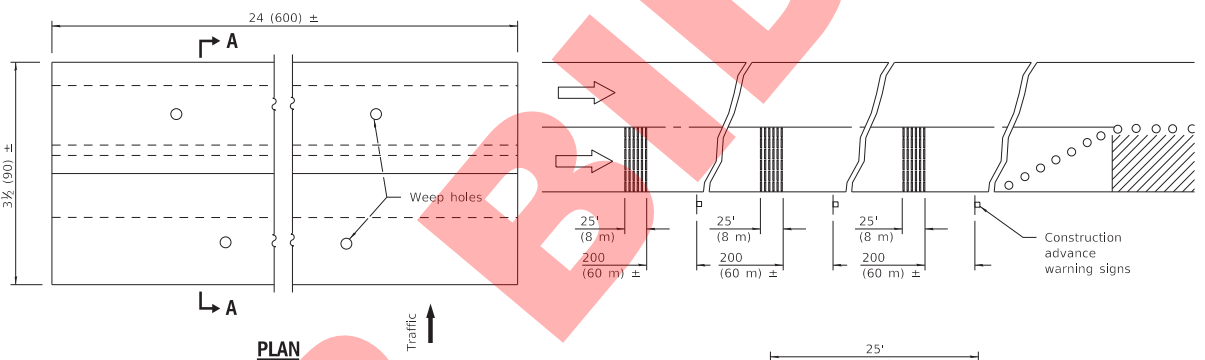

TEMPORARY RUMBLE STRIPS

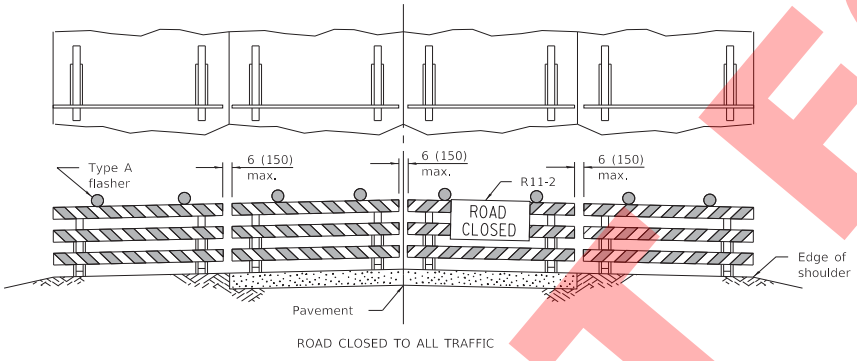

ReflectORIZED striping may be omitted on the back side of the barricades. If a Type III barricade with an attached sign panel which meets NCHRP 350 is not available, the sign may be mounted on an NCHRP 350 temporary sign support directly in front of the barricade.

**TYPICAL APPLICATIONS OF
TYPE III BARRICADES CLOSING A ROAD**

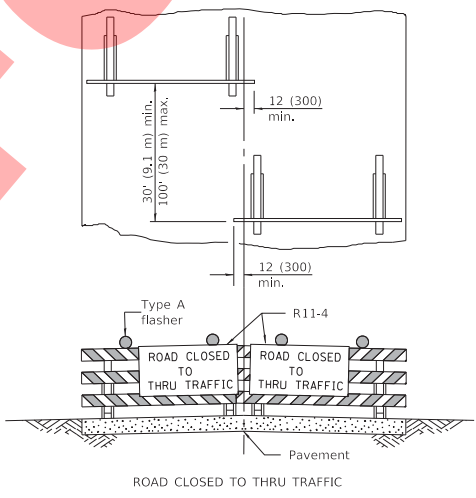

ReflectORIZED striping shall appear on both sides of the barricades. If a Type III barricade with an attached sign panel which meets NCHRP 350 is not available, the signs may be mounted on NCHRP 350 temporary sign supports directly in front of the barricade.

Illinois Department of Transportation	
PASSED	January 1, 2018
<i>Jim Allen</i>	
ENGINEER OF OPERATIONS	
APPROVED	January 1, 2018
<i>Thomas M. Bels</i>	
ENGINEER OF DESIGN AND ENVIRONMENT	

**TRAFFIC CONTROL
DEVICES**

(Sheet 3 of 3)

STANDARD 701901-07

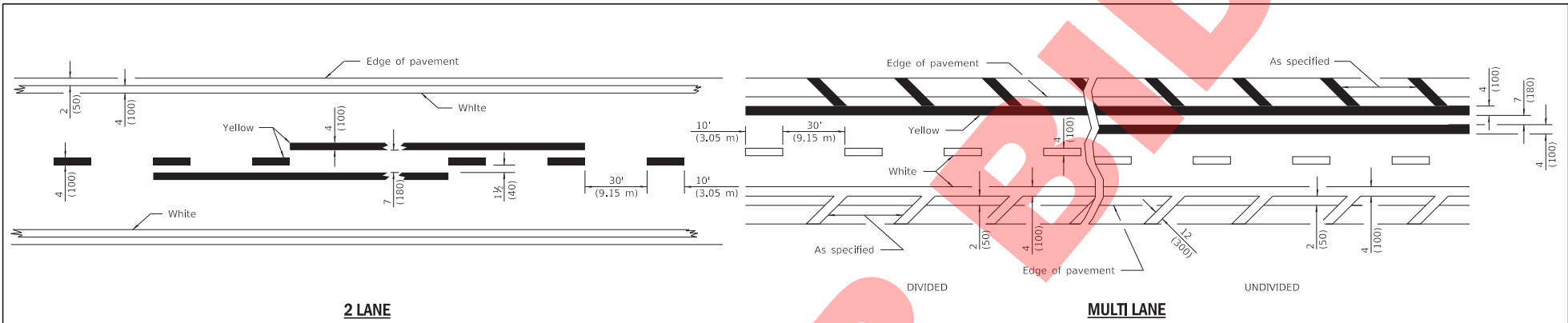

2 LANE

MULTI LANE

LANE AND EDGE LINES

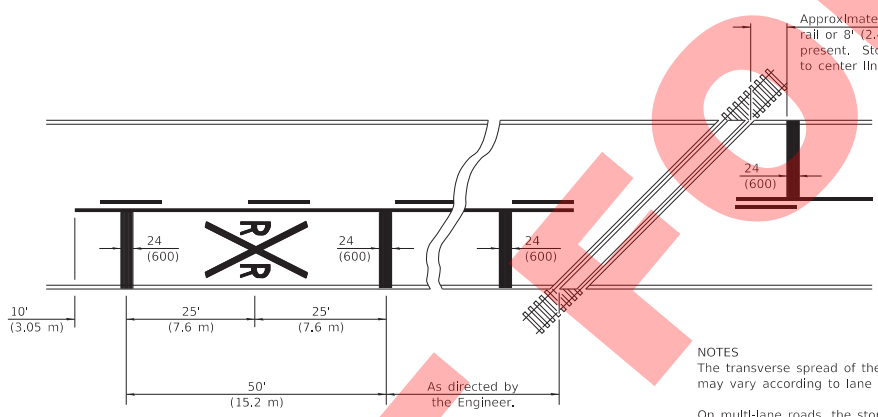

Approximately 15' (4.5 m) from nearest rail or 8' (2.4 m) back from gate, if present. Stop line placed perpendicular to center line.

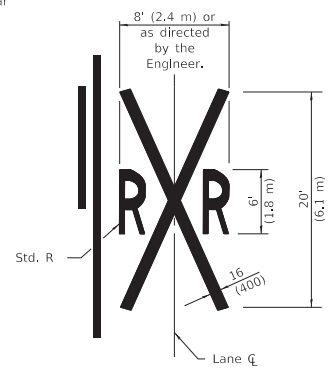

NOTES

The transverse spread of the "X" may vary according to lane width.
 On multi-lane roads, the stop lines shall extend across all approach lanes and separate R XR symbols shall be placed adjacent to each other in each lane.
 When the pavement marking symbol is used, a portion of the symbol should be located directly adjacent to the Advance Warning Sign (W10-1) as placed by Table 2C-4, Condition B of the MUTCD.

PAVEMENT MARKINGS AT RAILROAD-HIGHWAY GRADE CROSSING

All dimensions are in inches (millimeters) unless otherwise shown.

Illinois Department of Transportation

PASSED January 1, 2015
 ENGINEER OF OPERATIONS

APPROVED January 1, 2015
 ENGINEER OF DESIGN AND ENVIRONMENT

DATE	REVISIONS
1-1-15	Added symbols. Revised bike symbol. Revised note for stop line at RR crossing.
1-1-14	Added bike symbol. Renamed 'LANE DROP ARROW' detail to 'LANE-REDUCTION ARROW'.

TYPICAL PAVEMENT MARKINGS

STANDARD 780001-05

(Sheet 1 of 3)

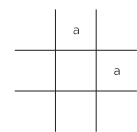
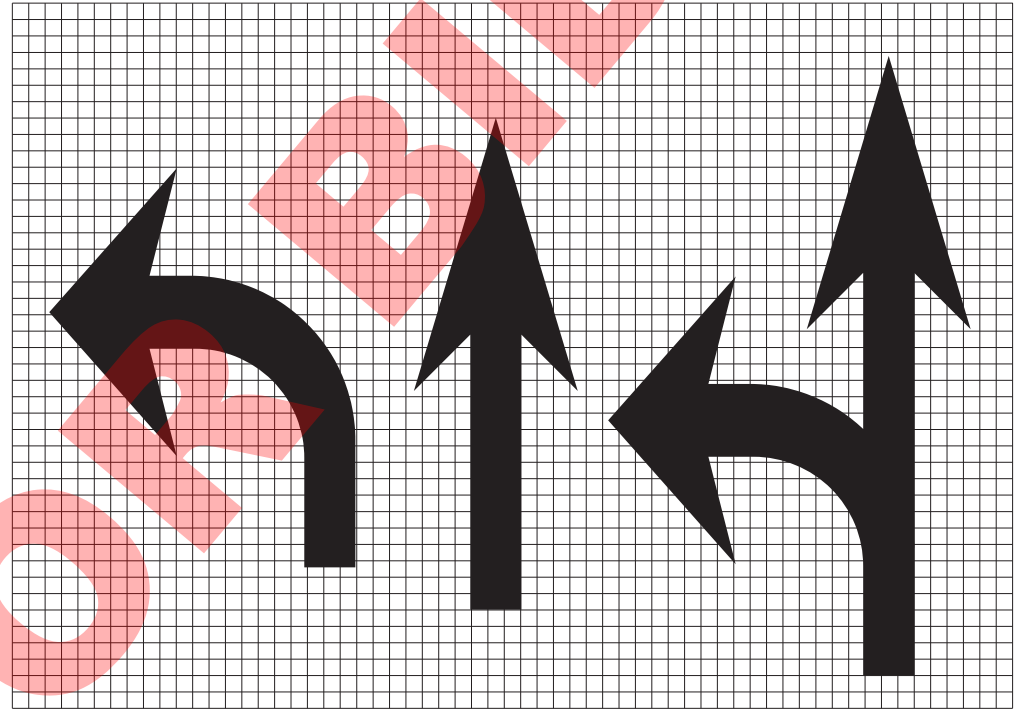

Legend Height	Arrow Size	a
6' (1.8 m)	Small	2.9 (74)
8' (2.4 m)	Large	3.8 (96)

The space between adjacent letters or numerals should be approximately 3 (75) for 6' (1.8 m) legend and 4 (100) for 8' (2.4 m) legend.

LETTER AND ARROW GRID SCALE

Illinois Department of Transportation

PASSED January 1, 2015

ENGINEER OF OPERATIONS

APPROVED January 1, 2015

ENGINEER OF DESIGN AND ENVIRONMENT

ISSUED 11-14-10

TYPICAL PAVEMENT MARKINGS

(Sheet 2 of 3)

STANDARD 780001-05

APPENDIX A
PREVAILING WAGE RATES

NOT FOR BID

Prevailing Wage rates for DuPage County effective Sept. 1, 2017												
Trade Title	Region	Type	Class	Base Wage	Fore-man Wage	M-F OT	OSA	OSH	H/W	Pension	Vacation	Training
ASBESTOS ABT-GEN	ALL	ALL		41.20	42.20	1.5	1.5	2	14.65	12.32	0.00	0.50
ASBESTOS ABT-MEC	ALL	BLD		37.46	39.96	1.5	1.5	2	11.62	11.06	0.00	0.72
BOILERMAKER	ALL	BLD		48.49	52.86	2	2	2	6.97	19.61	0.00	0.90
BRICK MASON	ALL	BLD		45.38	49.92	1.5	1.5	2	10.45	16.68	0.00	0.90
CARPENTER	ALL	ALL		46.35	48.35	1.5	1.5	2	11.79	18.87	0.00	0.63
CEMENT MASON	ALL	ALL		44.25	46.25	2	1.5	2	14.00	17.16	0.00	0.92
CERAMIC TILE FNSHER	ALL	BLD		38.56	38.56	1.5	1.5	2	10.65	11.18	0.00	0.68
COMMUNICATION TECH	ALL	BLD		33.38	36.18	1.5	1.5	2	12.35	19.21	1.45	0.61
ELECTRIC PWR EQMT OP	ALL	ALL		37.89	51.48	1.5	1.5	2	5.00	11.75	0.00	0.38
ELECTRIC PWR EQMT OP	ALL	HWY		41.45	56.38	1.5	1.5	2	5.50	12.87	0.00	0.73
ELECTRIC PWR GRNDMAN	ALL	ALL		29.30	51.48	1.5	1.5	2	5.00	9.09	0.00	0.29
ELECTRIC PWR GRNDMAN	ALL	HWY		32.00	56.38	1.5	1.5	2	5.50	9.92	0.00	0.66
ELECTRIC PWR LINEMAN	ALL	ALL		45.36	51.48	1.5	1.5	2	5.00	14.06	0.00	0.45
ELECTRIC PWR LINEMAN	ALL	HWY		49.67	56.38	1.5	1.5	2	5.50	15.40	0.00	0.88
ELECTRIC PWR TRK DRV	ALL	ALL		30.34	51.48	1.5	1.5	2	5.00	9.40	0.00	0.30
ELECTRIC PWR TRK DRV	ALL	HWY		33.14	56.38	1.5	1.5	2	5.50	10.29	0.00	0.59
ELECTRICIAN	ALL	BLD		39.26	43.26	1.5	1.5	2	12.35	22.08	4.93	0.68
ELEVATOR CONSTRUCTOR	ALL	BLD		51.94	58.43	2	2	2	14.43	14.96	4.16	0.90
FENCE ERECTOR	NE	ALL		39.58	41.58	1.5	1.5	2	13.40	13.90	0.00	0.40
FENCE ERECTOR	W	ALL		45.06	48.66	2	2	2	10.52	20.76	0.00	0.70
GLAZIER	ALL	BLD		42.45	43.95	1.5	1.5	2	14.04	20.14	0.00	0.94
HT/FROST INSULATOR	ALL	BLD		50.50	53.00	1.5	1.5	2	12.12	12.96	0.00	0.72
IRON WORKER	E	ALL		47.33	49.33	2	2	2	14.15	22.39	0.00	0.35
IRON WORKER	W	ALL		45.61	49.25	2	2	2	11.52	22.65	0.00	0.81
LABORER	ALL	ALL		41.20	41.95	1.5	1.5	2	14.65	12.32	0.00	0.50

LATHER	ALL	ALL		46.35	48.35	1.5	1.5	2	11.79	18.87	0.00	0.63
MACHINIST	ALL	BLD		45.35	47.85	1.5	1.5	2	7.26	8.95	1.85	0.00
MARBLE FINISHERS	ALL	ALL		33.95	33.95	1.5	1.5	2	10.45	15.52	0.00	0.47
MARBLE MASON	ALL	BLD		44.63	49.09	1.5	1.5	2	10.45	16.28	0.00	0.59
MATERIAL TESTER I	ALL	ALL		31.20	31.20	1.5	1.5	2	14.65	12.32	0.00	0.50
MATERIALS TESTER II	ALL	ALL		36.20	36.20	1.5	1.5	2	14.65	12.32	0.00	0.50
MILLWRIGHT	ALL	ALL		46.35	48.35	1.5	1.5	2	11.79	18.87	0.00	0.63
OPERATING ENGINEER	ALL	BLD	1	50.10	54.10	2	2	2	18.80	14.35	2.00	1.30
OPERATING ENGINEER	ALL	BLD	2	48.80	54.10	2	2	2	18.80	14.35	2.00	1.30
OPERATING ENGINEER	ALL	BLD	3	46.25	54.10	2	2	2	18.80	14.35	2.00	1.30
OPERATING ENGINEER	ALL	BLD	4	44.50	54.10	2	2	2	18.80	14.35	2.00	1.30
OPERATING ENGINEER	ALL	BLD	5	53.85	54.10	2	2	2	18.80	14.35	2.00	1.30
OPERATING ENGINEER	ALL	BLD	6	51.10	54.10	2	2	2	18.80	14.35	2.00	1.30
OPERATING ENGINEER	ALL	BLD	7	53.10	54.10	2	2	2	18.80	14.35	2.00	1.30
OPERATING ENGINEER	ALL	FLT		38.00	38.00	1.5	1.5	2	18.05	13.60	1.90	1.30
OPERATING ENGINEER	ALL	HWY	1	48.30	52.30	1.5	1.5	2	18.80	14.35	2.00	1.30
OPERATING ENGINEER	ALL	HWY	2	47.75	52.30	1.5	1.5	2	18.80	14.35	2.00	1.30
OPERATING ENGINEER	ALL	HWY	3	45.70	52.30	1.5	1.5	2	18.80	14.35	2.00	1.30
OPERATING ENGINEER	ALL	HWY	4	44.30	52.30	1.5	1.5	2	18.80	14.35	2.00	1.30
OPERATING ENGINEER	ALL	HWY	5	43.10	52.30	1.5	1.5	2	18.80	14.35	2.00	1.30
OPERATING ENGINEER	ALL	HWY	6	51.30	52.30	1.5	1.5	2	18.80	14.35	2.00	1.30
OPERATING ENGINEER	ALL	HWY	7	49.30	52.30	1.5	1.5	2	18.80	14.35	2.00	1.30
ORNAMNTL IRON WORKER	E	ALL		46.75	49.25	2	2	2	13.90	19.79	0.00	0.75
ORNAMNTL IRON WORKER	W	ALL		45.06	48.66	2	2	2	10.52	20.76	0.00	0.70
PAINTER	ALL	ALL		44.18	46.18	1.5	1.5	1.5	10.30	8.20	0.00	1.35
PAINTER SIGNS	ALL	BLD		37.45	42.05	1.5	1.5	2	2.60	3.18	0.00	0.00
PILEDRIVER	ALL	ALL		46.35	48.35	1.5	1.5	2	11.79	18.87	0.00	0.63
PIPEFITTER	ALL	BLD		47.50	50.50	1.5	1.5	2	10.05	17.85	0.00	2.12
PLASTERER	ALL	BLD		42.75	45.31	1.5	1.5	2	14.00	15.71	0.00	0.89
PLUMBER	ALL	BLD		49.25	52.20	1.5	1.5	2	14.34	13.35	0.00	1.28

ROOFER	ALL	BLD		42.30	45.30	1.5	1.5	2	9.08	12.14	0.00	0.58
SHEETMETAL WORKER	ALL	BLD		45.77	47.77	1.5	1.5	2	10.65	14.10	0.00	0.82
SPRINKLER FITTER	ALL	BLD		47.20	49.20	1.5	1.5	2	12.25	11.55	0.00	0.55
STEEL ERECTOR	E	ALL		42.07	44.07	2	2	2	13.45	19.59	0.00	0.35
STEEL ERECTOR	W	ALL		45.06	48.66	2	2	2	10.52	20.76	0.00	0.70
STONE MASON	ALL	BLD		45.38	49.92	1.5	1.5	2	10.45	16.68	0.00	0.90
TERRAZZO FINISHER	ALL	BLD		40.54	40.54	1.5	1.5	2	10.65	12.76	0.00	0.73
TERRAZZO MASON	ALL	BLD		44.38	47.88	1.5	1.5	2	10.65	14.15	0.00	0.82
TILE MASON	ALL	BLD		45.49	49.49	1.5	1.5	2	10.65	13.88	0.00	0.86
TRAFFIC SAFETY WRKR	ALL	HWY		33.50	35.10	1.5	1.5	2	8.10	7.62	0.00	0.25
TRUCK DRIVER	ALL	ALL	1	36.30	36.85	1.5	1.5	2	8.10	9.76	0.00	0.15
TRUCK DRIVER	ALL	ALL	2	36.45	36.85	1.5	1.5	2	8.10	9.76	0.00	0.15
TRUCK DRIVER	ALL	ALL	3	36.65	36.85	1.5	1.5	2	8.10	9.76	0.00	0.15
TRUCK DRIVER	ALL	ALL	4	36.85	36.85	1.5	1.5	2	8.10	9.76	0.00	0.15
TUCKPOINTER	ALL	BLD		44.17	45.17	1.5	1.5	2	10.45	15.04	0.00	0.88

Legend

M-F OT Unless otherwise noted, OT pay is required for any hour greater than 8 worked each day, Mon through Fri. The number listed is the multiple of the base wage.

OSA Overtime pay required for every hour worked on Saturdays

OSH Overtime pay required for every hour worked on Sundays and Holidays

H/W Health/Welfare benefit

Explanations DUPAGE COUNTY

IRON WORKERS AND FENCE ERECTOR (WEST) - West of Route 53.

The following list is considered as those days for which holiday rates of wages for work performed apply: New Years Day, Memorial Day, Fourth of July, Labor Day, Thanksgiving Day, Christmas Day and Veterans Day in some classifications/counties. Generally, any of these holidays which fall on a Sunday is celebrated on the following Monday. This then makes work performed on that Monday payable at the appropriate overtime rate for holiday pay. Common practice in a given local may alter certain days of celebration. If in doubt, please check with IDOL.

EXPLANATION OF CLASSES

ASBESTOS - GENERAL - removal of asbestos material/mold and hazardous materials from any place in a building, including mechanical systems where those mechanical systems are to be removed. This includes the removal of asbestos materials/mold and hazardous materials from ductwork or pipes in a building when the building is to be demolished at the time or at some close future date.

ASBESTOS - MECHANICAL - removal of asbestos material from mechanical systems, such as pipes, ducts, and boilers, where the mechanical systems are to remain.

TRAFFIC SAFETY - work associated with barricades, horses and drums used to reduce lane usage on highway work, the installation and removal of temporary lane markings, and the installation and removal of temporary road signs.

CERAMIC TILE FINISHER

The grouting, cleaning, and polishing of all classes of tile, whether for interior or exterior purposes, all burned, glazed or unglazed products; all composition materials, granite tiles, warning detectable tiles, cement tiles, epoxy composite materials, pavers, glass, mosaics, fiberglass, and all substitute materials, for tile made in tile-like units; all mixtures in tile like form of cement, metals, and other materials that are for and intended for use as a finished floor surface, stair treads, promenade roofs, walks, walls, ceilings, swimming pools, and all other places where tile is to form a finished interior or exterior. The mixing of all setting mortars including but not limited to thin-set mortars, epoxies, wall mud, and any other sand and cement mixtures or adhesives when used in the preparation, installation, repair, or maintenance of tile and/or similar materials. The handling and unloading of all sand, cement, lime, tile, fixtures, equipment, adhesives, or any other materials to be used in the preparation, installation, repair, or maintenance of tile and/or similar materials. Ceramic Tile Finishers shall fill all joints and voids regardless of method on all tile work, particularly and especially after installation of said tile work. Application of any and all protective coverings to all types of tile installations including, but not be limited to, all soap compounds, paper products, tapes, and all polyethylene coverings, plywood, masonite, cardboard, and any new type of products that may be used to protect tile installations, Blastrac equipment, and all floor scarifying equipment used in preparing floors to receive tile. The clean up and removal of all waste and materials. All demolition of existing tile floors and walls to be re-tiled.

COMMUNICATIONS TECHNICIAN

Low voltage installation, maintenance and removal of telecommunication facilities (voice, sound, data and video) including telephone and data inside wire, interconnect, terminal equipment, central offices, PABX, fiber optic cable and equipment, micro waves, V-SAT, bypass, CATV, WAN (wide area networks), LAN (local area networks), and ISDN (integrated system digital network), pulling of wire in raceways, but not the installation of raceways.

MARBLE FINISHER

Loading and unloading trucks, distribution of all materials (all stone, sand, etc.), stocking of floors with material, performing all rigging for heavy work, the handling of all material that may be needed for the installation of such materials, building of scaffolding, polishing if needed, patching, waxing of material if damaged, pointing up, caulking, grouting and cleaning of marble, holding water on diamond or Carborundum blade or saw for setters cutting, use of tub saw or any other saw needed for preparation of material, drilling of holes for wires that anchor material set by setters, mixing up of molding plaster for installation of material, mixing up thin set for the installation of material, mixing up of sand to cement for the installation of material and such other work as may be required in helping a Marble Setter in the handling of all material in the erection or installation of interior marble, slate, travertine, art marble, serpentine, alberene stone, blue stone, granite and other stones (meaning as to stone any foreign or domestic materials as are specified and used in building interiors and exteriors and customarily known as stone in the trade), carrara, sanionyx, vitrolite and similar opaque glass and the laying of all marble tile, terrazzo tile, slate tile and precast tile, steps, risers treads, base, or any other materials that may be used as substitutes for any of the aforementioned materials and which are used on interior and exterior which are installed in a similar manner.

MATERIAL TESTER I: Hand coring and drilling for testing of materials; field inspection of uncured concrete and asphalt.

MATERIAL TESTER II: Field inspection of welds, structural steel, fireproofing, masonry, soil, facade, reinforcing steel, formwork, cured concrete, and concrete and asphalt batch plants; adjusting proportions of bituminous mixtures.

OPERATING ENGINEER - BUILDING

Class 1. Asphalt Plant; Asphalt Spreader; Autograde; Backhoes with Caisson Attachment; Batch Plant; Benoto (requires Two Engineers); Boiler and Throttle Valve; Caisson Rigs; Central Redi-Mix Plant; Combination Back Hoe Front End-loader Machine; Compressor and Throttle Valve; Concrete Breaker (Truck Mounted); Concrete Conveyor; Concrete Conveyor (Truck Mounted); Concrete Paver Over 27E cu. ft; Concrete Paver 27E cu. ft. and Under; Concrete Placer; Concrete Placing Boom; Concrete Pump (Truck Mounted); Concrete Tower; Cranes, All; Cranes, Hammerhead; Cranes, (GCI and similar Type); Creter Crane; Spider Crane; Crusher, Stone, etc.; Derricks, All; Derricks, Traveling; Formless Curb and Gutter Machine; Grader, Elevating; Grouting Machines; Heavy Duty Self-Propelled Transporter or Prime Mover; Highlift Shovels or Front Endloader 2-1/4 yd. and over; Hoists, Elevators, outside type rack and pinion and similar machines; Hoists, One, Two and Three Drum; Hoists, Two Tugger One Floor; Hydraulic Backhoes; Hydraulic Boom Trucks; Hydro Vac (and similar equipment); Locomotives, All; Motor Patrol; Lubrication Technician; Manipulators; Pile Drivers and Skid Rig; Post Hole Digger; Pre-Stress Machine; Pump Cretes Dual Ram; Pump Cretes: Squeeze Cretes-Screw Type Pumps; Gypsum Bulker and Pump; Raised and Blind Hole Drill; Roto Mill Grinder; Scoops - Tractor Drawn; Slip-Form Paver; Straddle Buggies; Operation of Tie Back Machine; Tournapull; Tractor with Boom and Side Boom; Trenching Machines.

Class 2. Boilers; Broom, All Power Propelled; Bulldozers; Concrete Mixer (Two Bag and Over); Conveyor, Portable; Forklift Trucks; Highlift Shovels or Front Endloaders under 2-1/4 yd.; Hoists, Automatic; Hoists, Inside Elevators; Hoists, Sewer Dragging Machine; Hoists, Tugger Single Drum;

Laser Screed; Rock Drill (Self-Propelled); Rock Drill (Truck Mounted); Rollers, All; Steam Generators; Tractors, All; Tractor Drawn Vibratory Roller; Winch Trucks with "A" Frame.

Class 3. Air Compressor; Combination Small Equipment Operator; Generators; Heaters, Mechanical; Hoists, Inside Elevators (remodeling or renovation work); Hydraulic Power Units (Pile Driving, Extracting, and Drilling); Pumps, over 3" (1 to 3 not to exceed a total of 300 ft.); Low Boys; Pumps, Well Points; Welding Machines (2 through 5); Winches, 4 Small Electric Drill Winches.

Class 4. Bobcats and/or other Skid Steer Loaders; Oilers; and Brick Forklift.

Class 5. Assistant Craft Foreman.

Class 6. Gradall.

Class 7. Mechanics; Welders.

OPERATING ENGINEERS - HIGHWAY CONSTRUCTION

Class 1. Asphalt Plant; Asphalt Heater and Planer Combination; Asphalt Heater Scarfire; Asphalt Spreader; Autograder/GOMACO or other similar type machines; ABG Paver; Backhoes with Caisson Attachment; Ballast Regulator; Belt Loader; Caisson Rigs; Car Dumper; Central Redi-Mix Plant; Combination Backhoe Front Endloader Machine, (1 cu. yd. Backhoe Bucket or over or with attachments); Concrete Breaker (Truck Mounted); Concrete Conveyor; Concrete Paver over 27E cu. ft.; Concrete Placer; Concrete Tube Float; Cranes, all attachments; Cranes, Tower Cranes of all types: Creter Crane; Spider Crane; Crusher, Stone, etc.; Derricks, All; Derrick Boats; Derricks, Traveling; Dredges; Elevators, Outside type Rack & Pinion and Similar Machines; Formless Curb and Gutter Machine; Grader, Elevating; Grader, Motor Grader, Motor Patrol, Auto Patrol, Form Grader, Pull Grader, Subgrader; Guard Rail Post Driver Truck Mounted; Hoists, One, Two and Three Drum; Heavy Duty Self-Propelled Transporter or Prime Mover; Hydraulic Backhoes; Backhoes with shear attachments up to 40' of boom reach; Lubrication Technician; Manipulators; Mucking Machine; Pile Drivers and Skid Rig; Pre-Stress Machine; Pump Cretes Dual Ram; Rock Drill - Crawler or Skid Rig; Rock Drill - Truck Mounted; Rock/Track Tamper; Roto Mill Grinder; Slip-Form Paver; Snow Melters; Soil Test Drill Rig (Truck Mounted); Straddle Buggies; Hydraulic Telescoping Form (Tunnel); Operation of Tieback Machine; Tractor Drawn Belt Loader; Tractor Drawn Belt Loader (with attached pusher - two engineers); Tractor with Boom; Tractaire with Attachments; Traffic Barrier Transfer Machine; Trenching; Truck Mounted Concrete Pump with Boom; Raised or Blind Hole Drills (Tunnel Shaft); Underground Boring and/or Mining Machines 5 ft. in diameter and over tunnel, etc; Underground Boring and/or Mining Machines under 5 ft. in diameter; Wheel Excavator; Widener (APSCO).

Class 2. Batch Plant; Bituminous Mixer; Boiler and Throttle Valve; Bulldozers; Car Loader Trailing Conveyors; Combination Backhoe Front Endloader Machine (Less than 1 cu. yd. Backhoe Bucket or over or with attachments); Compressor and Throttle Valve; Compressor, Common Receiver (3); Concrete Breaker or Hydro Hammer; Concrete Grinding Machine; Concrete Mixer or Paver 7S Series to and including 27 cu. ft.;

Concrete Spreader; Concrete Curing Machine, Burlap Machine, Belting Machine and Sealing Machine; Concrete Wheel Saw; Conveyor Muck Cars (Haglund or Similar Type); Drills, All; Finishing Machine - Concrete; Highlift Shovels or Front Endloader; Hoist - Sewer Dragging Machine; Hydraulic Boom Trucks (All Attachments); Hydro-Blaster; Hydro Excavating (excluding hose work); Laser Screed; All Locomotives, Dinky; Off-Road Hauling Units (including articulating) Non Self-Loading Ejection Dump; Pump Cretes: Squeeze Cretes - Screw Type Pumps, Gypsum Bulker and Pump; Roller, Asphalt; Rotary Snow Plows; Rototiller, Seaman, etc., self-propelled; Self-Propelled Compactor; Spreader - Chip - Stone, etc.; Scraper - Single/Twin Engine/Push and Pull; Scraper - Prime Mover in Tandem (Regardless of Size); Tractors pulling attachments, Sheeps Foot, Disc, Compactor, etc.; Tug Boats.

Class 3. Boilers; Brooms, All Power Propelled; Cement Supply Tender; Compressor, Common Receiver (2); Concrete Mixer (Two Bag and Over); Conveyor, Portable; Farm-Type Tractors Used for Mowing, Seeding, etc.; Forklift Trucks; Grouting Machine; Hoists, Automatic; Hoists, All Elevators; Hoists, Tugger Single Drum; Jeep Diggers; Low Boys; Pipe Jacking Machines; Post-Hole Digger; Power Saw, Concrete Power Driven; Pug Mills; Rollers, other than Asphalt; Seed and Straw Blower; Steam Generators; Stump Machine; Winch Trucks with "A" Frame; Work Boats; Tamper-Form-Motor Driven.

Class 4. Air Compressor; Combination - Small Equipment Operator; Directional Boring Machine; Generators; Heaters, Mechanical; Hydraulic Power Unit (Pile Driving, Extracting, or Drilling); Light Plants, All (1 through 5); Pumps, over 3" (1 to 3 not to exceed a total of 300 ft.); Pumps, Well Points; Vacuum Trucks (excluding hose work); Welding Machines (2 through 5); Winches, 4 Small Electric Drill Winches.

Class 5. SkidSteer Loader (all); Brick Forklifts; Oilers.

Class 6. Field Mechanics and Field Welders

Class 7. Dowell Machine with Air Compressor; Gradall and machines of like nature.

OPERATING ENGINEER - FLOATING

Diver. Diver Wet Tender, Diver Tender, ROV Pilot, ROV Tender

TRUCK DRIVER - BUILDING, HEAVY AND HIGHWAY CONSTRUCTION

Class 1. Two or three Axle Trucks. A-frame Truck when used for transportation purposes; Air Compressors and Welding Machines, including those pulled by cars, pick-up trucks and tractors; Ambulances; Batch Gate Lockers; Batch Hopperman; Car and Truck Washers; Carry-alls; Fork Lifts and Hoisters; Helpers; Mechanics Helpers and Greasers; Oil Distributors 2-man operation; Pavement Breakers; Pole Trailer, up to 40 feet; Power Mower Tractors; Self-propelled Chip Spreader; Skipman; Slurry Trucks, 2-man operation; Slurry Truck Conveyor Operation, 2 or 3 man; Teamsters; Unskilled Dumpman; and Truck Drivers hauling warning lights, barricades, and portable toilets on the job site.

Class 2. Four axle trucks; Dump Crets and Adgetors under 7 yards; Dumpsters, Track Trucks, Euclids, Hug Bottom Dump Turnapulls or Turnatrailers when pulling other than self-loading equipment or similar equipment under 16 cubic yards; Mixer Trucks under 7 yards; Ready-mix Plant Hopper Operator, and Winch Trucks, 2 Axles.

Class 3. Five axle trucks; Dump Crets and Adgetors 7 yards and over; Dumpsters, Track Trucks, Euclids, Hug Bottom Dump Turnatrailers or turnapulls when pulling other than self-loading equipment or similar equipment over 16 cubic yards; Explosives and/or Fission Material Trucks; Mixer Trucks 7 yards or over; Mobile Cranes while in transit; Oil Distributors, 1-man operation; Pole Trailer, over 40 feet; Pole and Expandable Trailers hauling material over 50 feet long; Slurry trucks, 1-man operation; Winch trucks, 3 axles or more; Mechanic--Truck Welder and Truck Painter.

Class 4. Six axle trucks; Dual-purpose vehicles, such as mounted crane trucks with hoist and accessories; Foreman; Master Mechanic; Self-loading equipment like P.B. and trucks with scoops on the front.

TERRAZZO FINISHER

The handling of sand, cement, marble chips, and all other materials that may be used by the Mosaic Terrazzo Mechanic, and the mixing, grinding, grouting, cleaning and sealing of all Marble, Mosaic, and Terrazzo work, floors, base, stairs, and wainscoting by hand or machine, and in addition, assisting and aiding Marble, Masonic, and Terrazzo Mechanics.

Other Classifications of Work:

For definitions of classifications not otherwise set out, the Department generally has on file such definitions which are available. If a task to be performed is not subject to one of the classifications of pay set out, the Department will upon being contacted state which neighboring county has such a classification and provide such rate, such rate being deemed to exist by reference in this document. If no neighboring county rate applies to the task, the Department shall undertake a special determination, such special determination being then deemed to have existed under this determination. If a project requires these, or any classification not listed, please contact IDOL at 217-782-1710 for wage rates or clarifications.

LANDSCAPING

Landscaping work falls under the existing classifications for laborer, operating engineer and truck driver. The work performed by landscape plantsman and landscape laborer is covered by the existing classification of laborer. The work performed by landscape operators (regardless of equipment used or its size) is covered by the classifications of operating engineer. The work performed by landscape truck drivers (regardless of size of truck driven) is covered by the classifications of truck driver.

MATERIAL TESTER & MATERIAL TESTER/INSPECTOR I AND II

Notwithstanding the difference in the classification title, the classification entitled "Material Tester I" involves the same job duties as the classification entitled "Material Tester/Inspector I". Likewise, the classification entitled "Material Tester II" involves the same job duties as the classification entitled "Material Tester/Inspector II".

NOT FOR BID

APPENDIX B

IRMA CONTRACTUAL INSURANCE GUIDELINES

NOT FOR BID

IRMA

CONTRACTUAL INSURANCE GUIDELINES

I. INSURANCE REQUIREMENTS

Contractor shall procure and maintain, for the duration of the contract, insurance against claims for injuries to persons or damages to property, which may arise from or in connection with the performance of the work hereunder by the Contractor, his agents, representatives, employees or subcontractors.

MINIMUM SCOPE OF INSURANCE

Coverage shall be at least as broad as:

- A. Insurance Services Office Commercial General Liability occurrence form CG 0001 with the member named as additional insured, on a form at least as broad as the attached sample endorsement including ISO Additional Insured Endorsement CG 2010 (Exhibit A), CG 2026 (Exhibit B).

CG2037 - Completed Operations – (Exhibit C)
Required if box is checked ; and

- B. Owners and Contractors Protective Liability (OCP) policy with the member as insured

Required if box is checked ; and

- C. Insurance Service Office Business Auto Liability coverage form number CA 0001, Symbol 01 "Any Auto."

- D. Workers' Compensation as required by the Workers' Compensation Act of the State of Illinois and Employers' Liability insurance.

Coverage required for employee exposure to lead, if box is checked

- E. Builder Risk Property Coverage with member as loss payee

Required if box is checked .

- F. Environmental Impairment/Pollution Liability Coverage for pollution incidents as a result of a claim for bodily injury, property damage or remediation costs from an incident at, on or migrating beyond the contracted work site. Coverage shall be extended to Non-Owned Disposal sites resulting from a pollution incident at, on or mitigating beyond the site; and also provide coverage for incidents occurring during transportation of pollutants.

Required if box is checked .

MINIMUM LIMITS OF INSURANCE

Contractor shall maintain limits no less than the following, **if required under above scope**:

- A. Commercial General Liability: \$1,000,000 combined single limit per occurrence for bodily injury, and property damage and \$1,000,000 per occurrence for personal injury. The general aggregate shall be twice the required occurrence limit. Minimum General Aggregate shall be no less than \$2,000,000 or a project/contract specific aggregate of \$1,000,000.

- B. Owners and Contractors Protective Liability (OCP): \$1,000,000 combined single limit per occurrence for bodily injury and property damage.
- C. Business Automobile Liability: \$1,000,000 combined single limit per accident for bodily injury and property damage.
- D. Workers' Compensation and Employers' Liability: Workers' Compensation coverage with statutory limits and Employers' Liability limits of \$500,000 per accident.
- E. Builder's Risk: Shall insure against "All Risk" of physical damage, including water damage (flood and hydrostatic pressure not excluded), on a completed replacement cost basis.
- F. Environmental Impairment/Pollution Liability: \$1,000,000 combined single limit per occurrence for bodily injury, property damage and remediation costs.

DEDUCTIBLES AND SELF-INSURED RETENTIONS

Any deductibles or self-insured retentions must be declared to and approved by the member. At the option of the member, either: the insurer shall reduce or eliminate such deductibles or self-insured retentions as respects the member, its officials, employees, agents and volunteers; or the Contractor shall procure a bond guaranteeing payment of losses and related investigation, claim administration and defense expenses.

OTHER INSURANCE PROVISIONS

The policies are to contain, or be endorsed to contain, the following provisions:

A. General Liability and Automobile Liability Coverages

1. The member, its officials, agents, employees and volunteers are to be covered as additional insureds as respects: liability arising out of the Contractor's work, including activities performed by or on behalf of the Contractor; products and completed operations of the Contractor; premises owned, leased or used by the Contractor; or automobiles owned, leased, hired or borrowed by the Contractor. The coverage shall contain no special limitations on the scope of protection afforded to the member, its officials, agents, employees and volunteers.
2. The Contractor's insurance coverage shall be primary as respects the member, its officials, employees, agents and volunteers. Any insurance or self-insurance maintained by the member, its officials, agents, employees and volunteers shall be excess of Contractor's insurance and shall not contribute with it.
3. Any failure to comply with reporting provisions of the policies shall not affect coverage provided to the member, its officials, employees, agents and volunteers.
4. The Contractor's insurance shall contain a Severability of Interests/Cross Liability clause or language stating that Contractor's insurance shall apply separately to each insured against whom claim is made or suit is brought, except with respect to the limits of the insurer's liability.
5. If any commercial general liability insurance is being provided under an excess

or umbrella liability policy that does not “follow form,” then the Contractor shall be required to name the member, its officials, employees, agents and volunteers as additional insureds.

6. All general liability coverages shall be provided on an occurrence policy form. Claims-made general liability policies will not be accepted.
7. The contractor and all subcontractors hereby agree to waive any limitation as to the amount of contribution recoverable against them by member. This specifically includes any limitation imposed by any state statute, regulation, or case law including any Workers’ Compensation Act provision that applies a limitation to the amount recoverable in contribution such as *Kotecki v. Cyclops Welding*.

B. Workers' Compensation and Employers' Liability Coverage

The insurer shall agree to waive all rights of subrogation against the member, its officials, employees, agents and volunteers for losses arising from work performed by Contractor for the municipality.

1. NCCI Alternate Employer Endorsement (WC 000301) in place to insure that workers’ compensation coverage applies under contractor’s coverage rather than member’s if the member is borrowing, leasing or in day to day control of contractors employee.

Required if box is checked .

C. Professional Liability (Required if box is checked)

1. Professional liability insurance with limits not less than \$1,000,00 each claim with respect to negligent acts, errors and omissions in connection with professional services to be provided under the contract, with a deductible not-to-exceed \$50,000 without prior written approval.
2. If the policy is written on a claims-made form, the retroactive date must be equal to or preceding the effective date of the contract. In the event the policy is cancelled, non-renewed or switched to an occurrence form, the Contractor shall be required to purchase supplemental extending reporting period coverage for a period of not less than three (3) years.
3. Provide a certified copy of actual policy for review.
4. Recommended Required Coverage (architect, engineer, surveyor, consultant): Professional liability insurance that provides indemnification and defense for injury or damage arising out of acts, errors, or omissions in providing the following professional services, but not limited to the following:
 - a. Preparing, approving or failure to prepare or approve maps, drawings, opinions, report, surveys, change orders, designs or specifications;
 - b. Providing direction, instruction, supervision, inspection, engineering services or failing to provide them, if that is the primary cause of injury or damage.

D. All Coverages

Each insurance policy required shall have the member expressly endorsed onto the policy as a Cancellation Notice Recipient. Should any of the policies be cancelled before the expiration date thereof, notice will be delivered in accordance with the policy provisions.

ACCEPTABILITY OF INSURERS

Insurance is to be placed with insurers with a Best's rating of no less than A-, VII and licensed to do business in the State of Illinois.

VERIFICATION OF COVERAGE

Contractor shall furnish the member with certificates of insurance naming the member, its officials, employees, agents and volunteers as additional insureds (Exhibit D), and with original endorsements affecting coverage required by this clause. The certificates and endorsements for each insurance policy are to be signed by a person authorized by that insurer to bind coverage on its behalf. The certificates and endorsements are to be received and approved by the member before any work commences. The following additional insured endorsements may be utilized: ISO Additional Insured Endorsements CG 2010 (Exhibit A) or CG 2026 (Exhibit B), and CG 2037 (Exhibit C) – Completed Operations, where required. The member reserves the right to request full certified copies of the insurance policies and endorsements.

SUBCONTRACTORS

Contractor shall include all subcontractors as insureds under its policies or shall furnish separate certificates and endorsements for each subcontractor. All coverages for subcontractors shall be subject to all of the requirements stated herein.

ASSUMPTION OF LIABILITY

The contractor assumes liability for all injury to or death of any person or persons including employees of the contractor, any sub-contractor, any supplier or any other person and assumes liability for all damage to property sustained by any person or persons occasioned by or in any way arising out of any work performed pursuant to this agreement.

II. INDEMNITY/HOLD HARMLESS PROVISION

To the fullest extent permitted by law, the Contractor hereby agrees to defend, indemnify and hold harmless the member, its officials, employees and agents against all injuries, deaths, loss, damages, claims, patent claims, suits, liabilities, judgments, cost and expenses, which may in anywise accrue against the member, its officials, agents and employees, arising in whole or in part or in consequence of the performance of this work by the Contractor, its employees, or subcontractors, or which may in anywise result therefore, except that arising out of the sole legal cause of the member, its employees or agents, the Contractor shall, at its own expense, appear, defend and pay all charges of attorneys and all costs and other expenses arising therefore or incurred in connections therewith, and, if any judgment shall be rendered against the member, its officials, employees and agents, in any such action, the Contractor shall, at its own expense, satisfy and discharge the same.

Contractor expressly understands and agrees that any performance bond or insurance policies required by this contract, or otherwise provided by the Contractor, shall in no way limit the responsibility to indemnify, keep and save harmless and defend the member, its

officials, employees and agents as herein provided.

The Contractor further agrees that to the extent that money is due the Contractor by virtue of this contract as shall be considered necessary in the judgment of the member, may be retained by the member to protect itself against said loss until such claims, suits, or judgments shall have been settled or discharged and/or evidence to that effect shall have been furnished to the satisfaction of the member.

III. SAFETY/LOSS PREVENTION

Safety/Loss Prevention Program Requirements

- Successful bidder will provide written confirmation that a safety/loss prevention program was in place at least 90 days prior to submitting the bid proposal.
- Evidence of completed employee safety training can be provided.

Regulatory Requirements

- Successful bidder must comply with all applicable laws, regulations, and rules promulgated by any Federal, State, County, Municipal and/or other governmental unit or regulatory body now in effect or which may be in effect during the performance of the work. Included within the scope of the laws, regulations, and rules referred to in this paragraph but in no way to operate as a limitation, are Occupational Safety & Health Act (OSHA), Illinois Department of Labor (IDOL), Department of Transportation, all forms of traffic regulations, public utility, Intrastate and Interstate Commerce Commission regulations, Workers' Compensation Laws, Prevailing Wage Laws, the Social Security Act of the Federal Government and any of its titles, the Illinois Department of Human Rights, Human Rights Commission, or EEOC statutory provisions and rules and regulations.
- Evidence of specific regulatory compliance will be provided by bidder, if required by owner.

EXHIBIT A

POLICY NUMBER:

COMMERCIAL GENERAL LIABILITY
CG 20 10 07 04

THIS ENDORSEMENT CHANGES THE POLICY. PLEASE READ IT CAREFULLY.

**ADDITIONAL INSURED – OWNERS, LESSEES OR
CONTRACTORS – SCHEDULED PERSON OR
ORGANIZATION**

This endorsement modifies insurance provided under the following:

COMMERCIAL GENERAL LIABILITY COVERAGE PART

SCHEDULE

Name Of Additional Insured Person(s) Or Organization(s):	Location(s) Of Covered Operations
Information required to complete this Schedule, if not shown above, will be shown in the Declarations.	

A. Section II – Who Is An Insured is amended to include as an additional insured the person(s) or organization(s) shown in the Schedule, but only with respect to liability for "bodily injury," "property damage" or "personal and advertising injury" caused, in whole or in part, by:

1. Your acts or omissions; or
2. The acts or omissions of those acting on your behalf;

in the performance of your ongoing operations for the additional insured(s) at the location(s) designated above.

B. With respect to the insurance afforded to these additional insureds, the following additional exclusions apply:

This insurance does not apply to "bodily injury" or "property damage" occurring after:

1. All work, including materials, parts or equipment furnished in connection with such work, on the project (other than service, maintenance or repairs) to be performed by or on behalf of the additional insured(s) at the location of the covered operations has been completed; or
2. That portion of "your work" out of which the injury or damage arises has been put to its intended use by any person or organization other than another contractor or subcontractor engaged in performing operations for a principal as a part of the same project.

EXHIBIT
C

POLICY NUMBER:

COMMERCIAL GENERAL LIABILITY
CG 20 37 07 04

THIS ENDORSEMENT CHANGES THE POLICY. PLEASE READ IT CAREFULLY.

**ADDITIONAL INSURED – OWNERS, LESSEES OR
CONTRACTORS – COMPLETED OPERATIONS**

This endorsement modifies insurance provided under the following:

COMMERCIAL GENERAL LIABILITY COVERAGE PART

SCHEDULE

Name Of Additional Insured Person(s) Or Organization(s):	Location And Description Of Completed Operations

Information required to complete this Schedule, if not shown above, will be shown in the Declarations.

Section II – Who Is An Insured is amended to include as an additional insured the person(s) or organization(s) shown in the Schedule, but only with respect to liability for "bodily injury" or "property damage" caused, in whole or in part, by "your work" at the location designated and described in the schedule of this endorsement performed for that additional insured and included in the "products-completed operations hazard".

APPENDIX C

VILLAGE OF VILLA PARK ORDINANCE 3733

NOT FOR BID

AN ORDINANCE OF THE VILLAGE OF VILLA PARK, DUPAGE COUNTY, ILLINOIS AMENDING THE REQUIREMENTS OF BIDDERS FOR CONSTRUCTION PROJECTS

WHEREAS, the Village of Villa Park (the “*Village*”) is a duly organized and validly existing non home-rule municipality created in accordance with the Constitution of the State of Illinois of 1970 and the laws of the State; and,

WHEREAS, section 8-9-1 of the Illinois Municipal Code (65 ILCS 5/8-9-2) allows the Village to require competitive bidding after advertising for bids in the manner prescribed by ordinance; and,

WHEREAS, the President and Board of Trustees desire to adopt purchasing procedures to provide for additional requirements of bidders for construction projects to have active apprenticeship and training programs approved and registered with the United States Department of Labor’s Bureau of Apprenticeship and Training and to have bidders show three similar projects they constructed within the last five years.

NOW, THEREFORE, BE IT ORDAINED by the President and Board of Trustees of the Village of Villa Park, DuPage County, Illinois, as follows:

Section 1. That Section 2-219 of the Villa Park Municipal Code, as amended, be and is hereby amended by placing the existing text as subsection A. and adding a new subsection B. to read as follows:

“B. A responsible bidder for the construction of public works projects shall meet and submit evidence of compliance with the following requirements:

- (1) All applicable laws prerequisite to doing business in the State of Illinois,
- (2) A federal employer tax identification number or social security number,
- (3) Provision of Section 2000(e) of Chapter 21, Title 42 of the United States Code and Federal Executive Order No. 11246 as amended by Executive Order No. 11375 (known as the Equal Opportunity Employer provisions),
- (4) Certificates of insurance indicating the following coverage’s: general liability, worker’s compensation, completed operations, automobile, hazardous occupation and product liability
- (5) Compliance with all provisions of the Illinois Prevailing Wage Act, including wages, medical and hospitalization insurance and retirement for those trades covered in the Act,
- (6) The bidder and all bidder’s sub-contractors must participate in active apprenticeship and training programs approved and registered with the United States Department of Labor’s Bureau of Apprenticeship and Training for each of the trades of work contemplated under the proposed contract,
- (7) All contractors and sub-contractors are required to file certified payrolls as specified in Illinois Pubic Act 94-0515, and follow all provisions of the Employee Classification Act (820 ILCS 185/1 et seq.), and

(8) All bidders must provide three (3) projects of a similar nature constructed in the immediate past five (5) years with the name, address and telephone number of the contact person having knowledge of the project along with three (3) references (name, address, and telephone number) with knowledge of the integrity and business practices of the bidder.”

Section 2. This Ordinance shall be in full force and effect upon its passage, approval, and publication as provided by law.

Passed this 11 day of February, 2013.

AYES: ALL

NAYS: Aiello Bulthuis

ABSENT: _____

Approved this 11 day of February, 2013.



Village President

Attest:

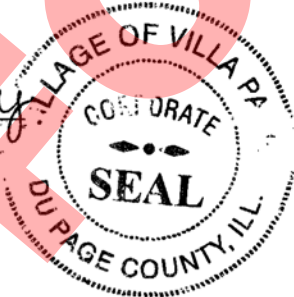
Village Clerk



Published in pamphlet form:

2-11, 2013

NOT A BID