



VILLAGE OF VILLA PARK

CONTRACT DOCUMENTS

FOR

CENTRAL BOULEVARD IMPROVEMENTS

MARCH 3, 2017

PREPARED BY

rjngroup

Excellence through Ownership

200 West Front Street
Wheaton, Illinois 60187
(630) 682-4700
www.RJN.com

NOT FOR BID

**ADVERTISEMENT FOR BIDS
VILLAGE OF VILLA PARK
FRIDAY, MARCH 10, 2017**

PROJECT: CENTRAL BOULEVARD IMPROVEMENTS

The project consists of the separation of combined sewers and the reconstruction and resurfacing on various streets which includes installation of new storm sewers, manholes, inlets and catch basins, hot-mix asphalt (HMA) pavement reconstruction, curb and gutter, driveway, and sidewalk removal and replacement. This project will include approximately 1,220 linear feet of storm sewers. The combined length of road improvements is 2,880 feet. The pavement reconstruction areas will be composed of 2" HMA surface course and 4" HMA binder course supported on a 6" aggregate base course with geotechnical fabric. In addition, there will be sidewalk replacement, curb and gutter replacement, driveway reconstruction, drainage and utility improvements, pavement markings, erosion & sediment control, and restoration and other related and incidental work.

BID DEADLINE: TUESDAY, MARCH 28, 2017 10:00 A.M. LOCAL TIME

The Village reserves the right to extend the Bid Deadline from this date and time to accept Bids submitted after the Bid Deadline, as the Village, in its sole discretion, determines is in the best interest of the Village.

NOTICE: Separate sealed proposals for the **CENTRAL BOULEVARD IMPROVEMENTS** will be received by the Village of Villa Park, Illinois, at the reception desk of the Public Works Department, 11 West Home Avenue, Villa Park, IL. 60181 until the Bid Deadline. Immediately thereafter, the proposals will be publicly opened and read aloud at the Public Works Department. Notwithstanding the foregoing, the Village reserves the right to defer, postpone, delay, or reschedule the Bid Opening for such time and to such date as the Village, in its sole discretion, determines is in the best interest of the Village.

Proposals shall be submitted in accordance with the Contract Documents prepared by the RJN Group Inc., 200 W. Front Street, Wheaton IL. 60187.

BIDDER QUALIFICATIONS: Bidders, in submitting a Bid, shall comply with all applicable Federal, State and local laws and requirements; shall provide documentation of that compliance in accordance with the requirements of the Contract Documents or requested by the Village; and, in submitting a Bid, Bidders affirm that they are qualified under all applicable laws and requirements to do so, and agree to be bound by the determination of the Village as to Bidder's compliance and qualifications.

BID SECURITY: Bid security in the amount of not less than five percent (5%) of the Bid shall accompany each Bid in accordance with the Bidding Documents.

CONTRACT SECURITY: The Bidder to whom a Contract is awarded shall be required to furnish both a Performance Bond and a Payment Bond acceptable to the Village for one-hundred percent (100%) of the Contract Price, in accordance with the requirements of the Contract Documents.

RIGHTS RESERVED: The Village reserves the right to reject any and all Bids, to waive any informalities or technicalities in bidding, and to accept the Bid which best serves the interests of the Village. The Village shall, in its sole discretion, determine what does or does not contribute an informality or technicality, and, in submitting a Bid, Bidder agrees to be bound by that determination.

WAGE RATES: The CONTRACTOR shall be required to pay not less than the prevailing wage rates on the project established by the Village. Copies of these wage rates are on file in the office of the Public Works Department and incorporated in the Contract Documents.

CONTRACT DOCUMENTS: The Bidding Documents are on file for inspection at the office of the Village of Villa Park Public Works Department, 11 West Home Avenue, Villa Park, Illinois, 60181 and may also be obtained from the office listed above for a non-refundable fee of twenty dollars (\$20.00). Payments shall be made in cash or by check made payable to the "Village of Villa Park". A "not-for-bid" version of the bidding documents will also be available on the project page on the Village's website. This version is for informational purposes only, and may not be used for the preparation or submittal of a bid.

**PUBLISHED BY AUTHORITY OF THE VILLAGE OF VILLA PARK, ILLINOIS,
DU PAGE COUNTY.**

BY:

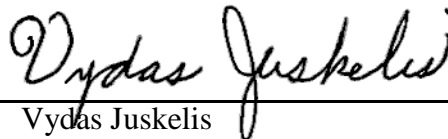

Vydas Juskelis
Director of Public Works



Illinois Department of Transportation

Local Public Agency Formal Contract Proposal

PROPOSAL SUBMITTED BY		
Contractor's Name		
Street	P.O. Box	
City	State	Zip Code

STATE OF ILLINOIS

COUNTY OF DUPAGE
 VILLAGE OF VILLA PARK
 (Name of City, Village, Town or Road District)

FOR THE IMPROVEMENT OF

STREET NAME OR ROUTE NO. CENTRAL BOULEVARD IMPROVEMENTS
 SECTION NO. N.A.
 TYPES OF FUNDS LOCAL FUNDING

SPECIFICATIONS (required)

PLANS (required)

NOT FOR BID

Note: All proposal documents, including Proposal Guaranty Checks or Proposal Bid Bonds, should be stapled together to prevent loss when bids are processed.

NOT FOR BID

RETURN WITH BID

NOTICE TO BIDDERS

County DUPAGE
Local Public Agency VILLA PARK
Section Number N.A.
Route VARIOUS

Sealed proposals for the improvement described below will be received at the office of Villa Park Public Works Dep,
11 West Home Avenue, Villa Park, IL 60181 until 10:00 AM on March 28, 2017

Sealed proposals will be opened and read publicly at the office of Villa Park Public Works Dep
11 West Home Avenue, Villa Park, IL 60181 at 10:00 AM on March 28, 2017

DESCRIPTION OF WORK

Name Central Boulevard Improvements Length: 2880.00 feet (0.55 miles)
Location Central Boulevard, Myrtle Avenue and Cortesi Avenue
Proposed Improvement Separation of combined sewers, reconstruction and resurfacing on various streets including:
storm sewers, manholes, inlets, catch basins, HMA reconstruction and resurfacing, curb & gutter replacement, etc.

1. Plans and proposal forms will be available in the office of Villa Park Public Works Department
11 West Home Avenue, Villa Park, IL 60181, phone: 630-834-8505

2. [] Prequalification
If checked, the 2 low bidders must file within 24 hours after the letting an "Affidavit of Availability" (Form BC 57), in duplicate, showing all uncompleted contracts awarded to them and all low bids pending award for Federal, State, County, Municipal and private work. One original shall be filed with the Awarding Authority and one original with the IDOT District Office.

3. The Awarding Authority reserves the right to waive technicalities and to reject any or all proposals as provided in BLRS Special Provision for Bidding Requirements and Conditions for Contract Proposals.

4. The following BLR Forms shall be returned by the bidder to the Awarding Authority:
a. BLR 12200: Local Public Agency Formal Contract Proposal
b. BLR 12200a Schedule of Prices
c. BLR 12230: Proposal Bid Bond (if applicable)
d. BLR 12325: Apprenticeship or Training Program Certification (do not use for federally funded projects)
e. BLR 12326: Affidavit of Illinois Business Office

5. The quantities appearing in the bid schedule are approximate and are prepared for the comparison of bids. Payment to the Contractor will be made only for the actual quantities of work performed and accepted or materials furnished according to the contract. The scheduled quantities of work to be done and materials to be furnished may be increased, decreased or omitted as hereinafter provided.

6. Submission of a bid shall be conclusive assurance and warranty the bidder has examined the plans and understands all requirements for the performance of work. The bidder will be responsible for all errors in the proposal resulting from failure or neglect to conduct an in depth examination. The Awarding Authority will, in no case be responsible for any costs, expenses, losses or changes in anticipated profits resulting from such failure or neglect of the bidder.

7. The bidder shall take no advantage of any error or omission in the proposal and advertised contract.

8. If a special envelope is supplied by the Awarding Authority, each proposal should be submitted in that envelope furnished by the Awarding Agency and the blank spaces on the envelope shall be filled in correctly to clearly indicate its contents. When an envelope other than the special one furnished by the Awarding Authority is used, it shall be marked to clearly indicate its contents. When sent by mail, the sealed proposal shall be addressed to the Awarding Authority at the address and in care of the official in whose office the bids are to be received. All proposals shall be filed prior to the time and at the place specified in the Notice to Bidders. Proposals received after the time specified will be returned to the bidder unopened.

9. Permission will be given to a bidder to withdraw a proposal if the bidder makes the request in writing or in person before the time for opening proposals.

NOT FOR BID

RETURN WITH BID

PROPOSAL

County DUPAGE
Local Public Agency VILLA PARK
Section Number N.A.
Route VARIOUS

1. Proposal of
for the improvement of the above section by the construction of storm sewers, manholes, inlets and catch basins, hot-mix asphalt (HMA) pavement reconstruction and resurfacing, curb and gutter, driveway, and sidewalk removal and replacement,

a total distance of 2880.00 feet, of which a distance of 2880.00 feet, (0.55 miles) are to be improved.

2. The plans for the proposed work are those prepared by RJN Group, 200 West Front St, Wheaton, IL 60187 and approved by the Department of Transportation on N.A.

3. The specifications referred to herein are those prepared by the Department of Transportation and designated as "Standard Specifications for Road and Bridge Construction" and the "Supplemental Specifications and Recurring Special Provisions" thereto, adopted and in effect on the date of invitation for bids.

4. The undersigned agrees to accept, as part of the contract, the applicable Special Provisions indicated on the "Check Sheet for Recurring Special Provisions" contained in this proposal.

5. The undersigned agrees to complete the work within 90 calendar days. N.A. unless additional time is granted in accordance with the specifications.

6. A proposal guaranty in the proper amount, as specified in BLRS Special Provision for Bidding Requirements and Conditions for Contract Proposals, will be required. Bid Bonds will be allowed as a proposal guaranty. Accompanying this proposal is either a bid bond if allowed, on Department form BLR 12230 or a proposal guaranty check, complying with the specifications, made payable to:

Village Treasurer of Villa Park

The amount of the check is 5% of Bid = ()

7. In the event that one proposal guaranty check is intended to cover two or more proposals, the amount must be equal to the sum of the proposal guaranties, which would be required for each individual proposal. If the proposal guaranty check is placed in another proposal, it will be found in the proposal for: Section Number Not Applicable

8. The successful bidder at the time of execution of the contract will be required to deposit a contract bond for the full amount of the award. When a contract bond is not required, the proposal guaranty check will be held in lieu thereof. If this proposal is accepted and the undersigned fails to execute a contract and contract bond as required, it is hereby agreed that the Bid Bond or check shall be forfeited to the Awarding Authority.

9. Each pay item should have a unit price and a total price. If no total price is shown or if there is a discrepancy between the product of the unit price multiplied by the quantity, the unit price shall govern. If a unit price is omitted, the total price will be divided by the quantity in order to establish a unit price.

10. A bid will be declared unacceptable if neither a unit price nor a total price is shown.

11. The undersigned submits herewith the schedule of prices on BLR 12200a covering the work to be performed under this contract.

12. The undersigned further agrees that if awarded the contract for the sections contained in the combinations on BLR 12200a, the work shall be in accordance with the requirements of each individual proposal for the multiple bid specified in the Schedule for Multiple Bids below.

NOT FOR BID

RETURN WITH BID

SCHEDULE OF PRICES

County DUPAGE
 Local Public Agency VILLAGE OF VILLA PARK
 Section N.A
 Route VARIOUS

Schedule for Single Bid

(For complete information covering these items, see plans and specifications)

Bidder's Proposal for making Entire Improvements

Item No.	Items	Unit	Quantity	Unit Price	Total
1	EARTH EXCAVATION	CU YD	1,000		
2	PAVEMENT REMOVAL	SQ YD	5,950		
3	REMOVAL AND DISPOSAL OF UNSUITABLE MATERIAL	CU YD	321		
4	POROUS GRANULAR EMBANKMENT	CU YD	321		
5	COMBINATION CURB AND GUTTER REMOVAL	FOOT	5,500		
6	SIDEWALK REMOVAL	SQ FT	5,000		
7	DRIVEWAY PAVEMENT REMOVAL	SQ YD	975		
8	HOT-MIX ASPHALT SURFACE REMOVAL (VARIABLE DEPTH)	SQ YD	1,175		
9	HOT-MIX ASPHALT SURFACE REMOVAL - BUTT JOINT	SQ YD	400		
10	REMOVAL AND DISPOSAL OF REGULATED SUBSTANCES	CU YD	321		
11	FRAMES & GRATES TO BE ADJUSTED	EACH	5		
12	STRUCTURES TO BE RECONSTRUCTED	EACH	9		
13	FRAMES & LIDS	EACH	4		
14	REMOVING STRUCTURES	EACH	4		
15	CATCH BASINS, TYPE A, 4' DIAMETER, TYPE 11 FRAME AND GRATE	EACH	12		
16	INLETS, TYPE A, TYPE 11 FRAME AND GRATE	EACH	2		
17	INLETS, TYPE A, TYPE 1 FRAME AND GRATE	EACH	1		
18	STORM SEWERS, PVC, SDR 26, ASTM 2241, 6"	FOOT	80		

NOT FOR BID

RETURN WITH BID

Bidder's Proposal for making Entire Improvements

Item No.	Items	Unit	Quantity	Unit Price	Total
19	STORM SEWERS, PVC, SDR 26, ASTM 2241, 12"	FOOT	315		
20	STORM SEWERS, PVC, SDR 26, ASTM 2241, 18"	FOOT	20		
21	COMB CONCRETE CURB AND GUTTER TY B-6.12	FOOT	5,500		
22	CONCRETE BARRIER CURB, TYPE B	FOOT	100		
23	PCC SIDEWALK, 5"	SQ FT	5,000		
24	DETECTABLE WARNINGS	SQ FT	275		
25	PCC DRIVEWAY PAVEMENT, 6"	SQ YD	150		
26	PCC DRIVEWAY PAVEMENT, 8"	SQ YD	230		
27	PROTECTIVE COAT	SQ YD	2,000		
28	GEOTECHNICAL FABRIC FOR GROUND STABILIZATION	SQ YD	7,150		
29	AGGREGATE BASE COURSE, TYPE B, 6"	SQ YD	6,585		
30	AGGREGATE FOR TEMPORARY ACCESS	EACH	10		
31	BITUMINOUS MATERIALS (TACK COAT)	POUND	16,850		
32	HOT-MIX ASPHALT DRIVEWAY PAVEMENT, 4"	SQ YD	655		
33	HOT-MIX ASPHALT DRIVEWAY PAVEMENT, 6"	SQ YD	25		
34	CLASS D PATCHES, TYPE I-IV, 6"	SQ YD	175		
35	LEVELING BINDER (MACHINE METHOD), N50	TON	75		
36	HOT-MIX ASPHALT BINDER COURSE, IL-19.0, N50	TON	1,450		
37	HOT-MIX ASPHALT SURFACE COURSE, MIX D, N50	TON	950		
38	TOPSOIL FURNISH AND PLACE, 4"	SQ YD	3,250		
39	SODDING	SQ YD	3,250		
40	THERMOPLASTIC PAVEMENT MARKING - LINE 4"	FOOT	50		
41	THERMOPLASTIC PAVEMENT MARKING - LINE 24"	FOOT	155		
42	INLET FILTERS	EACH	22		
43	TRENCH BACKFILL	CU YD	800		

NOT FOR BID

RETURN WITH BID

Bidder's Proposal for making Entire Improvements

Item No.	Items	Unit	Quantity	Unit Price	Total
44	STORM SEWERS, RCP, CL IV, ASTM C76, 12"	FOOT	329		
45	STORM SEWERS, RCP, CL IV, ASTM C76, 24"	FOOT	467		
46	24" MANHOLE CONNECTION (CORE INTO EXISTING)	EACH	1		
47	STORM MANHOLES, TYPE A, 4' DIAMETER, TYPE 1 FRAME, CLOSED LID	EACH	5		
48	DOGHOUSE STORM MANHOLES, TYPE A, 7' DIAMETER, TYPE 1 FRAME, CLOSED LID	EACH	1		
49	SANITARY MANHOLES, TYPE A, 4' DIAMETER, TYPE 1 FRAME, CLOSED LID	EACH	1		
50	ADJUSTING SANITARY SEWERS, 8-INCH DIAMETER OR LESS	FOOT	30		
51	ADJUSTING WATERMAIN, 6"	FOOT	60		
52	ADJUSTING WATER SERVICES LINES	FOOT	40		
53	WATER SERVICE REPLACEMENT	EACH	3		
54	VALVE VAULTS, TYPE A, 4' DIAMETER, TYPE 1 FRAME, CLOSED LID	EACH	5		
55	WATER VALVES, 6"	EACH	5		
56	CONNECTION TO EXISTING WATER MAIN, 6"	EACH	1		
57	FIRE HYDRANTS TO BE REMOVED	EACH	2		
58	FIRE HYDRANTS WITH AUXILIARY VALVE AND VALVE BOX	EACH	2		
59	WATER USAGE DEDUCTION	TGAL	100	-\$8.85	-\$885.00
60	WATER USAGE CREDIT	TGAL	100	\$8.85	\$885.00
61	PERIMETER EROSION BARRIER	FOOT	300		
62	PRE-CONSTRUCTION VIDEO RECORDING	L SUM	1		
63	CONSTRUCTION LAYOUT	L SUM	1		
64	TRAFFIC CONTROL AND PROTECTION	L SUM	1		
65	CONTINGENCY ALLOWANCE	UNIT	30,000	\$1.00	\$30,000.00

NOT FOR BID

CONTRACTOR CERTIFICATIONS

County	<u>DUPAGE</u>
Local Public Agency	<u>VILLA PARK</u>
Section Number	<u>N.A</u>
Route	<u>VARIOUS</u>

The certifications hereinafter made by the bidder are each a material representation of fact upon which reliance is placed should the Department enter into the contract with the bidder.

- Debt Delinquency.** The bidder or contractor or subcontractor, respectively, certifies that it is not delinquent in the payment of any tax administered by the Department of Revenue unless the individual or other entity is contesting, in accordance with the procedures established by the appropriate revenue Act, its liability for the tax or the amount of tax. Making a false statement voids the contract and allows the Department to recover all amounts paid to the individual or entity under the contract in a civil action.
- Bid-Rigging or Bid Rotating.** The bidder or contractor or subcontractor, respectively, certifies that it is not barred from contracting with the Department by reason of a violation of either 720 ILCS 5/33E-3 or 720 ILCS 5/33E-4.

A violation of Section 33E-3 would be represented by a conviction of the crime of bid-rigging which, in addition to Class 3 felony sentencing, provides that any person convicted of this offense or any similar offense of any state or the United States which contains the same elements as this offense shall be barred for 5 years from the date of conviction from contracting with any unit of State or local government. No corporation shall be barred from contracting with any unit of State or local government as a result of a conviction under this Section of any employee or agent of such corporation if the employee so convicted is no longer employed by the corporation and: (1) it has been finally adjudicated not guilty or (2) if it demonstrates to the governmental entity with which it seeks to contract and that entity finds that the commission of the offense was neither authorized, requested, commanded, nor performed by a director, officer or a high managerial agent in behalf of the corporation.

A violation of Section 33E-4 would be represented by a conviction of the crime of bid-rotating which, in addition to Class 2 felony sentencing, provides that any person convicted of this offense or any similar offense of any state or the United States which contains the same elements as this offense shall be permanently barred from contracting with any unit of State or local government. No corporation shall be barred from contracting with any unit of State or local government as a result of a conviction under this Section of any employee or agent of such corporation if the employee so convicted is no longer employed by the corporation and: (1) it has been finally adjudicated not guilty or (2) if it demonstrates to the governmental entity with which it seeks to contract and that entity finds that the commission of the offense was neither authorized, requested, commanded, nor performed by a director, officer or a high managerial agent in behalf of the corporation.

- Bribery.** The bidder or contractor or subcontractor, respectively, certifies that it has not been convicted of bribery or attempting to bribe an officer or employee of the State of Illinois or any unit of local government, nor has the firm made an admission of guilt of such conduct which is a matter of record, nor has an official, agent, or employee of the firm committed bribery or attempted bribery on behalf of the firm and pursuant to the direction or authorization of a responsible official of the firm.
- Interim Suspension or Suspension.** The bidder or contractor or subcontractor, respectively, certifies that it is not currently under a suspension as defined in Subpart I of Title 44 Subtitle A Chapter III Part 6 of the Illinois Administrative Code. Furthermore, if suspended prior to completion of this work, the contract or contracts executed for the completion of this work may be cancelled.

NOT FOR BID

RETURN WITH BID

SIGNATURES

County DUPAGE
Local Public Agency VILLA PARK
Section Number N.A.
Route VARIOUS

(If an individual)

Signature of Bidder _____
Business Address _____

(If a partnership)

Firm Name _____
Signed By _____
Business Address _____

Inset Names and Addressed of All Partners



(If a corporation)

Corporate Name _____
Signed By _____
President
Business Address _____

Inset Names of Officers

President _____
Secretary _____
Treasurer _____

Attest: _____
Secretary

NOT FOR BID



Route VARIOUS
County DUPAGE
Local Agency VILLA PARK
Section N.A.

RETURN WITH BID

PAPER BID BOND

WE _____ as PRINCIPAL,
and _____ as SURETY,
are held jointly, severally and firmly bound unto the above Local Agency (hereafter referred to as "LA") in the penal sum of 5% of the total bid price, or for the amount specified in the proposal documents in effect on the date of invitation for bids whichever is the lesser sum. We bind ourselves, our heirs, executors, administrators, successors, and assigns, jointly pay to the LA this sum under the conditions of this instrument.

WHEREAS THE CONDITION OF THE FOREGOING OBLIGATION IS SUCH that, the said PRINCIPAL is submitting a written proposal to the LA acting through its awarding authority for the construction of the work designated as the above section.

THEREFORE if the proposal is accepted and a contract awarded to the PRINCIPAL by the LA for the above designated section and the PRINCIPAL shall within fifteen (15) days after award enter into a formal contract, furnish surety guaranteeing the faithful performance of the work, and furnish evidence of the required insurance coverage, all as provided in the "Standard Specifications for Road and Bridge Construction" and applicable Supplemental Specifications, then this obligation shall become void; otherwise it shall remain in full force and effect.

IN THE EVENT the LA determines the PRINCIPAL has failed to enter into a formal contract in compliance with any requirements set forth in the preceding paragraph, then the LA acting through its awarding authority shall immediately be entitled to recover the full penal sum set out above, together with all court costs, all attorney fees, and any other expense of recovery.

IN TESTIMONY WHEREOF, the said PRINCIPAL and the said SURETY have caused this instrument to be signed by their respective officers this _____ day of _____

Principal

(Company Name) _____ (Company Name)
By: _____ By: _____
(Signature and Title) (Signature and Title)

(If PRINCIPLE is a joint venture of two or more contractors, the company names, and authorized signatures of each contractor must be affixed.)

Surety

(Name of Surety) _____ By: _____
(Signature of Attorney-in-Fact)

STATE OF ILLINOIS,
COUNTY OF _____

I, _____, a Notary Public in and for said county,
do hereby certify that _____

(Insert names of individuals signing on behalf of PRINCIPAL & SURETY)

who are each personally known to me to be the same persons whose names are subscribed to the foregoing instrument on behalf of PRINCIPAL and SURETY, appeared before me this day in person and acknowledged respectively, that they signed and delivered said instruments as their free and voluntary act for the uses and purposes therein set forth.

Given under my hand and notarial seal this _____ day of _____

My commission expires _____ (Notary Public)

ELECTRONIC BID BOND

[] Electronic bid bond is allowed (box must be checked by LA if electronic bid bond is allowed)

The Principal may submit an electronic bid bond, in lieu of completing the above section of the Proposal Bid Bond Form. By providing an electronic bid bond ID code and signing below, the Principal is ensuring the identified electronic bid bond has been executed and the Principal and Surety are firmly bound unto the LA under the conditions of the bid bond as shown above. (If PRINCIPAL is a joint venture of two or more contractors, an electronic bid bond ID code, company/Bidder name title and date must be affixed for each contractor in the venture.)

Electronic Bid Bond ID Code (grid)

Electronic Bid Bond ID Code

(Company/Bidder Name)

(Signature and Title)

Date

NOT FOR BID



Apprenticeship or Training Program Certification

Return with Bid

Route	VARIOUS
County	DUPAGE
Local Agency	VILLA PARK
Section	N.A.

All contractors are required to complete the following certification:

- For this contract proposal or for all groups in this deliver and install proposal.
- For the following deliver and install groups in this material proposal:

Illinois Department of Transportation policy, adopted in accordance with the provisions of the Illinois Highway Code, requires this contract to be awarded to the lowest responsive and responsible bidder. The award decision is subject to approval by the Department. In addition to all other responsibility factors, this contract or deliver and install proposal requires all bidders and all bidders' subcontractors to disclose participation in apprenticeship or training programs that are (1) approved by and registered with the United States Department of Labor's Bureau of Apprenticeship and Training, and (2) applicable to the work of the above indicated proposals or groups. Therefore, all bidders are required to complete the following certification:

- I. Except as provided in paragraph IV below, the undersigned bidder certifies that it is a participant, either as an individual or as part of a group program, in an approved apprenticeship or training program applicable to each type of work or craft that the bidder will perform with its own employees.
- II. The undersigned bidder further certifies for work to be performed by subcontract that each of its subcontractors submitted for approval either (A) is, at the time of such bid, participating in an approved, applicable apprenticeship or training program; or (B) will, prior to commencement of performance of work pursuant to this contract, establish participation in an approved apprenticeship or training program applicable to the work of the subcontract.
- III. The undersigned bidder, by inclusion in the list in the space below, certifies the official name of each program sponsor holding the Certificate of Registration for all of the types of work or crafts in which the bidder is a participant and that will be performed with the bidder's employees. Types of work or craft that will be subcontracted shall be included and listed as subcontract work. The list shall also indicate any type of work or craft job category for which there is no applicable apprenticeship or training program available.

NOT FOR BID

IV. Except for any work identified above, any bidder or subcontractor that shall perform all or part of the work of the contract or deliver and install proposal solely by individual owners, partners or members and not by employees to whom the payment of prevailing rates of wages would be required, check the following box, and identify the owner/operator workforce and positions of ownership.

The requirements of this certification and disclosure are a material part of the contract, and the contractor shall require this certification provision to be included in all approved subcontracts. The bidder is responsible for making a complete report and shall make certain that each type of work or craft job category that will be utilized on the project is accounted for and listed. The Department at any time before or after award may require the production of a copy of each applicable Certificate of Registration issued by the United States Department of Labor evidencing such participation by the contractor and any or all of its subcontractors. In order to fulfill the participation requirement, it shall not be necessary that any applicable program sponsor be currently taking or that it will take applications for apprenticeship, training or employment during the performance of the work of this contract or deliver and install proposal.

Bidder: _____

By: _____

(Signature)

Address: _____

Title: _____

NOT FOR

NOT FOR BID



Illinois Department of Transportation

Affidavit of Illinois Business Office

County DUPAGE
Local Public Agency VILLA PARK
Section Number N.A.
Route VARIOUS

State of _____)
County of _____) ss.

I, _____ of _____, _____,
(Name of Affiant) (City of Affiant) (State of Affiant)

being first duly sworn upon oath, states as follows:

1. That I am the _____ of _____ bidder.
officer or position
2. That I have personal knowledge of the facts herein stated.
3. That, if selected under this proposal, _____, will maintain a
(bidder)
business office in the State of Illinois which will be located in _____ County, Illinois.
4. That this business office will serve as the primary place of employment for any persons employed in the construction contemplated by this proposal.
5. That this Affidavit is given as a requirement of state law as provided in Section 30-22(8) of the Illinois Procurement Code.

(Signature)

(Print Name of Affiant)

This instrument was acknowledged before me on _____ day of _____, _____.

(SEAL)

(Signature of Notary Public)

NOT FOR BID



Illinois Department of Transportation

Bureau of Construction
2300 South Dirksen Parkway/Room 322
Springfield, Illinois 62764

Affidavit of Availability For the Letting of _____

Instructions: Complete this form by either typing or using black ink. "Authorization to Bid" will not be issued unless both sides of this form are completed in detail. Use additional forms as needed to list all work.

Part I. Work Under Contract

List below all work you have under contract as either a prime contractor or a subcontractor. It is required to include all pending low bids not yet awarded or rejected. In a joint venture, list only that portion of the work which is the responsibility of your company. The uncompleted dollar value is to be based upon the most recent engineer's or owners estimate, and must include work subcontracted to others. If no work is contracted, show **NONE**.

	1	2	3	4	Awards Pending	
Contract Number						
Contract With						
Estimated Completion Date						
Total Contract Price						Accumulated Totals
Uncompleted Dollar Value if Firm is the Prime Contractor						
Uncompleted Dollar Value if Firm is the Subcontractor						
Total Value of All Work						

Part II. Awards Pending and Uncompleted Work to be done with your own forces.

List below the uncompleted dollar value of work for each contract and awards pending to be completed with your own forces. All work subcontracted to others will be listed on the reverse of this form. In a joint venture, list only that portion of the work to be done by your company. If no work is contracted, show **NONE**.

						Accumulated Totals
Earthwork						
Portland Cement Concrete Paving						
HMA Plant Mix						
HMA Paving						
Clean & Seal Cracks/Joints						
Aggregate Bases & Surfaces						
Highway, R.R. and Waterway Structures						
Drainage						
Electrical						
Cover and Seal Coats						
Concrete Construction						
Landscaping						
Fencing						
Guardrail						
Painting						
Signing						
Cold Milling, Planning & Rotomilling						
Demolition						
Pavement Markings (Paint)						
Other Construction (List)						
						\$ 0.00
Totals						

Disclosure of this information is **REQUIRED** to accomplish the statutory purpose as outlined in the "Illinois Procurement Code." Failure to comply will result in non-issuance of an "Authorization To Bid." This form has been approved by the State Forms Management Center.

NOT FOR BID

Part III. Work Subcontracted to Others.

For each contract described in Part I, list all the work you have subcontracted to others.

	1	2	3	4	Awards Pending
Subcontractor					
Type of Work					
Subcontract Price					
Amount Uncompleted					
Subcontractor					
Type of Work					
Subcontract Price					
Amount Uncompleted					
Subcontractor					
Type of Work					
Subcontract Price					
Amount Uncompleted					
Subcontractor					
Type of Work					
Subcontract Price					
Amount Uncompleted					
Subcontractor					
Type of Work					
Subcontract Price					
Amount Uncompleted					
Subcontractor					
Type of Work					
Subcontract Price					
Amount Uncompleted					
Total Uncompleted					

I, being duly sworn, do hereby declare that this affidavit is a true and correct statement relating to ALL uncompleted contracts of the undersigned for Federal, State, County, City and private work, including ALL subcontract work, ALL pending low bids not yet awarded or rejected and ALL estimated completion dates.

Subscribed and sworn to before me
 this _____ day of _____, _____ Type or Print Name _____
 _____ Officer or Director _____ Title

Signed _____

 Notary Public

My commission expires _____

(Notary Seal)

Company _____

Address _____

NOT FOR BID



PROPOSAL SUBMITTED BY		
Contractor's Name		
Street	P.O. Box	
City	State	Zip Code

STATE OF ILLINOIS

COUNTY DUPAGE
 VILLAGE OF VILLA PARK
(Name of City, Village, Town or Road District)

FOR THE IMPROVEMENT OF
 STREET NAME OR ROUTE CENTRAL BOULEVARD IMPROVEMENTS
 SECTION NO. N.A.
 TYPES OF FUNDS LOCAL FUNDING

- SPECIFICATIONS (required) PLANS (required) CONTRACT BOND (required)

NOT FOR BLD

NOT FOR BID

County DUPAGE
Local Public Agency VILLA PARK
Section Number N.A.
Route VARIOUS

1. THIS AGREEMENT, made and concluded the _____ day of _____, _____
Month and Year
between the Village of Villa Park
acting by and through its Board of Trustees known as the party of the first part, and
_____ his/their executors, administrators, successors or assigns,
known as the party of the second part.
2. Witnesseth: That for and in consideration of the payments and agreements mentioned in the Proposal hereto attached, to be made and performed by the party of the first part, and according to the terms expressed in the Bond referring to these presents, the party of the second part agrees with said party of the first part at his/their own proper cost and expense to do all the work, furnish all materials and all labor necessary to complete the work in accordance with the plans and specifications hereinafter described, and in full compliance with all of the terms of this agreement and the requirements of the Engineer under it.
3. And it is also understood and agreed that the LPA Formal Contract Proposal, Special Provisions, Affidavit of Illinois Business Office, Apprenticeship or Training Program Certification, and Contract Bond hereto attached, and the Plans for Section VARIOUS ROUTE, in the Village of Villa Park, approved by the Village of Villa Park on _____, are essential documents of this
Date
contract and are a part hereof.
4. IN WITNESS WHEREOF, The said parties have executed these presents on the date above mentioned.

Attest: _____ The Village of Villa Park
_____ Village Clerk By _____
Party of the First Part

(Seal) _____
(If a Corporation)
Corporate Name _____
By _____
President Party of the Second Part
(If a Co-Partnership)

Attest: _____
Secretary

Partners doing Business under the firm name of

Party of the Second Part
(If an individual)

Party of the Second Part

NOT FOR BID



Route VARIOUS
 County DUPAGE
 Local Agency VILLA PARK
 Section N.A.

We , _____

a/an) Individual Co-partnership Corporation organized under the laws of the State of _____ ,
as PRINCIPAL, and _____

_____ as SURETY,

are held and firmly bound unto the above Local Agency (hereafter referred to as "LA") in the penal sum of _____

_____ Dollars (_____), lawful money of the United States, well and truly to be paid unto said LA, for the payment of which we bind ourselves, our heirs, executors, administrators, successors, jointly to pay to the LA this sum under the conditions of this instrument.

WHEREAS THE CONDITION OF THE FOREGOING OBLIGATION IS SUCH that, the said Principal has entered into a written contract with the LA acting through its awarding authority for the construction of work on the above section, which contract is hereby referred to and made a part hereof, as if written herein at length, and whereby the said Principal has promised and agreed to perform said work in accordance with the terms of said contract, and has promised to pay all sums of money due for any labor, materials, apparatus, fixtures or machinery furnished to such Principal for the purpose of performing such work and has further agreed to pay all direct and indirect damages to any person, firm, company or corporation suffered or sustained on account of the performance of such work during the time thereof and until such work is completed and accepted; and has further agreed that this bond shall inure to the benefit of any person, firm, company or corporation to whom any money may be due from the Principal, subcontractor or otherwise for any such labor, materials, apparatus, fixtures or machinery so furnished and that suit may be maintained on such bond by any such person, firm, company or corporation for the recovery of any such money.

NOW THEREFORE, if the said Principal shall well and truly perform said work in accordance with the terms of said contract, and shall pay all sums of money due or to become due for any labor, materials, apparatus, fixtures or machinery furnished to him for the purpose of constructing such work, and shall commence and complete the work within the time prescribed in said contract, and shall pay and discharge all damages, direct and indirect, that may be suffered or sustained on account of such work during the time of the performance thereof and until the said work shall have been accepted, and shall hold the LA and its awarding authority harmless on account of any such damages and shall in all respects fully and faithfully comply with all the provisions, conditions and requirements of said contract, then this obligation to be void; otherwise to remain in full force and effect.

NOT FOR BID

IN TESTIMONY WHEREOF, the said PRINCIPAL and the said SURETY have caused this instrument to be signed by their respective officers this _____ day of _____ A.D. _____

PRINCIPAL

(Company Name)

(Company Name)

By: _____
(Signature & Title)

By: _____
(Signature & Title)

Attest: _____
(Signature & Title)

Attest: _____
(Signature & Title)

(If PRINCIPAL is a joint venture of two or more contractors, the company names and authorized signature of each contractor must be affixed.)

STATE OF ILLINOIS,
COUNTY OF _____

I, _____, a Notary Public in and for said county, do hereby certify that

(Insert names of individuals signing on behalf or PRINCIPAL)

who are each personally known to me to be the same persons whose names are subscribed to the foregoing instrument on behalf of PRINCIPAL, appeared before me this day in person and acknowledged respectively, that they signed and delivered said instrument as their free and voluntary act for the uses and purposes therein set forth.

Given under my hand and notarial seal this _____ day of _____ A.D. _____

My commission expires _____ Notary Public **(SEAL)**

SURETY

(Name of Surety)

By: _____
(Signature of Attorney-in-Fact)

STATE OF ILLINOIS. **(SEAL)**
COUNTY OF _____

I, _____, a Notary Public in and for said county, do hereby certify that

(Insert names of individuals signing on behalf or SURETY)

who are each personally known to me to be the same persons whose names are subscribed to the foregoing instrument on behalf of SURETY, appeared before me this day in person and acknowledged respectively, that they signed and delivered said instrument as their free and voluntary act for the uses and purposes therein set forth.

Given under my hand and notarial seal this _____ day of _____ A.D. _____

My commission expires _____ Notary Public **(SEAL)**

Approved this _____ day of _____, A.D. _____

Attest: _____

Village of Villa Park
(Awarding Authority)

Village Clerk

(President)

NOT FOR BID



VILLAGE OF VILLA PARK

CONTRACT DOCUMENTS

FOR

CENTRAL BOULEVARD IMPROVEMENTS

SPECIAL PROVISIONS

NOT FOR BID

INDEX OF SPECIAL PROVISIONS

TITLE	PAGE NO.
DEFINITIONS	5
LOCATION OF PROJECT	5
DESCRIPTION OF PROJECT	6
QUALIFICATIONS OF BIDDERS.....	7
INCREASED OR DECREASED QUANTITIES.....	9
SUBCONTRACTORS.....	9
COMPLETION OF PROJECT.....	10
WORKING HOURS	10
HOLIDAYS.....	11
SPECIAL EVENTS	11
PUBLIC CONVENIENCE AND SAFETY (D-1).....	12
INSURANCE.....	12
DUPAGE COUNTY HIGHWAY PERMIT.....	13
MAINTENANCE GUARANTEE.....	13
MOBILIZATION.....	14
CONSTRUCTION SAFETY AND HEALTH STANDARDS	14
MAINTENANCE OF ROADWAYS	14
KEEPING ROADS OPEN TO TRAFFIC.....	14
RESPONSIBILITY FOR VANDALISM.....	15
SHOP DRAWINGS AND SUBMITTALS.....	15
CLEAN UP.....	16
BRACING AND SHEETING	16
PIPE BEDDING	16
SEWER FLOW CONTROL	16
ADJUSTING RINGS	18
FRAMES, GRATES AND LIDS	18
DATE OF MANUFACTURE	19
SALVAGE AND DISPOSAL OF EXISTING CASTINGS.....	20
CONCRETE WASHOUT FACILITY	20
USE OF FIRE HYDRANTS.....	21

**CENTRAL BOULEVARD IMPROVEMENTS
VILLAGE OF VILLA PARK**

PROTECTION OF EXISTING DRAINAGE FACILITIES DURING CONSTRUCTION.....	22
ITEM #1: EARTH EXCAVATION.....	23
ITEM #2: PAVEMENT REMOVAL.....	24
ITEM #3: REMOVAL AND DISPOSAL OF UNSUITABLE MATERIAL	25
ITEM #4: POROUS GRANULAR EMBANKMENT	25
ITEM #5: COMBINATION CURB AND GUTTER REMOVAL	26
ITEM #6: SIDEWALK REMOVAL.....	26
ITEM #7: DRIVEWAY PAVEMENT REMOVAL.....	27
ITEM #8: HOT-MIX ASPHALT SURFACE REMOVAL – (VARIABLE DEPTH).....	27
ITEM #9: HOT-MIX ASPHALT SURFACE REMOVAL – BUTT JOINT.....	28
ITEM #10: REMOVAL AND DISPOSAL OF REGULATED SUBSTANCES.....	29
ITEM #11: FRAMES AND GRATES TO BE ADJUSTED	29
ITEM #12: STRUCTURE TO BE RECONSTRUCTED.....	30
ITEM #13: FRAMES AND LIDS	31
ITEM #14: REMOVING STRUCTURES.....	31
ITEM #15: CATCH BASINS, TYPE A, 4' DIAMETER, TYPE 11 FRAME AND GRATE.....	31
ITEM #16 & 17: INLETS, TYPE A	32
ITEM #18 TO 20: STORM SEWERS, PVC, SDR 26, ASTM 2241	33
ITEM #21: COMBINATION CONCRETE CURB AND GUTTER, TYPE B-6.12	34
ITEM #22: CONCRETE BARRIER CURB, TYPE B	35
ITEM #23: PORTLAND CEMENT CONCRETE SIDEWALK, 5"	36
ITEM #24: DETECTABLE WARNINGS.....	36
ITEM #25: PORTLAND CEMENT CONCRETE DRIVEWAY PAVEMENT, 6"	37
ITEM #26 PORTLAND CEMENT CONCRETE DRIVEWAY PAVEMENT, 8"	37
ITEM #28: GEOTECHNICAL FABRIC FOR GROUND STABILIZATION	37
ITEM #30: AGGREGATE FOR TEMPORARY ACCESS.....	38
ITEM #31: BITUMINOUS MATERIALS (TACK COAT).....	38
ITEM #32: HOT-MIX ASPHALT DRIVEWAY PAVEMENT, 4"	39
ITEM #33: HOT-MIX ASPHALT DRIVEWAY PAVEMENT, 6"	39
ITEM #34: CLASS D PATCHES, TYPE I-IV, 6"	40
ITEM #37: HOT-MIX ASPHALT SURFACE COURSE, MIX D, N50	40
ITEM #38: TOPSOIL FURNISH AND PLACE, 4"	41
ITEM #39: SODDING.....	41

**CENTRAL BOULEVARD IMPROVEMENTS
VILLAGE OF VILLA PARK**

ITEM #42: INLET FILTERS.....	42
ITEM #43: TRENCH BACKFILL.....	43
ITEM #44 & 45: STORM SEWERS, RCP, CL IV, ASTM C76.....	43
ITEM #46: 24" MANHOLE CONNECTION (CORE INTO EXISTING).....	44
ITEM #47: STORM MANHOLES, TYPE A, 4' DIAMETER, TYPE 1 FRAME, CLOSED LID.....	44
ITEM #48: DOGHOUSE STORM MANHOLES, TYPE A, 7' DIAMETER, TYPE 1 FRAME, CLOSED LID	45
ITEM #49: SANITARY MANHOLES, TYPE A, 4' DIAMETER, TYPE 1 FRAME, CLOSED LID.....	45
ITEM #50: ADJUSTING SANITARY SEWERS, 8" DIAMETER OR LESS.....	47
ITEM #51: ADJUSTING WATERMAIN, 6".....	47
ITEM #52: ADJUSTING WATER SERVICE LINES.....	48
ITEM #53: WATER SERVICE REPLACEMENT.....	49
ITEM #54: VALVE VAULTS, TYPE A, 4' DIAMETER, TYPE 1 FRAME, CLOSED LID	50
ITEM #55: WATER VALVES.....	50
ITEM #56: CONNECTION TO EXISTING WATER MAIN.....	51
ITEM #57: FIRE HYDRANTS TO BE REMOVED	52
ITEM #58: FIRE HYDRANT WITH AUXILIARY VALVE AND VALVE BOX	53
ITEM #59: WATER USAGE DEDUCTION	56
ITEM #60: WATER USAGE CREDIT.....	56
ITEM #62: PRE-CONSTRUCTION VIDEO RECORDING.....	57
ITEM #63: CONSTRUCTION LAYOUT.....	59
ITEM #64: TRAFFIC CONTROL AND PROTECTION.....	60
ITEM #65: CONTINGENCY ALLOWANCE	61

APPENDIX 1:

- INDEX FOR SUPPLEMENTAL AND RECURRING SPECIAL PROVISIONS
- CHECK SHEET FOR RECURRING SPECIAL PROVISIONS
- CHECK SHEET FOR LOCAL & STREETS RECURRING SPECIAL PROVISIONS
- BDE SPECIAL PROVISIONS
- LOCAL ROADS SPECIAL PROVISION FOR INSURANCE
- DUPAGE COUNTY PREVAILING WAGES

APPENDIX 2:

- IDOT STANDARD DETAILS

APPENDIX 3:

**CENTRAL BOULEVARD IMPROVEMENTS
VILLAGE OF VILLA PARK**

- ORDINANCE AMENDING THE REQUIREMENTS OF BIDDERS FOR CONSTRUCTION PROJECTS
- IRMA CONTRACTUALINSURANCE GUIDELINES

APPENDIX 4:

- IEPA NOTICE OF INTENT (NOI)
- STORM WATER POLLUTION PREVENTION PLAN
- IEPA NOTICE OF TERMINATION (NOT)
- DUPAGE COUNTY - APPLICATION FOR HIGHWAY PERMIT
- HIGHWAY PERMIT INSURANCE REQUIREMENTS

APPENDIX 5:

- GEOTECHNICAL REPORT
- LPC 662 CCDD CERTIFICATION (STREET NAMES)
- LPC 663 CCDD CERTIFICATION (STREET NAMES)
- BLUFF CITY MATERIALS PRE APPROVAL LETTER

NOT FOR BID

**PROJECT SPECIAL PROVISIONS
FOR
CENTRAL BOULEVARD IMPROVEMENTS**

The following Special Provisions supplement the “Standard Specifications for Road and Bridge Construction”, adopted April 1, 2016 (referred to hereinafter as the Standard Specifications); the “Supplemental Specifications and Recurring Special Provisions”, adopted January 1, 2017; the latest edition of the “Illinois Manual on Uniform Traffic Control Devices For Streets and Highways” (IMUTCD); and the “Standard Specifications for Water and Sewer Construction in Illinois”, 7th Edition, 2014 (referred to hereinafter as the Water and Sewer Specifications). In case of conflict with any part, or parts, of said Specifications, the said Special Provisions shall take precedence and shall govern. Where no conflict exists, the said Specifications shall apply to this Contract as if repeated in their entirety herein.

DEFINITIONS

Contractor. The individual, firm, partnership, joint venture, or corporation contracting with the Village of Villa Park for performance of the prescribed work.

Department, Owner or Village. The Village of Villa Park, DuPage County, Illinois.

Engineer. The Resident Engineer who is the authorized representative of the Village of Villa Park in immediate charge of the engineering details of a construction project.

LOCATION OF PROJECT

The proposed work is officially known as the “Central Boulevard Improvements”. The project involves various improvements in multiple locations throughout the Village of Villa Park, County of DuPage, State of Illinois:

Street Improvement	Starting Limit	Ending Limit
CENTRAL BOULEVARD	VILLA AVENUE	CORNELL AVENUE
MYRTLE AVENUE	KENILWORTH AVENUE	CENTRAL BOULEVARD
CORTESI AVENUE	KENILWORTH AVENUE	CENTRAL BOULEVARD

DESCRIPTION OF PROJECT

The project consists of the separation of combined sewers and the reconstruction and resurfacing on various streets which includes installation of new storm sewers, manholes, inlets and catch basins, hot-mix asphalt (HMA) pavement reconstruction, curb and gutter, driveway, and sidewalk removal and replacement, drainage and utility improvements, pavement markings, erosion & sediment control, and restoration and other related and incidental work.

This project will include approximately 1,220 linear feet of storm sewers. The combined length of road improvements is 2,880 feet. The pavement reconstruction areas will be composed of 2" HMA surface course and 4" HMA binder course supported on a 6" aggregate base course with geotechnical fabric.

NOT FOR BID

GENERAL SPECIAL PROVISIONS

QUALIFICATIONS OF BIDDERS

Bidders will comply with all applicable Federal, State and local laws and requirements, and will further meet the qualifications prescribed in this and other applicable portions of these provisions.

Bidder, in submitting a Bid, certifies that Bidder is in compliance with all applicable Federal, State and local laws and requirements, and that Bidder further meets the qualifications prescribed in this and other applicable portions of these provisions. Engineer's determination as to the compliance and qualifications of the Bidder will be final, and Bidder, in submitting a Bid, agrees to be bound by that determination.

Bidder, in submitting a Bid, certifies that Bidder is in compliance with the following requirements and qualifications. Bidder further certifies that Bidder is able to provide written evidence of Bidder's compliance with the following requirements and qualifications. Bidder shall, upon request by Engineer, submit such written evidence within five (5) calendar days of the Engineer's request, as well as any other written evidence which Engineer may deem necessary for the purpose of evaluating Bidder's qualifications.

- (a) Bidder shall be qualified to do business in the State of Illinois.
- (b) Bidder shall possess either a valid Federal Employer Tax Identification Number (FEIN) or a valid Social Security Number (SSN).
- (c) Bidder shall be able to provide a street address and description of the Bidder's place of business, and the mailing address of the business, if different from the street address.
- (d) Bidder shall be able to provide the number of years Bidder has been engaged in the contracting business under the present firm name, and the name of the state where incorporated.
- (e) Bidder shall be able to provide a list of the property and equipment available to the Bidder.
- (f) Bidder shall be able to provide a financial statement demonstrating that the Bidder has the financial resources to meet all obligations related to the Work.
- (g) Bidder shall maintain insurance policies with the coverages required by the Contract, and with the minimum limits of coverage required by the Contract. Bidder shall be able to provide current certificate(s) of insurance for the insurance policies held by Bidder, demonstrating that Bidder holds insurance

**CENTRAL BOULEVARD IMPROVEMENTS
VILLAGE OF VILLA PARK**

policies with the coverages required by the contract, and with the minimum limits of coverage required by the Contract.

- (h) Bidder shall have constructed a minimum of three (3) projects of a similar nature in the immediate past five (5) years. Bidder shall be able to provide a list of all projects of a similar nature constructed by Bidder in the immediate past five (5) years, which list shall contain the minimum of three (3) such projects, which list shall provide a description and the location(s) of all such projects, and shall contain the Bidder's performance record and references, as well as the names and current contact information, including addresses and telephone numbers, of persons who acted as owners' representatives for those projects and who have knowledge of those projects, and whom Bidder agrees the Village may contact for the purpose of verifying Bidder's performance and references.
- (i) Bidder shall be able to provide a list of three (3) references (name, address and telephone number) with knowledge of the integrity and business practices of the bidder. Such references may not be persons who have been employed by Bidder as employees.
- (j) Bidder shall be able to provide a list of projects presently under Contract, the awarded Contract amount of each, the approximate adjusted Contract amount of each (if applicable), and the dollar amount or percent of completion of each.
- (k) Bidder shall be able to provide a list of Contracts which have resulted in lawsuits, whether against Bidder as a prime contractor, against Bidder as a subcontractor, or against Bidder as a party in any other capacity; or against subcontractors or suppliers performing work for Bidder or under Contract held by Bidder.
- (l) Bidder shall be able to provide a list of Contracts defaulted.
- (m) Bidder shall be able to provide a statement indicating whether or not Bidder has ever filed bankruptcy.
- (n) Bidder shall be able to provide a list of all officers of the firm, which list shall also indicate those officers who, while in the employ of the firm or in the employ of previous firms, were associated with Contracts which resulted in lawsuits, Contracts defaulted, or firms which filed for bankruptcy.
- (o) Bidder shall maintain personnel guaranteed to be employed in the responsible charge of the Work, which personnel possess sufficient technical experience to ensure the satisfactory completion of the Work. Bidder shall be able to provide the names and technical experience of such personnel, as well as statements as to whether the personnel have or have not performed

satisfactorily on other contracts of like nature and magnitude or comparable difficulty at similar rate of progress.

- (p) Bidder shall be able to provide a list of subcontractors and suppliers anticipated to be employed by Bidder for the purpose of completing the Work, including the firm name, street address and description of place of business; mailing address of business (if different); phone, fax and e-mail contact information of business; name of primary contact; and a list of any projects or contracts for which Bidder currently owes monies to said firm, which list shall include a description of the project or contract, the amount currently due to said firm, the period of time for which those monies have been owed, and the expected date of payment of those monies.
- (q) Bidder shall participate in active apprenticeship and training programs approved by and registered with the United States Department of Labor Bureau of Apprenticeship and Training for each of the trades of work contemplated under the Contract. Bidder shall be able to provide evidence of Bidder's participation in such apprenticeship and training programs.
- (r) Bidder shall only employ subcontractors who meet the requirements prescribed in this section and other sections of these specifications.
- (s) Bidder shall be able to provide such other information as may assist the Village in determining whether the Bidder is adequately prepared to fulfill the Contract.

These requirements and qualifications are not intended to discourage bidding, to make it difficult for qualified Bidders to submit Bids, or to discourage beginning contractors. The purpose of these requirements and qualifications is to allow the Village to obtain sufficient information about Bidder's financial state, available equipment, personnel, and previous work experience so that the Village may mitigate the hazards involved in awarding contracts to parties who may not be qualified to perform the Work as specified.

A copy of Village of Villa Park Ordinance No. 3733, amending the requirements of bidders for construction projects, is provided as Appendix 3.

INCREASED OR DECREASED QUANTITIES

The Village reserves the right to increase or decrease the amount of work shown in the plans in accordance with Section 109 of the Standard Specifications.

SUBCONTRACTORS

Add the following to the end of Section 108.01 of the Standard Specifications:

“The apparent low Bidder will submit to the Engineer within ten calendar days after the receipt of bids, a list of the names of Bidder’s proposed subcontractors along with a description of the work to be performed by each.”

COMPLETION OF PROJECT

All work shall be substantially completed and the roadway fully open to traffic as specified with these contract documents, less punch list items, within the following calendar days of Notice to Proceed:

- **90 calendar days**

The Contractor shall begin once Notice to Proceed is received from the Village. The Notice to Proceed will be determined by the Village. As soon as the Village gives permission for work to begin, the countdown of calendar days shall begin the following day. Under no condition shall the Contractor start work without prior approval from the Village.

Punch list items, including Final Inspection per Article 105.13 of the Standard Specifications, are to be completed within 10 calendar days of substantial completion. In the event the Contractor does not complete the work within the specified calendar days allotted by the contract, then Article 108.09 of the Standard Specifications shall apply except that “working days” will be replaced with “calendar days” in the specified article. Liquidated damages will accrue at a per calendar day rate defined by the table in Article 108.09 of the Standard Specifications.

WORKING HOURS

Working hours will be between 7:00 A.M. and 5:00 P.M., Monday through Friday, excluding holidays as designated by the Contract.

Contractor will not permit the performance of Work outside these working hours without Owner’s written consent, which may be given after prior written request to Engineer, except as otherwise required for the safety of persons or the Work or property at the Site or adjacent thereto, and except as otherwise stated in the Contract Documents.

If Contractor permits the performance of Work outside these working hours, Contractor will compensate Owner for the costs of inspection and other services provided by Engineer. Owner will determine the rates at which such inspection and other services are to be compensated. Owner will determine the interval or intervals at which billing will take place, and may, at Owner’s discretion, submit invoices for payment to Contractor, or deduct the costs from any monies due or to become due to the Contractor from Owner.

HOLIDAYS

Revise the list of legal holidays in Article 107.09 of the Standard Specifications to read:

New Year's Day
Easter
Memorial Day
Independence Day
Labor Day

Thanksgiving Day
Thanksgiving Friday
Christmas Eve
Christmas Day
New Year's Eve

SPECIAL EVENTS

The following special events are anticipated to take place in or near the project area during construction:

DATE	TIME	LOCATION	EVENT
Sundays, June 11-Oct 1	3 pm- 8:30 pm	Cortesi Park	Al's Car Show
Monday, June 12	11 am- 2:30 pm	Cortesi Park	Comic Book Writing
Tuesday, June 13, 20, 27	8 am- 12 noon	Cortesi Park	Little Medical School
Thursday, June 15	10 am- 2 pm	Cortesi Park	Mommy and Me, Princess tea
Saturday, June 17	10 am- 12 noon	Cortesi Park	Super Sensational Saturday
Tuesday, July 11, 18, 25	8 am- 12 noon	Cortesi Park	Little Medical School
Thursday, July 13	11 am- 2:30 pm	Cortesi Park	Fictional Writing Jr.
Saturday, July 15	10 am- 12 noon	Cortesi Park	Super Sensational Saturday
Thursday, August 3	5- 9 pm	Cortesi Park	Concerts in the Park
Monday, August 7	11 am- 2:30 pm	Cortesi Park	Journal Writing
Monday, August 7	7:30 pm	Cortesi Park	Movies in the Park
Thursday, August 10	5- 9 pm	Cortesi Park	Concerts in the Park
Saturday, August 12	10 am- 12 noon	Cortesi Park	Super Sensational Saturday
Monday, August 14	7:30 pm	Cortesi Park	Movies in the Park
Thursday, August 17	5- 9 pm	Cortesi Park	Concerts in the Park
Thursday, August 24	5- 9 pm	Cortesi Park	Concerts in the Park
Thursday, August 31	5- 9 pm	Cortesi Park	Concerts in the Park
Saturday, September 23	8 am- 9 pm	Cortesi Park	Ale Fest
Sunday, September 24	9 am- 6 pm	Cortesi Park	EISUS Fundraiser

The events listed are provided for informational purposes only. The events listed are tentative and all details are subject to change. Additional events may be added. The Village will provide the Contractor with changes to this list as appropriate.

Contractor shall make accommodations for all special events as directed by the Village or by the Engineer. Such accommodations may include, but not be limited to, cleaning up the project area or a portion of the project area, implementing additional traffic control or safety measures, removing materials or equipment from a portion of the project area, ceasing construction operations in a portion of the project area, scheduling construction operations around special events, and other accommodations as directed.

Compliance with this special provision will not be paid for separately but shall be included in the cost of the contract.

PUBLIC CONVENIENCE AND SAFETY (D-1)

Effective: May 1, 2012
Revised: July 15, 2012

Add the following to the end of the fourth paragraph of Article 107.09:

“If the holiday is on a Saturday or Sunday, and is legally observed on a Friday or Monday, the length of Holiday Period for Monday or Friday shall apply.”

Add the following sentence after the Holiday Period table in the fourth paragraph of Article 107.09:

“The Length of Holiday Period for Thanksgiving shall be from 5:00 AM the Wednesday prior to 11:59 PM the Sunday After”

Delete the fifth paragraph of Article 107.09 of the Standard Specifications:

“On weekends, excluding holidays, on roadways with Average Daily Traffic of 25,000 or greater, all lanes shall be open to traffic from 3:00 P.M. Friday to midnight Sunday except where structure construction or major rehabilitation makes it impractical.”

INSURANCE

Insurance and indemnification shall be according to applicable sections of the Standard Specifications, and shall also be according to the “IRMA Contractual Insurance Guidelines”, incorporated herein as Appendix 3. If a conflict is determined to exist between the requirements prescribed in the Standard Specifications and the

requirements prescribed in the IRMA Contractual Insurance Guidelines, such conflict will be resolved as follows:

- a. If a particular type of insurance coverage is required by one standard but not by both, that type of insurance coverage will be required.
- b. If the minimum limits of insurance coverage required by one standard differ from those required by the other standard, the higher minimum limits of insurance coverage will prevail.
- c. If any other conflicts are determined to exist between the requirements prescribed in the two standards, the stricter of the two requirements will prevail. Owner will make the final determination as to what constitutes a stricter requirement.

DUPAGE COUNTY HIGHWAY PERMIT

A DuPage County Highway Permit is required for this project. Contractor shall maintain insurance coverages of the types and in the minimum coverage amounts required by the DuPage County Highway Permit. Contractor shall provide a certificate of insurance listing DuPage County as the certificate holder and as an additional insured. Contractor shall provide other insurance documentation as required by DuPage County or by the permit. Contractor shall provide all other necessary documentation or paperwork as required by the permit, and shall sign all documents pertaining to the permit as required. Contractor shall comply with all conditions of the permit. This work will not be paid for separately but shall be included in the cost of the contract.

MAINTENANCE GUARANTEE

The Contractor shall execute and deliver to the Village, before final payment will be issued, a written warranty, in a form satisfactory to the Village, which guarantees that the work is in accordance with the Contract Documents and will not be defective. This warranty shall guarantee this work for a period of one year from the date of acceptance of the work and final payment by the Village.

The Contractor shall furnish a warranty bond in an amount equal to ten percent (10%) of the contract amount, or \$100,000, whichever is greater, by a surety satisfactory to the Village to guarantee Contractor's warranty to repair defective work.

If within the guarantee period, any work is found to be defective, as determined by the Village, the Contractor shall promptly and without cost to the Village, correct or repair such defective work, or remove and replace the defective work in accordance with the Special Provisions for the items in question.

MOBILIZATION

Mobilization shall be according to Section 671 of the Standard Specifications except as modified herein.

Revise Article 671.02, Basis of Payment, to read:

“671.02 Basis of Payment. Mobilization will not be paid for separately but shall be included in the unit bid prices of the items for which this work applies.”

CONSTRUCTION SAFETY AND HEALTH STANDARDS

It is a condition of this contract and shall be made a condition of each subcontract entered into pursuant to this contract that the Contractor and any Subcontractor shall not require any laborer or mechanic employed in performance of that contract to work in surroundings or under working conditions which are unsanitary, hazardous or dangerous to their health or safety, as determined under Federal Construction Safety and Health Standards.

MAINTENANCE OF ROADWAYS

Effective: September 30, 1985

Revised: November 1, 1996

Beginning on the date that work begins on this project, the Contractor shall assume responsibility for normal maintenance of all existing roadways within the limits of the improvement. This normal maintenance shall include all repair work deemed necessary by the Engineer, but shall not include snow removal operations. Traffic control and protection for maintenance of roadways will be provided by the Contractor as required by the Engineer.

If items of work have not been provided in the contract, or otherwise specified for payment, such items, including the accompanying traffic control and protection required by the Engineer, will be paid for in accordance with Article 109.04 of the “Standard Specifications”.

KEEPING ROADS OPEN TO TRAFFIC

All roads shall remain open to traffic unless otherwise shown on the contract plans. When necessary to close one lane because of construction, the Contractor shall maintain one-way traffic during construction hours with the use of signs and flaggers as shown on the Traffic Control Standards. Two lanes of traffic will be maintained during nights and weekends when no construction activities are being carried on.

RESPONSIBILITY FOR VANDALISM

The contractor shall be responsible for the defacement of any concrete pours before they have set up. Concrete pavement, sidewalk, driveway, or curbing that has been defaced, in the opinion of the Engineer, shall be removed and replaced by the contractor at Contractor's own expense.

SHOP DRAWINGS AND SUBMITTALS

Prior to fabrication of materials, the Contractor shall submit shop drawings of the materials to the Engineer for review. Shop drawings shall consist of complete descriptive literature on the materials including all pertinent dimensions, material specifications, and data. Prior to submitting shop drawings to the Engineer, the Contractor shall first review the shop drawings and make corrections or revisions which are appropriate. A minimum of three (3) copies of shop drawings must be submitted. Two (2) of the copies submitted shall be retained for use by the Engineer and Owner, and the remaining copies shall be returned to the Contractor. The Contractor shall be required to maintain a complete set of shop drawings on the job site at all times while work is in progress and shall make them available to the Engineer upon request.

Submit the following shop drawings, certifications and samples required in the specifications:

- PVC, RCP and DI pipes.
- Manholes, Chimney Seals, External wrap, Castings, Grates, Flexible Synthetic Rubber Boot, Extrudable Preform or Plastic Gasket, EZ Stik, Non-shrink Grout.
- Restrained joints, mission couplings.
- Pre-construction television inspection.
- B-box, Curb Stop, Corporation Stop.
- Traffic Control Plans.
- Internal video inspection of new sewers (post construction).
- Operations and maintenance manuals (post construction).

This is a non-exhaustive list. The Contractor shall provide all shop drawings that are required in the specifications.

CLEAN UP

The cost of cleanup operations shall be spread evenly through the bid items on the proposal. Clean up shall consist of removing all debris from the job site, and removal of all excess dirt, pipe pieces, lumber scraps, paper cups, etc., left by the Contractor's forces. Clean up shall be performed as the work progresses, and a final clean up shall be done after all operations, including jetting and resurfacing, are completed.

BRACING AND SHEETING

Description. The Contractor, if necessary, shall furnish, place and maintain all bracing and sheeting to safeguard adjacent utilities, as well as the work done under this contract.

Basis of Payment. The cost of such required bracing and sheeting will not be paid for separately but shall be considered as included in the unit bid prices of the contract, and additional compensation will not be allowed.

PIPE BEDDING

Description. The Contractor shall furnish, place, compact and transport course aggregate as detailed hereinafter for pipe bedding to a minimum depth of 4" below the bell of the pipe and 12" above the bell of the pipe.

Construction Methods. The bedding for pipe installation shall be as shown on the Drawings. The aggregate gradations for bedding depending on the pipe material shall be as follows:

1. PVC Pipe: CA 7 or 11, ¾-1" washed gravel,
2. Concrete Pipe: CA 7, 1" washed gravel,
3. Ductile Iron Pipe: CA 7, 1" washed gravel,
4. Cables, Copper Water Services: CA 7, 1" washed gravel,
5. Trench bottom stabilization: CA 7, 1" washed gravel.

Basis of Payment. The cost of pipe bedding will not be paid for separately but shall be considered as included in the unit bid prices of the contract, and additional compensation will not be allowed.

SEWER FLOW CONTROL

This work shall include control of sanitary sewer flow during closed circuit television (CCTV) inspection, sewer cleaning operations, manhole rehabilitation, manhole installation and all other sewer maintenance, inspection or construction activities. The

**CENTRAL BOULEVARD IMPROVEMENTS
VILLAGE OF VILLA PARK**

Contractor shall be fully responsible for maintaining sewer service during these operations and shall not be allowed to backup or flood any sewer system user, building or property. The Contractor shall be solely liable for property damages that result from the work being performed.

During sewer cleaning operations, only 25% of the internal pipe diameter flow or "limited sewage flow" is acceptable. Flows shall be reduced by plugging, blocking, manually operating pump stations or bypass pumping. During sewer televising operations, only 5% of the internal pipe diameter flow is acceptable. During manhole installation, manhole rehabilitation and point repairs, no flows will be allowed.

Since complete stoppage or bypassing of flow may be required during installation of new sewers, point repairs and manhole rehabilitation work, the Contractor may be required to submit drawings and complete design data showing methods and equipment to be utilized in bypass and dewatering operations. The bypass plan shall include the following information:

1. Location of temporary sewer plugs and bypass discharge lines indicated on plans
2. Capacities of pumps, prime movers, and standby equipment
3. Type of standby power source
4. Traffic control plan

When pumping and bypassing is required, the Contractor shall furnish all temporary pumps, conduits, and other equipment to divert the flow of sewage around the sewer section in which work is to be performed. The bypass system shall have sufficient capacity to handle existing flow plus additional flow that may occur during peak flow periods or from precipitation. The Contractor shall construct bypass system of material to prevent leakage during pumping operation.

The Contractor shall equip all engines with mufflers and/or enclose to keep noise level less than 50 decibels, or 10 decibels above ambient noise levels when measured at building closest to noise source.

The Contractor shall maintain sufficient labor, equipment and materials on site to ensure continuous and successful operation of bypass and dewatering systems including the following:

1. Keep standby pumps fueled and operational at all times
2. Maintain on site sufficient number of valves, tees, elbows, connections, tools, sewer plugs, piping, and other parts or system hardware to ensure immediate repair or modification of any part of system as necessary.
3. Provide piping, joints and accessories designed to withstand at least twice the maximum system pressure or 50 psi (345 kPa), whichever is greater.

In areas where flows are bypassed, all discharge flow shall be returned to the sanitary sewer. No bypassing to ground surface, receiving waters, storm drains, or bypassing which results in groundwater contamination or potential health hazards shall be permitted.

In the event sewage is released into a storm drainage system or street, the Contractor shall immediately stop the release, notify IEPA, and take all necessary actions to clean up and disinfect spillage to satisfaction of the Engineer.

During plugging or bypass pumping operations the Contractor shall utilize sewer plugs specifically designed so that all or any portion of sewage can be released. During sewer flow control operations, reduce flow to comply with requirements as describe above. After cleaning, inspection, installation or rehabilitation work has been completed, restore the flow to normal. All plugging, bypass pumping and sewer flow control operations shall be considered incidental to the Contract and shall not be compensated for separately.

Basis of Payment. The cost of sewer flow control will not be paid for separately but shall be considered as included in the unit bid prices of the contract, and additional compensation will not be allowed.

ADJUSTING RINGS

All drainage and utility structures which are constructed, reconstructed, or adjusted as a part of this contract shall have adjusting rings installed between the topmost section of the structure and the casting.

Each structure shall be fitted with a minimum of one adjusting ring and a maximum of two adjusting rings. The topmost adjusting ring on each structure shall be rubber. The second adjusting ring on each structure, if needed, shall be precast concrete with steel reinforcement. The total height of all adjusting rings on a single structure shall be a minimum of 2 inches and a maximum of 12 inches.

The mating faces of adjusting rings shall be smooth, parallel, and free of cracks, chips, spalling, or casting irregularities. Rubber mastic shall be installed between each joint.

Adjusting rings will not be paid for separately but shall be included in the cost of the items to which this work pertains.

FRAMES, GRATES AND LIDS

Frames, grates, lids and all other castings furnished under this contract shall be in accordance with Section 602 and Section 604 of the Standard Specifications, except as modified herein.

Castings shall conform to ASTM A48 Class 30. Castings shall be free of cracks, holes, swells, cold shuts, and patches. Castings shall not be coated or painted.

Frames, grates, lids and other castings shall be furnished in accordance with the following:

1. Sanitary manholes, storm manholes, and water valve vaults shall be furnished with Type 1 frames and closed lids. Type 1 frames and closed lids shall be Neenah R-1713 self-sealing or approved equal.
2. Catch basins and inlets located in non-depressed curb and gutter shall be furnished with Type 11 frames and grates. Type 11 frames and grates shall be Neenah R-3281-A or approved equal.
3. Catch basins and inlets located in depressed curb and gutter shall be furnished with modified Type 11 frames and grates. Modified Type 11 frames and grates shall be Neenah R-3281-A with depressed curb grate or approved equal
4. Storm inlets located in parkway shall be furnished with Type 1 frames and open lids. Type 1 frames shall be Neenah R-1713 self-sealing and open lids shall be Neenah R-2504 Standard grate Type D or approved equal.

All other castings not specified above shall be as shown on the plans or as directed by the Engineer. If any of the castings specified are not compatible in the field due to frame height or other constraints, the Contractor shall propose an alternate casting to the Engineer for approval and shall furnish the alternate casting if approved.

Frames, grates, lids and other castings located within curb ramps or crosswalks shall be substituted with ADA compliant castings.

All closed lid castings furnished under this contract shall be self-sealing, gasketed, watertight, and shall have machined bearing surfaces and concealed pick holes. The top surface of all closed lids shall be embossed with the words "VILLAGE OF VILLA PARK". The top surface of closed lids shall also be embossed with the word "SANITARY", "STORM", or "WATER" as appropriate.

This work will not be paid for separately but shall be included in the cost of all pay items that include the furnishing of frames, grates, lids, or other castings.

DATE OF MANUFACTURE

All manufactured materials furnished under this contract, including, but not limited to, pipe, drainage and utility structures, castings, fire hydrants, valves, stops, and fittings, shall have been manufactured no earlier than January 1 of the calendar year in which they are to be installed.

SALVAGE AND DISPOSAL OF EXISTING CASTINGS

Existing castings which are removed and are not to be reused will be inspected by the Engineer. Castings which are determined by the Engineer to be in satisfactory condition shall remain the property of the Village and shall be delivered by the Contractor to the Village of Villa Park Public Works Department yard located at 35 South Ardmore Avenue in Villa Park. Castings which are determined by the Engineer to be in unsatisfactory condition shall become the property of the Contractor and shall be removed from the site immediately and properly disposed of by the Contractor. The delivery or disposal of castings will not be paid for separately but shall be included in the cost of all items that include removal of an existing structure or casting.

CONCRETE WASHOUT FACILITY

Description. The Contractor shall take sufficient precautions to prevent pollution of streams, lakes, reservoirs, and wetlands with fuels, oils, bitumens, calcium chloride, or other harmful materials according to Article 107.23 of the Standard Specifications.

General. To prevent pollution by residual concrete and/or the by-product of washing out the concrete trucks, concrete washout facilities shall be constructed and maintained on any project which includes cast-in-place concrete items. The concrete washout shall be constructed, maintained, and removed according to this special provision.

The concrete washout facility shall be constructed on the job site in accordance with Illinois Urban Manual practice standard for Temporary Concrete Washout Facility (Code 954). The Contractor may elect to use a pre-fabricated portable concrete washout structure. The Contractor shall submit a plan for the concrete washout facility, to the Engineer for approval, a minimum of 10 calendar days before the first concrete pour. The working concrete washout facility shall be in place before any delivery of concrete to the site. The Contractor shall ensure that all concrete washout activities are limited to the designated area.

The concrete washout facility shall be located no closer than 50 feet from any environmentally sensitive areas, such as water bodies, wetlands, and/or other areas indicated on the Plans. Adequate signage shall be placed at the washout facility and elsewhere as necessary to clearly indicate the location of the concrete washout facility to the operators of concrete trucks.

The concrete washout facility shall be adequately sized to fully contain the concrete washout needs of the project. The contents of the concrete washout facility shall not exceed 75% of the facility capacity. Once the 75% capacity is reached, concrete placement shall be discontinued until the facility is cleaned out. Hardened concrete shall be removed and properly disposed. Slurry shall be allowed to evaporate, or shall be removed and properly disposed. The Contractor shall immediately replace damaged basin liners or other washout facility components to prevent leakage of concrete waste

from the washout facility. Concrete washout facilities shall be inspected by the Contractor after each use. Any and all spills shall be reported to the Engineer and cleaned up immediately. The Contractor shall remove the concrete washout facility when it is no longer needed.

Basis of Payment. This work will not be paid for separately but shall be considered as included in the unit bid prices of the contract, and additional compensation will not be allowed.

USE OF FIRE HYDRANTS

Revise Article 107.18, Use of Fire Hydrants, of the Standard Specifications to read:

“107.18 Use of Fire Hydrants. If Contractor requires water for the completion of construction operations, and desires to obtain water from the Village, the Contractor shall make written application to the Village. If such application is approved by the Village, the Contractor shall obtain water from the fire hydrant located at 100 West Home Avenue, adjacent to the Village of Villa Park Fleet Maintenance Garage. Contractor’s use of said hydrant and methods of obtaining water shall be in compliance with all applicable ordinances, rules, and regulations concerning such use. Contractor shall furnish all labor and equipment necessary to make a connection to said hydrant, and to obtain and transport water.

Prior to obtaining water, Contractor shall make written application to the Village for temporary use of a hydrant meter. If the application for temporary use of a hydrant meter is approved, the Contractor shall provide a deposit of three thousand dollars (\$3,000.00) to the Village for the temporary use of said hydrant meter, which deposit will be held by the Village until such time that the meter is returned to the Village by the Contractor in satisfactory condition. Contractor shall use said hydrant meter when obtaining water, and shall comply with all conditions for the use of said meter. Contractor shall return the hydrant meter to the Village within 24 hours of project completion and within 24 hours of any request by the Village that the hydrant meter be returned.

If Contractor makes application for temporary use of a hydrant meter and the application is not approved, Contractor shall make record of the quantity of water obtained, along with the date and time obtained, and shall report such information after each use to the Village of Villa Park Public Works Department, 11 West Home Avenue. If such use takes place outside of the normal working hours of the Public Works Department, Contractor shall report such information immediately upon the commencement of normal working hours.

Contractor shall not use, operate or obtain water from any hydrants other than the hydrant prescribed. Contractor shall not obtain water from the Village for construction operations or activities not under contract with the Village.

If a water main break occurs and the Village determines that the water main break is a result of Contractor's use of a hydrant, the Village may require the Contractor to repair the water main break in accordance with all applicable construction standards and requirements and at no cost to the contract, or may repair the water main break by other means and invoice the Contractor for reimbursement of the Village's costs.

Water usage will be measured according to the Special Provisions WATER USAGE DEDUCTION and WATER USAGE CREDIT."

PROTECTION OF EXISTING DRAINAGE FACILITIES DURING CONSTRUCTION

Unless otherwise noted in the contract plans, the existing drainage facilities shall remain in use during the period of construction.

Locations of existing drainage structures and sewers, if shown on the contract plans, are approximate. Prior to commencement of work, the Contractor, at his/her own expense, shall determine the exact location of existing structures which are within the proposed construction site.

All drainage structures are to be kept free from any debris resulting from construction operations. All work and materials necessary to prevent accumulation of debris in the drainage structure resulting from construction operations shall be removed at the Contractor's own expense, and no extra compensation will be allowed.

Unless reconstruction or adjustment of an existing manhole, catch basin, or inlet is called for in the contract plans or ordered by the Engineer, the proposed work shall meet the existing elevations of these structures. Should reconstruction or adjustment of a drainage structure be required by the Engineer in the field, the necessary work and payment shall be done in accordance with Section 602 and Article 104.02 respectively, of the Standard Specifications.

Existing frames and grates are to remain unless otherwise noted in the contract plans or as directed by the Engineer. Frames and grates that are missing or damaged prior to construction shall be replaced. The type of replacements frame or grate shall be determined by the Engineer, and replacement and payment for same shall be in accordance with Section 604 and Article 104.02 respectively, of the Standard Specifications unless otherwise noted in the plans or special provisions.

SPECIAL PROVISIONS FOR CONTRACT ITEMS

This shall be a unit price contract and shall include all work mentioned in the Project's Plans and Specifications and any other work, not specifically mentioned, that is necessary for constructing the improvement in a skilled and professional manner. Any conflicts or omissions in the Plans or Specifications shall be brought to the attention of the Engineer. The Engineer's decision in resolving such matters shall be final. The Contractor shall in no manner take advantage of conflicts or omissions should they occur and it shall be the Contractor's responsibility to bring such components of the Contract to the attention of the Engineer so that they can be properly resolved.

The quantities bid upon in the Proposal are estimated quantities, except where an item is noted to be supplied "complete." The Contractor shall be paid for actual quantities, in place, as measured and agreed upon by the Engineer and Contractor. The Contractor shall be paid in full for items to be supplied "complete" when said item is finished, or at a percentage of the bid amount agreed upon by the Owner, Engineer and Contractor if the item is not complete.

ITEM #1: EARTH EXCAVATION

Description. The work shall be performed in accordance with Section 202 of the Standard Specifications.

This item includes all of the excavating and grading work necessary on this Project to establish the subgrade elevations of the proposed pavement to be constructed on Central Boulevard, Myrtle Avenue and Cortesi Avenue, as indicated on the plans.

Any excavation of the parkway which is required to give a uniform slope from the edge of sidewalk to the top of the curb shall also be paid for under this item. The payment for EARTH EXCAVATION will only be applicable where the proposed top of curb has been lowered substantially from the existing grade (four-inches or greater), and a uniform parkway slope is unattainable through the basic grading operations of topsoil placement. The proposed sodding and topsoil section will be subtracted from the measured volume to be excavated. Any excavation and grading of the parkway where the top of curb has not been lowered by four inches or greater shall be included in the item for TOPSOIL FURNISH AND PLACE, 4".

Also included in the work under this item are the removal and disposal of all brush, rock, construction debris, hedges, trees of sizes less than 6" in diameter, and other excess materials located within the construction area of the Project's improvements.

If agreement is not reached, and for portions of work performed that differ from the Plans, quantities will be computed by the following methods. Excavation for the pavement will be computed by the method of average end areas. Original ground elevations used in the calculations shall be those shown on the Plans, or as corrected or interpolated by the

Engineer as necessary. The subgrade elevations used in the calculations will be as determined from Plan grades, including any revisions to Plan grades as made or approved by the Engineer. End areas will be at fifty (50) foot intervals. The width calculation of each end area will equal the pavement width.

For the sections of pavement to be reconstructed, this item includes all the excavating and grading work necessary to establish the subgrade elevations of the proposed pavement other than that excavation required as part of the items for COMBINATION CURB AND GUTTER REMOVAL and PAVEMENT REMOVAL.

The existing pavement is comprised of Hot-Mix Asphalt over a variable depth concrete base. The removal of this pavement will NOT be paid for under this item, but shall be paid for as PAVEMENT REMOVAL. Cores have been taken along the route of improvements and the results have been included in the project plans. These cores, which showed an average section depth of 2" asphalt over 7" of concrete, will be used for informational purposes only.

PAVEMENT REMOVAL will account for 9" of concrete/asphalt removal regardless of actual thickness encountered on all streets. All remaining depth of excavation will be paid for under this item. No additional compensation will be granted to the Contractor for variances in existing pavement depth along the limits of removal.

Basis of Payment. This work will be paid for at the Contract unit price per Cubic Yard for EARTH EXCAVATION.

ITEM #2: PAVEMENT REMOVAL

Description. The work shall be performed in accordance with Section 440 of the Standard Specifications.

This item shall consist of the removal of existing HMA and concrete pavement. Pavement cores have been taken along the route of improvements and the results have been included in the project plans. These cores, which showed an average section depth of 2" asphalt over 7" of concrete, will be used for informational purposes only.

Payment for this item will assume an average thickness of 2" Hot-Mix Asphalt over 7" of existing concrete base. This will be the payment depth for this item regardless of actual depth encountered.

When removing the street pavements, any further excavation beyond 9" (regardless of the actual depth found) to reach the proposed subgrade shall be paid for under the item EARTH EXCAVATION.

All pavement removal areas shall be saw-cut full depth along their perimeter prior to the removal of the pavement. The use of drop hammers will not be allowed for breaking these pavements.

Basis of Payment. This work will be paid for at the Contract unit price per Square Yard for PAVEMENT REMOVAL.

ITEM #3: REMOVAL AND DISPOSAL OF UNSUITABLE MATERIAL

Description. The work shall be performed in accordance with Section 202 of the Standard Specifications.

This item shall include removing any areas of poor subgrade materials (undercut areas). No undercuts are to be made without the approval of the Engineer.

The Contractor shall provide a loaded truck to “proof-roll” the exposed subgrade. This shall be performed once a minimum of a 300-foot section of proposed subgrade has been exposed and prepared for proof-rolling operations. The Contractor shall also notify the Engineer a minimum of 4 hours in advance of any “proof-roll”.

When unsuitable soil is removed the trench bottom shall be stabilized and paid for with POUROUS GRANULAR EMBANKMENT.

Basis of Payment. This work will be paid for at the Contract unit price per Cubic Yard for REMOVAL AND DISPOSAL OF UNSUITABLE MATERIAL.

ITEM #4: POROUS GRANULAR EMBANKMENT

Description. The work shall be performed in accordance with Section 207 of the Standard Specifications.

This item shall consist of installing crushed aggregate with a maximum aggregate size of three inches (3”), Gradation CA-1, in areas where unsuitable soil has been removed.

Where undercut depths are made at less than nine-inches (9”), the Engineer may allow the use of CA-6 Aggregate. Recycled concrete shall be permitted for this item, except for the replacement of unsuitable soil in a pipe trench.

Basis of Payment. This work will be paid for at the Contract unit price per Cubic Yard for POUROUS GRANULAR EMBANKMENT.

ITEM #5: COMBINATION CURB AND GUTTER REMOVAL

Description. The work shall be performed in accordance with Section 606 of the Standard Specifications.

This item includes the removal of the existing combination curb and gutter at locations shown on the Plans and as designated by the Engineer. Included in this item is the removal of all types of combination curb and gutter encountered on the Project. Also included in this item is the removal and disposal of any asphalt that has been overlaid into the gutter of any curb that is designated for removal. This item shall also include any additional excavation behind the curb necessary to install the proposed curb and gutter and beneath the curb and gutter necessary to reach the proposed subgrade.

All curb and pavement removal areas shall be saw-cut full depth along their perimeter prior to the removal of the pavement.

On Myrtle Avenue and Cortesi Avenue, the saw-cutting and removal of the wedge of concrete pavement or asphalt and aggregate in front of the curb and gutter (to facilitate framing) shall be included in the cost of this item.

All removal shall terminate at existing expansion joints or at new full-depth saw-cut lines as determined by the Engineer. The existing pavements abutting the curb and gutter shall be protected while removal work is being done to avoid unnecessary pavement restoration.

Basis of Payment. This work will be paid for at the Contract unit price per Foot for COMBINATION CURB AND GUTTER REMOVAL.

ITEM #6: SIDEWALK REMOVAL

Description. The work shall be performed in accordance with Section 440 of the Standard Specifications.

This item includes the removal of sidewalk at locations shown on the Plans and as designated by the Engineer. The removal of concrete, brick, flagstone, and asphalt sidewalks is also included in this item. These sidewalks shall be excavated to the subgrade as necessary such that the proposed five inch (5") thick sidewalk, including four inches (4") of crushed stone, gradation CA-6, can be constructed.

Any additional excavation needed to bring the section to the bottom of proposed cross-section of sidewalk will be included in this item.

Basis of Payment. This work will be paid for at the Contract unit price per Square Foot for SIDEWALK REMOVAL.

ITEM #7: DRIVEWAY PAVEMENT REMOVAL

Description. The work shall be performed in accordance with Section 440 of the Standard Specifications.

This item includes the removal of existing asphalt and concrete driveway pavements at locations shown on the Plans and as designated by the Engineer

The use of drop hammers will not be allowed for breaking these pavements. These driveways shall be excavated to the subgrade of the proposed driveway, including the necessary thickness of compacted, CA-6 stone. This work shall be included in the cost of this item.

The limits of removal shall typically be from the back of curb to the face of sidewalk, but shall be designated in the field by Engineer.

The Contractor shall saw-cut the driveway pavement full-depth at the limits of removal, which costs shall be included in this item. All driveway aprons scheduled for replacement shall be removed with extreme care in order to avoid damage to existing garages, garage foundations, or adjacent sidewalks scheduled to remain. Any damage caused by the removal of the driveway pavement shall be repaired or otherwise resolved by the Contractor to the satisfaction of the Village and the property owner. No additional compensation will be allowed. Any additional excavation required to reach the proposed subgrade shall be considered included in the cost of this item.

Additionally, if any additional stone bedding is needed to offset an unforeseen thickness of driveway removal, the additional stone would be paid for under this item as well.

Basis of Payment. This work will be paid for at the Contract unit price per Square Yard for DRIVEWAY PAVEMENT REMOVAL.

ITEM #8: HOT-MIX ASPHALT SURFACE REMOVAL – (VARIABLE DEPTH)

Description. The work shall be performed in accordance with Section 440 of the Standard Specifications.

This item will consist of the removal of the existing hot-mix asphalt surface over PCC base course on streets to be resurfaced to provide the profile of the proposed pavement cross section.

The depth of the material removed will vary from zero to four inches (0" - 4"), depending on the thickness of the hot-mix asphalt surface overlay and proposed grading of curbs. The above work shall be done after the placement of the proposed curb and gutter.

The hot-mix asphalt shall be milled to allow for three (3") of new hot-mix asphalt to be laid against the proposed gutter edge. Any milling of the existing concrete base course necessary to meet these specifications shall be considered included in the cost of this item.

If any reinforcing steel protrudes from the roadway after the grinding operation has been completed, the Contractor will be required to cut the steel and properly dispose of it until the Village is satisfied with the safety of the jobsite.

Sufficient milling or grinding passes shall be made over the existing pavement so that all irregularities and high spots are eliminated from the pavement's surface before it is overlaid with new material.

Hot-mix asphalt surface removal shall be measured in place and the area computed in square yards for the total increment of material removed. The area measured shall be paid for only once regardless of the number of passes needed to remove the material.

Basis of Payment. This work will be paid for at the Contract unit price per Square Yard for HOT-MIX ASPHALT SURFACE REMOVAL - (VARIABLE DEPTH).

ITEM #9: HOT-MIX ASPHALT SURFACE REMOVAL – BUTT JOINT

Description. The work shall be performed in accordance with Section 406 and 440 of the Standard Specifications

This item shall consist of the removal of any hot-mix asphalt surface at the butt joints.

The depth of the material removed will vary from zero to four inches (0" - 4"), depending on the thickness of the hot-mix asphalt surface overlay. The above work shall be done after the placement of the proposed curb and gutter.

Any milling of the existing concrete base course necessary to meet these specifications shall be considered included in the cost of this item.

It is anticipated that the removal shall provide for a depth of two-inches (2") of asphalt surface to be installed. Work is to be done within 48 hours of surface placement.

The Contractor shall be required to saw cut the hot-mix asphalt at the limits of removal.

Basis of Payment. This work will be paid for at the Contract unit price per Square Yard for HOT-MIX ASPHALT SURFACE REMOVAL – BUTT JOINT.

ITEM #10: REMOVAL AND DISPOSAL OF REGULATED SUBSTANCES

Description. This work shall be according to Article 669 of the Standard Specifications and the following:

This item includes the **additional** cost incurred for transporting and disposing of excavated material from the right-of-way that after environmental testing would be classified as Non-Special Waste.

Basis of Payment. This work will be paid for at the Contract unit price per Cubic Yard for REMOVAL AND DISPOSAL OF REGULATED SUBSTANCES.

ITEM #11: FRAMES AND GRATES TO BE ADJUSTED

Description. This work shall be according to Article 603 of the Standard Specifications and the following:

This item shall consist of the adjustment of existing manhole, catch basin, inlet, and valve vault frames at locations shown on the plans or as directed by the Engineer. All proposed and existing structures within the pavement area are to be adjusted to finish grade after the binder has been placed.

The pavement disturbed by the adjustment will be replaced with concrete base course to the grade of the hot-mix asphalt binder course or level binder. The removal and replacement of this pavement shall be included as part of this item.

Structures, which are located in the curb and gutter, shall not be adjusted to final grade until the curb and gutter has been placed to within five feet (5') of each side of the structure. At this time the Contractor may adjust the structure to the proper elevation to achieve drainage of the curb and gutter.

The adjustment of frames and grates on newly installed structures shall not be paid for separately but shall be considered as part of the respective item for the installation of the proposed structures.

The Contractor will be responsible for coordinating with public utility companies to have any of their structures adjusted. The Contractor will not be paid for adjusting electrical hand-holes, communication vaults, or Nicor facilities; however, he must ensure the work is completed in partnership with his own schedule. This oversight and coordination is included in the cost of this item.

Basis of Payment. This work will be paid for at the Contract unit price per Each for FRAMES AND GRATES TO BE ADJUSTED.

ITEM #12: STRUCTURE TO BE RECONSTRUCTED

Description. This work shall be according to Article 603 of the Standard Specifications and the following:

This item shall consist of the reconstruction of existing manholes, catch basins, and valve vaults at locations shown on the plans or as directed by the Engineer. The reconstruction work shall not disturb the existing bench but shall be concentrated upon the reconstruction of all defective barrel, cone, and adjustment sections. The Engineer shall mark the depth to which the structure shall be reconstructed prior to the beginning of the work on the structure. This depth will need to be verified with the Engineer prior to ordering a cone or precast barrel sections.

For structures located within asphalt pavement, the pavement disturbed by the reconstruction shall be replaced with concrete base course to the grade of the hot-mix asphalt binder course or level binder. This pavement replacement shall be included in the cost of this item.

Only precast concrete barrel, cone, flat top, and adjustment ring sections shall be used to replace defective sections of the structure. It shall be the Contractor's responsibility to determine the size of the existing structure. No additional payment will be made for the various sizes of structures encountered. Any manholes, catch basins, or valve vaults which are reconstructed shall have all debris removed from the bench regardless of whether it resulted from the construction project.

External chimney seals are to be installed on all structures that require reconstruction. Acceptable external chimney seals include Cretex Classic or an approved equivalent.

The lowest precast section shall have a flat surface on the bottom edge that rests on the remaining portion of the existing structure. Reconstructions with pipe connections under this item will require the use of watertight flexible rubber connectors conforming to ASTM C-443 & C-923 with stainless steel bands for any pipe openings within the precast sections that are being replaced.

Any pipe up to four feet (4') in length per each pipe used needed to connect existing pipe (or proposed laterals) to the structure to be reconstructed shall be included in the cost of this item. The pipe shall have a minimum standard dimension ratio (SDR) of 26 and shall conform to ASTM designation D-2241 (water quality pipe). Connections to existing sewer lines shall be made using non-shear Fernco RC Series or Mission Flex-Seal adjustable repair couplings equipped with stainless steel bands and shall be included in the cost of this item.

All excavation, bedding and trench backfill material necessary to backfill the structure and the length of pipe shall also be included in the cost of the structure.

Basis of Payment. This work will be paid for at the Contract unit price per Each for STRUCTURE TO BE RECONSTRUCTED.

ITEM #13: FRAMES AND LIDS

Description. This work shall be according to Article 604 of the Standard Specifications and the following:

This item includes the replacement of frames and lids on existing structures to be adjusted or reconstructed at locations shown on the Plans or as directed by the Engineer.

Refer to General Special Provisions for specifications on type required.

Basis of Payment. This work will be paid for at the Contract unit price per Each for FRAME AND LIDS.

ITEM #14: REMOVING STRUCTURES

Description. This work shall be according to Article 605 of the Standard Specifications and the following:

This item shall consist of the removal of manholes, drainage structures, or valve vaults at locations shown on the plans or as directed by the Engineer. It shall also be the responsibility of the contractor to seal all pipes at both ends that connect to other structures with brick and mortar. The void left by the removal of the structure will be filled with trench backfill and compacted.

Structures being removed where a new structure is to be installed will not be paid for separately but shall be included in the cost of the new item.

Basis of Payment. This work will be paid for at the Contract unit price per Each for REMOVING STRUCTURES.

ITEM #15: CATCH BASINS, TYPE A, 4' DIAMETER, TYPE 11 FRAME AND GRATE

Description. This work shall be according to Article 602 of the Standard Specifications and the following:

A four-foot (4') diameter restricted depth catch basin shall be installed at the locations shown in the plans or as directed by the Engineer and in accordance with the details shown in the plans.

It will be the responsibility of the Contractor to ensure all pipe openings are formed in the correct locations so that additional cutting of the precast structure is not necessary. All elevations on proposed structures shall be field verified by Contractor prior to ordering of any structures. No additional compensation will be granted for the coring of any structures and/or restocking fees.

Frames and lids shall be furnished in accordance with the following (or equivalent) schedule:

- Type 11 Frame and Grate: NEENAH R-3281-A.

If constraints in the field such as frame height become an issue during installation, the Contractor will propose an alternate frame and grate or frame and lid to the Engineer for approval.

Any pipe including the mainline sewer, up to four feet (4') in length per each pipe, used to connect existing pipes to the proposed structure shall be included in the cost of the proposed structure. The pipe shall have a minimum standard dimension ratio (SDR) of 26 and shall conform to ASTM designation D-2241 (water quality pipe). Connections to existing sewer lines shall be made using non-shear Fernco RC Series or Mission Flex-Seal adjustable repair couplings equipped with stainless steel bands and shall be included in the cost of this item.

All excavation, bedding and trench backfill material necessary to backfill the structure and the length of pipe shall also be included in the cost of the structure.

Basis of Payment. This work will be paid for at the Contract unit price per Each for CATCH BASINS, TYPE A, 4' DIAMETER, TYPE 11 FRAME AND GRATE.

ITEM #16 & 17: INLETS, TYPE A

Description. This work shall be according to Article 602 of the Standard Specifications and the following:

An inlet shall be installed at the locations shown on the Plans and in accordance with the details shown on the Plans.

It will be the responsibility of the Contractor to ensure all pipe openings are formed in the correct locations so that additional cutting of the precast structure is not necessary. All elevations on proposed structures shall be field verified by Contractor prior to ordering of any structures. No additional compensation will be granted for the coring of any structures and/or restocking fees.

Frames and lids shall be furnished in accordance with the following (or equivalent) schedule:

- Type 1 Frame shall be Neenah R 1713 and grate shall be Neenah R-2504 Standard grate Type D or approved equal.
- Type 11 Frame and Grate: NEENAH R-3281-A.

If constraints in the field such as frame height become an issue during installation, the Contractor will propose an alternate frame and grate or frame and lid to the Engineer for approval.

Any pipe including the mainline sewer, up to four feet (4') in length per each pipe, used to connect existing pipes to the proposed structure shall be included in the cost of the proposed structure. The pipe shall have a minimum standard dimension ratio (SDR) of 26 and shall conform to ASTM designation D-2241 (water quality pipe). Connections to existing sewer lines shall be made using non-shear Fernco RC Series or Mission Flex-Seal adjustable repair couplings equipped with stainless steel bands and shall be included in the cost of this item.

All excavation, bedding and trench backfill material necessary to backfill the structure and the length of pipe shall also be included in the cost of the structure.

Basis of Payment. This work will be paid for at the Contract unit price per Each for INLETS, TYPE A, of the frame and grate specified.

ITEM #18 TO 20: STORM SEWERS, PVC, SDR 26, ASTM 2241

Description. This work shall be according to Article 550 of the Standard Specifications and the following:

In those locations indicated on the Plans, polyvinyl chloride (PVC) sewer pipe of the size indicated shall be installed. The pipe shall have a minimum standard dimension ratio (SDR) of 26 and shall conform to ASTM designation D-2241 (water quality pipe). The joints shall be rubber gasket and conform to ASTM designations D-3139 and F-477. Pipe installation shall be in accordance with Section 31 of the "Standard Specifications for Water and Sewer Main Construction". The pipe bedding and backfill to twelve inches (12") above the top of pipe will be included in the cost of this item.

The price for this item shall also include plugging any existing abandoned storm laterals with two feet (2') of concrete inside the pipe, at both ends.

All excavation of earth required to access the sewer will be included in the cost of this item.

The proposed PVC sewer pipe may need to be connected to the existing drainage structure. This will be included in the cost of this item.

Basis of Payment. This work will be paid for at the Contract unit price per Foot for STORM SEWERS, PVC, SDR 26, ASTM 2241, of the diameter specified.

ITEM #21: COMBINATION CONCRETE CURB AND GUTTER, TYPE B-6.12

Description. This work shall be according to Article 606 of the Standard Specifications and the following:

The construction of the combination concrete curb and gutter shall be in accordance with the details for this item shown in the Plans. The proposed curb and gutter shall have a gutter flag having a minimum thickness of ten inches (10"). The height of the curb shall vary in accordance with the grades established by the Engineer.

The curb and gutter shall be laid upon a cushion of compacted crushed stone, gradation CA-6 having a minimum thickness of four inches (4"). Joints shall be tooled at a maximum spacing of fifteen feet (15') maximum. Between four (4) and twenty-four (24) hours after the curb has been placed, the tooled contraction joints and at any other locations as may be designated by the Engineer shall be saw-cut three inches (3") in depth. These joints shall then be sealed according to the requirements of Article 420.14(a) of the Standard Specifications for Road and Bridge Construction.

If the Contractor fails to properly cut the joints in the specified time period and the curb cracks, the entire curb section will be replaced from the nearest adjacent tooled joint at the Contractor's cost.

Three-quarter inch ($\frac{3}{4}$ ") bituminous expansion joint fillers with two (2) smooth, round, capped, epoxy coated, steel dowel bars each $\frac{3}{4}$ " in diameter and 18" long shall be placed at intervals not to exceed sixty feet (60'), at all radius or bend points, on both sides of structures within five feet (5') of structures and located within the curb and gutter, and at other locations designated by the Engineer. At locations where the proposed curb and gutter meets existing curb and gutter, two (2) epoxy coated, steel dowel bars shall be drilled into the existing curb and gutter.

At locations where the curb is to be replaced on streets that are not being reconstructed (Myrtle and Cortesi), a six-inch (6") wide wedge of concrete base course will be placed after the curb and gutter has been poured and the framing has been removed. The placement of the eight-inch (8") thick concrete base will be included in the cost of this item.

It shall be the Contractor's responsibility to provide curb depressions at locations where public sidewalks require ramping for pedestrian crossing. The depressions shall be constructed as shown in the details in the Plans and in basic compliance with the Accessibility Guidelines as detailed in the Americans with Disabilities Act (ADA).

After removal of the “back of curb” form, the excavated area behind the curb designated for sodding shall be immediately backfilled with select non-organic earth backfill in preparation for the placement of the topsoil. All areas where concrete or asphalt pavement is to be constructed shall be backfilled with crushed stone, gradation CA-7 and properly compacted. This stone must be compacted prior to framing the proposed sidewalk or driveway. The placement of the required backfill material shall be considered included in the placement of the curb and gutter.

One inch (1”) thick wooden forms shall be used to form all radius sections of curb and gutter. Masonite and steel forms will not be allowed.

This item will also be used when proposed public sidewalk exists directly behind the proposed back of curb and runs parallel to the roadway. In this instance, the framing of this item will be done according to the detail in the plan set, to allow for a “shelf” for the proposed adjacent sidewalk/driveway to rest on. The additional wood needed to frame this item will be included in the cost of this item.

Basis of Payment. This work will be paid for at the Contract unit price per Foot of COMBINATION CONCRETE CURB AND GUTTER, TYPE B-6.12.

ITEM #22: CONCRETE BARRIER CURB, TYPE B

Description. This work shall be according to Article 606 of the Standard Specifications and the following:

Concrete barrier curb shall be constructed at the general locations shown on the Plans, or as directed by the Engineer, and in accordance with the details shown on the Plans. The proposed curb shall be installed upon a four inch (4”) bedding of crushed stone. The installation of this bedding shall be included in the cost of this item.

Three-quarter inch ($\frac{3}{4}$ ”) bituminous expansion joint fillers with two (2) smooth, round, capped, epoxy coated, steel dowel bars each $\frac{3}{4}$ ” in diameter and 18” long shall be placed at intervals not to exceed 60’ and at locations designated by the engineer.

After removal of the “back of curb” form, all areas shall be immediately backfilled with crushed aggregate, gradation CA-7 or CA-11. The placement of the required backfill material shall be included in the cost of this item.

Basis of Payment. This work will be paid for at the Contract unit price per Foot of CONCRETE BARRIER CURB, TYPE B.

ITEM #23: PORTLAND CEMENT CONCRETE SIDEWALK, 5”

Description. This work shall be according to Article 424 of the Standard Specifications and the following:

The five inch (5”) thick Portland Concrete Cement (P.C.C.) sidewalk shall be constructed to the limits and grade required to blend with adjoining surfaces. The sidewalk shall be placed upon a base of compacted crushed stone, Gradation CA-6, having a minimum thickness of four inches (4”). The installation of this bedding shall be included in the cost of this item. Full depth expansion joints shall be placed between the sidewalk and the back of any adjacent curb, sidewalk, or buildings, and as directed by the Engineer.

Steel forms will not be allowed.

Basis of Payment. This work will be paid for at the Contract unit price per Square Foot for PORTLAND CEMENT CONCRETE SIDEWALK, 5”.

ITEM #24: DETECTABLE WARNINGS

Description. This work shall be according to Article 424 of the Standard Specifications and the following:

Work shall be performed according to the Americans with Disabilities Act, IDOT Standard 424001-07.

The detectable warning shall be approved by the Engineer. This item shall be cast in place and shall not be a “Surface Applied” product.

Immediately following the installation of PORTLAND CEMENT CONCRETE SIDEWALK, 5”, the detectable warning shall be pressed into the concrete. The detectable warning shall be tamped with a vibrating mechanism upon installation, and the factory-installed plastic sheeting must remain in place during the entire installation process to prevent the splashing of concrete onto the finished surface of the tile. No concrete shall be removed in the area to receive the detectable warning to ensure a strong lock with the concrete. The top of the domes shall be set level to the adjacent concrete on the top and sides of the ramp. This item shall be installed in full accordance with the manufacturer’s recommendations.

Basis of Payment. This work will be paid for at the Contract unit price per Square Foot for DETECTABLE WARNINGS.

ITEM #25: PORTLAND CEMENT CONCRETE DRIVEWAY PAVEMENT, 6”

Description. This work shall be according to Article 423 of the Standard Specifications and the following:

This item includes the placement of new concrete driveway pavement at locations shown on the Plans and as designated by the Engineer. The driveway shall be placed upon a cushion of compacted crushed stone, Gradation CA-6, having a minimum thickness of four inches (4”). The installation of this bedding shall be included in the cost of this item. The Engineer shall determine the limits and joint patterns of proposed driveway areas.

Full-depth (6”), bituminous expansion joint fillers (3/4” thick) shall be placed along all proposed curb and gutter and along all existing sidewalk.

Basis of Payment. This work will be paid for at the Contract unit price per Square Yard for PORTLAND CEMENT CONCRETE DRIVEWAY PAVEMENT, 6”.

ITEM #26 PORTLAND CEMENT CONCRETE DRIVEWAY PAVEMENT, 8”

Description. This work shall be according to Article 423 of the Standard Specifications and the following:

This item includes the placement of new concrete driveway pavement at commercial locations shown on the Plans and as designated by the Engineer. The driveway shall be placed upon a cushion of compacted crushed stone, Gradation CA-6, having a minimum thickness of six inches (6”). The installation of this bedding shall be included in the cost of this item. The Engineer shall determine the limits and joint patterns of proposed driveway areas.

Full-depth (8”), bituminous expansion joint fillers (3/4” thick) shall be placed along all proposed curb and gutter and along all existing sidewalk.

Basis of Payment. This work will be paid for at the Contract unit price per Square Yard for PORTLAND CEMENT CONCRETE DRIVEWAY PAVEMENT, 8”.

ITEM #28: GEOTECHNICAL FABRIC FOR GROUND STABILIZATION

Description. This work shall be according to Article 210 of the Standard Specifications and the following:

This item shall consist of installing a woven geotextile fabric on the subgrade for the proposed pavements to be reconstructed as part of this Project. The fabric shall be GTF 200 as manufactured by LINQ Industrial Fabrics, Inc. The fabric shall be installed in accordance with the manufacturer’s instructions.

The fabric shall be staked in place to avoid any movement of the fabric during the placement of the aggregate base course and shall be extended one foot (1') behind the back of curb on each side.

Basis of Payment. This work will be paid for at the Contract unit price per Square Yard for GEOTECHNICAL FABRIC FOR GROUND STABILIZATION.

ITEM #30: AGGREGATE FOR TEMPORARY ACCESS

Description. This work shall be according to Article 402 of the Standard Specifications and the following:

The material is to be used to construct and maintain an aggregate surface course for temporary roads and entrances. When use of the temporary aggregate is discontinued it shall be removed and utilized in the permanent construction (if approved by the Engineer) or disposed of.

The maintenance of each entrance shall be included in the cost of this item. Each entrance will only be paid for once, regardless of duration of usage.

An allowance has been made within the bid for this item however it is expected that the Contractor will re-use this material elsewhere within the project where possible.

Basis of Payment. This work will be paid for at the contract unit price per Each for AGGREGATE FOR TEMPORARY ACCESS which price shall include its installation and removal.

ITEM #31: BITUMINOUS MATERIALS (TACK COAT)

Description. This work shall be according to Article 406 of the Standard Specifications and the following:

This item includes the application of a bituminous tack coat (SS-1) on the existing or proposed base course on all streets and as directed by the Engineer. The prime coat shall be at least one hour before and no more than 2 days before the start of paving operations.

The Contractor shall be responsible for placing warning signs at all points of access to the primed surface except for residential driveways.

Basis of Payment. This work will be paid for at the Contract unit price per Pound for BITUMINOUS MATERIALS (TACK COAT).

ITEM #32: HOT-MIX ASPHALT DRIVEWAY PAVEMENT, 4”

Description. This work shall be according to Article 406 of the Standard Specifications and the following:

Existing asphalt driveways which are slated to be replaced shall be surfaced with a four inch (4”) thickness of hot-mix asphalt surface course. The asphalt must be placed in two lifts of two inches (2”) each.

This item will include the preparation of existing pavement including the installation, compacting and priming of the aggregate base. The driveway shall be placed upon a cushion of compacted crushed stone, gradation CA-6, having a minimum thickness of six inches (6”). The installation of this bedding shall be included in the cost of this item.

The material shall meet the requirements of Hot-Mix Asphalt Surface Course, Mix “D” N50, as described in the Standard Specifications and as shown in the chart on the plans.

The crushed stone surfaces and/or the concrete surface shall be cleaned and then primed with RC-70 bituminous material at a rate of 0.20 to 0.30 gallons per square yard immediately prior to the laying of the asphalt mixture. A self-propelled mechanical roller shall be used to compact the hot-mix asphalt surface course.

Basis of Payment. This work will be paid for at the Contract unit price per Square Yard for HOT-MIX ASPHALT DRIVEWAY PAVEMENT, 4”.

ITEM #33: HOT-MIX ASPHALT DRIVEWAY PAVEMENT, 6”

Description. This work shall be according to Article 406 of the Standard Specifications and the following:

Existing asphalt driveways which are slated to be replaced shall be surfaced with a four inch (6”) thickness of hot-mix asphalt surface course. The asphalt must be placed in two lifts of two inches (3”) each.

This item will include the preparation of existing pavement including the installation, compacting and priming of the aggregate base. The driveway shall be placed upon a cushion of compacted crushed stone, Gradation CA-6, having a minimum thickness of six inches (8”). The installation of this bedding shall be included in the cost of this item.

The material shall meet the requirements of Hot-Mix Asphalt Surface Course, Mix “D” N50, as described in the Standard Specifications and as shown in the chart on the plans.

The crushed stone surfaces and/or the concrete surface shall be cleaned and then primed with RC-70 bituminous material at a rate of 0.20 to 0.30 gallons per square yard

immediately prior to the laying of the asphalt mixture. A self-propelled mechanical roller shall be used to compact the hot-mix asphalt surface course.

Basis of Payment. This work will be paid for at the Contract unit price per Square Yard for HOT-MIX ASPHALT DRIVEWAY PAVEMENT, 6”.

ITEM #34: CLASS D PATCHES, TYPE I-IV, 6”

Description. This work shall be according to Article 442 of the Standard Specifications and the following:

This item will primarily consist of the removal of the existing hot-mix asphalt and a portion of the aggregate or concrete base and replacement with hot-mix asphalt at locations shown on the Plans or as directed by the Engineer.

All references to types of patches in the Standards Specifications shall be removed.

The material will be removed to a depth sufficient to result in six inches (6”) of hot-mix asphalt placement. The material shall be Hot-Mix Asphalt Binder, IL 19.0, and be placed in two lifts with minimum thickness of 2.5”.

The limits of removal shall be marked by the Engineer. The patches shall be saw cut full-depth and any areas damaged outside the limits of removal shall be replaced by the Contractor at his own expense.

Basis of Payment. This work will be paid for at the Contract Unit Price per Square Yard for CLASS D PATCHES, TYPE I-IV, 6”.

ITEM #37: HOT-MIX ASPHALT SURFACE COURSE, MIX D, N50

Description. This work shall be according to Article 406 of the Standard Specifications and the following:

This item shall be applied to all pavements to be surfaced. The Hot-Mix Asphalt surface course shall be installed with a nominal thickness of two-inches (2”). This will allow for the finished pavement to be ¼” above the curb gutter at the edge of pavement. All work shall be in accordance with Section 406 of the Standard Specifications.

The surface course shall be placed on the newly installed binder or leveling binder no more than ten (10) days after the level binder and binder has been placed. If the surface has not been placed within ten (10) days after binder, the Contractor will be assessed liquidated damages for each day in excess of ten (10) days at the same rate as specified for completion of the Contract in the Bid Proposal.

This item will also be used for the paving of butt-joints.

Basis of Payment. This work will be paid for at the Contract unit price per Ton for HOT-MIX ASPHALT SURFACE COURSE, MIX D, N50.

ITEM #38: TOPSOIL FURNISH AND PLACE, 4"

Description. This work shall be according to Article 211 of the Standard Specifications and the following:

The Contractor shall take precautions so as not to unnecessarily damage lawns. In areas that are designated to be sodded, the existing sod shall be cut and removed; the area shall then be shaped, graded and rototilled. The area to be sodded shall then have a layer of good quality, pulverized topsoil which has been approved by the Engineer prior to placement, spread and fine raked in such a manner as to result in a top dressing of the parkway having an average thickness of four inches (4") of topsoil.

Any excavation and grading of the parkway which is required to give a uniform slope from the limit of sod restoration to the top of the curb shall be included in this item. Unless otherwise directed by the Engineer, the topsoil and sod shall be placed after the installation of the binder or leveling binder and before the installation of the hot-mix asphalt surface course.

The Contractor shall be responsible for removing any weeds prior to the placement of the sod. The method of weed removal must be approved by the Engineer.

The topsoil and subgrade shall be thoroughly compacted along newly installed concrete by a compaction method approved by the Engineer. If proper compaction is not achieved, the Engineer may direct the Contractor to remove any soil backfill that the Contractor has placed and replace it with a granular stone backfill. This will be included in the cost of this item.

Water service boxes and valve boxes that can be adjusted to final grade without replacement parts shall be included in the cost of this item.

Basis of Payment. This work will be paid for at the Contract unit price per Square Yard for TOPSOIL FURNISH AND PLACE, 4".

ITEM #39: SODDING

Description. This work shall be according to Article 252 of the Standard Specifications and the following:

This item shall consist of the placement of sod on all landscaped areas disturbed by construction as shown on the Plans or as directed by the Engineer. Any excessive or unnecessary damage to the parkway will be restored by the Contractor at his own expense.

After the parkway areas designated for sodding have received the layer of topsoil, the areas shall be carefully graded, fine-raked, rolled, and then covered with a good quality of grass sod. Kentucky Blue or Merion Blue sod shall be used in sodding the parkways. The minimum area of any piece of sod to be placed shall be one (1) square foot with no side being less than six inches (6") in length.

The Contractor shall be responsible for watering the sod in accordance with Section 252 of the Standard Specifications. Upon completion of the 30 day period, the Contractor shall notify the Engineer in writing and request an inspection. The Engineer shall inspect the sod and shall supply the Contractor with a written punch list of any areas that are found unacceptable.

Basis of Payment. This work will be paid for at the Contract unit price per Square Yard of SODDING.

ITEM #42: INLET FILTERS

Description. This work shall consist of installing, maintaining and cleaning inlet filters as shown on the plans or as directed by the Engineer. This work shall be in accordance with Section 280 of the Standard Specifications, except as modified herein.

Inlet filters shall consist of metal frames with attached fabric bags. Contractor shall furnish inlet filters of appropriate sizes and shapes necessary to accommodate all different types of drainage structures encountered. The use of filter fabric without a frame will not be an acceptable material for inlet filters and will be rejected.

Contractor shall inspect and clean all inlet filters weekly, after every rainfall, and additionally as needed. Maintenance and cleaning of inlet filters will not be paid for separately but shall be included in the cost of this work.

Method of Measurement. This work will be measured for payment as each individual inlet filter installed and the unit of measurement will be each. No measurement will be made of maintenance and cleaning efforts. If an inlet filter is installed on multiple structures the inlet filter will only be measured for payment once.

Basis of Payment. This work will be paid for at the contract unit price per each for INLET FILTERS.

ITEM #43: TRENCH BACKFILL

Description. This work shall be according to Article 208 of the Standard Specifications and the following:

The material used for trench backfill shall be CA-6. The trench backfill shall be compacted only by Method 1 as defined in Article 550.07 of the Standard Specifications. Recycled materials or crushed concrete will not be permitted.

The standard test to define maximum densities of all compaction work shall be ASTM D-1557. All densities shall be expressed as a percentage of the maximum density obtained in the laboratory by the ASTM D-1557 standard procedure. Each layer shall be compacted by mechanical means to 95 percent of the maximum dry density.

Construction Requirements. The bedding, haunching and backfilling for pipe installation shall be as shown on the Drawings and as specified in Section 20 of the Water and Sewer Specifications except as modified in these Special Provisions. Bedding and haunching material will not be measured for payment but will be considered included in the cost of the associated pipe. The granular material required for initial backfill, from the spring-line of the pipe to 12 inches above the pipe, will not be eligible for payment but shall be considered included in the cost of the pipe.

For bedding and haunching requirements, refer to the pipe bedding details shown in the plans and associated specifications found in these Special Provisions.

Trench backfill shall be installed at locations shown in the Drawings to the existing finished grade elevation. The select granular backfill material shall be placed and compacted in 12-inch maximum layers of the specified materials as shown on the Drawings and installed from one foot above the top of the pipe to the existing finished grade.

Basis of Payment. This work will be paid for at the Contract unit price per Cubic Yard for TRENCH BACKFILL.

ITEM #44 & 45: STORM SEWERS, RCP, CL IV, ASTM C76

Description. This work shall be in accordance with Section 550 of the Standard Specifications and with the details in the plans, except as modified herein.

This work shall consist of constructing storm sewers at the locations and depths shown on the plans or as directed by the Engineer.

This work shall include trench excavation, hauling and disposal of excavated material, dewatering, sheeting, shoring, bracing, pipe bedding, pipe material and its installation, pipe gaskets, connections to structures, and earth backfill and compaction where permitted.

Materials. Storm sewer pipe shall be round reinforced concrete pipe conforming with ASTM C76/AASHTO M170 and shall be of adequate strength to support the trench loads applied.

Storm sewer pipe shall be furnished and installed with rubber gaskets conforming with ASTM C443/AASHTO M198. Storm sewer pipe shall be specifically constructed to fit the rubber gaskets which are used.

Basis of Payment. This work will be paid for at the Contract unit price per Foot for STORM SEWERS, RCP, CL IV, ASTM C76, of the diameter specified.

ITEM #46: 24" MANHOLE CONNECTION (CORE INTO EXISTING)

Description. This work shall consist of installing machine cored-in flexible couplings meeting ASTM C-923 into existing concrete structures to accommodate the installation of proposed sewers at locations as indicated on the plans or as directed by the ENGINEER.

Basis of Payment. This work will be paid for at the Contract unit price per Each for 24" MANHOLE CONNECTION (CORE INTO EXISTING).

ITEM #47: STORM MANHOLES, TYPE A, 4' DIAMETER, TYPE 1 FRAME, CLOSED LID

Description. This work shall be in accordance with Section 602 of the Standard Specifications and with the details in the plans, except as modified herein.

This work shall consist of constructing storm manholes at the locations and depths shown on the plans or as directed by the Engineer.

This work shall include excavation, hauling and disposal of excavated material, dewatering, sheeting, shoring, bracing, manhole bedding, manhole material and its installation, gaskets, trench backfill and earth backfill and compaction where permitted.

Materials. Manhole walls, transition slabs, cones, tops and base sections shall meet or exceed the requirements of ASTM C478.

Storm Manholes shall be installed with joint sealant made of butyl rubber material in flexible rope form in accordance with ASTM C-990. Approved products are EZ-Stik premium butyl sealant by Press Seal Corporation or equal.

Refer to General Special Provisions for specification of Frame and Lid.

Basis of Payment. This work will be paid for at the Contract unit price per Each for STORM MANHOLES, TYPE A, 4' DIAMETER, TYPE 1 FRAME, CLOSED LID.

ITEM #48: DOGHOUSE STORM MANHOLES, TYPE A, 7' DIAMETER, TYPE 1 FRAME, CLOSED LID

Description. This work shall be in accordance with Section 602 of the Standard Specifications and with the details in the plans, except as modified herein.

The installation and payment for this item shall be the same as STORM MANHOLES except for the designated difference in the size of the manhole and the installation of the base section. The construction details shall be as shown on the plans or as directed by the Engineer.

Basis of Payment. This work will be paid for at the Contract unit price per Each for DOG HOUSE STORM MANHOLES, TYPE A, 7' DIAMETER, TYPE 1 FRAME, CLOSED LID.

ITEM #49: SANITARY MANHOLES, TYPE A, 4' DIAMETER, TYPE 1 FRAME, CLOSED LID

Description. This work shall be in accordance with Section 602 of the Standard Specifications and with the details in the plans, except as modified herein.

This work shall include furnishing and installing precast manhole structures as shown on the Plans.

Materials. Materials to be new and provided in unopened containers where applicable.

The base shall be 6-inch nominal thickness and integral with the structure. Provide channels in invert to direct flows from incoming to outgoing pipe.

Flexible synthetic rubber boots meeting ASTM C-923 shall be installed on all pipe connections. Cast-in or pressed-on type boots are permitted. Cast-in type boot shall be installed in initial pouring of manhole section.

Walls shall be precast sections conforming to ASTM C478. Sections and component parts to be marked by manufacturer with trade name and/or trademark and ASTM designation. Wall thickness shall be 5" minimum. Holes shall be smooth, radial to centerline of manhole, and perpendicular to manhole wall.

Manhole opening shall be eccentric on cone.

All pre-cast manhole sections (wall and cone) are to be supplied with pre-applied coating of ConSeal CS-55 Water Based product or approved equal.

Joint sealant should be made of butyl rubber material in flexible rope form in accordance with ASTM C-990. Approved products are EZ-Stik premium butyl sealant by Press Seal Corporation or equal.

External chimney seals are to be installed on all new manholes. Acceptable external chimney seals include Infi-Shield or an approved equal.

All external joint sealing bands shall conform to ASTM C-877. Approved products are Type II MacWrap or approved equal. External joint seals shall consist of a collar 9 inches wide with an outer layer of polyethylene, with a minimum tensile strength of 4000 psi and a minimum tear resistance of 1500 psi, and an under layer of rubberized mastic that is reinforced with the collar 3/4 inches from the edge. The straps shall be confined in tubes that isolate them from the mastic and allow them to slip freely when mechanically tightened and locked around the manhole. The collar shall be furnished with a minimum 6 inches overlap and a closing flap to cover any remaining exposed strap.

Refer to General Special Provisions for specification of Frame and Lid.

Construction.

Place O-ring gasket or double row of extrudable pre-form plastic gasket between manhole sections. Place external Sealing Bands as shown on the detail at each joint between manhole sections in accordance with the manufacturer's instructions. Grout all lift holes from the inside and outside with a non-shrink grout, prior to backfilling.

Place appropriate top section, cone (depth > 6 feet). Place two adjusting rings maximum on manhole top.

Install manhole frame and cover and External Manhole Chimney Seal as shown on the detail, with extensions where needed to cover the entire chimney area, in accordance with the manufacturer's instructions. Provide digital photo of Manhole showing external chimney seal installed such that the manhole and its location are identified. For bolted cover provide bolts and ensure that the frame is securely fastened to the manhole.

Pour manhole invert. Provide poured-in-place channels (if manholes not furnished with precast inverts) to direct flows from in-coming pipes to outgoing pipes. Channels shall smoothly blend flows. Make channel horseshoe shaped. Width and depth equal to size of outlet sewer. To maintain flexibility of pipe connection boot, plug annular space between pipe and boot which falls in area where invert to be poured with extrudable preformed plastic gasket material. Plug shall prevent concrete from entering space between pipe and boot. Invert channels may be placed any time after manhole base section (and connecting pipe) is backfilled.

Any pipe including the mainline sewer up to four feet (4') in length per each pipe used to connect existing pipes to the proposed structure shall be included in the cost of the proposed structure. The pipe shall have a minimum standard dimension ratio (SDR) of

26 and shall conform to ASTM designation D-2241 (water quality pipe). Connections to existing sewer lines shall be made using non-shear Fernco RC Series or Mission Flex-Seal adjustable repair couplings equipped with stainless steel bands and shall be included in the cost of this item.

Basis of Payment. This work will be paid for at the Contract unit price per Each for SANITARY MANHOLES, TYPE A, 4' DIAMETER, TYPE 1 FRAME, CLOSED LID.

ITEM #50: ADJUSTING SANITARY SEWERS, 8" DIAMETER OR LESS

Description. This work shall be performed in accordance with Section 563 of the Standard Specifications, the "Standard Specifications for Water and Sewer Main Construction in Illinois," latest edition and applicable ordinances of the Village of Villa Park, with the following modifications:

This item shall only be used when the service is in direct conflict with the proposed sewer and approved by the Engineer. The existing sanitary service will be partially removed to an extent determined by the Engineer such that the proposed utility can be satisfactorily installed. The partially removed sanitary service will be immediately repaired with new material as described below once the proposed utility installation is complete.

This item does not cover damage created by the Contractor because of negligence. This item does not cover sewer adjustments that the Contractor elects to make to increase production or not approved by the Engineer. Any utility damaged due to Contractor's negligence will be repaired or replaced at Contractor's own expense.

Materials. Sanitary sewer shall be polyvinyl chloride (PVC) pipe with a Standard Dimension Ratio (SDR) of 26 conforming to ASTM D2241 with gasket joints conforming to ASTM 3212. All supplied pipes and fittings must be from the same manufacturer. Connections to existing sewer lines shall be made using non-shear Fernco RC Series or Mission Flex-Seal adjustable repair couplings equipped with stainless steel bands.

Basis of Payment. This work will be paid for at the Contract unit price per Foot for ADJUSTING SANITARY SEWERS, 8-INCH DIAMETER OR LESS.

ITEM #51: ADJUSTING WATERMAIN, 6"

Description. This work shall be performed in accordance with Section 561 of the Standard Specifications, the "Standard Specifications for Water and Sewer Main Construction in Illinois," latest edition and applicable ordinances of the Village of Villa Park, with the following modifications:

This work will only be paid for if the water main is in direct conflict with the proposed sewer and approved by the Engineer. This work shall include all materials and labor required to replace watermain.

Materials. Pipe shall be Ductile Iron conforming to AWWA C151 Class 52 standard thickness. Fittings shall be ductile iron in accordance with AWWA C110 or C151. Stainless steel bolts only.

Retainer glands shall be Megalug Series 1100 or equal in strength and retaining ability. Couplings for connecting new water main to existing water main shall be HYMAX GRIP restraint couplings by Krausz or approved equal.

Basis of Payment. This work will be paid at the Contract unit price per Foot for ADJUSTING WATERMAIN 6".

ITEM #52: ADJUSTING WATER SERVICE LINES

Description. This work shall be performed in accordance with Section 563 of the Standard Specifications, the "Standard Specifications for Water and Sewer Main Construction in Illinois," latest edition and applicable ordinances of the Village of Villa Park, with the following modifications:

Under this item the Contractor shall furnish all labor, materials and appurtenances necessary to adjust water services in direct conflict with the proposed sewer. This work must be approved by the Engineer before commencing. The Contractor shall make every attempt possible to avoid these facilities, and if in the opinion of the Engineer, the facilities are damaged due to carelessness by the Contractor, no compensation will be made for the replacement of same. The adjustment of the water service shall be determined by the Village or the Engineer.

If adjustment of certain services is necessary, the work shall be done in a workmanlike fashion, minimizing the downtime of the residents' services, and shall include all necessary labor and materials to properly complete the adjustment.

All material shall be manufactured in the United States. This item includes all sizes up to and including 1".

Water service line couplings shall be Mueller copper flare connection type conforming with ANSI/AWWA C800.

Copper water service pipe shall be installed a minimum of 5'-6" deep, and shall connect to the existing water service and a minimum of 18 inches outside the limits of the conflicting utility trench.

Copper water service pipe shall be Type "K" or greater copper tube, soft temper, for underground service, conforming to ASTM B-88 and B251. The pipe shall be marked with the manufacturer's name or trade mark and a mark indicative of the type of pipe.

Basis of Payment. This work will be paid for at the Contract unit price per Each for ADJUSTING WATER SERVICE LINES.

ITEM #53: WATER SERVICE REPLACEMENT

Description. This work shall be performed in accordance with Section 562 of the Standard Specifications, the "Standard Specifications for Water and Sewer Main Construction in Illinois," latest edition and applicable ordinances of the Village of Villa Park, with the following modifications:

This item shall include the installation of new water services and all necessary appurtenances from the existing water main to the property line or at a location as directed by the Engineer. This work will only be done when directed by the Engineer.

All material shall be manufactured in the United States. The installation of the new corporation stop and tapping sleeve shall be determined by the Village or the Engineer. This item includes all sizes up to and including 1".

The Contractor will be required to expose the existing corporation stop, remove the corporation stop, and install a Smith-Blair circle repair sleeve on the water main.

The water service installation shall start from the water main with a 1" corporation stop. The contractor shall install new connection fittings, 1" k-copper pipe, 1" curb stop, curb box (Minneapolis Pattern 1½", Mueller H10302), including excavation, bedding, and trench backfill with CA-6 as required to reach the property line.

Corporation stops shall be Mueller 300 Ball Corporation Valve Model B-25000 with AWWA taper (Mueller "CC") thread inlet and copper flare straight connection outlet.

Copper water service pipe shall be Type "K" or greater copper tube, soft temper, for underground service, conforming to ASTM B-88 and B251. The pipe shall be marked with the manufacturer's name or trade mark and a mark indicative of the type of pipe.

Water service line couplings shall be Mueller copper flare connection type conforming with ANSI/AWWA C800.

Copper water service pipe shall be installed a minimum of 5'-6" deep, and shall connect between the existing water service and new curb box and curb stop as needed.

Corporation stop and tapping sleeve shall be installed as needed in accordance with the standard details.

Basis of Payment. This work will be paid for at the Contract unit price per Each for WATER SERVICE REPLACEMENT.

ITEM #54: VALVE VAULTS, TYPE A, 4' DIAMETER, TYPE 1 FRAME, CLOSED LID

Description. This work shall be performed in accordance with Section 602 of the Standard Specifications, the "Standard Specifications for Water and Sewer Main Construction in Illinois," latest edition and applicable ordinances of the Village of Villa Park, with the following modifications:

The work will consist of installing valve vaults complete in place, including ASTM C-923 mechanical boot connection as shown in the detail on the Plans. This work shall include excavation; removal and disposal of waste excavated materials; protection, repair, or replacement of utilities; frames and lids; final adjustment of the frame to meet finished grade; joint protection; trench dewatering; erosion and siltation control methods and devices to protect the environment; backfilling with and compacting trench backfill material around the new vault; finish grading.

Basis of Payment. This work will be paid for at the Contract unit price per Each for VALVE VAULTS, TYPE A, 4' DIAMETER, TYPE 1 FRAME, CLOSED LID.

ITEM #55: WATER VALVES

Description. This work shall consist of constructing water valves. This work shall be in accordance with applicable portions of Section 561 of the Standard Specifications and with the Standard Specifications for Water and Sewer Construction in Illinois, except as modified herein.

Materials. Water valves shall be AMERICAN Flow Control Series 2500 Ductile Iron Resilient Wedge Gate Valves conforming to ANSI/AWWA C515, with mechanical joint end connections, of the diameter specified, or approved equal. All exterior valve body bolting shall be Type 304 stainless steel.

Water main pipe shall be ductile iron pipe conforming to ANSI/AWWA C151/A21.51, Class 52 standard thickness, with push-on joints conforming to AWWA C111.

Water main couplings shall be Krausz Hymax Grip coupling restraints of the diameter required, or approved equal.

Mechanical joint restraints shall be EBAA Iron, Inc., MEGALUG Mechanical Joint Restraints for Ductile Iron Pipe, or approved equal.

All bolts, nuts, washers, and other hardware to be installed below grade shall be Type 304 stainless steel.

Construction. Water valves shall be installed in a pre-cast concrete valve vault unless otherwise specified. The valve shall be placed on a solid concrete block resting on the bottom of the valve vault. The valve shall be placed so that the operating nut is centered under the opening of the valve vault.

Where a new water valve is to be installed on an existing water main, the existing water main shall be cut by an approved method and a section of existing water main of sufficient length shall be removed. The valve shall be joined on both ends to sections of new water main pipe of the proper length with mechanical joint restraints. The valve and pipe assembly shall be positioned in place between the two cut ends of the existing water main and the ends of the existing water main shall be joined to the valve assembly with water main couplings of the proper size. The labor, equipment and materials which are necessary to construct a new water valve on an existing water main will not be paid for separately but shall be included in the cost of this work.

Where an existing water valve is to be removed and replaced with a new water valve in substantially the same location, removal of the existing water valve and water valve vault or box will not be paid for separately but shall be included in the cost of this work.

Excavation, bedding, and backfilling needed for the installation of water valves will not be paid for separately but shall be included in the cost of this work.

Basis of Payment. This work will be paid for at the contract unit price per each for WATER VALVES, of the diameter specified.

ITEM #56: CONNECTION TO EXISTING WATER MAIN

Description. This work shall consist of making non-pressure, cut-in connections to existing water mains. This work shall be in accordance with Section 561 and Section 563 of the Standard Specifications and with the Standard Specifications for Water and Sewer Construction in Illinois, except as modified herein.

Materials. Water main pipe shall be ductile iron pipe conforming to ANSI/AWWA C151/A21.51, Class 52 standard thickness, with push-on joints conforming to AWWA C111, of the diameter required.

Water main fittings shall be ductile iron conforming to ANSI/AWWA C110/A21.10 or ANSI/AWWA C153/A21.53. Fittings shall be cement mortar lined and tar coated in accordance with AWWA C104. Fittings shall have mechanical joint end connections unless otherwise specified. Fittings shall include tees, crosses, reducers, and all other fittings as may be necessary to construct a connection to an existing water main.

Water main couplings shall be Krausz Hymax Grip coupling restraints of the diameter required, or approved equal.

Mechanical joint restraints shall be EBAA Iron, Inc., MEGALUG Mechanical Joint Restraints for Ductile Iron Pipe, or approved equal.

All bolts, nuts, washers, and other hardware to be installed below grade shall be Type 304 stainless steel.

Construction. The connection to the existing water main shall be accomplished by the use of fittings of the proper types and sizes, sections of new water main pipe of the proper lengths and diameters, water main couplings of the proper sizes, and mechanical joint restraints. The connection shall be made in the most direct configuration possible. The connection may be made to the existing water main or to existing valves or fittings.

Thrust blocking of all fittings shall be in accordance with Article 41-2.08 of the Water and Sewer Specifications and the details in the plans.

The water main pipe and fittings shall be placed on a bedding of crushed aggregate of CA-7 or CA-11 gradation having a minimum thickness of 4 inches. The bedding shall be placed to a minimum of 12 inches above the water main pipe and fittings.

Excavation, bedding, and backfilling will not be paid for separately but shall be included in the cost of this work.

Method of Measurement. This work will be measured for payment as each connection made, regardless of the depth of the connection, the number or type of fittings required, or any other factors. No separate measurement will be made of pipe, fittings, couplings, hardware, or any other components.

Basis of Payment. This work will be paid for at the contract unit price per each for CONNECTION TO EXISTING WATER MAIN, of the diameter specified.

ITEM #57: FIRE HYDRANTS TO BE REMOVED

Description. This work shall consist of removing fire hydrants in locations where new fire hydrants are not to be installed. This work shall be in accordance with Section 564 of the Standard Specifications and with the Standard Specifications for Water and Sewer Construction in Illinois, except as modified herein.

Where an existing fire hydrant is to be removed and replaced with a new fire hydrant in substantially the same location, removal of the existing fire hydrant will not be paid for separately but shall be included in the cost of the fire hydrant installation.

Materials. Water main pipe shall be ductile iron pipe conforming to ANSI/AWWA C151/A21.51, Class 52 standard thickness.

Water main couplings shall be Krausz Hymax Grip coupling restraints of the diameter required, or approved equal.

All bolts, nuts, washers, and other hardware to be installed below grade shall be Type 304 stainless steel.

Construction. The existing fire hydrant, auxiliary valve, valve box, hydrant lead, tee, and a portion of the adjoining water main shall be excavated and exposed. The existing water main shall be cut on both sides of the tee by an approved method and a section of existing water main shall be removed along with the tee, hydrant lead, valve box, auxiliary valve and fire hydrant. A section of new water main pipe of the proper length shall be positioned in place between the two cut ends of the existing water main and the ends of the existing water main shall be joined to the new section of water main pipe with water main couplings of the proper size.

The excavation shall be backfilled with crushed aggregate of CA-6 gradation and mechanically compacted in lifts not exceeding 12 inches.

Excavation and backfilling will not be paid for separately, but shall be included in the cost of this work.

Fire hydrants which are removed and are selected by the Engineer to be salvaged shall remain the property of the Village and shall be delivered by the Contractor to the Village of Villa Park Public Works Department yard located at 51 South Ardmore Avenue in Villa Park. Delivery shall be made during the normal working hours of the Village of Villa Park Public Works Department and the Contractor shall coordinate the day, time and other details of delivery with the Village. Fire hydrants which are not selected by the Engineer to be salvaged shall become the property of the Contractor and shall be removed from the site by the end of the workday and properly disposed of by the Contractor. The delivery or disposal of fire hydrants will not be paid for separately but shall be included in the cost of this work.

Basis of Payment. This work will be paid for at the contract unit price per each for FIRE HYDRANTS TO BE REMOVED.

ITEM #58: FIRE HYDRANT WITH AUXILIARY VALVE AND VALVE BOX

Description. This work shall consist of constructing fire hydrants with auxiliary valves and valve boxes. This work shall be in accordance with Section 564 of the Standard Specifications and with the Standard Specifications for Water and Sewer Construction in Illinois, except as modified herein.

Materials. Fire hydrants shall be AMERICAN Flow Control 5-1/4" Waterous Pacer Fire Hydrant Model WB67-250, conforming to ANSI/AWWA C502, 6' – 0" bury depth, with all stainless steel trim, above-ground breakable flanges, and auxiliary resilient wedge gate

valve and valve box. Fire hydrants shall be fitted with DDP-arrangement nozzle sections with one 4-½ inches pumper nozzle and two 2-½ inches hose nozzles with National Standard threads and a National Standard operating nut.

Fire hydrants shall be factory painted red, prime coated with an epoxy, and finish coated with a two-part polyurethane top coat. Fire hydrants that are not factory painted red will be considered unacceptable and will be rejected.

Fire hydrants which are to be constructed on existing water mains where a 6' – 0" bury depth is incompatible with the depth of the existing water main shall be substituted with a fire hydrant of a different bury depth as approved by the Engineer.

Auxiliary valves shall be AMERICAN Flow Control Series 2500 Ductile Iron Resilient Wedge Gate Valves conforming to ANSI/AWWA C515, with mechanical joint end connections, 6 inches diameter. All exterior valve body bolting shall be Type 304 stainless steel.

Valve boxes shall have a cover embossed with the word "WATER".

Hydrant lead pipe shall be ductile iron pipe conforming to ANSI/AWWA C151/A21.51, Class 52 standard thickness, with push-on joints conforming to AWWA C111, 6 inches diameter.

Mechanical joint restraints shall be EBAA Iron, Inc., MEGALUG Mechanical Joint Restraints for Ductile Iron Pipe, or approved equal.

Valve box stabilizer grips shall be by BLR Enterprises, Inc., or approved equal.

All hardware and fasteners to be installed below grade shall be stainless steel. Bolts and threaded rods shall be Type 304 stainless steel and nuts and washers shall be Type 300 stainless steel.

Fire hydrant barrel extensions, if permitted, shall be AMERICAN Flow Control Waterous Series and shall be a maximum of 18 inches.

Construction. Where an existing fire hydrant is to be removed and replaced with a new fire hydrant with auxiliary valve and valve box in substantially the same location, the existing fire hydrant, auxiliary valve, valve box, hydrant lead pipe, and tee shall be excavated and exposed. The existing hydrant lead pipe shall be disconnected from the existing tee and the existing fire hydrant, auxiliary valve, valve box, and hydrant lead pipe shall be removed. Removal of the existing fire hydrant and related components will not be paid for separately but shall be included in the cost of this work.

If the Engineer determines the existing hydrant tee and adjoining connections are in satisfactory condition, then the existing tee shall be reused, except that all of the hardware on the existing tee shall be replaced. If the Engineer determines the existing hydrant tee

is in unsatisfactory condition, then the existing tee shall be removed and replaced and this work will be performed, measured and paid for as CONNECTION TO EXISTING WATER MAIN.

The fire hydrant shall be installed so that the standpipe is plumb. The center of the lowest nozzle shall be placed at least 18 inches but not more than 24 inches above finished grade. The breakable flanges shall be positioned 2 in. above finished grade. The nearest part of the hydrant shall be at least 3 feet, but not more than 8 feet. behind the back of curb. The nearest part of the hydrant shall be at least 3 feet from all paved surfaces. Where hydrants are to be installed adjacent to a roadway they shall be placed so that the pumper nozzle faces the roadway and is perpendicular to the direction of travel of the roadway. Where hydrants are not to be installed adjacent to a roadway they shall be placed according to the plans or as directed by the Engineer.

Fire hydrants and auxiliary valves shall be set on a firm foundation of precast concrete blocks and shall be thrust blocked. Additional precast concrete bricks shall be placed under the auxiliary valve as needed. Thrust blocking shall consist of Class SI concrete cast in place against the fittings and the undisturbed earth on any side or sides of the excavation where thrust is expected to occur. A minimum of $\frac{1}{4}$ cu.yd. of concrete shall be used for the thrust blocking. The dimensions of the thrust blocking shall be determined by the Engineer. Thrust blocking may also consist of the placement of precast concrete blocks at the discretion of the Engineer. Additional precast concrete blocks shall be placed on the bottom, back and sides of the hydrant as directed by the Engineer to hold the hydrant solid and vertical. All blocks, bricks and thrust blocking shall be placed such that the pipe, joints and fittings shall be accessible for future repair and so that the hydrant drain holes are not blocked.

Mechanical joint restraints shall be installed on all mechanical fittings. Stainless steel threaded tie rods shall be installed between the fire hydrant barrel and the tee fitting on the water main. Valve box stabilizer grips shall be installed. Barrel extensions will only be permitted at the discretion of the Engineer.

Fire hydrants shall be braced during backfilling. The area around the base of the hydrant shall be backfilled with a minimum of 1 cu.yd. of washed stone. The washed stone shall be covered with polyethylene sheeting prior to further backfilling. Backfill material shall be placed in lifts not exceeding 6 inches in thickness, loose measurement, and compacted in a manner approved by the Engineer.

Fire hydrants not in service shall be covered with plastic bags until the fire hydrants are in service.

Excavation, bedding, and backfilling of fire hydrants will not be paid for separately but shall be included in the cost of this work.

Method of Measurement. This work will be measured for payment as each fire hydrant with auxiliary valve and valve box installed. No separate measurement will be made of pipe, fittings, hardware, or any other components.

Basis of Payment. This work will be paid for at the contract unit price per each for FIRE HYDRANT WITH AUXILIARY VALVE AND VALVE BOX.

ITEM #59: WATER USAGE DEDUCTION

Description. ITEMS are provided as a part of this contract for the purpose of documenting the quantity of water obtained from the Village by the Contractor.

If the Contractor elects to obtain water from the Village, the Contractor shall comply with the Special Provision USE OF FIRE HYDRANTS. The quantity of water obtained from the Village by the Contractor shall be deducted from the contract as WATER USAGE DEDUCTION, and shall be credited to the contract as WATER USAGE CREDIT.

The WATER USAGE DEDUCTION ITEM for this contract has been established with a unit of measurement in thousands of gallons (TGAL), a quantity of one hundred (100.00), and a contract unit price of a deduction of eight dollars and eighty five cents (\$8.85), for a total WATER USAGE DEDUCTION contract price of a deduction of eight hundred eighty five dollars and no cents (\$885.00). Bidder, in submitting a bid, accepts the quantity, contract unit price, and total contract price of the WATER USAGE DEDUCTION ITEM.

Method of Measurement. Water usage will be measured as the actual quantity of water obtained from the Village by the Contractor, which quantity shall be rounded up to the nearest 1,000 gallons.

Basis of Payment. The water usage deduction will be deducted at the contract unit price per Thousand Gallons (TGAL) for WATER USAGE DEDUCTION. The quantity deducted as WATER USAGE DEDUCTION will be equal to the quantity paid for as WATER USAGE CREDIT.

ITEM #60: WATER USAGE CREDIT

Description. ITEMS are provided as a part of this contract for the purpose of documenting the quantity of water obtained from the Village by the Contractor.

If the Contractor elects to obtain water from the Village, the Contractor shall comply with the Special Provision USE OF FIRE HYDRANTS. The quantity of water obtained from the Village by the Contractor shall be deducted from the contract as WATER USAGE DEDUCTION, and shall be credited to the contract as WATER USAGE CREDIT.

The WATER USAGE CREDIT ITEM for this contract has been established with a unit of measurement in thousands of gallons (TGAL), a quantity of one hundred (100.00), and a contract unit price of eight dollars and eighty five cents (\$8.85), for a total WATER USAGE CREDIT contract price of eight hundred eighty five dollars and no cents (\$885.00). Bidder, in submitting a bid, accepts the quantity, contract unit price, and total contract price of the WATER USAGE CREDIT ITEM.

Method of Measurement. Water usage will be measured as the actual quantity of water obtained from the Village by the Contractor, which quantity shall be rounded up to the nearest 1,000 gallons.

Basis of Payment. The water usage credit will be paid for at the contract unit price per Thousand Gallons (TGAL) for WATER USAGE CREDIT. The quantity paid for as WATER USAGE CREDIT will be equal to the quantity deducted as WATER USAGE DEDUCTION.

ITEM #62: PRE-CONSTRUCTION VIDEO RECORDING

Description. This work consists of performing color video and audio recording of the project area and other areas which may be impacted by construction.

Preconstruction video recordings will include coverage of the project area and all other areas which may be impacted by construction. Video recordings will also include construction easements when applicable. Video recordings will provide a visual record of all physical features within those areas, including, but not limited to, roadways, pavements, curbs, gutters, driveways, driveway aprons, sidewalks, carriage walks, parkways, trees, landscaping, shrubbery, plantings, landscaping walls, retaining walls, signs, sign posts, fences, utility poles, light poles, utilities, equipment, manholes, b-boxes, cleanouts, valves, curb structures, pipelines, buildings, mailboxes, and any other features located within the project area.

Video recordings will begin with an audio narrative which provides the current date and time, the name of Owner and name of project, and a description of both the starting location and the location or locations to be recorded, including street name or names, street addresses, and any additional information which may be necessary to describe the location and subject of viewing.

Video recordings will maintain viewer orientation by means of an audio commentary in the audio track of each video recording which provides an explanation of what is being viewed; and by videotaping landmarks and readily identifiable objects (property addresses, street signs, etc.) at appropriate intervals.

Preconstruction video recordings will be recorded at a rate of travel not exceeding 48 feet per minute, and zooming and panning rates will be controlled to provide clarity of features during playback. The finished product will be provided with bright, clear pictures and accurate colors free from distortion, tearing, rolls, or other forms of picture imperfection.

The audio will have proper volume and clarity. All recordings will be performed at times of satisfactory visibility, and when no more than ten percent of ground is obscured by snow, leaves, or other cover.

If any element within or portion of the project area is not adequately documented by the preconstruction video recording so as to definitively demonstrate its condition prior to the start of construction, Contractor will assume responsibility for the repair, restoration or replacement of that element or portion of the project area. Such repair, restoration or replacement will be to equal or better condition than previously existing, and will further comply with all standards and provisions which govern the work in question.

Schedule. Preconstruction video recording will be performed according to the following schedule:

- (a) Preconstruction video recording will take place after a Notice to Proceed has been issued.
- (b) Preconstruction video recording will take place after the Joint Utility Locating Information for Excavators (JULIE) request for the project area has cleared.
- (c) Preconstruction video recording will take place before any equipment, materials, or other items are delivered to the site.
- (d) Preconstruction video recording will take place no more than seven (7) chargeable days prior to the start of construction.
- (e) Preconstruction video recording will take place, the required pre-construction video recording deliverables will be submitted to the Engineer, and the Engineer will review and issue written approval of the video before any activity other than utility locating will be permitted to start. Such activity will include, but not be limited to, delivery of materials and equipment, installation of traffic control and erosion control, and completion of construction layout and tree protection. No days will be charged against the contract time while the video is under review by the Engineer, including the day the deliverables are submitted and the day a response is provided. If the video or any portions thereof are rejected, the contract time will commence to run until revisions are submitted.
- (f) The recording will be submitted to Engineer for review prior to commencement of any construction, and receive acceptance of recordings prior to commencement of construction. Any areas found not acceptable to the Owner will be re-filmed at no additional cost to the contract.

Deliverables.

Video will be high-definition, with a minimum resolution of 1280 x 720 pixels per frame. Video will be filmed in a landscape aspect ratio. Video filmed in a portrait aspect ratio will be considered unacceptable and will be rejected.

Preconstruction video recordings will be provided as electronic files of .avi, .mp4, .m4v, .mkv, .wmv, or .mpg file format, or of such other file format as may be approved by Engineer. Preconstruction video recordings will be provided as independent digital container format files, which container files will include all video, audio, and other electronic information necessary to view the preconstruction video recording as intended.

Video DVD will be considered an unacceptable format for providing preconstruction video recordings, and will be rejected.

Preconstruction video recording electronic files will be provided on a portable electronic media device or devices of one of the following types: USB flash drive, SD flash memory card, CF flash memory card, data DVD, external hard drive, or such other portable electronic media device as may be approved by Engineer. Preconstruction video recording electronic files may also be provided via online file sharing, cloud storage, File Transfer Protocol (FTP), or other online or network file transfer methods if approved by Engineer.

Preconstruction video recording electronic files will be accompanied by corresponding logs which document the dates, times, and locations covered by each preconstruction video recording electronic file.

Contractor shall maintain copies of all items submitted to Engineer for Contractor's own use and record.

Method of Measurement. This work will be measured for payment on a lump sum basis. No measurement will be made of the individual components of this effort.

Basis of Payment. This work will be paid for at the Contract lump sum price for PRECONSTRUCTION VIDEO RECORDING.

ITEM #63: CONSTRUCTION LAYOUT

Description. This work shall be in accordance with the Recurring Special Provisions for construction layout stakes with the following modifications:

The contract lump sum price for CONSTRUCTION LAYOUT must not be more than 2% of the Contract price.

Basis of Payment. This work will be paid for at the Contract lump sum price for CONSTRUCTION LAYOUT.

ITEM #64: TRAFFIC CONTROL AND PROTECTION

Description. This work shall consist of the furnishing, installation, maintenance, relocation, and removal of work zone traffic control and protection. This work shall be in accordance with Section 701 of the Standard Specifications, the Supplemental Specifications, the "Illinois Manual of Uniform Traffic Control Devices", the Highway Standards and details contained in the Plans and Special Provisions, and the Special Provisions contained herein, except as modified herein.

The bid price for TRAFFIC CONTROL AND PROTECTION shall not exceed 5 percent of the total bid price. If the bid price for TRAFFIC CONTROL AND PROTECTION exceeds 5 percent of the total bid price, the Village may reject the Bid.

Special Attention is called to Article 107.09 of the Standard Specifications and the following Highway Standards, Details, Recurring Local Roads and Streets Special Provisions, and Special Provisions contained herein, relating to traffic control.

HIGHWAY STANDARDS: 701301, 701501, 701801, 701901

DETAILS:

- Traffic Control and Protection for Side Roads, Intersections, and Driveways (TC-10)

SPECIAL PROVISIONS (Included in these Special Provisions):

- Maintenance of Roadways
- Work Zone Traffic Control Surveillance (LRS 3)
- Flaggers in Work Zones (LRS 4)
- Sidewalk, Corner, or Crosswalk Closure (BDE)

Contractor shall contact the Village at least 72 hours in advance of beginning work. Construction operations shall be conducted in a manner such that streets shall be open to emergency traffic and accessible as required to local traffic. Advanced notice shall be provided to residents, police, fire, school districts, school bus companies, and trash haulers when access to any street will be temporarily closed or limited. Removal and replacement of curb and gutter and driveways shall be planned so as to cause a minimum of inconvenience to the abutting property owners. The work shall be accomplished such that the streets shall be left open to local traffic at the end of each workday.

Method of Measurement. This work will be measured for payment on a lump sum basis. No measurement will be made of any of the individual components of this work.

Basis of Payment. Traffic control and protection will be paid for at the contract lump sum price for TRAFFIC CONTROL AND PROTECTION, which price shall include all of the above listed requirements, details, standards, and special provisions.

ITEM #65: CONTINGENCY ALLOWANCE

Description. A contingency allowance item is provided as a part of this contract for the purpose of facilitating the completion of unforeseen or additional work not included in the contract as awarded, and which is determined by the Engineer to be necessary and germane to the contract.

Use of the contingency allowance will be at the discretion of the Engineer. The Engineer may, at his/her discretion, use the contingency allowance for any of the following reasons:

- (a) Facilitate a temporary payment allowance to the Contractor for work completed under existing contract items and for which completed quantities exceed contract quantities;
- (b) Facilitate a temporary payment allowance to the Contractor for work completed beyond the scope of existing contract items; or
- (c) Facilitate a temporary payment allowance to the Contractor for the purchase of equipment, materials or such other requisition as Engineer determines to be necessary for the completion of the Work.

Such use of the CONTINGENCY ALLOWANCE will be further subject to approval by Owner. Owner's decision with regard to use of the CONTINGENCY ALLOWANCE will be final.

- A. Any payments made to Contractor under the CONTINGENCY ALLOWANCE will be considered temporary, and will only be retained by Contractor until such time that an authorization of contract changes can be approved and incorporated into the contract.
- B. Contractor, in accepting payments made under the CONTINGENCY ALLOWANCE, agrees to the terms of this and other applicable special provisions. Contractor agrees to relinquish any monies and any claim to monies paid under the CONTINGENCY ALLOWANCE upon approval of an authorization of contract changes and payment for any work for which payment was previously made under the CONTINGENCY ALLOWANCE. Contractor further agrees to return any monies previously paid thereunder.
- C. The CONTINGENCY ALLOWANCE ITEM for this contract has been established with a unit of measurement in dollars, a quantity of 30,000.00, and a contract unit price of one dollar (\$1.00), for a total CONTINGENCY ALLOWANCE contract price of thirty thousand dollars and no cents (\$30,000.00). Bidder, in submitting a bid, accepts the quantity, unit price, and total contract price of the CONTINGENCY ALLOWANCE.

**CENTRAL BOULEVARD IMPROVEMENTS
VILLAGE OF VILLA PARK**

Basis of Payment. This work will be paid for at the contract unit price per dollar for CONTINGENCY ALLOWANCE. The total bid amount for this item will be \$30,000.00.

NOT FOR BID

CENTRAL BOULEVARD IMPROVEMENTS
VILLAGE OF VILLA PARK

APPENDIX 1

INDEX FOR SUPPLEMENTAL AND RECURRING SPECIAL PROVISIONS
CHECK SHEET FOR RECURRING SPECIAL PROVISIONS
CHECK SHEET FOR LOCAL & STREETS RECURRING SPECIAL PROVISIONS
BDE SPECIAL PROVISIONS
LOCAL ROADS SPECIAL PROVISION FOR INSURANCE
DUPAGE COUNTY PREVAILING WAGES

NOT FOR BID

NOT FOR BID

INDEX
FOR
SUPPLEMENTAL SPECIFICATIONS
AND RECURRING SPECIAL PROVISIONS

Adopted January 1, 2017

This index contains a listing of SUPPLEMENTAL SPECIFICATIONS, frequently used RECURRING SPECIAL PROVISIONS, and LOCAL ROADS AND STREETS RECURRING SPECIAL PROVISIONS.

ERRATA Standard Specifications for Road and Bridge Construction
(Adopted 4-1-16) (Revised 1-1-17)

SUPPLEMENTAL SPECIFICATIONS

<u>Std. Spec. Sec.</u>		<u>Page No.</u>
106	Control of Materials	1
403	Bituminous Surface Treatment (Class A-1, A-2, A-3)	2
420	Portland Cement Concrete Pavement	3
502	Excavation for Structures	5
503	Concrete Structures	7
504	Precast Concrete Structures	10
542	Pipe Culverts	11
586	Sand Backfill for Vaulted Abutments	12
670	Engineer's Field Office and Laboratory	14
704	Temporary Concrete Barrier	15
888	Pedestrian Push-Button	17
1003	Fine Aggregates	18
1004	Coarse Aggregates	19
1006	Metals	21
1020	Portland Cement Concrete	22
1103	Portland Cement Concrete Equipment	24

NOT FOR BID



The Following Recurring Special Provisions Indicated By An "X" Are Applicable To This Contract And Are Included By Reference:

Recurring Special Provisions

<u>Check Sheet #</u>		<u>Page No.</u>
1	<input type="checkbox"/> Additional State Requirements for Federal-Aid Construction Contracts	26
2	<input type="checkbox"/> Subletting of Contracts (Federal-Aid Contracts)	29
3	<input type="checkbox"/> EEO	30
4	<input type="checkbox"/> Specific EEO Responsibilities Non Federal-Aid Contracts	40
5	<input type="checkbox"/> Required Provisions - State Contracts	45
6	<input type="checkbox"/> Asbestos Bearing Pad Removal	51
7	<input type="checkbox"/> Asbestos Waterproofing Membrane and Asbestos Hot-Mix Asphalt Surface Removal	52
8	<input type="checkbox"/> Temporary Stream Crossings and In-Stream Work Pads	53
9	<input type="checkbox"/> Construction Layout Stakes Except for Bridges	54
10	<input checked="" type="checkbox"/> Construction Layout Stakes	57
11	<input type="checkbox"/> Use of Geotextile Fabric for Railroad Crossing	60
12	<input type="checkbox"/> Subsealing of Concrete Pavements	62
13	<input type="checkbox"/> Hot-Mix Asphalt Surface Correction	66
14	<input type="checkbox"/> Pavement and Shoulder Resurfacing	68
15	<input type="checkbox"/> Patching with Hot-Mix Asphalt Overlay Removal	69
16	<input type="checkbox"/> Polymer Concrete	70
17	<input type="checkbox"/> PVC Pipeliner	72
18	<input type="checkbox"/> Bicycle Racks	73
19	<input type="checkbox"/> Temporary Portable Bridge Traffic Signals	75
20	<input type="checkbox"/> Work Zone Public Information Signs	77
21	<input type="checkbox"/> Nighttime Inspection of Roadway Lighting	78
22	<input type="checkbox"/> English Substitution of Metric Bolts	79
23	<input type="checkbox"/> Calcium Chloride Accelerator for Portland Cement Concrete	80
24	<input type="checkbox"/> Quality Control of Concrete Mixtures at the Plant	81
25	<input checked="" type="checkbox"/> Quality Control/Quality Assurance of Concrete Mixtures	89
26	<input type="checkbox"/> Digital Terrain Modeling for Earthwork Calculations	105
27	<input type="checkbox"/> Reserved	107
28	<input type="checkbox"/> Preventive Maintenance - Bituminous Surface Treatment	108
29	<input type="checkbox"/> Preventive Maintenance - Cape Seal	114
30	<input type="checkbox"/> Preventive Maintenance - Micro-Surfacing	129
31	<input type="checkbox"/> Preventive Maintenance - Slurry Seal	140
32	<input type="checkbox"/> Temporary Raised Pavement Markers	149
33	<input type="checkbox"/> Restoring Bridge Approach Pavements Using High-Density Foam	150
34	<input type="checkbox"/> Portland Cement Concrete Inlay or Overlay	153

NOT FOR BID

The Following Local Roads And Streets Recurring Special Provisions Indicated By An "X" Are Applicable To This Contract And Are Included By Reference:

Local Roads And Streets Recurring Special Provisions

<u>Check Sheet #</u>		<u>Page No.</u>
LRS 1	Reserved	158
LRS 2	<input type="checkbox"/> Furnished Excavation	159
LRS 3	<input checked="" type="checkbox"/> Work Zone Traffic Control Surveillance	160
LRS 4	<input checked="" type="checkbox"/> Flaggers in Work Zones	161
LRS 5	<input checked="" type="checkbox"/> Contract Claims	162
LRS 6	<input checked="" type="checkbox"/> Bidding Requirements and Conditions for Contract Proposals	163
LRS 7	<input type="checkbox"/> Bidding Requirements and Conditions for Material Proposals	169
LRS 8	Reserved	175
LRS 9	<input type="checkbox"/> Bituminous Surface Treatments	176
LRS 10	Reserved	177
LRS 11	<input checked="" type="checkbox"/> Employment Practices	178
LRS 12	<input checked="" type="checkbox"/> Wages of Employees on Public Works	180
LRS 13	<input checked="" type="checkbox"/> Selection of Labor	182
LRS 14	<input type="checkbox"/> Paving Brick and Concrete Paver Pavements and Sidewalks	183
LRS 15	<input checked="" type="checkbox"/> Partial Payments	186
LRS 16	<input checked="" type="checkbox"/> Protests on Local Lettings	187
LRS 17	<input checked="" type="checkbox"/> Substance Abuse Prevention Program	188
LRS 18	<input type="checkbox"/> Multigrade Cold Mix Asphalt	189

NOT FOR BID

BDE SPECIAL PROVISIONS
For the January 20 and March 10, 2017 Lettings

The following special provisions indicated by an "x" are applicable to this contract and will be included by the Project Development and Implementation Section of the BD&E. An * indicates a new or revised special provision for the letting.

<u>File Name</u>	<u>#</u>	<u>Special Provision Title</u>	<u>Effective</u>	<u>Revised</u>
80099	1	Accessible Pedestrian Signals (APS)	April 1, 2003	Jan. 1, 2014
80274	2	Aggregate Subgrade Improvement	April 1, 2012	April 1, 2016
80192	3	Automated Flagger Assistance Device	Jan. 1, 2008	
80173	4	Bituminous Materials Cost Adjustments	Nov. 2, 2006	July 1, 2015
80241	5	Bridge Demolition Debris	July 1, 2009	
5026I	6	Building Removal-Case I (Non-Friable and Friable Asbestos)	Sept. 1, 1990	April 1, 2010
5048I	7	Building Removal-Case II (Non-Friable Asbestos)	Sept. 1, 1990	April 1, 2010
5049I	8	Building Removal-Case III (Friable Asbestos)	Sept. 1, 1990	April 1, 2010
5053I	9	Building Removal-Case IV (No Asbestos)	Sept. 1, 1990	April 1, 2010
80366	10	Butt Joints	July 1, 2016	
80198	11	Completion Date (via calendar days)	April 1, 2008	
80199	12	Completion Date (via calendar days) Plus Working Days	April 1, 2008	
80293	13	Concrete Box Culverts with Skews > 30 Degrees and Design Fills ≤ 5 Feet	April 1, 2012	July 1, 2016
80311	14	Concrete End Sections for Pipe Culverts	Jan. 1, 2013	April 1, 2016
80277	15	Concrete Mix Design – Department Provided	Jan. 1, 2012	April 1, 2016
80261	16	Construction Air Quality – Diesel Retrofit	June 1, 2010	Nov. 1, 2014
80029	17	Disadvantaged Business Enterprise Participation	Sept. 1, 2000	July 2, 2016
* 80378	18	Dowel Bar Inserter	Jan. 1, 2017	
80229	19	Fuel Cost Adjustment	April 1, 2009	July 1, 2015
80304	20	Grooving for Recessed Pavement Markings	Nov. 1, 2012	Aug. 1, 2014
80246	21	Hot-Mix Asphalt – Density Testing of Longitudinal Joints	Jan. 1, 2010	April 1, 2016
80347	22	Hot-Mix Asphalt – Pay for Performance Using Percent Within Limits – Jobsite Sampling	Nov. 1, 2014	April 1, 2016
80376	23	Hot-Mix Asphalt – Tack Coat	Nov. 1, 2016	
80367	24	Light Poles	July 1, 2016	
80368	25	Light Tower	July 1, 2016	
80336	26	Longitudinal Joint and Crack Patching	April 1, 2014	April 1, 2016
80369	27	Mast Arm Assembly and Pole	July 1, 2016	
80045	28	Material Transfer Device	June 15, 1999	Aug. 1, 2014
80165	29	Moisture Cured Urethane Paint System	Nov. 1, 2006	Jan. 1, 2010
80349	30	Pavement Marking Blackout Tape	Nov. 1, 2014	April 1, 2016
80371	31	Pavement Marking Removal	July 1, 2016	
80298	32	Pavement Marking Tape Type IV	April 1, 2012	April 1, 2016
80377	33	Portable Changeable Message Signs	Nov. 1, 2016	
* 80359	34	Portland Cement Concrete Bridge Deck Curing	April 1, 2015	Jan. 1, 2017
80338	35	Portland Cement Concrete Partial Depth Hot-Mix Asphalt Patching	April 1, 2014	April 1, 2016
80300	36	Preformed Plastic Pavement Marking Type D - Inlaid	April 1, 2012	April 1, 2016
80328	37	Progress Payments	Nov. 2, 2013	
3426I	38	Railroad Protective Liability Insurance	Dec. 1, 1986	Jan. 1, 2006
80157	39	Railroad Protective Liability Insurance (5 and 10)	Jan. 1, 2006	
80306	40	Reclaimed Asphalt Pavement (RAP) and Reclaimed Asphalt Shingles (RAS)	Nov. 1, 2012	April 1, 2016
* 80340	41	Speed Display Trailer	April 2, 2014	Jan. 1, 2017
80127	42	Steel Cost Adjustment	April 2, 2004	July 1, 2015
* 80379	43	Steel Plate Beam Guardrail	Jan. 1, 2017	

NOT FOR BID

<u>File Name</u>	<u>#</u>	<u>Special Provision Title</u>	<u>Effective</u>	<u>Revised</u>
80317	44	Surface Testing of Hot-Mix Asphalt Overlays	Jan. 1, 2013	April 1, 2016
20338	45	Training Special Provisions	Oct. 15, 1975	
80318	46	Traversable Pipe Grate	Jan. 1, 2013	April 1, 2014
* 80381	47	Traffic Barrier Terminal, Type 1 Special	Jan. 1, 2017	
* 80380	48	Tubular Markers	Jan. 1, 2017	
80288	49	Warm Mix Asphalt	Jan. 1, 2012	April 1, 2016
80302	50	Weekly DBE Trucking Reports	June 2, 2012	April 2, 2015
80289	51	Wet Reflective Thermoplastic Pavement Marking	Jan. 1, 2012	
80071	52	Working Days	Jan. 1, 2002	

The following special provisions are in the 2017 Supplemental Specifications and Recurring Special Provisions.

<u>File Name</u>	<u>Special Provision Title</u>	<u>New Location</u>	<u>Effective</u>	<u>Revised</u>
80360	Coarse Aggregate Quality	Article 1004.01	July 1, 2015	
80363	Engineer's Field Office	Article 670.07	April 1, 2016	
80358	Equal Employment Opportunity	Recurring CS #1 and #5	April 1, 2015	
80364	Errata for the 2016 Standard Specifications	Supplemental	April 1, 2016	
80342	Mechanical Side Tie Bar Inserter	Articles 420.03, 420.05, and 1103.19	Aug. 1, 2014	April 1, 2016
80370	Mechanical Splicers	Article 1006.10	July 1, 2016	
80361	Overhead Sign Structures Certification of Metal Fabricator	Article 106.08	Nov. 1, 2015	April 1, 2016
80365	Pedestrian Push-Button	Article 888.03	April 1, 2016	
80353	Portland Cement Concrete Inlay or Overlay	Recurring CS #34	Jan. 1, 2015	April 1, 2016
80372	Preventive Maintenance – Bituminous Surface Treatment (A-1)	Recurring CS #28	Jan. 1, 2009	July 1, 2016
80373	Preventive Maintenance – Cape Seal	Recurring CS #29	Jan. 1, 2009	July 1, 2016
80374	Preventive Maintenance – Micro-Surfacing	Recurring CS #30	Jan. 1, 2009	July 1, 2016
80375	Preventive Maintenance – Slurry Seal	Recurring CS #31	Jan. 1, 2009	July 1, 2016
80362	Steel Slag in Trench Backfill	Articles 1003.01 and 1003.04	Jan. 1, 2016	
80355	Temporary Concrete Barrier	Articles 704.02, 704.04, 704.05, and 704.06	Jan. 1, 2015	July 1, 2015

The following special provisions require additional information from the designer. The additional information needs to be included in a separate document attached to this check sheet. The Project Development and Implementation section will then include the information in the applicable special provision. The Special Provisions are:

- Bridge Demolition Debris
- Building Removal-Case I
- Building Removal-Case II
- Building Removal-Case III
- Building Removal-Case IV
- Completion Date
- Completion Date Plus Working Days
- DBE Participation
- Material Transfer Device
- Railroad Protective Liability Insurance
- Training Special Provisions
- Working Days

NOT FOR BID

COMPLETION DATE (VIA CALENDAR DAYS) (BDE)

Effective: April 1, 2008

The Contractor shall complete all work on or before the completion date of this contract which will be based upon _____ calendar days.

The completion date will be determined by adding the specified number of calendar days to the date the Contractor begins work, or to the date ten days after execution of the contract, whichever is the earlier, unless a delayed start is granted by the Engineer.

80198

NOT FOR BIDD

NOT FOR BID

HOT-MIX ASPHALT - DENSITY TESTING OF LONGITUDINAL JOINTS (BDE)

Effective: January 1, 2010

Revised: April 1, 2016

Description. This work shall consist of testing the density of longitudinal joints as part of the quality control/quality assurance (QC/QA) of hot-mix asphalt (HMA). Work shall be according to Section 1030 of the Standard Specifications except as follows.

Quality Control/Quality Assurance (QC/QA). Delete the second and third sentence of the third paragraph of Article 1030.05(d)(3) of the Standard Specifications.

Add the following paragraphs to the end of Article 1030.05(d)(3) of the Standard Specifications:

“Longitudinal joint density testing shall be performed at each random density test location. Longitudinal joint testing shall be located at a distance equal to the lift thickness or a minimum of 4 in. (100 mm), from each pavement edge. (i.e. for a 5 in. (125 mm) lift the near edge of the density gauge or core barrel shall be within 5 in. (125 mm) from the edge of pavement.) Longitudinal joint density testing shall be performed using either a correlated nuclear gauge or cores.

- a. Confined Edge. Each confined edge density shall be represented by a one-minute nuclear density reading or a core density and shall be included in the average of density readings or core densities taken across the mat which represents the Individual Test.
- b. Unconfined Edge. Each unconfined edge joint density shall be represented by an average of three one-minute density readings or a single core density at the given density test location and shall meet the density requirements specified herein. The three one-minute readings shall be spaced 10 ft (3 m) apart longitudinally along the unconfined pavement edge and centered at the random density test location.”

Revise the Density Control Limits table in Article 1030.05(d)(4) of the Standard Specifications to read:

“Mixture Composition	Parameter	Individual Test (includes confined edges)	Unconfined Edge Joint Density Minimum
IL-4.75	Ndesign = 50	93.0 – 97.4% ^{1/}	91.0%
IL-9.5	Ndesign = 90	92.0 – 96.0%	90.0%
IL-9.5,IL-9.5L	Ndesign < 90	92.5 – 97.4%	90.0%
IL-19.0	Ndesign = 90	93.0 – 96.0%	90.0%
IL-19.0, IL-19.0L	Ndesign < 90	93.0 ^{2/} – 97.4%	90.0%
SMA	Ndesign = 50 & 80	93.5 – 97.4%	91.0%”

NOT FOR BID

CONSTRUCTION AIR QUALITY – DIESEL RETROFIT (BDE)

Effective: June 1, 2010

Revised: November 1, 2014

The reduction of emissions of particulate matter (PM) for off-road equipment shall be accomplished by installing retrofit emission control devices. The term “equipment” refers to diesel fuel powered devices rated at 50 hp and above, to be used on the jobsite in excess of seven calendar days over the course of the construction period on the jobsite (including rental equipment).

Contractor and subcontractor diesel powered off-road equipment assigned to the contract shall be retrofitted using the phased in approach shown below. Equipment that is of a model year older than the year given for that equipment’s respective horsepower range shall be retrofitted:

Effective Dates	Horsepower Range	Model Year
June 1, 2010 ^{1/}	600-749	2002
	750 and up	2006
June 1, 2011 ^{2/}	100-299	2003
	300-599	2001
	600-749	2002
	750 and up	2006
June 1, 2012 ^{2/}	50-99	2004
	100-299	2003
	300-599	2001
	600-749	2002
	750 and up	2006

1/ Effective dates apply to Contractor diesel powered off-road equipment assigned to the contract.

2/ Effective dates apply to Contractor and subcontractor diesel powered off-road equipment assigned to the contract.

The retrofit emission control devices shall achieve a minimum PM emission reduction of 50 percent and shall be:

- a) Included on the U.S. Environmental Protection Agency (USEPA) *Verified Retrofit Technology List* (<http://www.epa.gov/cleandiesel/verification/verif-list.htm>), or verified by the California Air Resources Board (CARB) (<http://www.arb.ca.gov/diesel/verdev/vt/cvt.htm>); or
- b) Retrofitted with a non-verified diesel retrofit emission control device if verified retrofit emission control devices are not available for equipment proposed to be used on the project, and if the Contractor has obtained a performance certification from the retrofit

device manufacturer that the emission control device provides a minimum PM emission reduction of 50 percent.

Note: Large cranes (Crawler mounted cranes) which are responsible for critical lift operations are exempt from installing retrofit emission control devices if such devices adversely affect equipment operation.

Diesel powered off-road equipment with engine ratings of 50 hp and above, which are unable to be retrofitted with verified emission control devices or if performance certifications are not available which will achieve a minimum 50 percent PM reduction, may be granted a waiver by the Department if documentation is provided showing good faith efforts were made by the Contractor to retrofit the equipment.

Construction shall not proceed until the Contractor submits a certified list of the diesel powered off-road equipment that will be used, and as necessary, retrofitted with emission control devices. The list(s) shall include (1) the equipment number, type, make, Contractor/rental company name; and (2) the emission control devices make, model, USEPA or CARB verification number, or performance certification from the retrofit device manufacturer. Equipment reported as fitted with emissions control devices shall be made available to the Engineer for visual inspection of the device installation, prior to being used on the jobsite.

The Contractor shall submit an updated list of retrofitted off-road construction equipment as retrofitted equipment changes or comes on to the jobsite. The addition or deletion of any diesel powered equipment shall be included on the updated list.

If any diesel powered off-road equipment is found to be in non-compliance with any portion of this special provision, the Engineer will issue the Contractor a diesel retrofit deficiency deduction.

Any costs associated with retrofitting any diesel powered off-road equipment with emission control devices shall be considered as included in the contract unit prices bid for the various items of work involved and no additional compensation will be allowed. The Contractor's compliance with this notice and any associated regulations shall not be grounds for a claim.

Diesel Retrofit Deficiency Deduction

When the Engineer determines that a diesel retrofit deficiency exists, a daily monetary deduction will be imposed for each calendar day or fraction thereof the deficiency continues to exist. The calendar day(s) will begin when the time period for correction is exceeded and end with the Engineer's written acceptance of the correction. The daily monetary deduction will be \$1,000.00 for each deficiency identified.

The deficiency will be based on lack of diesel retrofit emissions control.

If a Contractor accumulates three diesel retrofit deficiency deductions for the same piece of equipment in a contract period, the Contractor will be shutdown until the deficiency is corrected.

Such a shutdown will not be grounds for any extension of the contract time, waiver of penalties, or be grounds for any claim.

80261

NOT FOR BID

NOT FOR BID

RECLAIMED ASPHALT PAVEMENT AND RECLAIMED ASPHALT SHINGLES (BDE)

Effective: November 1, 2012

Revise: April 1, 2016

Revise Section 1031 of the Standard Specifications to read:

"SECTION 1031. RECLAIMED ASPHALT PAVEMENT AND RECLAIMED ASPHALT SHINGLES

1031.01 Description. Reclaimed asphalt pavement and reclaimed asphalt shingles shall be according to the following.

- (a) Reclaimed Asphalt Pavement (RAP). RAP is the material produced by cold milling or crushing an existing hot-mix asphalt (HMA) pavement. The Contractor shall supply written documentation that the RAP originated from routes or airfields under federal, state, or local agency jurisdiction.
- (b) Reclaimed Asphalt Shingles (RAS). Reclaimed asphalt shingles (RAS). RAS is from the processing and grinding of preconsumer or post-consumer shingles. RAS shall be a clean and uniform material with a maximum of 0.5 percent unacceptable material, as defined in Bureau of Materials and Physical Research Policy Memorandum, "Reclaimed Asphalt Shingle (RAS) Sources", by weight of RAS. All RAS used shall come from a Bureau of Materials and Physical Research approved processing facility where it shall be ground and processed to 100 percent passing the 3/8 in. (9.5 mm) sieve and 93 percent passing the #4 (4.75 mm) sieve based on a dry shake gradation. RAS shall be uniform in gradation and asphalt binder content and shall meet the testing requirements specified herein. In addition, RAS shall meet the following Type 1 or Type 2 requirements.
 - (1) Type 1. Type 1 RAS shall be processed, preconsumer asphalt shingles salvaged from the manufacture of residential asphalt roofing shingles.
 - (2) Type 2. Type 2 RAS shall be processed post-consumer shingles only, salvaged from residential, or four unit or less dwellings not subject to the National Emission Standards for Hazardous Air Pollutants (NESHAP).

1031.02 Stockpiles. RAP and RAS stockpiles shall be according to the following.

- (a) RAP Stockpiles. The Contractor shall construct individual, sealed RAP stockpiles meeting one of the following definitions. No additional RAP shall be added to the pile after the pile has been sealed. Stockpiles shall be sufficiently separated to prevent intermingling at the base. Stockpiles shall be identified by signs indicating the type as listed below (i.e. "Homogeneous Surface").

Prior to milling, the Contractor shall request the District provide documentation on the quality of the RAP to clarify the appropriate stockpile.

- (1) Fractionated RAP (FRAP). FRAP shall consist of RAP from Class I, HMA (High and Low ESAL) mixtures. The coarse aggregate in FRAP shall be crushed aggregate and may represent more than one aggregate type and/or quality, but shall be at least C quality. All FRAP shall be fractionated prior to testing by screening into a minimum of two size fractions with the separation occurring on or between the #4 (4.75 mm) and 1/2 in. (12.5 mm) sieves. Agglomerations shall be minimized such that 100 percent of the RAP shall pass the sieve size specified below for the mix into which the FRAP will be incorporated.

Mixture FRAP will be used in:	Sieve Size that 100 % of FRAP Shall Pass
IL-19.0	1 1/2 in. (40 mm)
IL-9.5	3/4 in. (20 mm)
IL-4.75	1/2 in. (13 mm)

- (2) Homogeneous. Homogeneous RAP stockpiles shall consist of RAP from Class I, HMA (High and Low ESAL) mixtures and represent: 1) the same aggregate quality, but shall be at least C quality; 2) the same type of crushed aggregate (either crushed natural aggregate, ACBF slag, or steel slag); 3) similar gradation; and 4) similar asphalt binder content. If approved by the Engineer, combined single pass surface/binder millings may be considered "homogeneous" with a quality rating dictated by the lowest coarse aggregate quality present in the mixture.
- (3) Conglomerate. Conglomerate RAP stockpiles shall consist of RAP from Class I, HMA (High and Low ESAL) mixtures. The coarse aggregate in this RAP shall be crushed aggregate and may represent more than one aggregate type and/or quality, but shall be at least C quality. This RAP may have an inconsistent gradation and/or asphalt binder content prior to processing. All conglomerate RAP shall be processed prior to testing by crushing to where all RAP shall pass the 5/8 in. (16 mm) or smaller screen. Conglomerate RAP stockpiles shall not contain steel slag.
- (4) Non-Quality. RAP stockpiles that do not meet the requirements of the stockpile categories listed above shall be classified as "Non-Quality".

RAP/FRAP containing contaminants, such as earth, brick, sand, concrete, sheet asphalt, bituminous surface treatment (i.e. chip seal), pavement fabric, joint sealants, etc., will be unacceptable unless the contaminants are removed to the satisfaction of the Engineer. Sheet asphalt shall be stockpiled separately.

- (b) RAS Stockpiles. Type 1 and Type 2 RAS shall be stockpiled separately and shall not be intermingled. Each stockpile shall be signed indicating what type of RAS is present.

Unless otherwise specified by the Engineer, mechanically blending manufactured sand (FM 20 or FM 22) up to an equal weight of RAS with the processed RAS will be permitted to improve workability. The sand shall be "B Quality" or better from an approved Aggregate Gradation Control System source. The sand shall be accounted for in the mix design and during HMA production.

Records identifying the shingle processing facility supplying the RAS, RAS type, and lot number shall be maintained by project contract number and kept for a minimum of three years.

1031.03 Testing. RAP/FRAP and RAS testing shall be according to the following.

(a) RAP/FRAP Testing. When used in HMA, the RAP/FRAP shall be sampled and tested either during or after stockpiling.

(1) During Stockpiling. For testing during stockpiling, washed extraction samples shall be run at the minimum frequency of one sample per 500 tons (450 metric tons) for the first 2000 tons (1800 metric tons) and one sample per 2000 tons (1800 metric tons) thereafter. A minimum of five tests shall be required for stockpiles less than 4000 tons (3600 metric tons).

(2) After Stockpiling. For testing after stockpiling, the Contractor shall submit a plan for approval to the District proposing a satisfactory method of sampling and testing the RAP/FRAP pile either in-situ or by restockpiling. The sampling plan shall meet the minimum frequency required above and detail the procedure used to obtain representative samples throughout the pile for testing.

Each sample shall be split to obtain two equal samples of test sample size. One of the two test samples from the final split shall be labeled and stored for Department use. The Contractor shall extract the other test sample according to Department procedure. The Engineer reserves the right to test any sample (split or Department-taken) to verify Contractor test results.

(b) RAS Testing. RAS or RAS blended with manufactured sand shall be sampled and tested during stockpiling according to Bureau of Materials and Physical Research Policy Memorandum, "Reclaimed Asphalt Shingle (RAS) Source".

Samples shall be collected during stockpiling at the minimum frequency of one sample per 200 tons (180 metric tons) for the first 1000 tons (900 metric tons) and one sample per 250 tons (225 metric tons) thereafter. A minimum of five samples are required for stockpiles less than 1000 tons (900 metric tons). Once a ≤ 1000 ton (900 metric ton), five-sample/test stockpile has been established it shall be sealed. Additional incoming RAS or RAS blended with manufactured sand shall be stockpiled in a separate working pile as designated in the Quality Control plan and only added to the sealed stockpile when the test results of the working pile are complete and are found to meet the tolerances specified herein for the original sealed RAS stockpile.

Before testing, each sample shall be split to obtain two test samples. One of the two test samples from the final split shall be labeled and stored for Department use. The Contractor shall perform a washed extraction and test for unacceptable materials on the other test sample according to Department procedures. The Engineer reserves the right to test any sample (split or Department-taken) to verify Contractor test results.

If the sampling and testing was performed at the shingle processing facility in accordance with the QC Plan, the Contractor shall obtain and make available all of the test results from start of the initial stockpile.

1031.04 Evaluation of Tests. Evaluation of test results shall be according to the following.

- (a) Evaluation of RAP/FRAP Test Results. All of the extraction results shall be compiled and averaged for asphalt binder content and gradation, and when applicable G_{mm} . Individual extraction test results, when compared to the averages, will be accepted if within the tolerances listed below.

Parameter	FRAP/Homogeneous/ Conglomerate
1 in. (25 mm)	
1/2 in. (12.5 mm)	± 8 %
No. 4 (4.75 mm)	± 6 %
No. 8 (2.36 mm)	± 5 %
No. 16 (1.18 mm)	
No. 30 (600 μm)	± 5 %
No. 200 (75 μm)	± 2.0 %
Asphalt Binder	± 0.4 % ^{1/}
G_{mm}	± 0.03

^{1/} The tolerance for FRAP shall be ± 0.3 %.

If more than 20 percent of the individual sieves and/or asphalt binder content tests are out of the above tolerances, the RAP/FRAP shall not be used in HMA unless the RAP/FRAP representing the failing tests is removed from the stockpile. All test data and acceptance ranges shall be sent to the District for evaluation.

With the approval of the Engineer, the ignition oven may be substituted for extractions according to the ITP, "Calibration of the Ignition Oven for the Purpose of Characterizing Reclaimed Asphalt Pavement (RAP)".

- (b) Evaluation of RAS and RAS Blended with Manufactured Sand Test Results. All of the test results, with the exception of percent unacceptable materials, shall be compiled and averaged for asphalt binder content and gradation. Individual test results, when compared to the averages, will be accepted if within the tolerances listed below.

Parameter	RAS
No. 8 (2.36 mm)	± 5 %
No. 16 (1.18 mm)	± 5 %
No. 30 (600 µm)	± 4 %
No. 200 (75 µm)	± 2.0 %
Asphalt Binder Content	± 1.5 %

If more than 20 percent of the individual sieves and/or asphalt binder content tests are out of the above tolerances, or if the percent unacceptable material exceeds 0.5 percent by weight of material retained on the # 4 (4.75 mm) sieve, the RAS or RAS blend shall not be used in Department projects. All test data and acceptance ranges shall be sent to the District for evaluation.

1031.05 Quality Designation of Aggregate in RAP/FRAP.

(a) RAP. The aggregate quality of the RAP for homogeneous and conglomerate stockpiles shall be set by the lowest quality of coarse aggregate in the RAP stockpile and are designated as follows.

(1) RAP from Class I, Superpave/HMA (High ESAL), or (Low ESAL) IL-9.5L surface mixtures are designated as containing Class B quality coarse aggregate.

(2) RAP from Class I binder, Superpave/HMA (High ESAL) binder, or (Low ESAL) IL-19.0L binder mixtures are designated as containing Class C quality coarse aggregate.

(b) FRAP. If the Engineer has documentation of the quality of the FRAP aggregate, the Contractor shall use the assigned quality provided by the Engineer.

If the quality is not known, the quality shall be determined as follows. Coarse and fine FRAP stockpiles containing plus #4 (4.75 mm) sieve coarse aggregate shall have a maximum tonnage of 5000 tons (4500 metric tons). The Contractor shall obtain a representative sample witnessed by the Engineer. The sample shall be a minimum of 50 lb (25 kg). The sample shall be extracted according to Illinois Modified AASHTO T 164 by a consultant laboratory prequalified by the Department for the specified testing. The consultant laboratory shall submit the test results along with the recovered aggregate to the District Office. The cost for this testing shall be paid by the Contractor. The District will forward the sample to the Bureau of Materials and Physical Research Aggregate Lab for MicroDeval Testing, according to ITP 327. A maximum loss of 15.0 percent will be applied for all HMA applications.

1031.06 Use of RAP/FRAP and/or RAS in HMA. The use of RAP/FRAP and/or RAS shall be the Contractor's option when constructing HMA in all contracts.

(a) RAP/FRAP. The use of RAP/FRAP in HMA shall be as follows.

- (1) Coarse Aggregate Size. The coarse aggregate in all RAP shall be equal to or less than the nominal maximum size requirement for the HMA mixture to be produced.
 - (2) Steel Slag Stockpiles. Homogeneous RAP stockpiles containing steel slag will be approved for use in all HMA (High ESAL and Low ESAL) Surface and Binder Mixture applications.
 - (3) Use in HMA Surface Mixtures (High and Low ESAL). RAP/FRAP stockpiles for use in HMA surface mixtures (High and Low ESAL) shall be FRAP or homogeneous in which the coarse aggregate is Class B quality or better. RAP/FRAP from Conglomerate stockpiles shall be considered equivalent to limestone for frictional considerations. Known frictional contributions from plus #4 (4.75 mm) homogeneous RAP and FRAP stockpiles will be accounted for in meeting frictional requirements in the specified mixture.
 - (4) Use in HMA Binder Mixtures (High and Low ESAL), HMA Base Course, and HMA Base Course Widening. RAP/FRAP stockpiles for use in HMA binder mixtures (High and Low ESAL), HMA base course, and HMA base course widening shall be FRAP, homogeneous, or conglomerate, in which the coarse aggregate is Class C quality or better.
 - (5) Use in Shoulders and Subbase. RAP/FRAP stockpiles for use in HMA shoulders and stabilized subbase (HMA) shall be FRAP, homogeneous, or conglomerate.
 - (6) When the Contractor chooses the RAP option, the percentage of RAP shall not exceed the amounts indicated in Article 1031.06(c)(1) below for a given Ndesign.
- (b) RAS. RAS meeting Type 1 or Type 2 requirements will be permitted in all HMA applications as specified herein.
- (c) RAP/FRAP and/or RAS Usage Limits. Type 1 or Type 2 RAS may be used alone or in conjunction with RAP or FRAP in HMA mixtures up to a maximum of 5.0 percent by weight of the total mix.
- (1) RAP/RAS. When RAP is used alone or RAP is used in conjunction with RAS, the percentage of virgin asphalt binder replacement shall not exceed the amounts listed in the Max RAP/RAS ABR table listed below for the given Ndesign.

RAP/RAS Maximum Asphalt Binder Replacement (ABR) Percentage

HMA Mixtures <i>1/, 2/</i>	RAP/RAS Maximum ABR %		
	Binder/Leveling Binder	Surface	Polymer Modified
30	30	30	10

50	25	15	10
70	15	10	10
90	10	10	10

1/ For Low ESAL HMA shoulder and stabilized subbase, the RAP/RAS ABR shall not exceed 50 percent of the mixture.

2/ When RAP/RAS ABR exceeds 20 percent, the high and low virgin asphalt binder grades shall each be reduced by one grade (i.e. 25 percent ABR would require a virgin asphalt binder grade of PG 64-22 to be reduced to a PG 58-28). If warm mix asphalt (WMA) technology is utilized and production temperatures do not exceed 275 °F (135 °C), the high and low virgin asphalt binder grades shall each be reduced by one grade when RAP/RAS ABR exceeds 25 percent (i.e. 26 percent RAP/RAS ABR would require a virgin asphalt binder grade of PG 64-22 to be reduced to a PG 58-28).

(2) FRAP/RAS. When FRAP is used alone or FRAP is used in conjunction with RAS, the percentage of virgin asphalt binder replacement shall not exceed the amounts listed in the FRAP/RAS table listed below for the given Ndesign.

FRAP/RAS Maximum Asphalt Binder Replacement (ABR) Percentage

HMA Mixtures <i>1, 2/</i>	FRAP/RAS Maximum ABR %		
	Ndesign	Binder/Leveling Binder	Surface
30	50	40	10
50	40	35	10
70	40	30	10
90	40	30	10

1/ For Low ESAL HMA shoulder and stabilized subbase, the FRAP/RAS ABR shall not exceed 50 percent of the mixture.

2/ When FRAP/RAS ABR exceeds 20 percent for all mixes, the high and low virgin asphalt binder grades shall each be reduced by one grade (i.e. 25 percent ABR would require a virgin asphalt binder grade of PG 64-22 to be reduced to a PG 58-28). If warm mix asphalt (WMA) technology is utilized and production temperatures do not exceed 275 °F (135 °C), the high and low virgin asphalt binder grades shall each be reduced by one grade when FRAP/RAS ABR exceeds 25 percent (i.e. 26 percent ABR would require a virgin asphalt binder grade of PG 64-22 to be reduced to a PG 58-28).

3/ For SMA the FRAP/RAS ABR shall not exceed 20 percent.

4/ For IL-4.75 mix the FRAP/RAS ABR shall not exceed 30 percent.

1031.07 HMA Mix Designs. At the Contractor's option, HMA mixtures may be constructed utilizing RAP/FRAP and/or RAS material meeting the detailed requirements specified herein.

- (a) RAP/FRAP and/or RAS. RAP/FRAP and/or RAS mix designs shall be submitted for verification. If additional RAP/FRAP and/or RAS stockpiles are tested and found that no more than 20 percent of the results, as defined under "Testing" herein, are outside of the control tolerances set for the original RAP/FRAP and/or RAS stockpile and HMA mix design, and meets all of the requirements herein, the additional RAP/FRAP and/or RAS stockpiles may be used in the original mix design at the percent previously verified.
- (b) RAS. Type 1 and Type 2 RAS are not interchangeable in a mix design. A RAS stone bulk specific gravity (Gsb) of 2.300 shall be used for mix design purposes.

1031.08 HMA Production. HMA production utilizing RAP/FRAP and/or RAS shall be as follows.

- (a) RAP/FRAP. The coarse aggregate in all RAP/FRAP used shall be equal to or less than the nominal maximum size requirement for the HMA mixture being produced.

To remove or reduce agglomerated material, a scalping screen, gator, crushing unit, or comparable sizing device approved by the Engineer shall be used in the RAP feed system to remove or reduce oversized material. If material passing the sizing device adversely affects the mix production or quality of the mix, the sizing device shall be set at a size specified by the Engineer.

If the RAP/FRAP control tolerances or QC/QA test results require corrective action, the Contractor shall cease production of the mixture containing RAP/FRAP and either switch to the virgin aggregate design or submit a new RAP/FRAP design.

- (b) RAS. RAS shall be incorporated into the HMA mixture either by a separate weight depletion system or by using the RAP weigh belt. Either feed system shall be interlocked with the aggregate feed or weigh system to maintain correct proportions for all rates of production and batch sizes. The portion of RAS shall be controlled accurately to within ± 0.5 percent of the amount of RAS utilized. When using the weight depletion system, flow indicators or sensing devices shall be provided and interlocked with the plant controls such that the mixture production is halted when RAS flow is interrupted.
- (c) RAP/FRAP and/or RAS. HMA plants utilizing RAP/FRAP and/or RAS shall be capable of automatically recording and printing the following information.

(1) Dryer Drum Plants.

- a. Date, month, year, and time to the nearest minute for each print.

- b. HMA mix number assigned by the Department.
- c. Accumulated weight of dry aggregate (combined or individual) in tons (metric tons) to the nearest 0.1 ton (0.1 metric ton).
- d. Accumulated dry weight of RAP/FRAP/RAS in tons (metric tons) to the nearest 0.1 ton (0.1 metric ton).
- e. Accumulated mineral filler in revolutions, tons (metric tons), etc. to the nearest 0.1 unit.
- f. Accumulated asphalt binder in gallons (liters), tons (metric tons), etc. to the nearest 0.1 unit.
- g. Residual asphalt binder in the RAP/FRAP material as a percent of the total mix to the nearest 0.1 percent.
- h. Aggregate and RAP/FRAP moisture compensators in percent as set on the control panel. (Required when accumulated or individual aggregate and RAP/FRAP are printed in wet condition.)

(2) Batch Plants.

- a. Date, month, year, and time to the nearest minute for each print.
- b. HMA mix number assigned by the Department.
- c. Individual virgin aggregate hot bin batch weights to the nearest pound (kilogram).
- d. Mineral filler weight to the nearest pound (kilogram).
- e. RAP/FRAP/RAS weight to the nearest pound (kilogram).
- f. Virgin asphalt binder weight to the nearest pound (kilogram).
- g. Residual asphalt binder in the RAP/FRAP/RAS material as a percent of the total mix to the nearest 0.1 percent.

The printouts shall be maintained in a file at the plant for a minimum of one year or as directed by the Engineer and shall be made available upon request. The printing system will be inspected by the Engineer prior to production and verified at the beginning of each construction season thereafter.

1031.09 RAP in Aggregate Surface Course and Aggregate Wedge Shoulders, Type B.

The use of RAP in aggregate surface course (temporary access entrances only) and aggregate wedge shoulders, Type B shall be as follows.

- (a) Stockpiles and Testing. RAP stockpiles may be any of those listed in Article 1031.02, except "Non-Quality" and "FRAP". The testing requirements of Article 1031.03 shall not apply. RAP used shall be according to the current Bureau of Materials and Physical Research Policy Memorandum, "Reclaimed Asphalt Pavement (RAP) for Aggregate Applications".
- (b) Gradation. One hundred percent of the RAP material shall pass the 1 1/2 in. (37.5 mm) sieve. The RAP material shall be reasonably well graded from coarse to fine. RAP material that is gap-graded or single sized will not be accepted."

80306

PROGRESS PAYMENTS (BDE)

Effective: November 2, 2013

Revise Article 109.07(a) of the Standard Specifications to read:

“(a) Progress Payments. At least once each month, the Engineer will make a written estimate of the quantity of work performed in accordance with the contract, and the value thereof at the contract unit prices. The amount of the estimate approved as due for payment will be vouchered by the Department and presented to the State Comptroller for payment. No amount less than \$1000.00 will be approved for payment other than the final payment.

Progress payments may be reduced by liens filed pursuant to Section 23(c) of the Mechanics' Lien Act, 770 ILCS 60/23(c).

If a Contractor or subcontractor has defaulted on a loan issued under the Department's Disadvantaged Business Revolving Loan Program (20 ILCS 2705/2705-610), progress payments may be reduced pursuant to the terms of that loan agreement. In such cases, the amount of the estimate related to the work performed by the Contractor or subcontractor, in default of the loan agreement, will be offset, in whole or in part, and vouchered by the Department to the Working Capital Revolving Fund or designated escrow account. Payment for the work shall be considered as issued and received by the Contractor or subcontractor on the date of the offset voucher. Further, the amount of the offset voucher shall be a credit against the Department's obligation to pay the Contractor, the Contractor's obligation to pay the subcontractor, and the Contractor's or subcontractor's total loan indebtedness to the Department. The offset shall continue until such time as the entire loan indebtedness is satisfied. The Department will notify the Contractor and Fund Control Agent in a timely manner of such offset. The Contractor or subcontractor shall not be entitled to additional payment in consideration of the offset.

The failure to perform any requirement, obligation, or term of the contract by the Contractor shall be reason for withholding any progress payments until the Department determines that compliance has been achieved.”

NOT FOR BID

State of Illinois
Department of Transportation
Bureau of Local Roads and Streets

SPECIAL PROVISION
FOR
INSURANCE

Effective: February 1, 2007
Revised: August 1, 2007

All references to Sections or Articles in this specification shall be construed to mean specific Section or Article of the Standard Specifications for Road and Bridge Construction, adopted by the Department of Transportation.

The Contractor shall name the following entities as additional insured under the Contractor's general liability insurance policy in accordance with Article 107.27:

Village of Villa Park

RJN Group, Inc.

Hancock Engineering

Village's Consultants

County of DuPage

The entities listed above and their officers, employees, and agents shall be indemnified and held harmless in accordance with Article 107.26.

NOT FOR BID

**CENTRAL BOULEVARD IMPROVEMENTS
VILLAGE OF VILLA PARK**

Illinois Department of Labor

Division of Conciliation and Mediation

Dupage County Prevailing Wage for July, 2015

NOT FOR BID

NOT FOR BID

CENTRAL BOULEVARD IMPROVEMENTS VILLAGE OF VILLA PARK

(See explanation of column headings at bottom of wages)

Trade Name	RG	TYP	C	Base	FRMAN	M-F>8	OSA	OSH	H/W	Pensn	Vac	Trng	
ASBESTOS ABT-GEN	ALL			39.400	39.950	1.5	1.5	2.0	13.98	10.72	0.000	0.500	
ASBESTOS ABT-MEC	BLD			36.340	38.840	1.5	1.5	2.0	11.47	10.96	0.000	0.720	
BOILERMAKER	BLD			47.070	51.300	2.0	2.0	2.0	6.970	18.13	0.000	0.400	
BRICK MASON	BLD			43.780	48.160	1.5	1.5	2.0	10.05	14.43	0.000	1.030	
CARPENTER	ALL			44.350	46.350	1.5	1.5	2.0	11.79	16.39	0.000	0.630	
CEMENT MASON	ALL			43.750	45.750	2.0	1.5	2.0	13.05	14.45	0.000	0.480	
CERAMIC TILE FNSHER	BLD			36.810	0.000	1.5	1.5	2.0	10.55	9.230	0.000	0.770	
COMMUNICATION TECH	BLD			32.650	34.750	1.5	1.5	2.0	9.550	15.16	1.250	0.610	
ELECTRIC PWR EQMT OP	ALL			37.890	51.480	1.5	1.5	2.0	5.000	11.75	0.000	0.380	
ELECTRIC PWR EQMT OP	HWY			39.220	53.290	1.5	1.5	2.0	5.000	12.17	0.000	0.390	
ELECTRIC PWR GRNDMAN	ALL			29.300	51.480	1.5	1.5	2.0	5.000	9.090	0.000	0.290	
ELECTRIC PWR GRNDMAN	HWY			30.330	53.290	1.5	1.5	2.0	5.000	9.400	0.000	0.300	
ELECTRIC PWR LINEMAN	ALL			45.360	51.480	1.5	1.5	2.0	5.000	14.06	0.000	0.450	
ELECTRIC PWR LINEMAN	HWY			46.950	53.290	1.5	1.5	2.0	5.000	14.56	0.000	0.470	
ELECTRIC PWR TRK DRV	ALL			30.340	51.480	1.5	1.5	2.0	5.000	9.400	0.000	0.300	
ELECTRIC PWR TRK DRV	HWY			31.400	53.290	1.5	1.5	2.0	5.000	9.730	0.000	0.310	
ELECTRICIAN	BLD			38.160	41.980	1.5	1.5	2.0	9.550	18.29	4.680	0.680	
ELEVATOR CONSTRUCTOR	BLD			50.800	57.150	2.0	2.0	2.0	13.57	14.21	4.060	0.600	
FENCE ERECTOR	NE ALL			37.340	39.340	1.5	1.5	2.0	13.05	12.06	0.000	0.300	
FENCE ERECTOR	W ALL			45.060	48.660	2.0	2.0	2.0	10.52	20.76	0.000	0.700	
GLAZIER	BLD			40.500	42.000	1.5	2.0	2.0	13.14	16.99	0.000	0.940	
HT/FROST INSULATOR	BLD			48.450	50.950	1.5	1.5	2.0	11.47	12.16	0.000	0.720	
IRON WORKER	E ALL			44.200	46.200	2.0	2.0	2.0	13.65	21.14	0.000	0.350	
IRON WORKER	W ALL			45.060	48.660	2.0	2.0	2.0	10.52	20.76	0.000	0.700	
LABORER	ALL			39.200	39.950	1.5	1.5	2.0	13.98	10.72	0.000	0.500	
LATHER	ALL			44.350	46.350	1.5	1.5	2.0	11.79	16.39	0.000	0.630	
MACHINIST	BLD			45.350	47.850	1.5	1.5	2.0	7.260	8.950	1.850	0.000	
MARBLE FINISHERS	ALL			32.400	34.320	1.5	1.5	2.0	10.05	13.75	0.000	0.620	
MARBLE MASON	BLD			43.030	47.330	1.5	1.5	2.0	10.05	14.10	0.000	0.780	
MATERIAL TESTER I	ALL			29.200	0.000	1.5	1.5	2.0	13.98	10.72	0.000	0.500	
MATERIALS TESTER II	ALL			34.200	0.000	1.5	1.5	2.0	13.98	10.72	0.000	0.500	
MILLWRIGHT	ALL			44.350	46.350	1.5	1.5	2.0	11.79	16.39	0.000	0.630	
OPERATING ENGINEER	BLD 1			48.100	52.100	2.0	2.0	2.0	17.55	12.65	1.900	1.250	
OPERATING ENGINEER	BLD 2			46.800	52.100	2.0	2.0	2.0	17.55	12.65	1.900	1.250	
OPERATING ENGINEER	BLD 3			44.250	52.100	2.0	2.0	2.0	17.55	12.65	1.900	1.250	
OPERATING ENGINEER	BLD 4			42.500	52.100	2.0	2.0	2.0	17.55	12.65	1.900	1.250	
OPERATING ENGINEER	BLD 5			51.850	52.100	2.0	2.0	2.0	17.55	12.65	1.900	1.250	
OPERATING ENGINEER	BLD 6			49.100	52.100	2.0	2.0	2.0	17.55	12.65	1.900	1.250	
OPERATING ENGINEER	BLD 7			51.100	52.100	2.0	2.0	2.0	17.55	12.65	1.900	1.250	
OPERATING ENGINEER	FLT			36.000	36.000	1.5	1.5	2.0	17.10	11.80	1.900	1.250	
OPERATING ENGINEER	HWY 1			46.300	50.300	1.5	1.5	2.0	17.55	12.65	1.900	1.250	
OPERATING ENGINEER	HWY 2			45.750	50.300	1.5	1.5	2.0	17.55	12.65	1.900	1.250	
OPERATING ENGINEER	HWY 3			43.700	50.300	1.5	1.5	2.0	17.55	12.65	1.900	1.250	
OPERATING ENGINEER	HWY 4			42.300	50.300	1.5	1.5	2.0	17.55	12.65	1.900	1.250	
OPERATING ENGINEER	HWY 5			41.100	50.300	1.5	1.5	2.0	17.55	12.65	1.900	1.250	
OPERATING ENGINEER	HWY 6			49.300	50.300	1.5	1.5	2.0	17.55	12.65	1.900	1.250	
OPERATING ENGINEER	HWY 7			47.300	50.300	1.5	1.5	2.0	17.55	12.65	1.900	1.250	
ORNAMNTL IRON WORKER	E ALL			45.000	47.500	2.0	2.0	2.0	13.55	17.94	0.000	0.650	
ORNAMNTL IRON WORKER	W ALL			45.060	48.660	2.0	2.0	2.0	10.52	20.76	0.000	0.700	
PAINTER	ALL			41.730	43.730	1.5	1.5	1.5	10.30	8.200	0.000	1.350	
PAINTER SIGNS	BLD			33.920	38.090	1.5	1.5	1.5	2.600	2.710	0.000	0.000	
PILEDRIIVER	ALL			44.350	46.350	1.5	1.5	2.0	11.79	16.39	0.000	0.630	
PIPEFITTER	BLD			46.000	49.000	1.5	1.5	2.0	9.000	15.85	0.000	1.780	
PLASTERER	BLD			43.430	46.040	1.5	1.5	2.0	10.05	14.43	0.000	1.020	
PLUMBER	BLD			46.650	48.650	1.5	1.5	2.0	13.18	11.46	0.000	0.880	
ROOFER	BLD			41.000	44.000	1.5	1.5	2.0	8.280	10.54	0.000	0.530	
SHEETMETAL WORKER	BLD			44.720	46.720	1.5	1.5	2.0	10.65	13.31	0.000	0.820	
SPRINKLER FITTER	BLD			49.200	51.200	1.5	1.5	2.0	11.75	9.650	0.000	0.550	
STEEL ERECTOR	E ALL			42.070	44.070	2.0	2.0	2.0	13.45	19.59	0.000	0.350	
STEEL ERECTOR	W ALL			45.060	48.660	2.0	2.0	2.0	10.52	20.76	0.000	0.700	
STONE MASON	BLD			43.780	48.160	1.5	1.5	2.0	10.05	14.43	0.000	1.030	
SURVEY WORKER													
-->NOT IN EFFECT				ALL	37.000	37.750	1.5	1.5	2.0	12.97	9.930	0.000	0.500

**CENTRAL BOULEVARD IMPROVEMENTS
VILLAGE OF VILLA PARK**

TERRAZZO FINISHER	BLD	38.040	0.000	1.5	1.5	2.0	10.55	11.22	0.000	0.720
TERRAZZO MASON	BLD	41.880	44.880	1.5	1.5	2.0	10.55	12.51	0.000	0.940
ILE MASON	BLD	43.840	47.840	1.5	1.5	2.0	10.55	11.40	0.000	0.990
TRAFFIC SAFETY WRKR	HWY	32.750	34.350	1.5	1.5	2.0	6.550	6.450	0.000	0.500
TRUCK DRIVER	ALL 1	35.920	36.120	1.5	1.5	2.0	8.280	8.760	0.000	0.150
TRUCK DRIVER	ALL 2	32.700	33.100	1.5	1.5	2.0	6.500	4.350	0.000	0.150
TRUCK DRIVER	ALL 3	32.900	33.100	1.5	1.5	2.0	6.500	4.350	0.000	0.150
TRUCK DRIVER	ALL 4	33.100	33.100	1.5	1.5	2.0	6.500	4.350	0.000	0.150
TUCKPOINTER	BLD	42.620	43.620	1.5	1.5	2.0	10.05	13.34	0.000	0.670

Legend: RG (Region)
 TYP (Trade Type - All, Highway, Building, Floating, Oil & Chip, Rivers)
 C (Class)
 Base (Base Wage Rate) FRMAN (Foreman Rate)
 M-F>8 (OT required for any hour greater than 8 worked each day, Mon through Fri.)
 OSA (Overtime (OT) is required for every hour worked on Saturday)
 OSH (Overtime is required for every hour worked on Sunday and Holidays)
 H/W (Health & Welfare Insurance)
 Pensn (Pension)
 Vac (Vacation)
 Trng (Training)

Explanations

DUPAGE COUNTY

IRON WORKERS AND FENCE ERECTOR (WEST) - West of Route 53.

The following list is considered as those days for which holiday rates of wages for work performed apply: New Year's Day, Memorial Day, Fourth of July, Labor Day, Thanksgiving Day, Christmas Day and Veterans Day in some classifications/counties. Generally, any of these holidays which fall on a Sunday is celebrated on the following Monday. This then makes work performed on that Monday payable at the appropriate overtime rate for holiday pay. Common practice in a given local may alter certain days of celebration. If in doubt, please check with IDOL.

EXPLANATION OF CLASSES

ASBESTOS - GENERAL - removal of asbestos material/mold and hazardous materials from any place in a building, including mechanical systems where those mechanical systems are to be removed. This includes the removal of asbestos materials/mold and hazardous materials from ductwork or pipes in a building when the building is to be demolished at the time or at some close future date.

ASBESTOS - MECHANICAL - removal of asbestos material from mechanical systems, such as pipes, ducts, and boilers, where the mechanical systems are to remain.

TRAFFIC SAFETY - work associated with barricades, horses and drums used to reduce lane usage on highway work, the installation and removal of temporary lane markings, and the installation and removal of temporary road signs.

CERAMIC TILE FINISHER

The grouting, cleaning, and polishing of all classes of tile, whether for interior or exterior purposes, all burned, glazed or unglazed products; all composition materials, granite tiles, warning detectable tiles, cement tiles, epoxy composite materials, pavers, glass, mosaics, fiberglass, and all substitute materials, for tile made in tile-like units; all mixtures in tile like form of cement, metals, and other materials that are for and intended for use as a finished floor surface, stair treads, promenade roofs, walks, walls, ceilings, swimming pools, and all other places where tile is to form a finished interior or exterior. The mixing of all setting mortars including but not limited to thin-set mortars, epoxies, wall mud, and any other sand and cement mixtures or adhesives when used in the preparation, installation, repair, or maintenance of tile and/or similar materials. The handling and unloading of all sand, cement, lime, tile, fixtures, equipment, adhesives, or any other materials to be used in the preparation, installation, repair, or maintenance of tile and/or similar materials. Ceramic Tile Finishers shall fill all joints and voids regardless of method on all tile work, particularly and especially after installation of said tile work. Application of any and all protective coverings to all types of tile installations including, but not be limited to, all soap compounds, paper products, tapes, and all polyethylene coverings, plywood, masonite, cardboard, and any new type of products that may be used to protect tile installations, Blastrac equipment, and all floor scariying equipment used in preparing floors to receive tile. The clean-up and removal of all waste and materials. All demolition of existing tile floors and walls to be re-tiled.

COMMUNICATIONS TECHNICIAN

Low voltage installation, maintenance and removal of telecommunication facilities (voice, sound, data and video) including telephone and data inside wire, interconnect, terminal equipment, central offices, PABX, fiber optic cable and equipment, micro waves, V-SAT, bypass, CATV, WAN (wide area networks), LAN (local area networks), and ISDN (integrated system digital network), pulling of wire in raceways, but not the installation of raceways.

CENTRAL BOULEVARD IMPROVEMENTS VILLAGE OF VILLA PARK

MARBLE FINISHER

Loading and unloading trucks, distribution of all materials (all stone, sand, etc.), stocking of floors with material, performing all rigging for heavy work, the handling of all material that may be needed for the installation of such materials, building of scaffolding, polishing if needed, patching, waxing of material if damaged, pointing up, caulking, grouting and cleaning of marble, holding water on diamond or Carborundum blade or saw for setters cutting, use of tub saw or any other saw needed for preparation of material, drilling of holes for wires that anchor material set by setters, mixing up of molding plaster for installation of material, mixing up thin set for the installation of material, mixing up of sand to cement for the installation of material and such other work as may be required in helping a Marble Setter in the handling of all material in the erection or installation of interior marble, slate, travertine, art marble, serpentine, alberene stone, blue stone, granite and other stones (meaning as to stone any foreign or domestic materials as are specified and used in building interiors and exteriors and customarily known as stone in the trade), carrara, sanionyx, vitrolite and similar opaque glass and the laying of all marble tile, terrazzo tile, slate tile and precast tile, steps, risers treads, base, or any other materials that may be used as substitutes for any of the aforementioned materials and which are used on interior and exterior which are installed in a similar manner.

MATERIAL TESTER I: Hand coring and drilling for testing of materials; field inspection of uncured concrete and asphalt.

MATERIAL TESTER II: Field inspection of welds, structural steel, fireproofing, masonry, soil, facade, reinforcing steel, formwork, cured concrete, and concrete and asphalt batch plants; adjusting proportions of bituminous mixtures.

OPERATING ENGINEER - BUILDING

Class 1. Asphalt Plant; Asphalt Spreader; Autograde; Backhoes with Caisson Attachment; Batch Plant; Benoto (requires Two Engineers); Boiler and Throttle Valve; Caisson Rigs; Central Redi-Mix Plant; Combination Back Hoe Front End-loader Machine; Compressor and Throttle Valve; Concrete Breaker (Truck Mounted); Concrete Conveyor; Concrete Conveyor (Truck Mounted); Concrete Paver Over 27E cu. ft.; Concrete Paver 27E cu. ft. and Under; Concrete Placer; Concrete Placing Boom; Concrete Pump (Truck Mounted); Concrete Tower; Cranes, All; Cranes, Hammerhead; Cranes, (GCI and similar Type); Creter Crane; Spider Crane; Crusher, Stone, etc.; Derricks, All; Derricks, Traveling; Formless Curb and Gutter Machine; Grader, Elevating; Grouting Machines; Heavy Duty Self-Propelled Transporter or Prime Mover; Highlift Shovels or Front Endloader 2-1/4 yd. and over; Hoists, Elevators, outside type rack and pinion and similar machines; Hoists, One, Two and Three Drum; Hoists, Two Tugger One Floor; Hydraulic Backhoes; Hydraulic Boom Trucks; Hydro Vac (and similar equipment); Locomotives, All; Motor Patrol; Lubrication Technician; Manipulators; Pile Drivers and Skid Rig; Post Hole Digger; Pre-Stress Machine; Pump Cretes Dual Ram; Pump Cretes: Squeeze Cretes-Screw Type Pumps; Gypsum Bulker and Pump; Raised and Blind Hole Drill; Roto Mill Grinder; Scoops - Tractor Drawn; Slip-Form Paver; Straddle Buggies; Operation of Tie Back Machine; Tournapull; Tractor with Boom and Side Boom; Trenching Machines.

Class 2. Boilers; Broom, All Power Propelled; Bulldozers; Concrete Mixer (Two Bag and Over); Conveyor, Portable; Forklift Trucks; Highlift Shovels or Front Endloaders under 2-1/4 yd.; Hoists, Automatic; Hoists, Inside Elevators; Hoists, Sewer Dragging Machine; Hoists, Tugger Single Drum; Laser Screed; Rock Drill (Self-Propelled); Rock Drill (Truck Mounted); Rollers, All; Steam Generators; Tractors, All; Tractor Drawn Vibratory Roller; Winch Trucks with "A" Frame.

Class 3. Air Compressor; Combination Small Equipment Operator; Generators; Heaters, Mechanical; Hoists, Inside Elevators (remodeling or renovation work); Hydraulic Power Units (Pile Driving, Extracting, and Drilling); Pumps, over 3" (1 to 3 not to exceed a total of 300 ft.); Low Boys; Pumps, Well Points; Welding Machines (2 through 5); Winches, 4 Small Electric Drill Winches.

Class 4. Bobcats and/or other Skid Steer Loaders; Oilers; and Brick Forklift.

Class 5. Assistant Craft Foreman. Class 6. Gradall.

Class 7. Mechanics; Welders.

OPERATING ENGINEERS - HIGHWAY CONSTRUCTION

Class 1. Asphalt Plant; Asphalt Heater and Planer Combination; Asphalt Heater Scarfire; Asphalt Spreader; Autograder/GOMACO or other similar type machines: ABG Paver; Backhoes with Caisson Attachment; Ballast Regulator; Belt Loader; Caisson Rigs; Car Dumper; Central Redi-Mix Plant; Combination Backhoe Front Endloader Machine, (1 cu. yd. Backhoe Bucket or over or with attachments); Concrete Breaker (Truck Mounted); Concrete Conveyor; Concrete Paver over 27E cu. ft.; Concrete Placer; Concrete Tube Float; Cranes, all attachments; Cranes, Tower Cranes of all types: Creter Crane; Spider Crane; Crusher, Stone, etc.; Derricks, All; Derrick Boats; Derricks, Traveling; Dredges; Elevators, Outside type Rack & Pinion and Similar Machines; Formless Curb and Gutter Machine; Grader, Elevating; Grader, Motor Grader, Motor Patrol, Auto Patrol, Form Grader, Pull Grader, Subgrader; Guard Rail Post Driver Truck Mounted; Hoists, One, Two and Three Drum; Heavy Duty Self-Propelled Transporter or Prime Mover; Hydraulic Backhoes; Backhoes with shear attachments up to 40' of boom reach; Lubrication Technician; Manipulators; Mucking Machine; Pile Drivers and Skid Rig; Pre-Stress Machine; Pump Cretes Dual Ram; Rock Drill - Crawler or Skid Rig; Rock Drill - Truck Mounted; Rock/Track Tamper; Roto Mill Grinder; Slip-Form Paver; Snow Melters; Soil Test Drill Rig (Truck Mounted); Straddle Buggies; Hydraulic Telescoping Form (Tunnel); Operation of Tieback Machine; Tractor Drawn Belt Loader; Tractor Drawn Belt Loader (with attached pusher - two engineers); Tractor with Boom; Tractaire with Attachments; Traffic Barrier Transfer Machine; Trenching; Truck Mounted Concrete Pump with Boom; Raised or Blind Hole Drills (Tunnel Shaft); Underground Boring and/or Mining Machines 5 ft. in diameter and over tunnel, etc; Underground Boring and/or Mining Machines under 5 ft. in diameter; Wheel Excavator; Widener (APSCO).

CENTRAL BOULEVARD IMPROVEMENTS VILLAGE OF VILLA PARK

Class 2. Batch Plant; Bituminous Mixer; Boiler and Throttle Valve; Bulldozers; Car Loader Trailing Conveyors; Combination Backhoe Front Endloader Machine (Less than 1 cu. yd. Backhoe Bucket or over or with attachments); Compressor and Throttle Valve; Compressor, Common Receiver (3); Concrete Breaker or Hydro Hammer; Concrete Grinding Machine; Concrete Mixer or Paver 7S Series to and including 27 cu. ft.; Concrete Spreader; Concrete Curing Machine, Burlap Machine, Belting Machine and Sealing Machine; Concrete Wheel Saw; Conveyor Muck Cars (Haglund or Similar Type); Drills, All; Finishing Machine - Concrete; Highlift Shovels or Front Endloader; Hoist - Sewer Dragging Machine; Hydraulic Boom Trucks (All Attachments); Hydro-Blaster; Hydro Excavating (excluding hose work); Laser Scream; All Locomotives, Dinky; Off-Road Hauling Units (including articulating) Non Self-Loading Ejection Dump; Pump Cretes: Squeeze Cretes - Screw Type Pumps, Gypsum Bulker and Pump; Roller, Asphalt; Rotary Snow Plows; Rototiller, Seaman, etc., self-propelled; Self-Propelled Compactor; Spreader - Chip - Stone, etc.; Scraper - Single/Twin Engine/Push and Pull; Scraper - Prime Mover in Tandem (Regardless of Size); Tractors pulling attachments, Sheeps Foot, Disc, Compactor, etc.; Tug Boats.

Class 3. Boilers; Brooms, All Power Propelled; Cement Supply Tender; Compressor, Common Receiver (2); Concrete Mixer (Two Bag and Over); Conveyor, Portable; Farm-Type Tractors Used for Mowing, Seeding, etc.; Forklift Trucks; Grouting Machine; Hoists, Automatic; Hoists, All Elevators; Hoists, Tugger Single Drum; Jeep Diggers; Low Boys; Pipe Jacking Machines; Post-Hole Digger; Power Saw, Concrete Power Driven; Pug Mills; Rollers, other than Asphalt; Seed and Straw Blower; Steam Generators; Stump Machine; Winch Trucks with "A" Frame; Work Boats; Tamper-Form-Motor Driven.

Class 4. Air Compressor; Combination - Small Equipment Operator; Directional Boring Machine; Generators; Heaters, Mechanical; Hydraulic Power Unit (Pile Driving, Extracting, or Drilling); Light Plants, All (1 through 5); Pumps, over 3" (1 to 3 not to exceed a total of 300 ft.); Pumps, Well Points; Vacuum Trucks (excluding hose work); Welding Machines (2 through 5); Winches, 4 Small Electric Drill Winches.

Class 5. SkidSteer Loader (all); Brick Forklifts; Oilers. Class 6. Field Mechanics and Field Welders
Class 7. Dowell Machine with Air Compressor; Gradall and machines of like nature.

OPERATING ENGINEER - FLOATING

Diver. Diver Wet Tender, Diver Tender, ROV Pilot, ROV Tender

SURVEY WORKER - Operated survey equipment including data collectors, G.P.S. and robotic instruments, as well as conventional levels and transits.

TRUCK DRIVER - BUILDING, HEAVY AND HIGHWAY CONSTRUCTION

Class 1. Two or three Axle Trucks. A-frame Truck when used for transportation purposes; Air Compressors and Welding Machines, including those pulled by cars, pick-up trucks and tractors; Ambulances; Batch Gate Lockers; Batch Hopperman; Car and Truck Washers; Carry-alls; Fork Lifts and Hoisters; Helpers; Mechanics Helpers and Greasers; Oil Distributors 2-man operation; Pavement Breakers; Pole Trailer, up to 40 feet; Power Mower Tractors; Self-propelled Chip Spreader; Skipman; Slurry Trucks, 2-man operation; Slurry Truck Conveyor Operation, 2 or 3 man; Teamsters; Unskilled Dumpman; and Truck Drivers hauling warning lights, barricades, and portable toilets on the job site.

Class 2. Four axle trucks; Dump Crets and Adgetors under 7 yards; Dumpsters, Track Trucks, Euclids, Hug Bottom Dump Turnapulls or Turnatrailers when pulling other than self-loading equipment or similar equipment under 16 cubic yards; Mixer Trucks under 7 yards; Ready-mix Plant Hopper Operator, and Winch Trucks, 2 Axles.

Class 3. Five axle trucks; Dump Crets and Adgetors 7 yards and over; Dumpsters, Track Trucks, Euclids, Hug Bottom Dump Turnatrailers or turnapulls when pulling other than self-loading equipment or similar equipment over 16 cubic yards; Explosives and/or Fission Material Trucks; Mixer Trucks 7 yards or over; Mobile Cranes while in transit; Oil Distributors, 1-man operation; Pole Trailer, over 40 feet; Pole and Expandable Trailers hauling material over 50 feet long; Slurry trucks, 1-man operation; Winch trucks, 3 axles or more; Mechanic--Truck Welder and Truck Painter.

Class 4. Six axle trucks; Dual-purpose vehicles, such as mounted crane trucks with hoist and accessories; Foreman; Master Mechanic; Self-loading equipment like P.B. and trucks with scoops on the front.

TERRAZZO FINISHER

The handling of sand, cement, marble chips, and all other materials that may be used by the Mosaic Terrazzo Mechanic, and the mixing, grinding, grouting, cleaning and sealing of all Marble, Mosaic, and Terrazzo work, floors, base, stairs, and wainscoting by hand or machine, and in addition, assisting and aiding Marble, Masonic, and Terrazzo Mechanics.

Other Classifications of Work:

For definitions of classifications not otherwise set out, the Department generally has on file such definitions which are available. If a task to be performed is not subject to one of the classifications of pay set out, the Department will upon being contacted state which neighboring county has such a classification and provide such rate, such rate being deemed to exist by reference in this document. If no neighboring county rate applies to the task, the Department shall undertake a special determination, such special determination being then deemed to have existed under this determination. If a project requires these, or any classification not listed, please contact IDOL at 217-782-1710 for wage rates or clarifications.

LANDSCAPING

Landscaping work falls under the existing classifications for laborer, operating engineer and truck driver.

**CENTRAL BOULEVARD IMPROVEMENTS
VILLAGE OF VILLA PARK**

The work performed by landscape plantsman and landscape laborer is covered by the existing classification of laborer. The work performed by landscape operators (regardless of equipment used or its size) is covered by the classifications of operating engineer. The work performed by landscape truck drivers (regardless of size of truck driven) is covered by the classifications of truck driver.

MATERIAL TESTER & MATERIAL TESTER/INSPECTOR I AND II

Notwithstanding the difference in the classification title, the classification entitled "Material Tester I" involves the same job duties as the classification entitled "Material Tester/Inspector I". Likewise, the classification entitled "Material Tester II" involves the same job duties as the classification entitled "Material Tester/Inspector II".

NOT FOR BID

NOT FOR BID

CENTRAL BOULEVARD IMPROVEMENTS
VILLAGE OF VILLA PARK

APPENDIX 2

IDOT STANDARD DETAILS

NOT FOR BID

NOT FOR BID

ABV	ABOVE	CU YD	CUBIC YARD	HD	HEAD	PED	PEDESTAL	STD	STANDARD
A/C	ACCESS CONTROL	CULV	CULVERT	HDW	HEADWALL	PNT	POINT	SBI	STATE BOND ISSUE
AC	ACRE	C&G	CURB & GUTTER	HDUTY	HEAVY DUTY	PC	POINT OF CURVATURE	SR	STATE ROUTE
ADJ	ADJUST	D	DEGREE OF CURVE	HA	HECTARE	PI	POINT OF INTERSECTION OF HORIZONTAL CURVE	STA	STATION
AS	AERIAL SURVEYS	DC	DEPRESSED CURVE	HMA	HOT MIX ASPHALT	PRC	POINT OF REVERSE CURVE	SS	STEEL PLATE BEAM GUARDRAIL
ASG	AGGREGATE	DET	DETECTOR	HWY	HIGHWAY	PT	POINT OF TANGENCY	SS	STORM SEWER
AH	AHEAD	DIA	DIAMETER	HORIZ	HORIZONTAL	POT	POINT ON TANGENT	ST	STREET
APT	APARTMENT	DIST	DISTRICT	HSE	HOUSE	POLYETH	POLYETHYLENE	STR	STRUCTURE
ASPH	ASPHALT	DOM	DOMESTIC	IMP	IMPROVEMENT	PCC	PORTLAND CEMENT CONCRETE	e	SUPERELEVATION RATE
AUX	AUXILIARY	DSL	DOUBLE	IN DIA	INCH DIAMETER	PP	POWER POLE OR PRINCIPAL POINT	S.E. RUN.	SUPERELEVATION RUNOFF LENGTH
AGS	AUXILIARY GAS VALVE (SERVICE)	DSFL	DOWNSTREAM FLOWLINE	INL	INLET	PRM	PRIME	SURF	SURFACE
AVE	AVENUE	DR	DRAINAGE OR DRIVE	INST	INSTALLATION	PE	PRIVATE ENTRANCE	SMK	SURVEY MARKER
AX	AXIS OF ROTATION	DI	DRAINAGE INLET OR DROP INLET	IDS	INTERSECTION DESIGN STUDY	PROF	PROFILE	T	TANGENT DISTANCE
BK	BACK	DRV	DRIVEWAY	INV	INVERT	PGL	PROFILE GRADELINE	T.R.	TANGENT RUNOUT DISTANCE
B-B	BACK TO BACK	DCT	DUCT	IP	IRON PIPE	PROJ	PROJECT	TEL	TELEPHONE
BKPL	BACKPLATE	DCT	DUCT	IR	IRON ROD	P.C.	PROPERTY CORNER	TB	TELEPHONE BOX
B	BARN	EA	EASTBOUND	IT	JOINT	PL	PROPERTY LINE	TP	TEMPORARY
BARR	BARRICADE	EB	EDGE OF ROAD	JT	JOINT	PR	PROPOSED	TEMP	TEMPORARY
BGN	BEGIN	EOP	EDGE OF PAVEMENT	KG	KILOGRAM	PR	PROPOSED	TBW	TEMPORARY BENCH MARK
BM	BENCHMARK	E-CL	EDGE TO CENTERLINE	Km	KILOMETER	RD	RADIUS	TD	TILE DRAIN
BL	BINDER	E-E	EDGE TO EDGE	LS	LANDSCAPING	R	RAILROAD	TR	TOWNSHIP ROAD
BIT	BITUMINOUS	EL	ELEVATION	LN	LANE	RRS	RAILROAD SPIKE	TS	TRAFFIC SIGNAL
BTM	BOTTOM	E-CL	EDGE TO CENTERLINE	LP	LEFT	RPS	REFERENCE POINT STAKE	TSCB	TRAFFIC SIGNAL CONTROL BOX
BLVD	BOULEVARD	E-E	EDGE TO EDGE	LT	LEFT	REF	REFLECTIVE	TBR	TRAFFIC SYSTEMS CENTER
BRK	BRICK	ENTR	ENTRANCE	LP	LIGHT POLE	RCCP	REINFORCED CONCRETE CULVERT PIPE	TBS	TO BE SAVED
BBOX	BUFFALO BOX	EXC	EXCAVATION	LGT	LIGHTING	REINF	REINFORCEMENT	TWP	TOWNSHIP
BRK	BRICK	EX	EXISTING	LF	LINEAL FEET OR LINEAR FEET	REIN	REINFORCEMENT	TR	TOWNSHIP ROAD
BLDG	BUILDING	EXPWAY	EXPRESSWAY	LF	LINEAL FEET OR LINEAR FEET	REIN	REINFORCEMENT	TS	TRAFFIC SIGNAL
BLDG	BUILDING	E	EXTERNAL DISTANCE OF HORIZONTAL CURVE	L	LITER OR CURVE LENGTH	RC	REMOVE CROWN	TSCB	TRAFFIC SIGNAL CONTROL BOX
CIP	CAST IRON PIPE	E	EXTERNAL DISTANCE OF HORIZONTAL CURVE	L	LITER OR CURVE LENGTH	REP	REPLACEMENT	TSC	TRAFFIC SYSTEMS CENTER
CB	CATCH BASIN	F-F	FACE TO FACE	LNG	LONGITUDINAL	REST	RESTAURANT	TRVS	TRANSVERSE
C-C	CENTERLINE TO CENTERLINE OR CLEARANCE	FA	FEDERAL AID	L SLUM	LUMP SUM	RESURF	RESURFACING	TRVL	TRAVEL
CL	CENTERLINE OR CLEARANCE	FAI	FEDERAL AID INTERSTATE	MACH	MACHINE	RET	RETAINING	TRN	TURN
CL-E	CENTERLINE TO EDGE	FAP	FEDERAL AID PRIMARY	MB	MAIL BOX	RT	RIGHT	TY	TYPE
CL-F	CENTERLINE TO FACE	FAS	FEDERAL AID SECONDARY	MH	MANHOLE	RT	RIGHT	TY	TYPE
CTS	CENTERS	FAUS	FEDERAL AID URBAN SECONDARY	MATL	MATERIAL	ROW	RIGHT-OF-WAY	T-A	TYPE A
CERT	CERTIFIED	FP	FENCE POST	MED	MEDIAN	RD	ROAD	TYP	TYPICAL
CHSLD	CHISELED	FE	FIELD ENTRANCE	M	METHOD	RDWY	ROADWAY	UNDGND	UNDERGROUND
CS	CITY STREET	FH	FIRE HYDRANT	METH	METHOD	RTE	ROUTE	USGS	U.S. GEOLOGICAL SURVEY
CP	CLAY PIPE	FL	FLOW LINE	M	MID-ORDINATE	SAN	SANITARY	USEL	UPSTREAM ELEVATION
CLSD	CLOSED	FB	FOOT BRIDGE	M	MILLIMETER	SANS	SANITARY SEWER	USFL	UPSTREAM FLOWLINE
CLID	CLOSED LID	FDN	FOUNDATION	mm	MILLIMETER DIAMETER	SEC	SECTION	UTIL	UTILITY
CT	COAT OR COURT	FR	FRAME	MIX	MIXTURE	SEED	SEEDING	VBOX	VALVE BOX
COMB	COMBINATION	F&G	FRAME & GRATE	MBH	MOBILE HOME	SHAP	SHAPING	VV	VALVE VAULT
C	COMMERCIAL BUILDING	FRWAY	FREWAY	MOD	MODIFIED	S	SHED	VLT	VAULT
CE	COMMERCIAL ENTRANCE	GAL	GALLON	MFT	MOTOR FUEL TAX	SH	SHEET	VEH	VEHICLE
CE	CONCRETE	GALV	GALVANIZED	N & BC	NAIL & BOTTLE CAP	SHLD	SHOULDER	VP	VENT PIPE
CONC	CONCRETE	G	GARAGE	N & C	NAIL & CAP	SHD	SHOULDER OR SOUTHWEST	VERT	VERTICAL
CONST	CONSTRUCT	GM	GAS METER	N & W	NAIL & WASHER	SIG	SIGNAL	VC	VERTICAL CURVE
CONTD	CONTINUED	G	GAS METER	NOAA	NATIONAL OCEANIC ATMOSPHERIC ADMINISTRATION	SOD	SODDING	VPC	VERTICAL POINT OF INTERSECTION
CONTD	CONTINUED	GM	GAS METER	NC	NORMAL CROWN	SM	SOLID MEDIUM	VPI	VERTICAL POINT OF INTERSECTION
CONT	CONTINUOUS	GRAN	GRANULAR	NE	NORTHBOUND	SOD	SODDING	VPT	VERTICAL POINT OF TANGENCY
COR	CORNER	GR	GRATE	NB	NORTHBOUND	SE	SOUTHBOUND	WM	WATER METER
CORR	CORRUGATED	GRV	GRAVEL	NE	NORTHBOUND	SE	SOUTHBOUND	WM	WATER METER
CMP	CORRUGATED METAL PIPE	GND	GROUND	NW	NORTHWEST	SPL	SPECIAL	WV	WATER VALVE
CNTY	COUNTY	GUT	GUTTER	NW	NORTHWEST	SD	SPECIAL DITCH	WMAIN	WATER MAIN
CH	COUNTY HIGHWAY	GP	GUY POLE	OLID	OPEN LID	SO FT	SQUARE FEET	WB	WESTBOUND
CSE	COURSE	GW	GUY WIRE	PAT	PATTERN	m 2	SQUARE METER	WLDL	WILDFLOWERS
XSECT	CROSS SECTION	HH	HANDHOLE	PVD	PAVED	mm 2	SQUARE MILLIMETER	W	WITH
m ³	CUBIC METER	HH	HANDHOLE	PVMT	PAVED	mm 2	SQUARE MILLIMETER	WO	WITHOUT
mm ³	CUBIC MILLIMETER	HATCH	HATCHING	PM	PAVEMENT MARKING	STB	STABILIZED		

 Illinois Department of Transportation
 PASSED January 1, 2011
 ENGINEER OF POLICY AND PROCEDURES
 APPROVED January 1, 2011
 ENGINEER OF DESIGN AND ENVIRONMENT









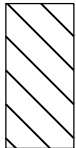

ISSUED 1-1-97





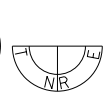



DATE	REVISIONS
1-1-11	Updated abbreviations and symbols.
1-1-08	Updated abbreviations and symbols.

STANDARD SYMBOLS, ABBREVIATIONS AND PATTERNS
 (Sheet 1 of 8)

STANDARD 000001-06

<u>ADJUSTMENT ITEMS</u>	<u>EX</u>	<u>PR</u>
Structure To Be Adjusted		ADJ
Structure To Be Cleaned		C
Main Structure To Be Filled		FM
Structure To Be Filled		F
Structure To Be Filled Special		FSP
Structure To Be Removed		R
Structure To Be Reconstructed		REC
Structure To Be Reconstructed Special		RSP
Frame and Grate To Be Adjusted		A
Frame and Lid To Be Adjusted		A
Domestic Service Box To Be Adjusted		A
Valve Vault To Be Adjusted		A
Special Adjustment		SP
Item To Be Abandoned		AB
Item To Be Moved		M
Item To Be Relocated		REL
Pavement Removal and Replacement		

<u>ALIGNMENT ITEMS</u>	<u>EX</u>	<u>PR</u>
Baseline	_____	_____
Centerline	_____	_____
Centerline Break Circle	○	○
Baseline Symbol		
Centerline Symbol		
PI Indicator	△	△
Point Indicator	○	○
Horizontal Curve Data (Half Size)	CURVE P.I. STA= Δ= D= R= T= L= E= θ= T.R.= S.E. RUN= P.C. STA= P.T. STA=	CURVE P.I. STA= Δ= D= R= T= L= E= θ= T.R.= S.E. RUN= P.C. STA= P.T. STA=
<u>BOUNDARIES ITEMS</u>	<u>EX</u>	<u>PR</u>
Dashed Property Line	---	---
Solid Property/Lot Line	_____	_____
Section/Grant Line	_____	_____
Quarter Section Line	_____	_____
Quarter/Quarter Section Line	_____	_____
County/Township Line	_____	_____
State Line	- · - · -	- · - · -
Iron Pipe Found	○	○
Iron Pipe Set	●	●
Survey Marker		
Property Line Symbol	P	P
Same Ownership Symbol (Half Size)		
Northwest Quarter Corner (Half Size)		
Section Corner (Half Size)		
Southeast Quarter Corner (Half Size)		

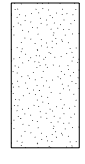
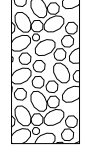
<u>CONTOUR ITEMS</u>	<u>EX</u>	<u>PR</u>
Approx. Index Line	---	---
Approx. Intermediate Line	---	---
Index Contour	_____	_____
Intermediate Contour	_____	_____
<u>DRAINAGE ITEMS</u>	<u>EX</u>	<u>PR</u>
Channel or Stream Line	---	---
Culvert Line	- - - -	_____
Grading & Shaping Ditches	_____	_____
Drainage Boundary Line	////	////
Paved Ditch	-----	-----
Aggregate Ditch	-----	-----
Pipe Underdrain	-----	-----
Storm Sewer	-----	-----
Flowline	ft	ft
Ditch Check		
Headwall	-	
Inlet	□	□
Manhole	⊙	⊙
Summit	↔	↔
Roadway Ditch Flow		
Swale		
Catch Basin	○	●
Culvert End Section	△	▲
Water Surface Indicator		
Ribrap		

STANDARD SYMBOLS, ABBREVIATIONS AND PATTERNS
(Sheet 2 of 8)

STANDARD 000001-06

Illinois Department of Transportation

PASSED January 1, 2011

ENGINEER OF POLICY AND PROCEDURES
Michael R. Bond

APPROVED January 1, 2011

ENGINEER OF DESIGN AND ENVIRONMENT
Shafton X

ISSUED 1-1-97

<u>EROSION & SEDIMENT CONTROL ITEMS</u>	<u>NON-HIGHWAY IMPROVEMENT ITEMS</u>	<u>EXISTING LANDSCAPING ITEMS (contd.)</u>
EX	EX	EX
PR	PR	PR
Cleaning & Grading Limits	Noise Attn./Levee	Seeding Class 5
Dike	Field Line	Seeding Class 7
Erosion Control Fence	Fence	Seedlings Type 1
Perimeter Erosion Barrier	Base of Levee	Seedlings Type 2
Temporary Fence	Mailbox	Sodding
Ditch Check Temporary	Multiple Mailboxes	Mowstake w/Sign
Ditch Check Permanent	Pay Telephone	Tree Trunk Protection
Inlet & Pipe Protection	Advertising Sign	Evergreen Tree
Sediment Basin	Contour Mounding Line	Shade Tree
Erosion Control Blanket	Fence	LIGHTING
Fabric Formed Concrete Revetment Mat	Fence Post	Duct
Turf Reinforcement Mat	Shrubs	Conduit
Mulch Temporary	Mowline	Electrical Aerial Cable
Mulch Method 1	Perennial Plants	Electrical Buried Cable
Mulch Method 2 Stabilized	Seeding Class 2	Controller
Mulch Method 3 Hydraulic	Seeding Class 2A	Underpass Luminaire
	Seeding Class 4	Power Pole
	Seeding Class 4 & 5 Combined	
	LANDSCAPING ITEMS	
	Fence	
	Fence Post	
	Shrubs	
	Mowline	
	Perennial Plants	
	Seeding Class 2	
	Seeding Class 2A	
	Seeding Class 4	
	Seeding Class 4 & 5 Combined	
	LIGHTING	
	Duct	
	Conduit	
	Electrical Aerial Cable	
	Electrical Buried Cable	
	Controller	
	Underpass Luminaire	
	Power Pole	

 Illinois Department of Transportation
 PASSED January 1, 2011
 ENGINEER OF POLICY AND PROCEDURES
 APPROVED January 1, 2011
 ENGINEER OF DESIGN AND ENVIRONMENT

ISSUED 1-1-97

STANDARD SYMBOLS, ABBREVIATIONS AND PATTERNS
 (Sheet 3 of 8)
STANDARD 000001-06

LIGHTING
(contd.)

	EX	PR
Pull Point		
Handhole		
Heavy Duty Handhole		
Junction Box		
Light Unit Comb.		
Electrical Ground		
Traffic Flow Arrow		
High Mast Pole (Half Size)		
Light Unit-1		

PAVEMENT (MISC.)

	EX	PR
Keyed Long. Joint		
Keyed Long. Joint w/Tie Bars		
Sawed Long. Joint w/Tie Bars		
Bituminous Shoulder		
Bituminous Taper		
Stabilized Driveway		
Widening		

PAVEMENT MARKINGS

	EX	PR
Bike Lane Symbol		
Bike Lane Text		
Handicap Symbol		
RR Crossing		
Raised Marker Amber 1 Way		
Raised Marker Amber 2 Way		
Raised Marker Crystal 1 Way		
Two Way Turn Left		
Shoulder Diag. Pattern		
Skip-Dash White		
Skip-Dash Yellow		
Stop Line		
Solid Line		
Double Centerline		
Dotted Lines		
CL 2Ln 2Way RRPM 12.2 m (40') o.c.		
CL 2Ln 2Way RRPM 80' (24.4 m) o.c.		
CL Multilane Div. RRPM 40' (12.2 m) o.c.		
CL Multilane Div. RRPM 80' (24.4 m) o.c.		
CL Multilane Div. Dbl. RRPM 80' (24.4 m) o.c.		
CL Multilane Undiv.		
Two Way Turn Left Line		

NOT FOR BID

	PR

**STANDARD SYMBOLS,
ABBREVIATIONS
AND PATTERNS**
(Sheet 4 of 8)

STANDARD 000001-06

Illinois Department of Transportation
 PASSED January 1, 2011
 ENGINEER OF POLICY AND PROCEDURES
 APPROVED January 1, 2011
 ENGINEER OF DESIGN AND ENVIRONMENT

ISSUED 1-1-97

PAVEMENT MARKINGS
(contd.)

	EX	PR
Urban Combination Left		
Urban Combination Right		
Urban Left Turn Arrow		
Urban Right Turn Arrow		
Urban Left Turn Only		
Urban Right Turn Only		
Urban Thru Only		
Urban U-Turn		
Urban Combined U-Turn		
Rural Combination Left		
Rural Combination Right		
Rural Left Turn Arrow		
Rural Right Turn Arrow		
Rural Left Turn Only		
Rural Right Turn Only		
Rural Thru Only		

RAILROAD ITEMS

	EX	PR
Abandoned Railroad		
Railroad		
Railroad Point		
Control Box		
Crossing Gate		
Flashing Signal		
Railroad Cont., Mast Arm		
Crossbuck		

REMOVAL ITEMS

	EX	PR
Removal Tic		
Bituminous Removal		
Hatch Pattern		
Tree Removal Single		

RIGHT OF WAY ITEMS

	EX	PR
Future ROW Corner Monument		
ROW Marker		
ROW Line		
Easement		
Temporary Easement		

STANDARD SYMBOLS, ABBREVIATIONS AND PATTERNS
(Sheet 5 of 8)

STANDARD 000001-06

Illinois Department of Transportation
 PASSED January 1, 2011
 ENGINEER OF POLICY AND PROCEDURES
 APPROVED January 1, 2011
 ENGINEER OF DESIGN AND ENVIRONMENT

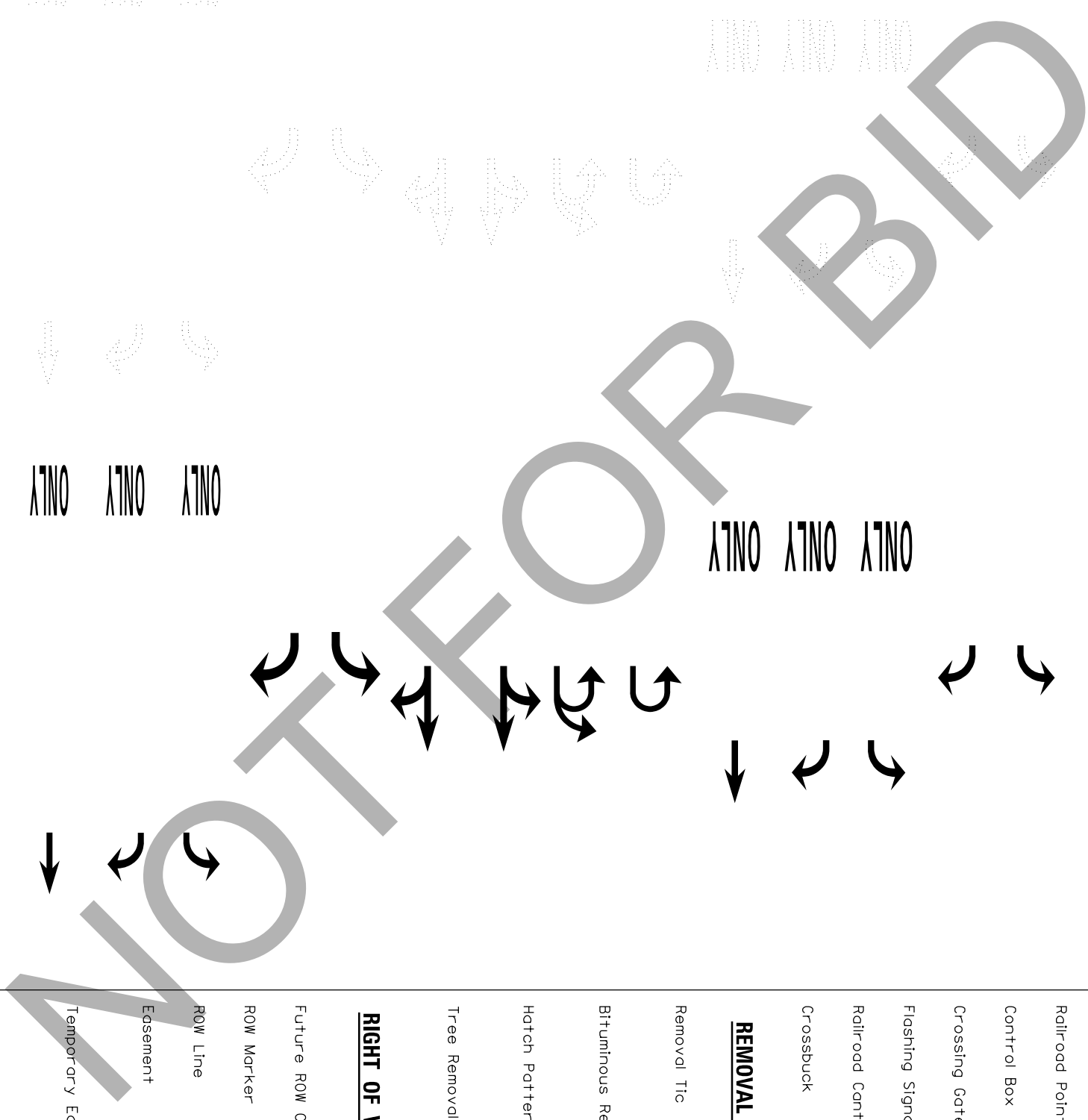

RIGHT OF WAY ITEMS (contd.)	EX	PR
Access Control Line	— AC —	— AC —
Access Control Line & ROW	— AC —	— AC —
Access Control Line & ROW with Fence	x — AR —	· x — AC —
Excess ROW Line		— XS —

ROADWAY PLAN ITEMS	EX	PR
Cable Barrier		
Concrete Barrier		
Edge of Pavement	---	---
Bit Shoulders, Medians and C&G Line	---	---
Aggregate Shoulder	---	---
Sidewalks, Driveways	---	---
Guard-rail		
Guard-rail Post	o	o
Traffic Sign	p	h
Corrugated Median		
Impact Attenuator		
North Arrow with District Office (Half Size)		
Match Line	---	— STA. 45+00
Slope Limit Line	---	
Typical Cross-Section Line	---	

ROADWAY PROFILES	EX	PR
P.I. Indicator	▲	▲
Point Indicator	o	o
Earthworks Balance Point		
Begin Point		
Vert. Curve Data	$\begin{matrix} VPI = \\ ELEV = \\ E \end{matrix}$	$\begin{matrix} VPI = \\ ELEV = \\ E \end{matrix}$
Ditch Profile Left Side	---	---
Ditch Profile Right Side	---	---
Roadway Profile Line	---	---
Storm Sewer Profile Left Side	---	---
Storm Sewer Profile Right Side	---	---

SIGNING ITEMS	EX	PR
Cone, Drum or Barricade	o	o
Barricade Type II		
Barricade Type III		
Barricade with Edge Line		
Flashing Light Sign		
Panel I		
Panel II		
Direction of Traffic		
Sign Flag (Half Size)		

SIGNING ITEMS (contd.)	EX	PR
Reverse Left W1-4L (Half Size)		
Reverse Right W1-4R (Half Size)		
Two Wgy Traffic Sign W6-3 (Half Size)		
Detour Ahead W20-2(0) (Half Size)		
Left Lane Closed Ahead W20-5L(0) (Half Size)		
Right Lane Closed Ahead W20-5R(0) (Half Size)		
Road Closed Ahead W20-3(0) (Half Size)		
Road Construction Ahead W20-1-(0) (Half Size)		
Single Lane Ahead (Half Size)		
Transition Left W4-2L (Half Size)		
Transition Right W4-2R (Half Size)		

STANDARD SYMBOLS, ABBREVIATIONS AND PATTERNS (Sheet 6 of 8)	
STANDARD	000001-06

Illinois Department of Transportation
 PASSED January 1, 2011
 ENGINEER OF POLICY AND PROCEDURES
 APPROVED January 1, 2011
 ENGINEER OF DESIGN AND ENVIRONMENT

<u>SIGNING ITEMS</u> <u>(contd.)</u>	<u>EX</u>	<u>PR</u>	<u>EX</u>	<u>PR</u>	<u>STRUCTURES ITEMS</u>	<u>EX</u>	<u>PR</u>	<u>TRAFFIC SHEET ITEMS</u>	<u>EX</u>	<u>PR</u>
One Way Arrow Lrg. W1-6-(0) (Half Size)					Cable Number					
Two Way Arrow Large W1-7-(0) (Half Size)					Left Turn Green					
Detour M4-10L-(0) (Half Size)					Left Turn Yellow					
Detour M4-10R-(0) (Half Size)					Signal Backplate					
One Way Left R6-1L (Half Size)					Signal Section 8" (200 mm)					
One Way Right R6-1R (Half Size)					Signal Section 12" (300 mm)					
Left Turn Lane R3-1100L (Half Size)					Walk/Don't Walk Letters					
Keep Left R4-7AL (Half Size)					Walk/Don't Walk Symbols					
Keep Left R4-7BL (Half Size)					<u>TRAFFIC SIGNAL ITEMS</u>			<u>TRAFFIC SIGNAL ITEMS</u>		<u>TRAFFIC SIGNAL ITEMS</u>
Keep Right R4-7AR (Half Size)					Galv. Steel Conduit					
Keep Right R4-7BR (Half Size)					Underground Cable					
Stop Here On Red R10-6-AL (Half Size)					Detector Loop Line					
Stop Here On Red R10-6-AR (Half Size)					Detector Loop Large					
No Left Turn R3-2 (Half Size)					Detector Loop Small					
Road Closed R11-2 (Half Size)					Detector Loop Quadrangle					
Road Closed Thru Traffic R11-2 (Half Size)										

Illinois Department of Transportation

PASSED January 1, 2011
 Michael R. Bond
 ENGINEER OF POLICY AND PROCEDURES

APPROVED January 1, 2011
 Saif Sheikh
 ENGINEER OF DESIGN AND ENVIRONMENT

ISSUED 1-1-97

**STANDARD SYMBOLS,
 ABBREVIATIONS
 AND PATTERNS**

(Sheet 7 of 8)

STANDARD 000001-06

TRAFFIC SIGNAL ITEMS (contd.)	EX	PR
Detector Raceway		
Aluminum Mast Arm		
Steel Mast Arm		
Veh. Detector Magnetic		
Conduit Splice		
Controller		
Gulftbox Junction		
Wood Pole		
Temp. Signal Head		
Handhole		
Double Handhole		
Heavy Duty Handhole		
Junction Box		
Red. Pushbutton Detector		
Red. Signal Head		
Power Pole Service		
Pri-ority Veh. Detector		
Signal Head		
Signal Head w/Backplate		
Signal Post		
Closed Circuit TV		
Video Detector System		

UNDERGROUND UTILITY ITEMS	EX	PR	ABANDONED
Cable TV			
Electric Cable			
Fiber Optic			
Gas Pipe			
Oil Pipe			
Sanitary Sewer			
Telephone Cable			
Water Pipe			

UTILITIES ITEMS	EX	PR
Controller		
Double Handhole		
Fire Hydrant		
GuyWire or Deadman Anchor		
Handhole		
Heavy Duty Handhole		
Junction Box		
Light Pole		
Manhole		
Pipeline Warning Sign		
Power Pole		
Power Pole with Light		
Sanitary Sewer Cleanout		
Splice Box Above Ground		
Telephone Splice Box Above Ground		
Telephone Pole		

UTILTY ITEMS (contd.)	EX	PR
Traffic Signal		
Traffic Signal Control Box		
Water Meter		
Water Meter Valve Box		
Profile Line		
Aerial Power Line		

VEGETATION ITEMS	EX	PR
Deciduous Tree		
Bush or Shrub		
Evergreen Tree		
Stump		
Orchard/Nursery Line		
Vegetation Line		
Woods & Bush Line		

WATER FEATURE ITEMS	EX	PR
Stream or Drainage Ditch		
Waters Edge		
Water Surface Indicator		
Water Point		
Disappearing Ditch		
Marsh		
Marsh/Swamp Boundary		

Illinois Department of Transportation
 PASSED January 1, 2011
 ENGINEER OF POLICY AND PROCEDURES
 APPROVED January 1, 2011
 ENGINEER OF DESIGN AND ENVIRONMENT

STANDARD SYMBOLS, ABBREVIATIONS AND PATTERNS
 STANDARD 000001-06
 (Sheet 8 of 8)

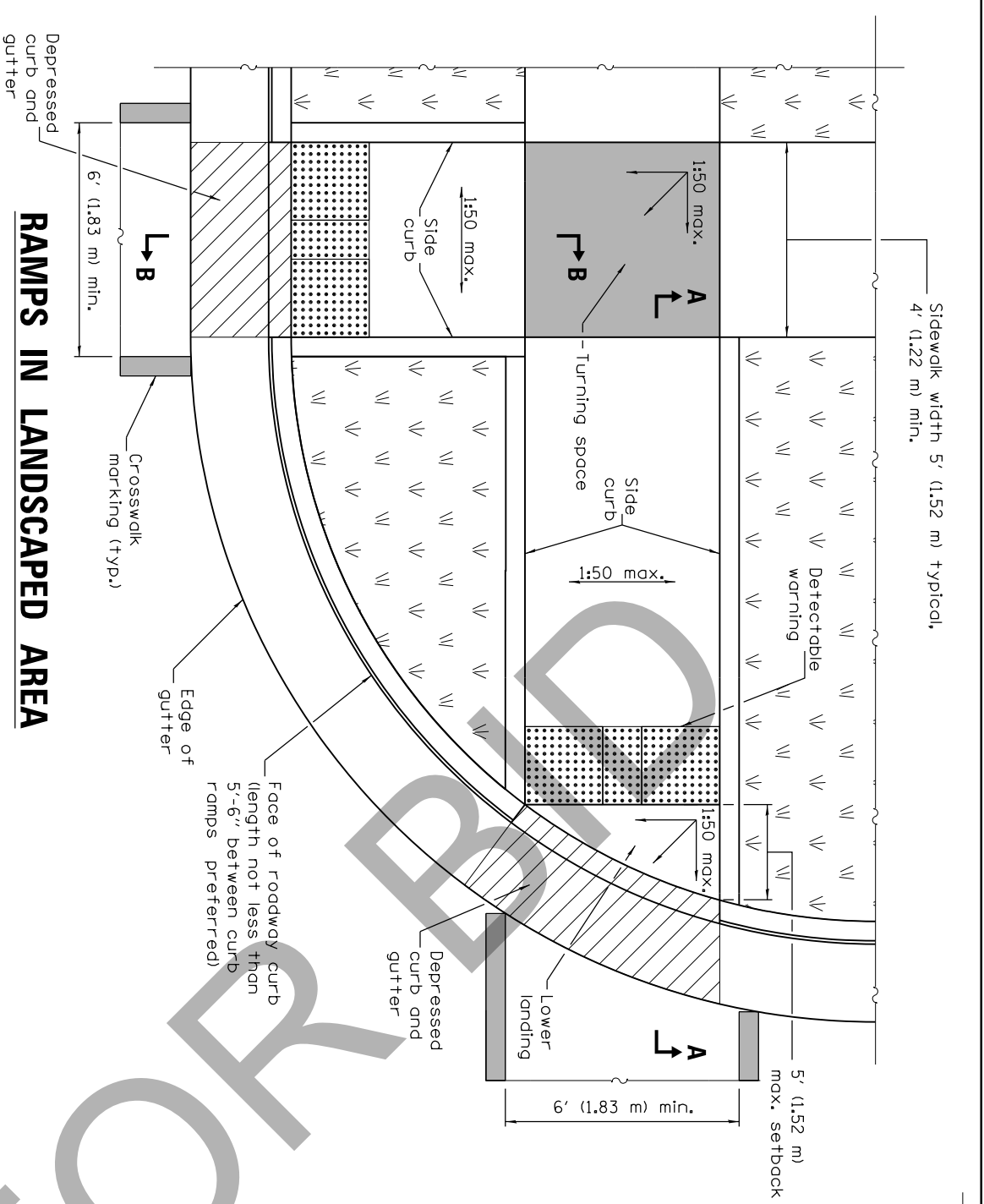

RAMPS IN LANDSCAPED AREA

SETBACK \leq 5'

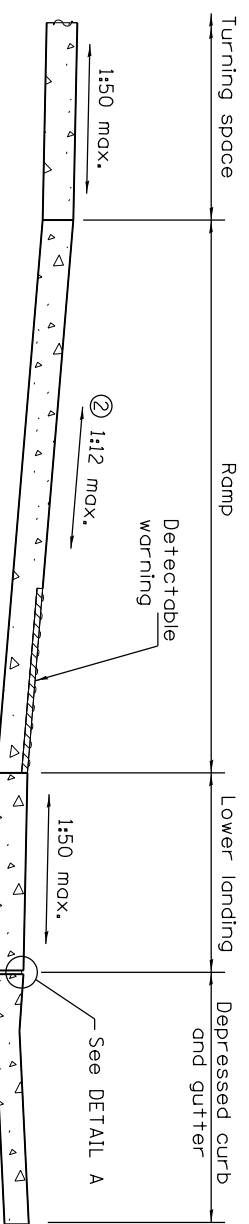

SECTION A-A

② The running slope of the curb ramp shall not require the ramp length to exceed 15' (4.5 m).

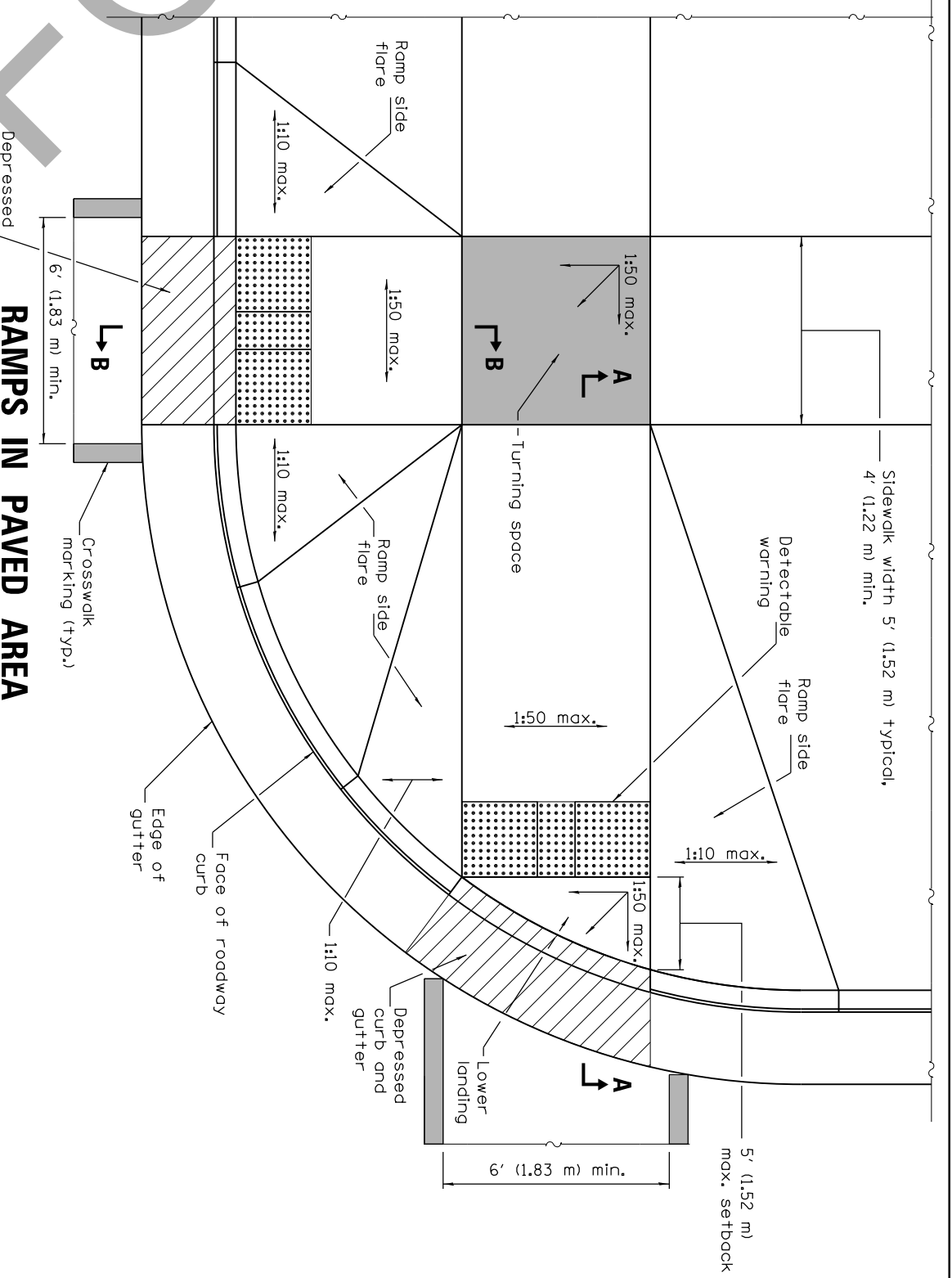

RAMPS IN PAVED AREA

SETBACK \leq 5'

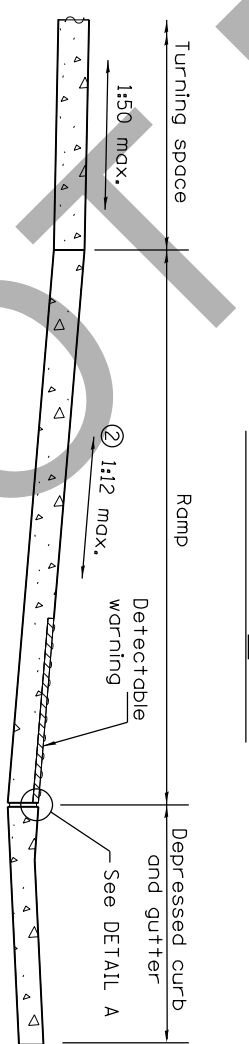

SECTION B-B

② The running slope of the curb ramp shall not require the ramp length to exceed 15' (4.5 m).

Illinois Department of Transportation
 PASSED January 1, 2015
 ENGINEER OF POLICY AND PROCEDURES
 APPROVED January 1, 2015
 ENGINEER OF DESIGN AND ENVIRONMENT

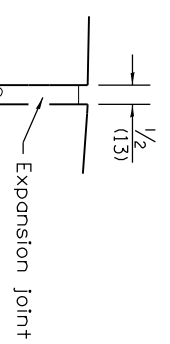

DETAIL A

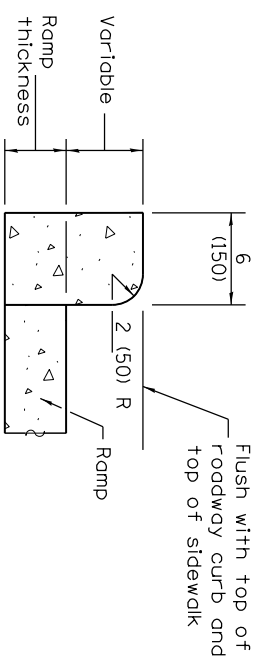

SIDE CURB DETAIL

See Sheet 2 for GENERAL NOTES.

DATE	REVISIONS
1-1-15	① not appl. to int. sidewalks, Rev. gen. notes, Ch'd Upper landing to Turning space.
1-1-13	Widened crosswalk markings to 6' (1.83 m) min. inside dimension. Rev. Gen. Notes.

PERPENDICULAR CURB RAMPS FOR SIDEWALKS
 STANDARD 424001-08
 (Sheet 1 of 2)

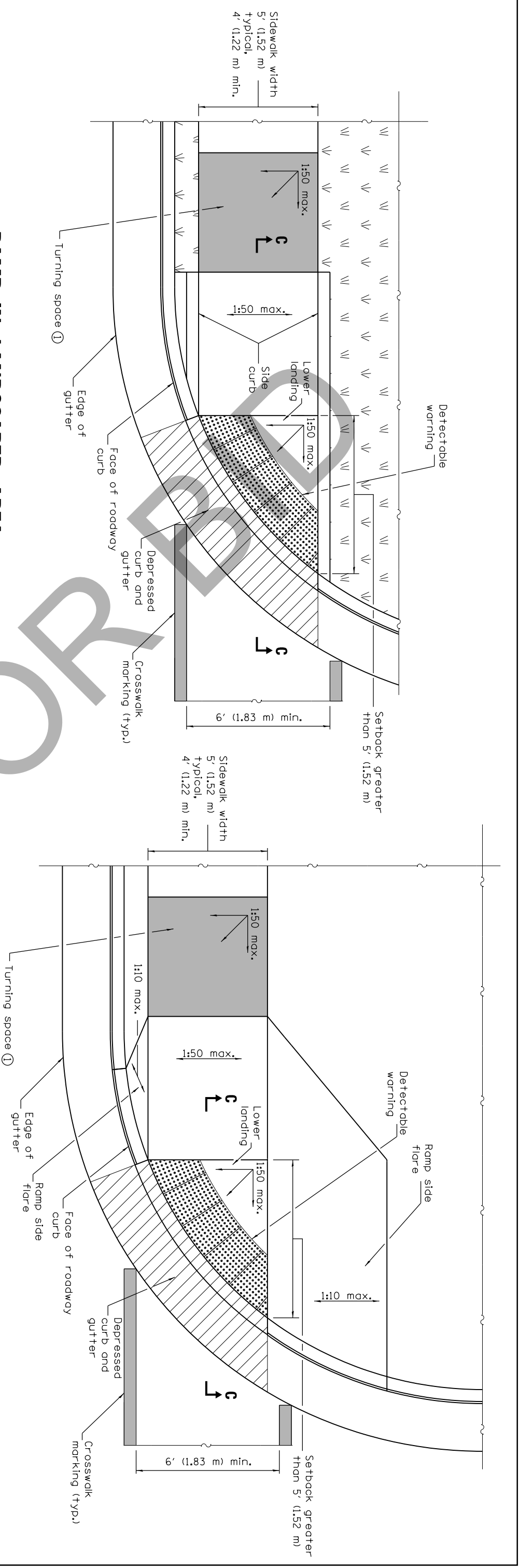

RAMP IN PAVED AREA
SETBACK > 5'

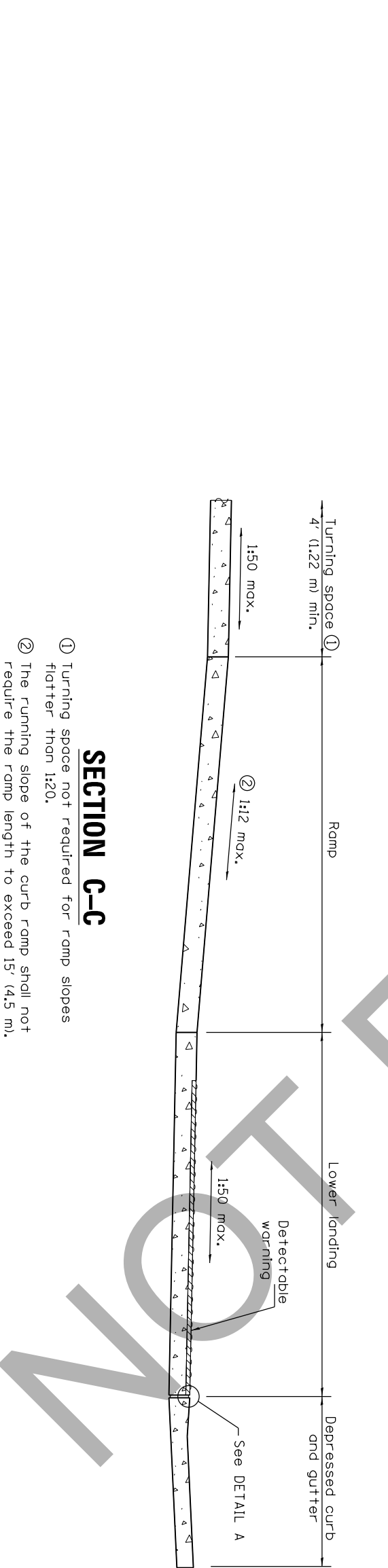

RAMP IN LANDSCAPED AREA
SETBACK > 5'

- SECTION C-C**
- ① Turning space not required for ramp slopes flatter than 1:20.
 - ② The running slope of the curb ramp shall not require the ramp length to exceed 15' (4.5 m).

GENERAL NOTES

All slope ratios are expressed as units of vertical displacement to units of horizontal displacement (V:H).

Where the turning space is constrained on a side opposite a ramp, the minimum length of the turning space in the direction of the ramp-run shall be 5' (1.52 m).

Where 1:50 maximum slope is shown, 1:64 is preferred.

See Standard 606001 for details of depressed curb adjacent to curb ramp.

All dimensions are in inches (millimeters) unless otherwise shown.

**PERPENDICULAR CURB RAMPS
FOR SIDEWALKS**

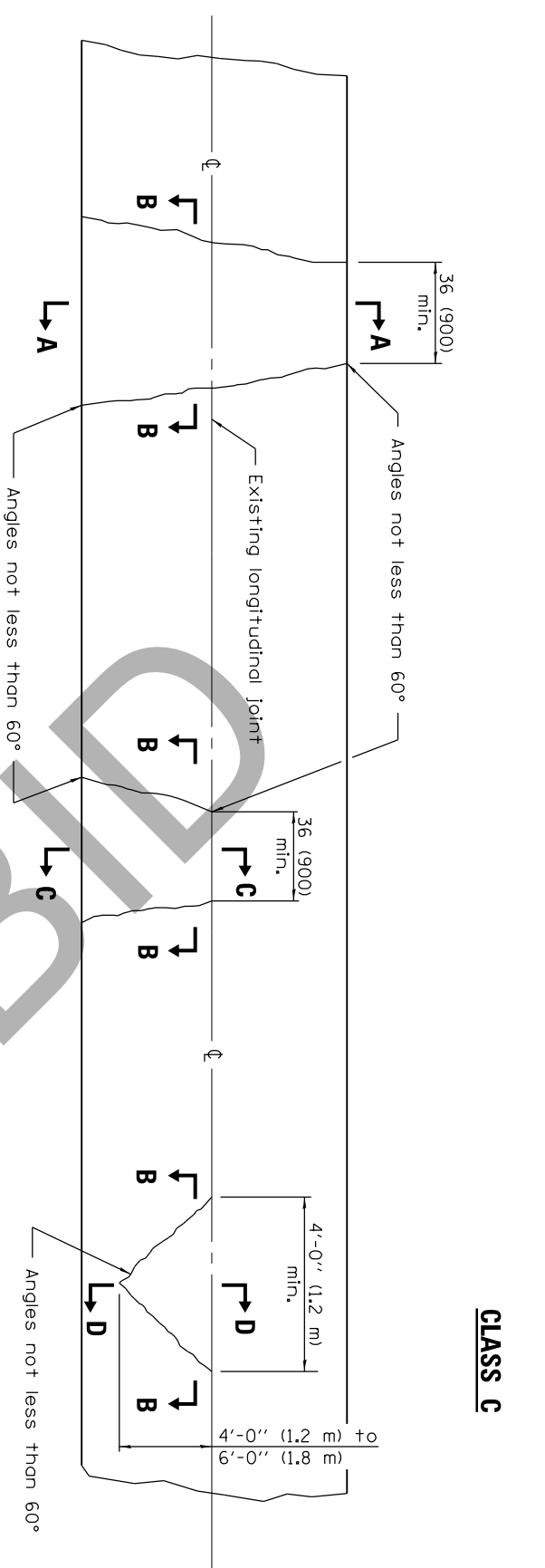

CLASS C

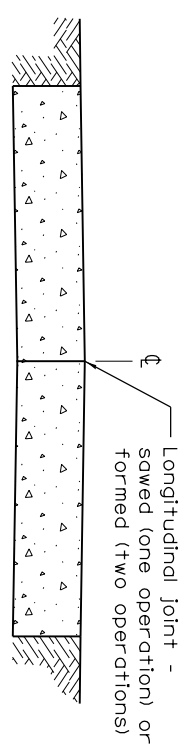

SECTION A-A

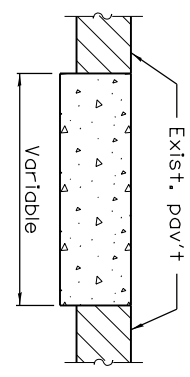

SECTION B-B

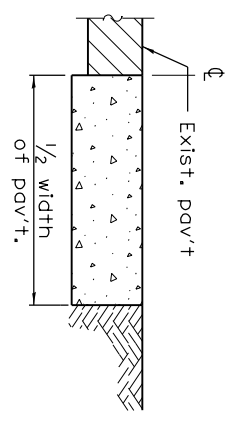

SECTION C-C

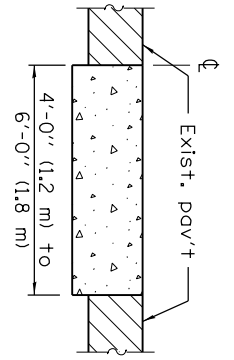

SECTION D-D

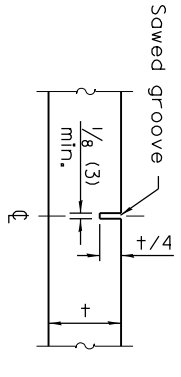

DETAIL OF SAWED CONTRACTION JOINT

Notes:
 Longitudinal joints shall be as detailed on Standard 420001, except the bars are not required for patches 20'-0" (6.0 m) or less in length.

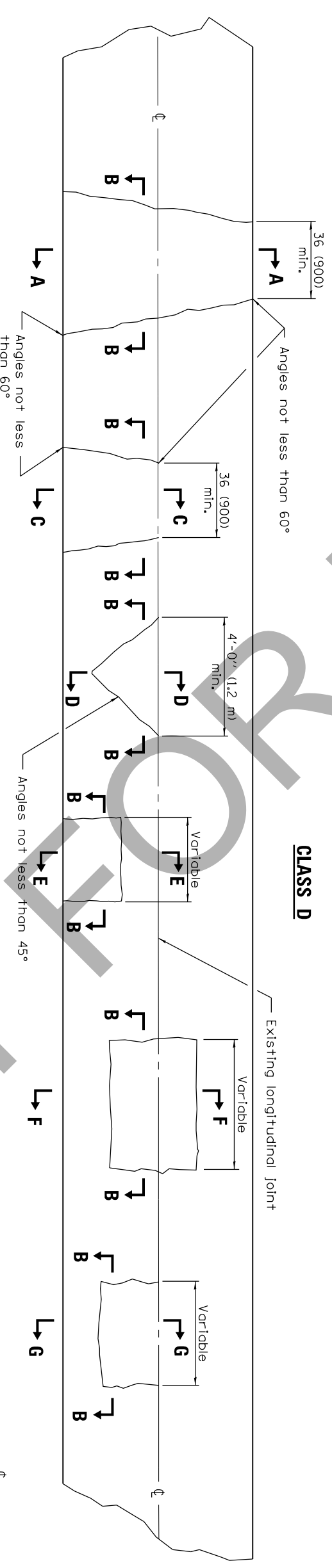

CLASS D

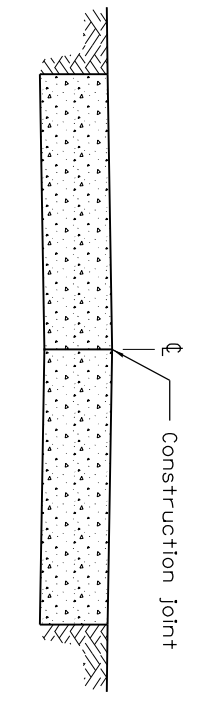

SECTION A-A

(Built in two operations)

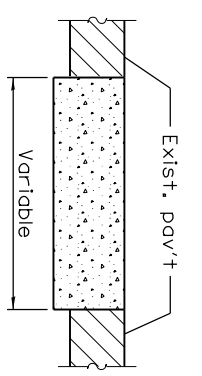

SECTION B-B

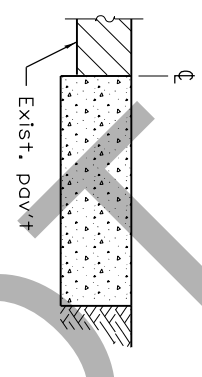

SECTION C-C

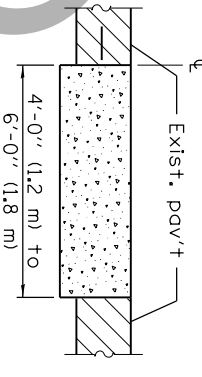

SECTION D-D

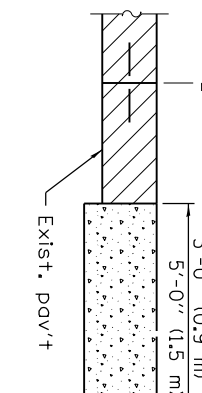

SECTION E-E

Construction joint

Exist. patch

Exist. patch

Exist. patch

GENERAL NOTES

Existing tie bars shall be either cut or removed.
 Marginal bars shall be cut.
 All dimensions are in inches (millimeters) unless otherwise shown.

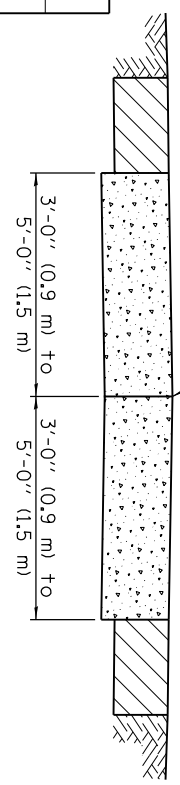

SECTION F-F

(Built in two operations)

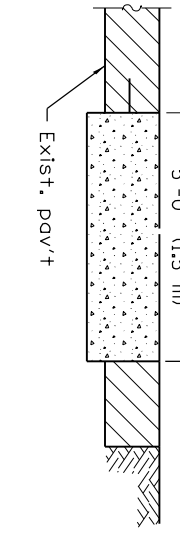

SECTION G-G

Illinois Department of Transportation
 PASSED January 1, 2008
 ENGINEER OF POLICY AND PROCEDURES
 APPROVED January 1, 2008
 ENGINEER OF DESIGN AND ENVIRONMENT

DATE	REVISIONS
1-1-08	Switched units to English (metric).
1-1-07	Revised Note for Class C patches.

CLASS C and D PATCHES

STANDARD 442201-03

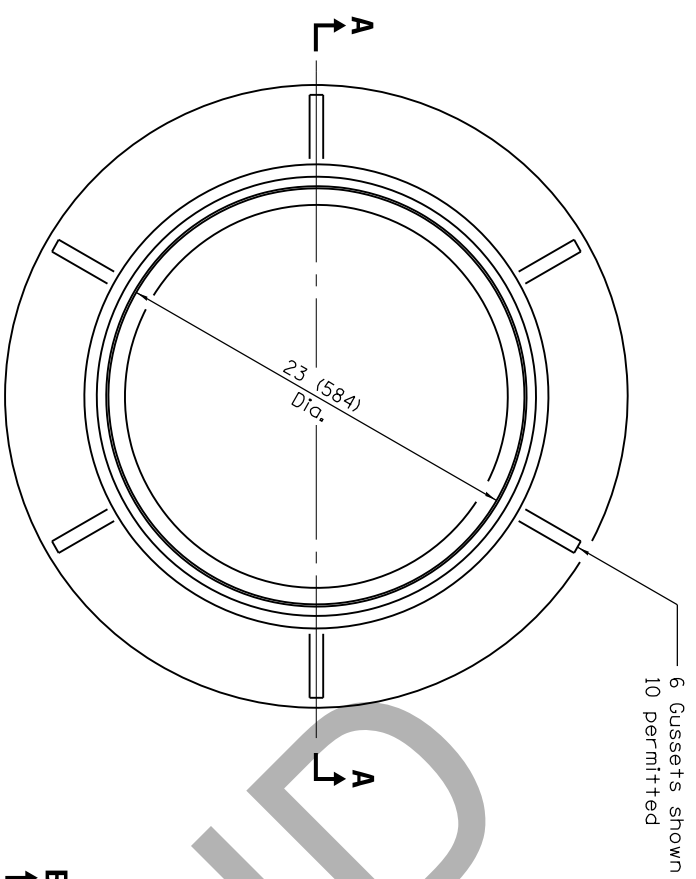

CAST FRAME

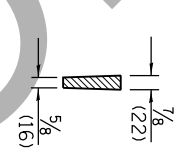
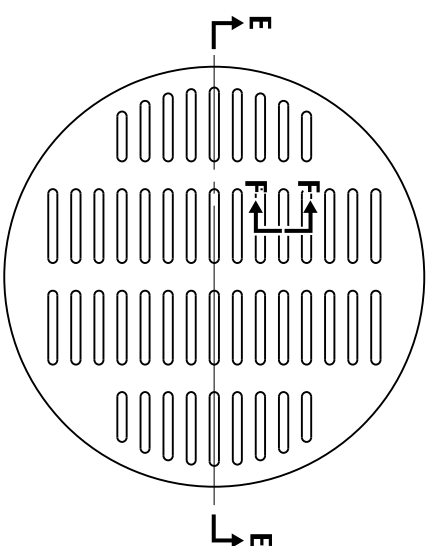
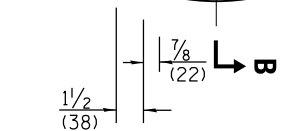
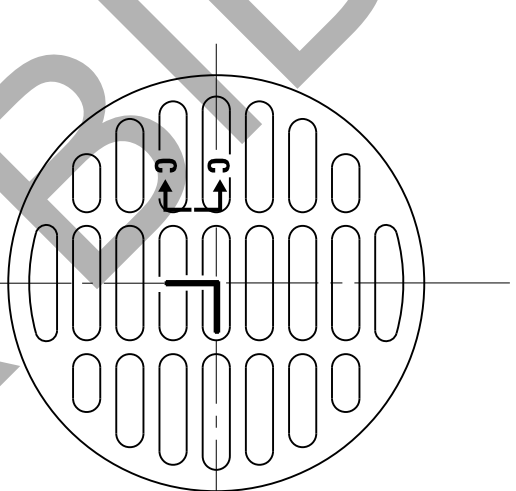

SECTION C-C

SECTION F-F

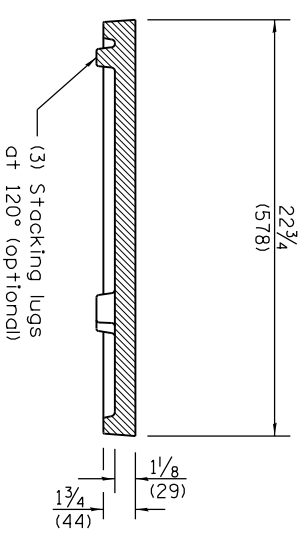
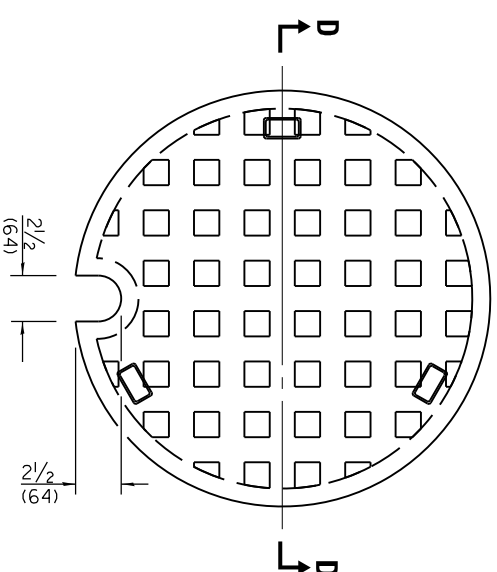

SECTION D-D

CAST CLOSED LID
Gray Iron Lid

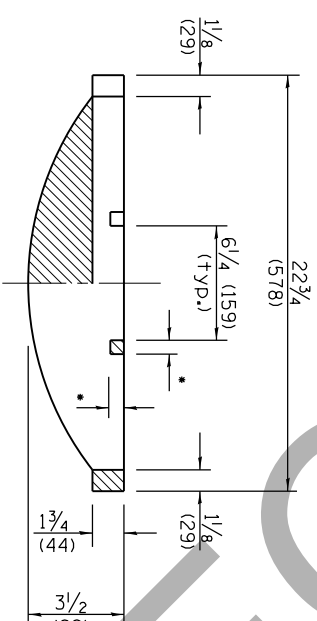

SECTION B-B

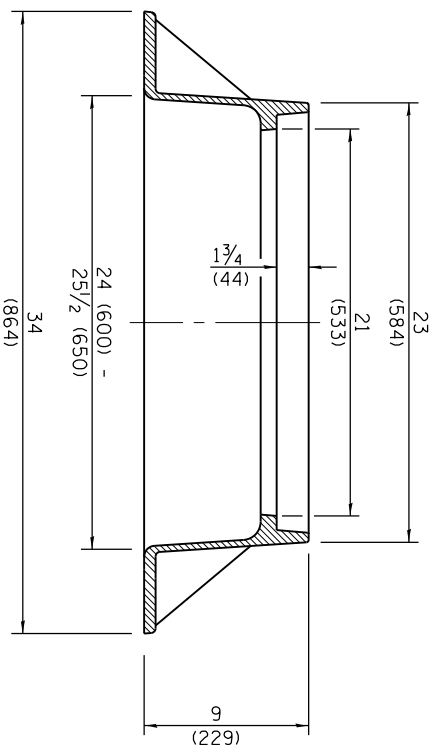

SECTION A-A
Gray Iron

• 3/4 (19) (typ.)

CAST OPEN LID

**ADA COMPLIANT
CAST OPEN LID**

All dimensions are in inches (millimeters) unless otherwise shown.

Illinois Department of Transportation

PASSED January 1, 2015
 ENGINEER OF POLICY AND PROCEDURES
 APPROVED January 1, 2015
 ENGINEER OF DESIGN AND ENVIRONMENT

DATE	REVISIONS
1-1-15	Revised dimensioning of frame. Added ADA compliant open lid.
1-1-09	Switched units to English (metric).

**FRAME AND LIDS
TYPE 1**

STANDARD 604001-04

Ø 5/8 (10) Dia. hole and 5/8x5/2 (16x140) slotted hole for galvanized 1/2 (M12) bolt, nut, and washer.

Curb box adjustable from 4 1/2 (115) to 9 (225)

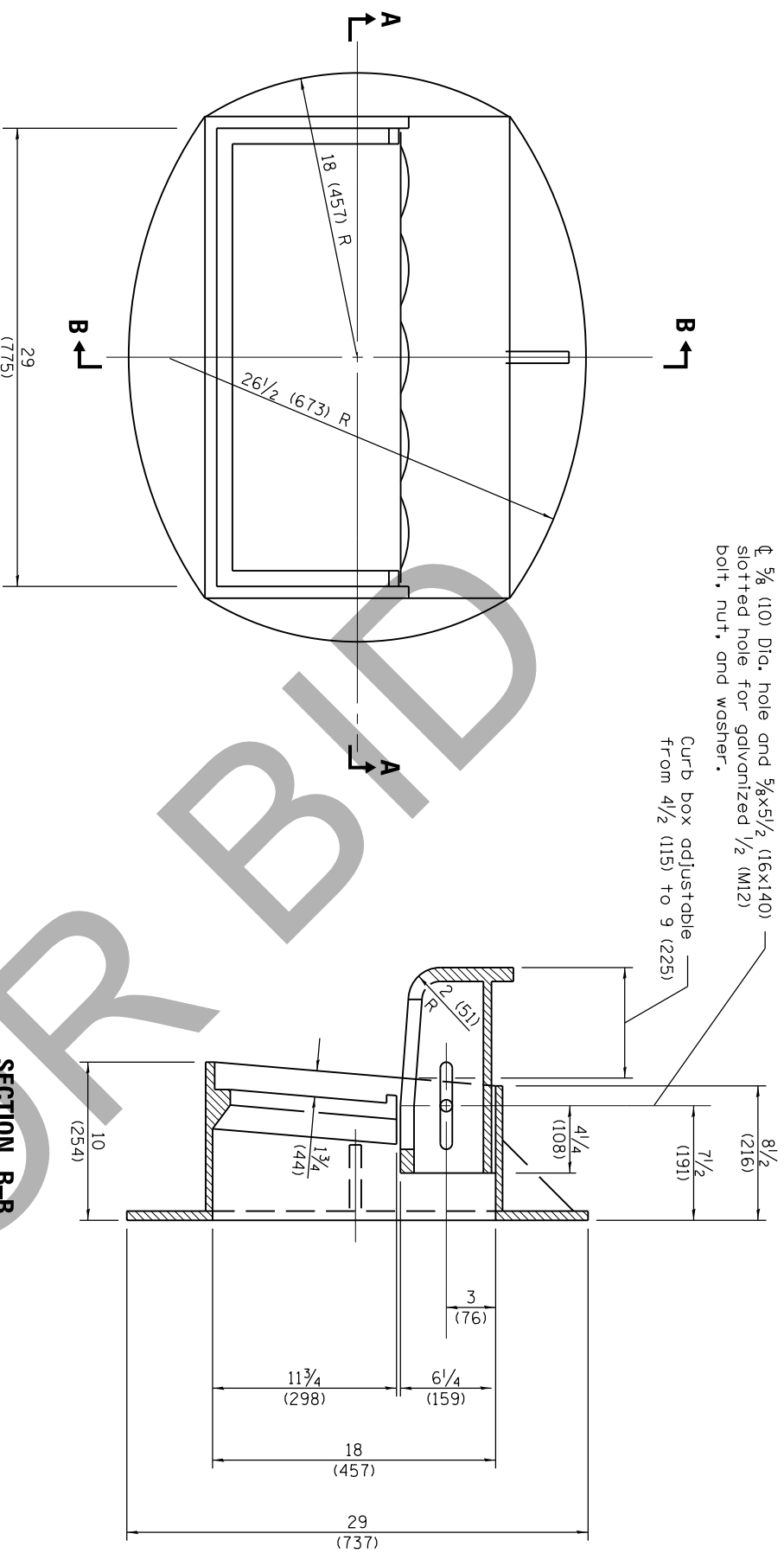

CAST FRAME

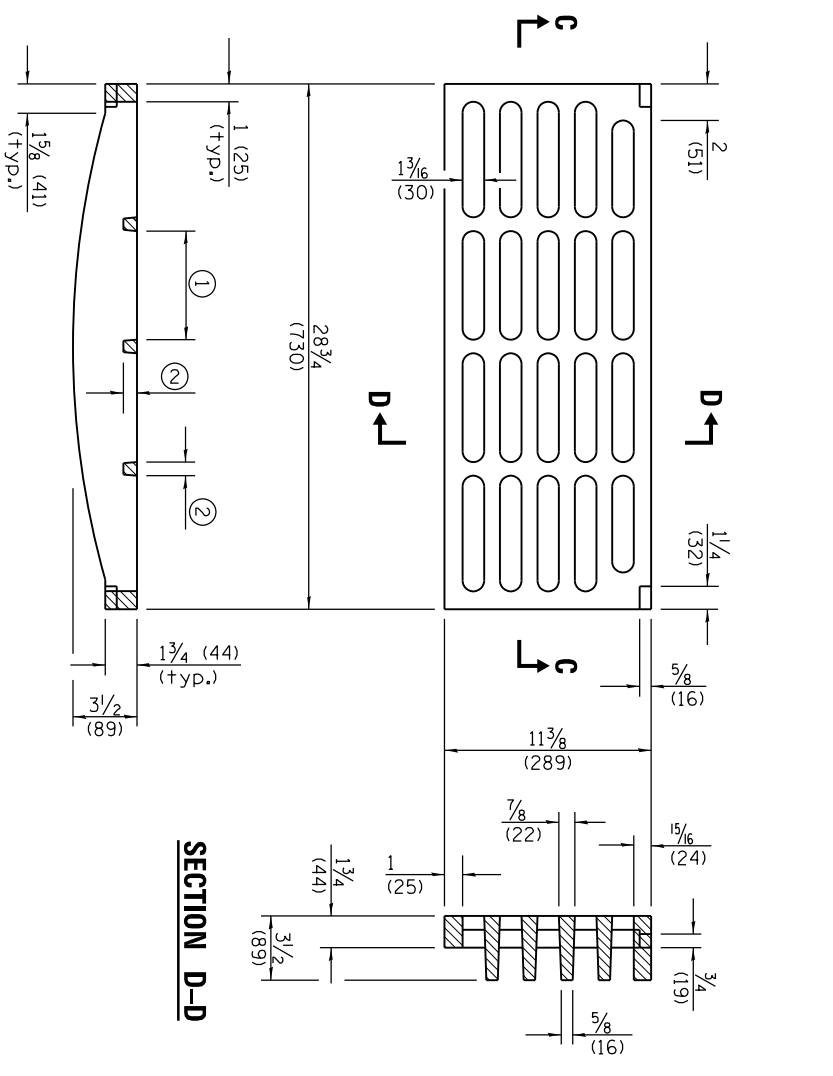

SECTION D-D

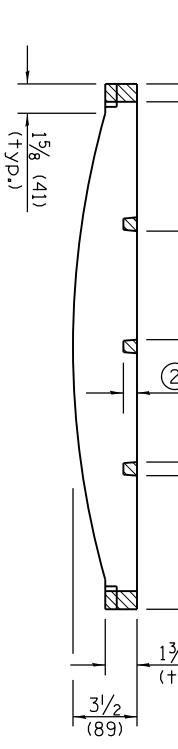

SECTION C-C

- ① = 6 1/4 (159) max. (typ.)
- ② = 3/4 (19) min. (typ.)

CAST GRATE

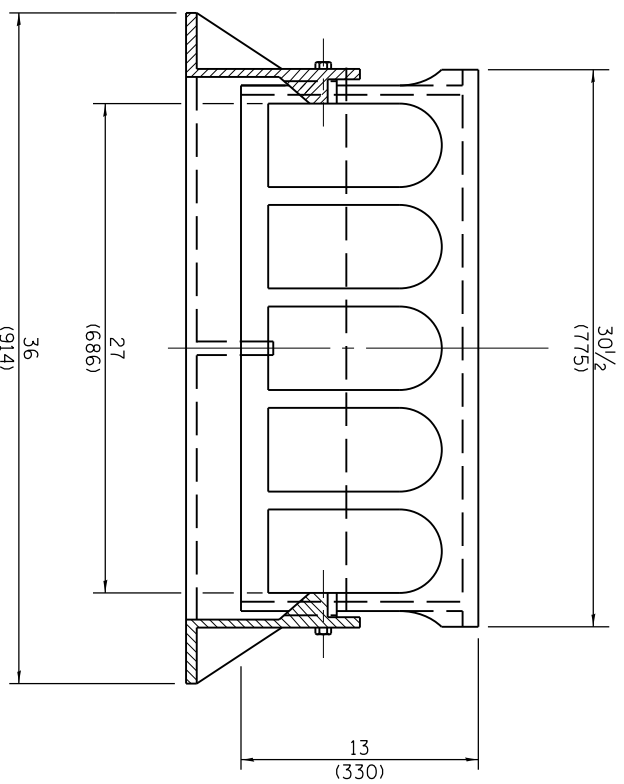

SECTION A-A

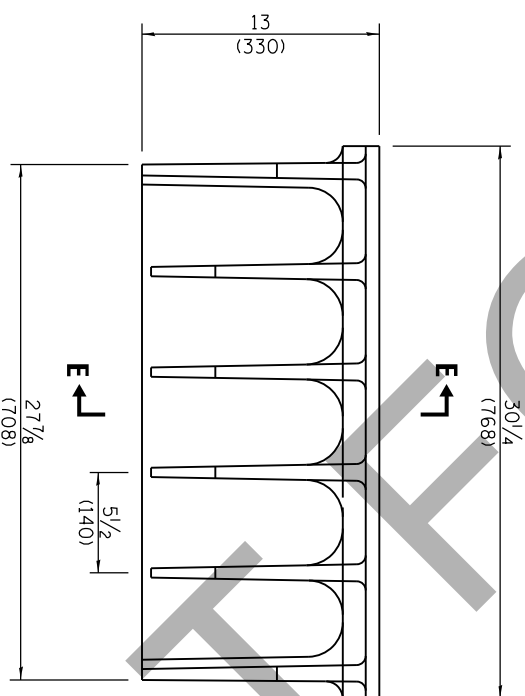

ALTERNATE CURB BOX

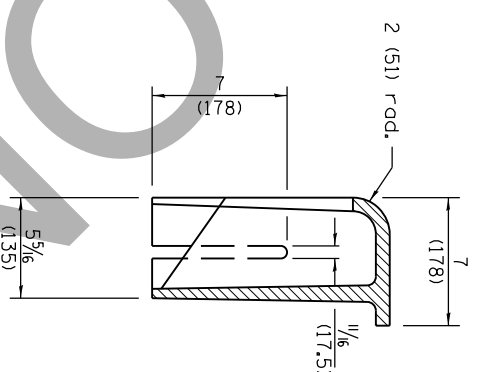

SECTION E-E

All dimensions are in inches (millimeters) unless otherwise shown.

Illinois Department of Transportation

PASSED January 1, 2015
 ENGINEER OF POLICY AND PROCEDURES
 APPROVED January 1, 2015
 ENGINEER OF DESIGN AND ENVIRONMENT

ISSUED 1-1-97

FRAME AND GRATE

TYPE 11

STANDARD 604051-04

REVISIONS

DATE	REVISIONS
1-1-15	Revised dimensions of frame and alternate curb box.
4-1-09	Switched units to English (metric).

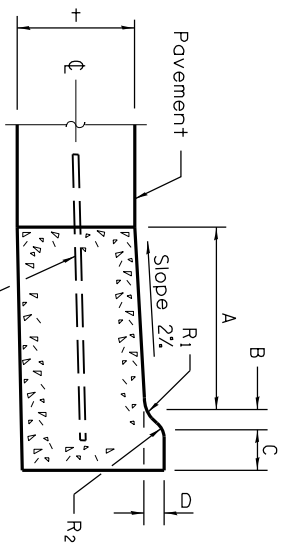
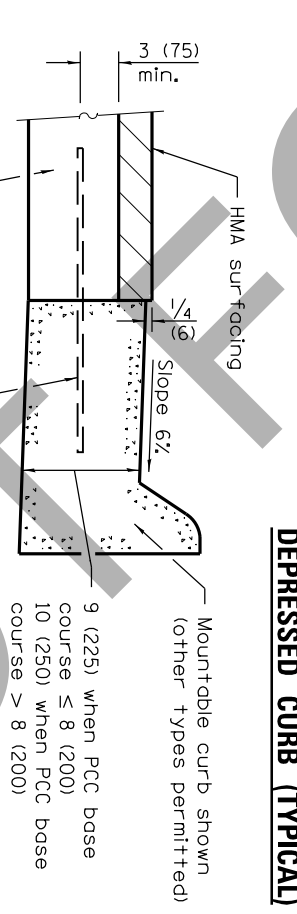
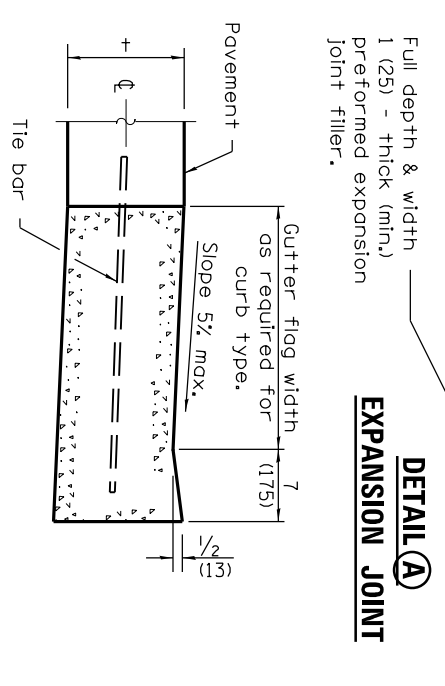
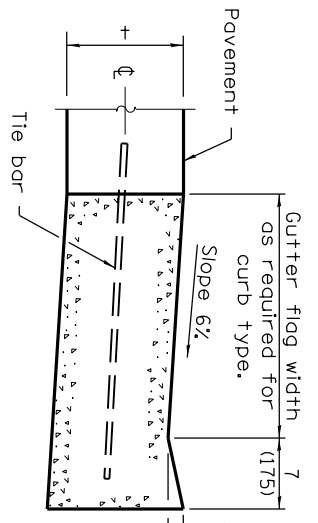
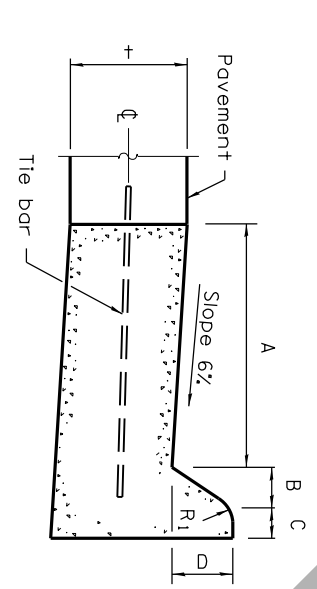
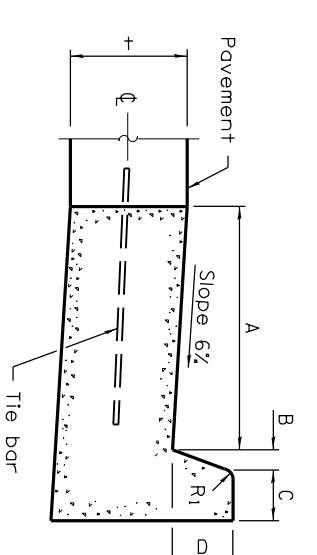
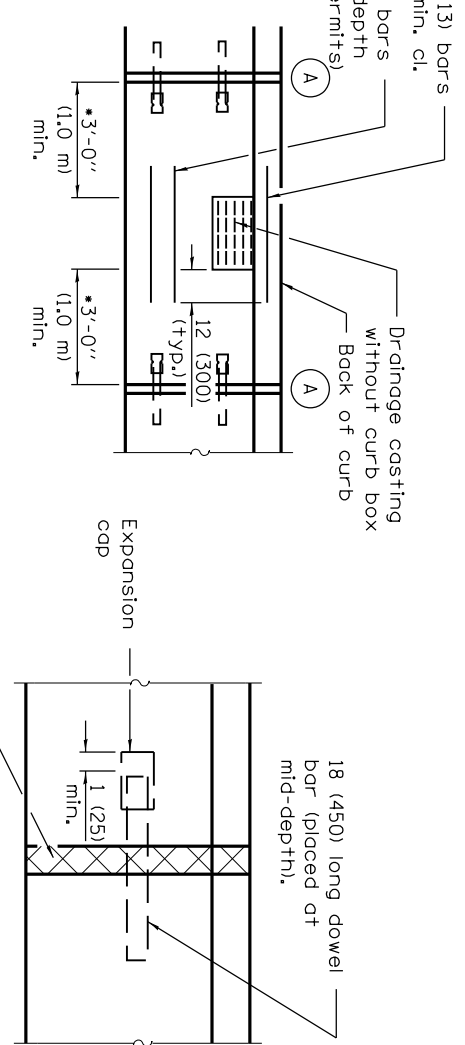
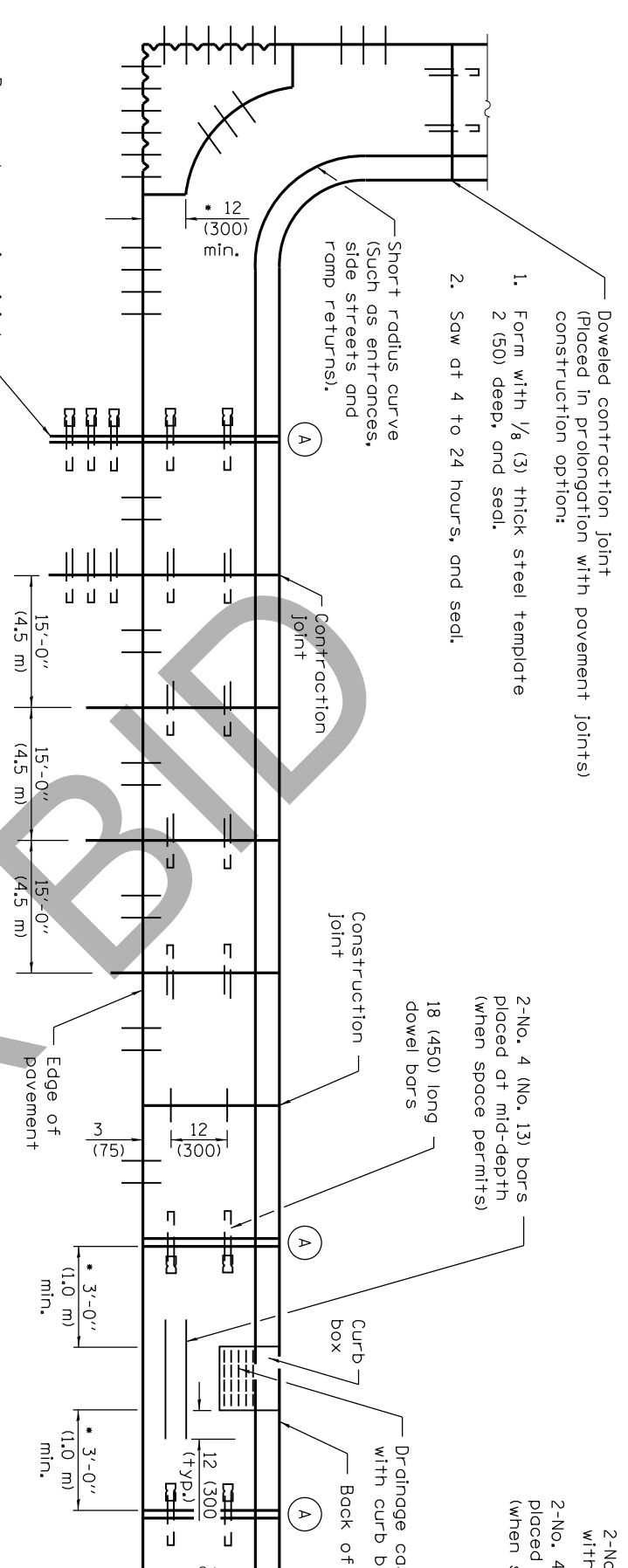

TABLE OF DIMENSIONS BARRIER CURB

TYPE	A	B	C	D	R ₁
B-6.06 *	6	1	6	6	1
(B-15.15)	(150)	(25)	(150)	(150)	(25)
B-6.12	12	1	6	6	1
(B-15.3)	(300)	(25)	(150)	(150)	(25)
B-6.18	18	1	6	6	1
(B-15.45)	(450)	(25)	(150)	(150)	(25)
B-6.24	24	1	6	6	1
(B-15.60)	(600)	(25)	(150)	(150)	(25)
B-9.12	12	2	5	9	1
(B-22.30)	(300)	(50)	(125)	(225)	(25)
B-9.18	18	2	5	9	1
(B-22.45)	(450)	(50)	(125)	(225)	(25)
B-9.24	24	2	5	9	1
(B-22.60)	(600)	(50)	(125)	(225)	(25)

TABLE OF DIMENSIONS MOUNTABLE CURB

TYPE	A	B	C	D	R ₁	R ₂
M-2.06	6	2	4	2	3	2
(M-5.15)	(150)	(50)	(100)	(50)	(75)	(50)
M-2.12	12	2	4	2	3	2
(M-5.30)	(300)	(50)	(100)	(50)	(75)	(50)
M-4.06	6	4	3	4	3	NA
(M-10.15)	(150)	(100)	(75)	(100)	(75)	NA
M-4.12	12	4	3	4	3	NA
(M-10.30)	(300)	(100)	(75)	(100)	(75)	NA
M-4.18	18	4	3	4	3	NA
(M-10.45)	(450)	(100)	(75)	(100)	(75)	NA
M-4.24	24	4	3	4	3	NA
(M-10.60)	(600)	(100)	(75)	(100)	(75)	NA
M-6.06	6	6	2	6	2	NA
(M-15.15)	(150)	(150)	(50)	(150)	(50)	NA
M-6.12	12	6	2	6	2	NA
(M-15.30)	(300)	(150)	(50)	(150)	(50)	NA
M-6.18	18	6	2	6	2	NA
(M-15.45)	(450)	(150)	(50)	(150)	(50)	NA
M-6.24	24	6	2	6	2	NA
(M-15.60)	(600)	(150)	(50)	(150)	(50)	NA

GENERAL NOTES

The bottom slope of combination curb and gutter constructed adjacent to pcc pavement shall be the same slope as the subbase or 6% when subbase is omitted.

+ = Thickness of pavement.

Longitudinal joint tie bars shall be No. 6 (No. 19) at 24 (600) centers in accordance with details for longitudinal construction joint shown on Standard 420001.

A minimum clearance of 2 (50) between the end of the tie bar and the back of the curb shall be maintained.

The dowel bars shown in contraction joints will only be required for monolithic construction.

See Standard 606301 for details of corner islands.

All dimensions are in inches (millimeters) unless otherwise shown.

Illinois Department of Transportation

PASSED January 1, 2015
 Michael R. Bond
 ENGINEER OF POLICY AND PROCEDURES
 APPROVED January 1, 2015
 ENGINEER OF DESIGN AND ENVIRONMENT

REVISIONS

DATE	REVISIONS
1-1-15	Added B-6.06 (B-15.15) barrier curb and gutter to table (corner islands only).
1-1-13	Added general note regarding requirement for dowel bars.

CONCRETE CURB TYPE B AND COMBINATION CONCRETE CURB AND GUTTER
 (Sheet 1 of 2)

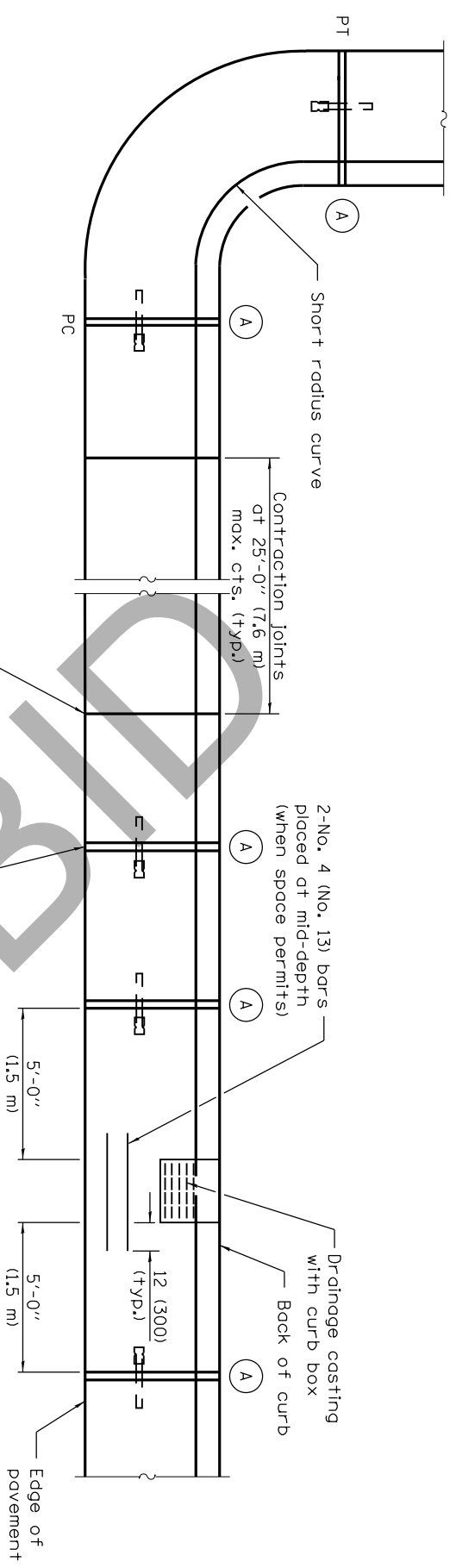

- Undoweled contraction joint (typ.) construction options:
1. Form with 1/8 (3) thick steel template 2 (50) deep, and seal.
 2. Saw 2 (50) deep at 4 to 24 hours, and seal.
 3. Insert 3/4 (20) thick preformed joint filler full depth and width.

PLAN

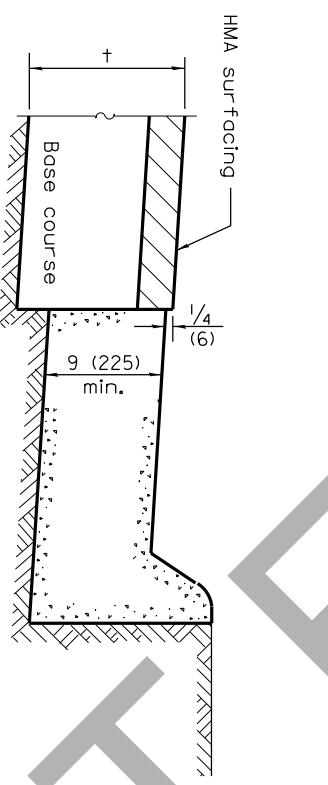
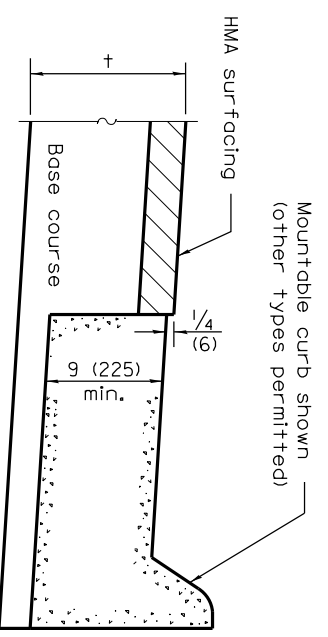

ON DISTURBED SUBGRADE

ON UNDISTURBED SUBGRADE

ADJACENT TO FLEXIBLE PAVEMENT

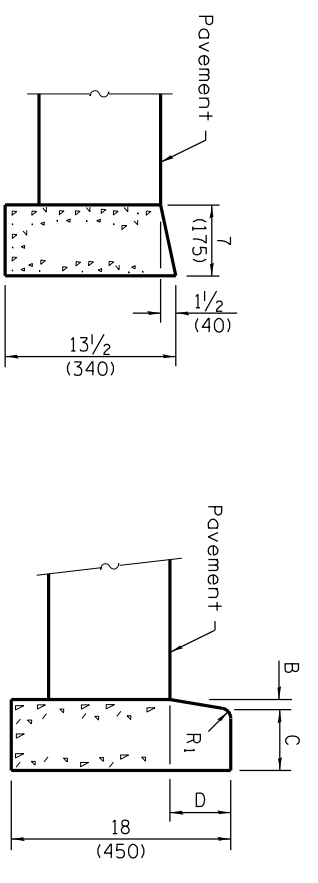

DEPRESSED CURB

BARRIER CURB

ADJACENT TO FLEXIBLE PAVEMENT

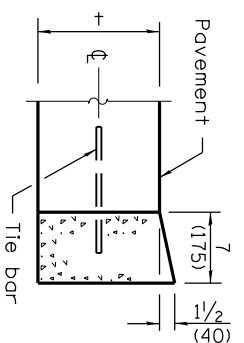

DEPRESSED CURB

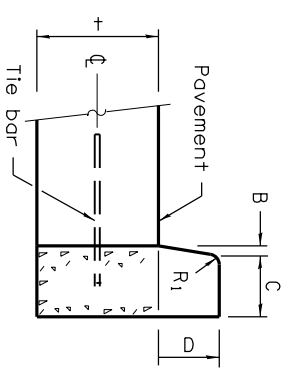

BARRIER CURB

ADJACENT TO PCC PAVEMENT OR PCC BASE COURSE

CONCRETE CURB TYPE B

CONCRETE CURB TYPE B AND COMBINATION CONCRETE CURB AND GUTTER

Illinois Department of Transportation
 PASSED January 1, 2015
 ENGINEER OF POLICY AND PROCEDURES
 APPROVED January 1, 2015
 ISSUED 1-1-97

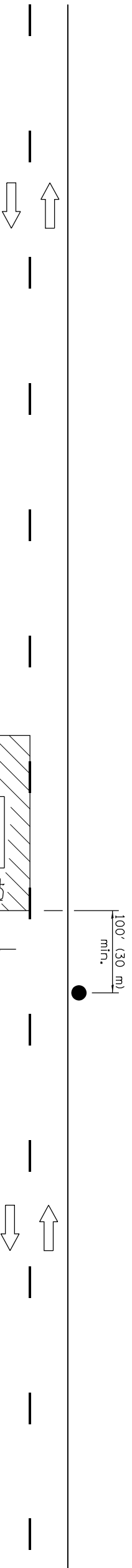

For any operation that encroaches in the area between the centerline and a line 24 (600) outside the edge of the pavement for a period of less than 15 minutes.

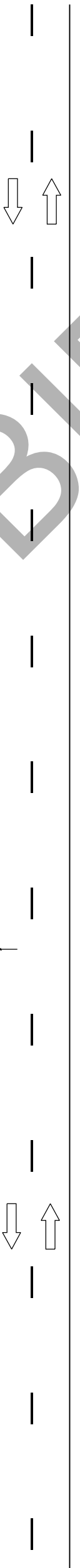

For any operation that is more than 24 (600) outside the edge of the pavement for a period of less than 60 minutes.

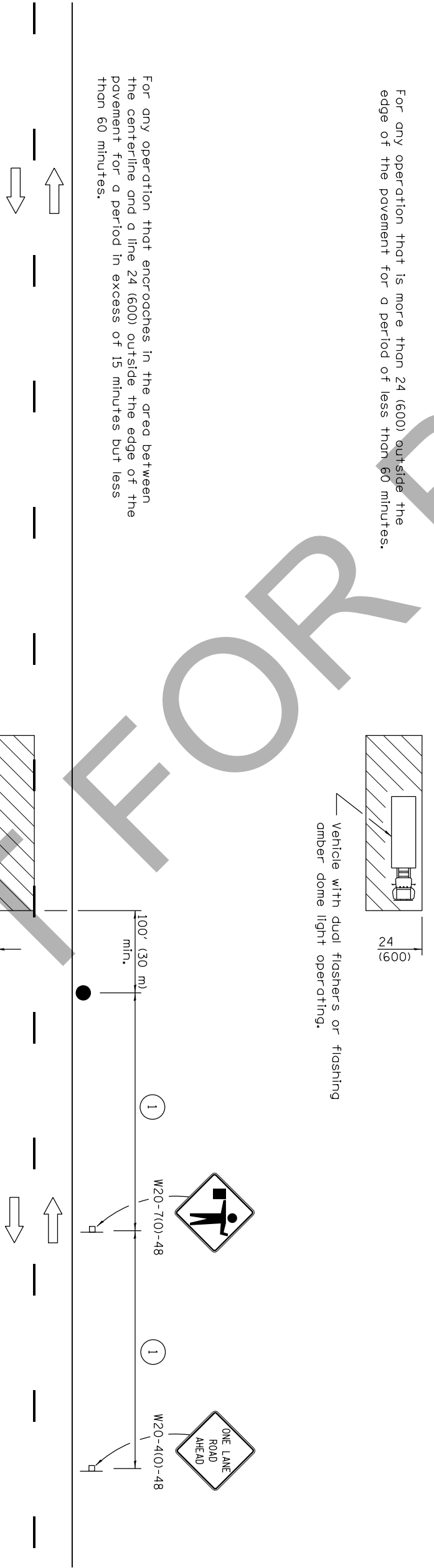

For any operation that encroaches in the area between the centerline and a line 24 (600) outside the edge of the pavement for a period in excess of 15 minutes but less than 60 minutes.

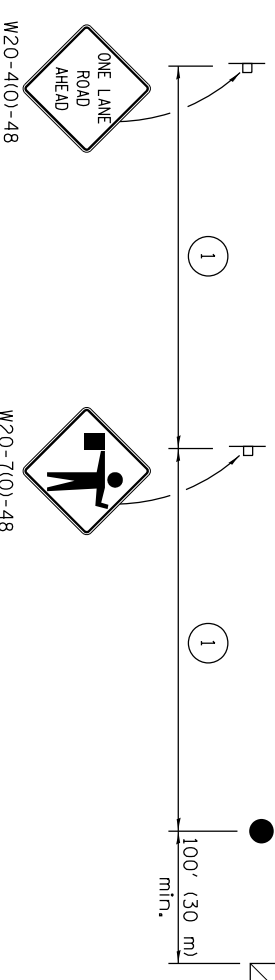

SIGN SPACING	
Posted Speed	Sign Spacing
55	500' (150 m)
50-45	350' (100 m)
<45	200' (60 m)

① = Refer to SIGN SPACING table for distances.

All dimensions are in inches (millimeters) unless otherwise shown.

TYPICAL APPLICATIONS

- Marking patches
- Field survey
- String line
- Utility operations
- Cleaning up debris on pavement

SYMBOLS

- Work area
- Sign on portable or permanent support
- Flagger with traffic control sign

Illinois Department of Transportation

APPROVED January 1, 2011
 ENGINEER OF SAFETY ENGINEERING
 APPROVED January 1, 2011
 ENGINEER OF DESIGN AND ENVIRONMENT

ISSUED 1-1-97

DATE	REVISIONS
1-1-11	Revised flagger sign.
1-1-09	Switched units to English (metric).

LANE CLOSURE, 2L, 2W, SHORT TIME OPERATIONS

STANDARD 701301-04

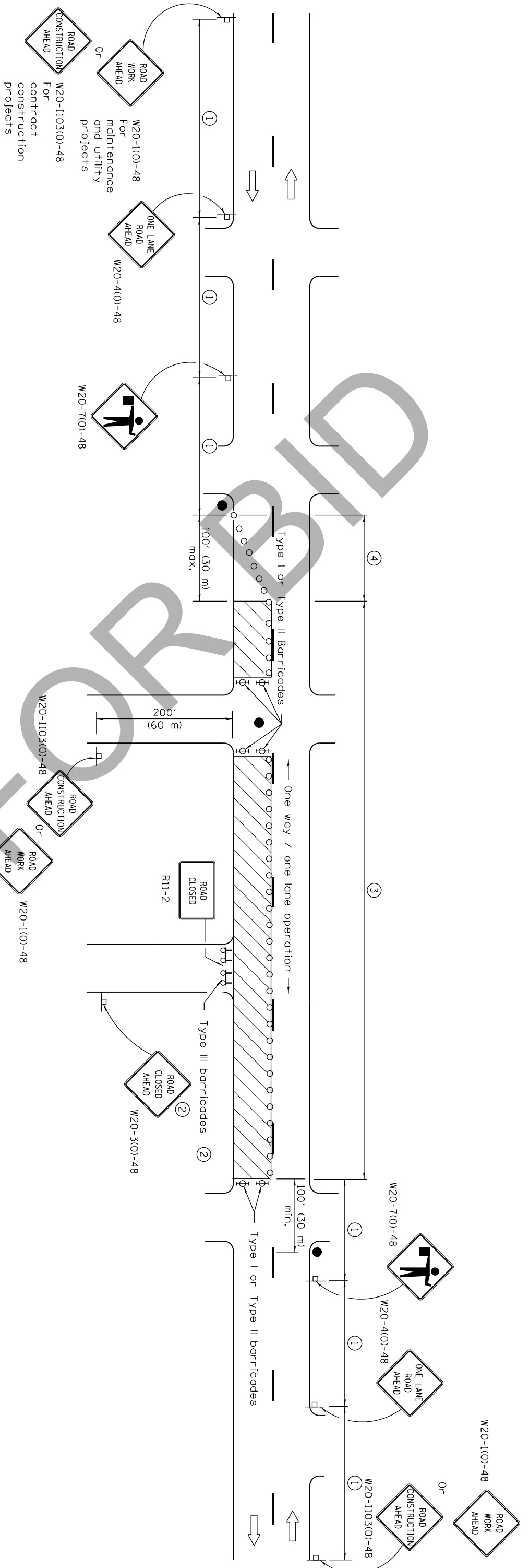

SIGN SPACING	
Posted Speed	Sign Spacing
55	500' (150 m)
50-45	350' (100 m)
<45	200' (60 m)

SYMBOLS

- ▨ Work area
- Cone, drum or barricade (not required for moving operations)
- ⊥ Sign on portable or permanent support
- Flagger with traffic control sign
- ⊕ Barricade or drum with flashing light
- ⊕ Type III barricade with flashing lights

- ① Refer to SIGN SPACING TABLE for distances.
- ② For approved sideroad closures.
- ③ Cones at 25' (8 m) centers for 250' (75 m). Additional cones may be placed at 50' (15 m) centers. When drums or Type I or Type II barricades are used, the interval between devices may be doubled.
- ④ Cones, drums or barricades at 20' (6 m) centers.

GENERAL NOTES

This Standard is used where at any time, day or night, any vehicle, equipment, workers or their activities on the pavement requiring the closure of one traffic lane in an urban area. All dimensions are in inches (millimeters) unless otherwise shown.

Illinois Department of Transportation

APPROVED January 1, 2011
 ENGINEER OF SAFETY ENGINEERING
 APPROVED January 1, 2011
 ENGINEER OF DESIGN AND ENVIRONMENT

ISSUED 1-1-97

DATE	REVISIONS
1-1-11	Revised flagger sign.
1-1-09	Switched units to English (metric).
	Corrected sign No.'s.

**URBAN LANE CLOSURE,
2L, 2W, UNDIVIDED**

STANDARD 701501-06

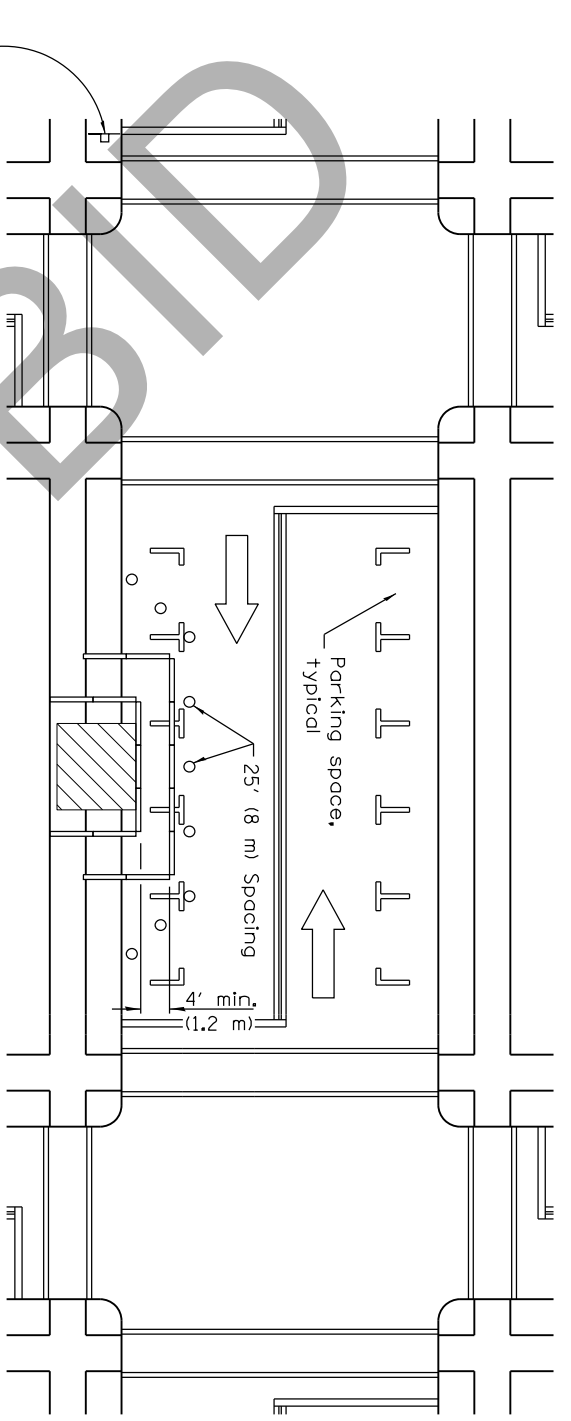

① ROAD CONSTRUCTION AHEAD
W20-1103(O)-48 for construct construction projects

OR
① ROAD WORK AHEAD
W20-1101-48 for maintenance and utility projects

SIDEWALK DIVERSION

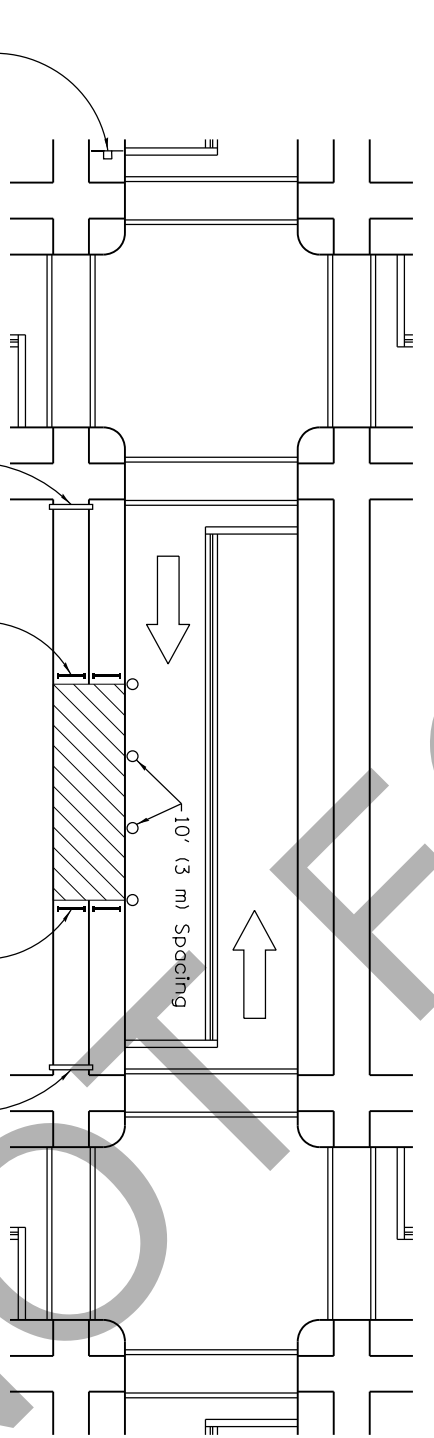

① ROAD CONSTRUCTION AHEAD
W20-1103(O)-48 for construct construction projects

OR
① ROAD WORK AHEAD
W20-1101-48 for maintenance and utility projects

R11-1101-2418
SIDEWALK CLOSED

R11-1102-2430
SIDEWALK CLOSED USE OTHER SIDE

SIDEWALK CLOSURE

① Omit whenever duplicated by road work traffic control.

GENERAL NOTES

This Standard is used where, at any time, pedestrian traffic must be rerouted due to work being performed.
This Standard must be used in conjunction with other Traffic Control & Protection Standards when roadway traffic is affected.
Temporary facilities shall be detectable and accessible.
The temporary pedestrian facilities shall be provided on the same side of the closed facilities whenever possible.
The SIDEWALK CLOSED / USE OTHER SIDE sign shall be placed at the nearest crosswalk or intersection to each end of the closure. Where the closure occurs at a corner, the signs shall be erected on the corners across the street from the closure. The SIDEWALK CLOSED signs shall be used at the ends of the actual closures.
Type III barricades and R11-2-4830 signs shall be positioned as shown in "ROAD CLOSED TO ALL TRAFFIC" detail on Standard 701901.
All dimensions are in inches (millimeters) unless otherwise shown.

SYMBOLS

- Work area
- Sign on portable or permanent support
- Barricade or drum
- Cone, drum or barricade
- Type III barricade
- Detectable pedestrian channelizing barricade

Illinois Department of Transportation

APPROVED April 1, 2016
ENGINEER OF SAFETY ENGINEERING

APPROVED April 1, 2016
ENGINEER OF DESIGN AND ENVIRONMENT

ISSUED 1-1-97

DATE	REVISIONS
4-1-16	Omitted orange safety fence from standard as this is covered in the std. spec.
1-1-12	Added SIDEWALK DIVERSION. Modified appearance of plan views. Renamed Std.

SIDEWALK, CORNER OR CROSSWALK CLOSURE

(Sheet 1 of 2)

STANDARD 701801-06

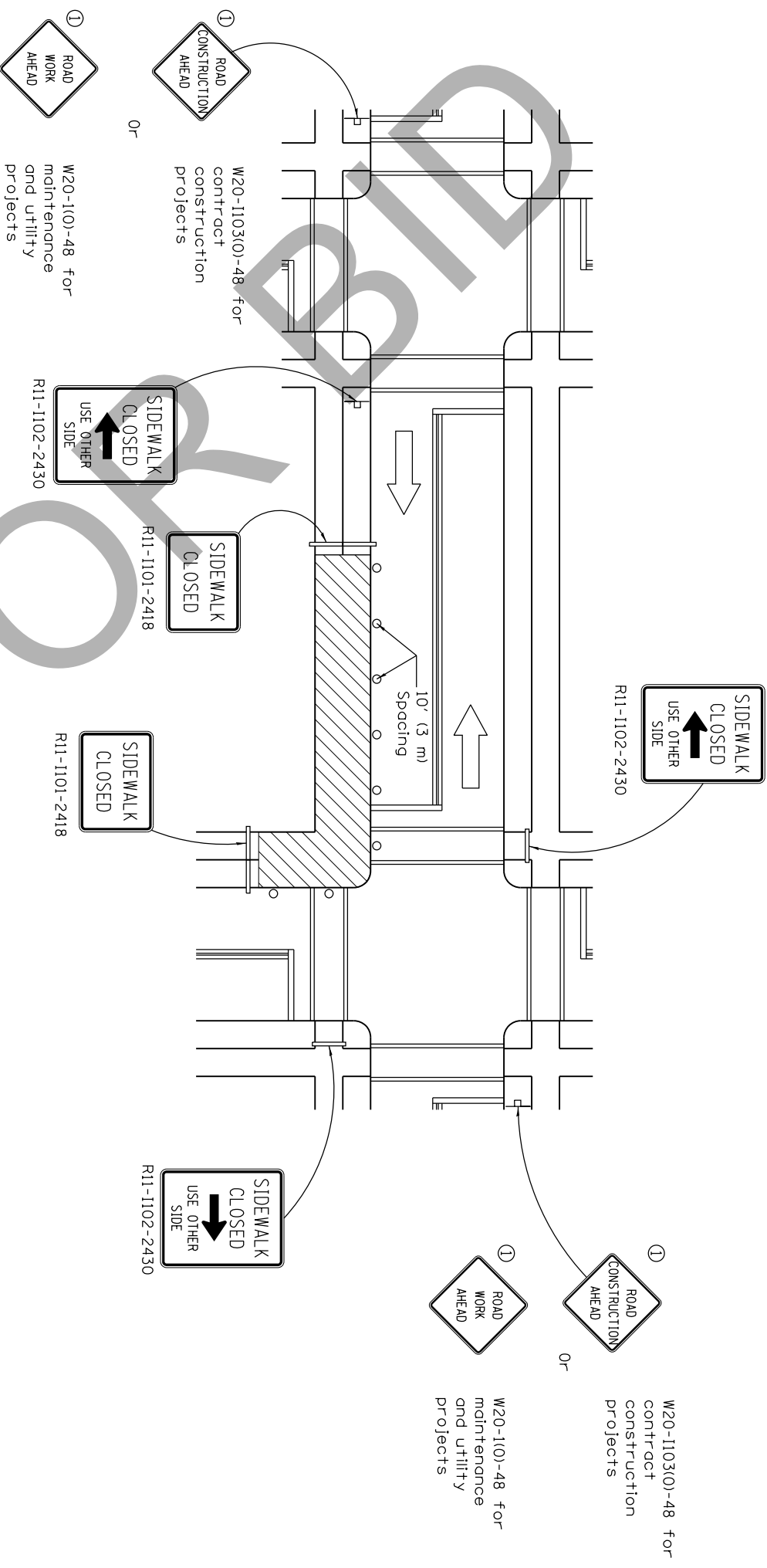

CORNER CLOSURE

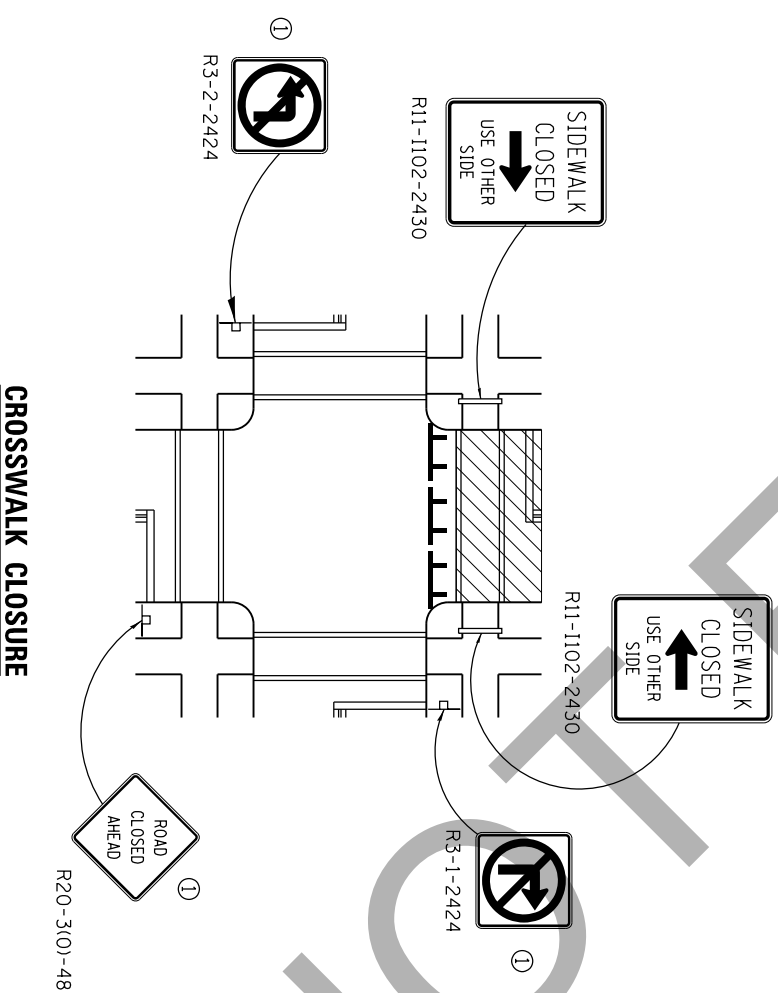

CROSSWALK CLOSURE

SIDEWALK, CORNER OR CROSSWALK CLOSURE

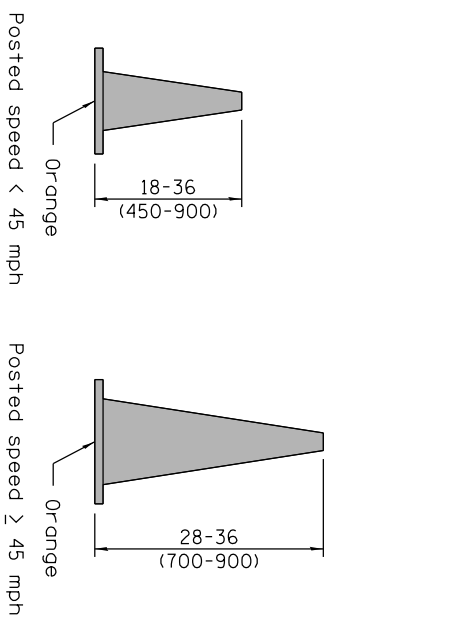

CONE FOR DAYTIME

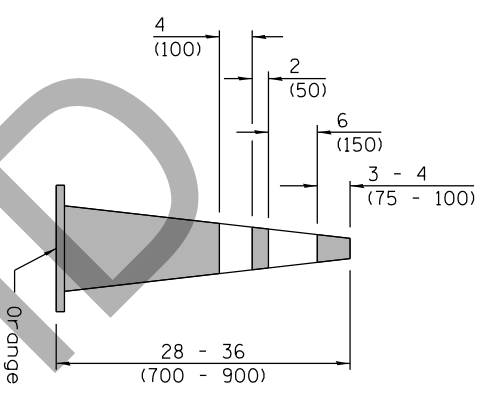

REFLECTORIZED CONE FOR NIGHTTIME

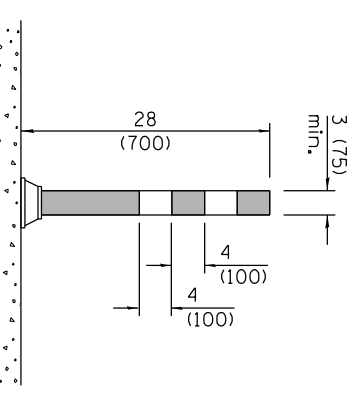

FLEXIBLE DELINEATOR

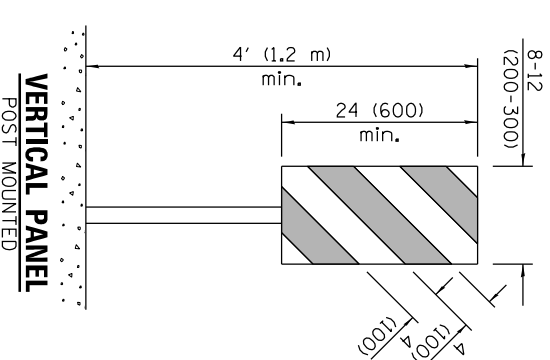

VERTICAL PANEL POST MOUNTED

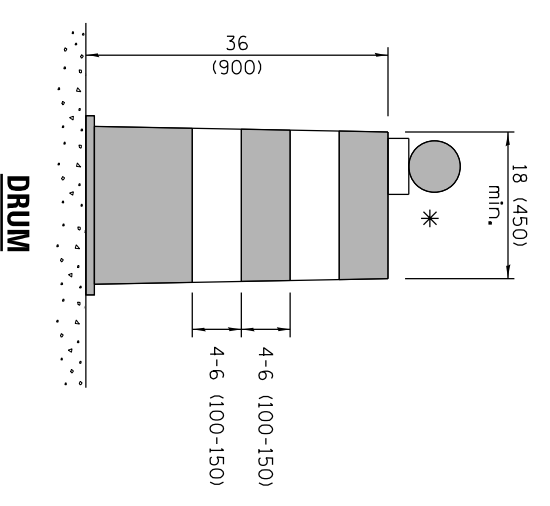

DRUM

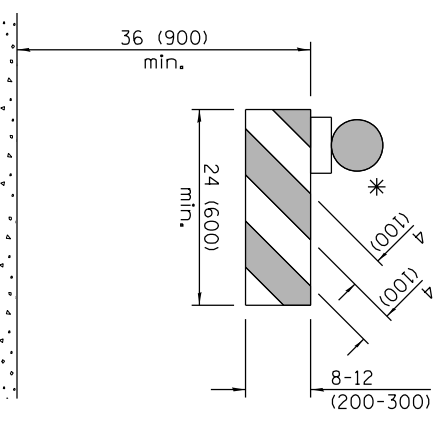

TYPE I BARRICADE

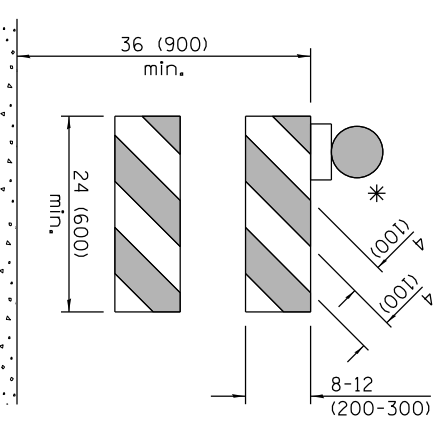

TYPE II BARRICADE

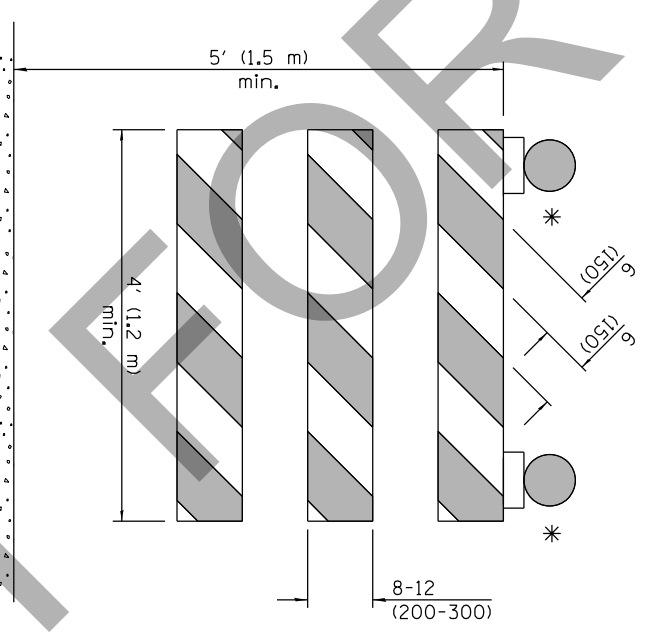

TYPE III BARRICADE

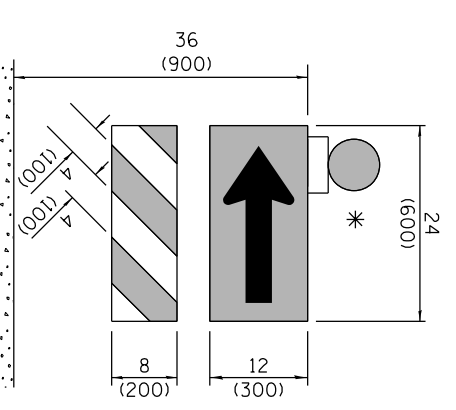

DIRECTION INDICATOR BARRICADE

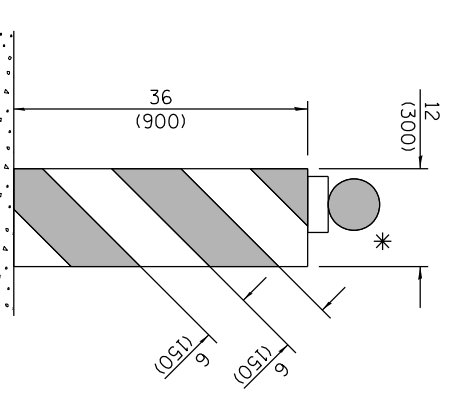

VERTICAL BARRICADE

* Warning lights (if required)

GENERAL NOTES
All heights shown shall be measured above the pavement surface.
All dimensions are in inches (millimeters) unless otherwise shown.

Illinois Department of Transportation
APPROVED Apr 11, 2016
ENGINEER OF OPERATIONS
APPROVED Apr 11, 2016
ENGINEER OF DESIGN AND ENVIRONMENT

ISSUED 1-1-97

DATE	REVISIONS
4-1-16	Add dim's to barricades, Rev. note for post mnt. signs.
1-1-15	Rev. cone dtls. Add W12-1103. Revised two sign numbers on sheet 2. Added note req. PHOTO ENFORCED plaque.

TRAFFIC CONTROL DEVICES

STANDARD 701901-05

(Sheet 1 of 3)

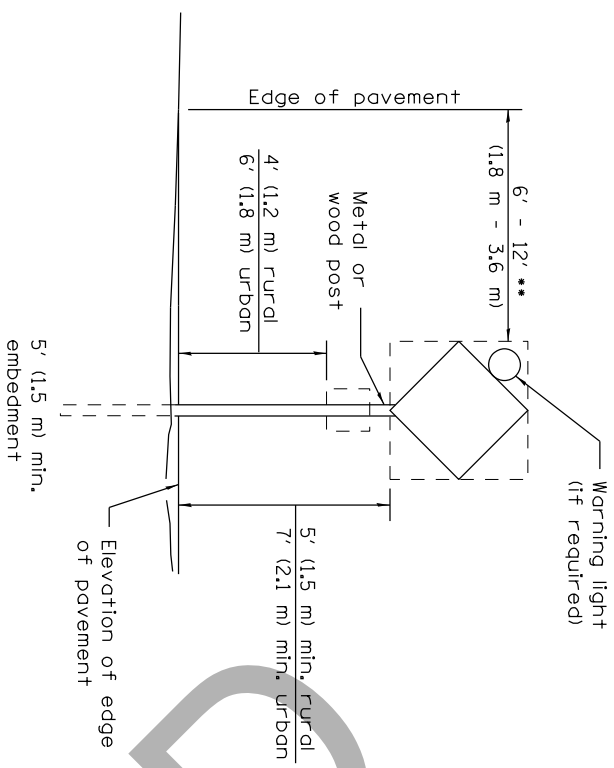

POST MOUNTED SIGNS

•• When curb or paved shoulder are present this dimension shall be 24 (600) to the face of curb or 6' (1.8 m) to the outside edge of the paved shoulder.

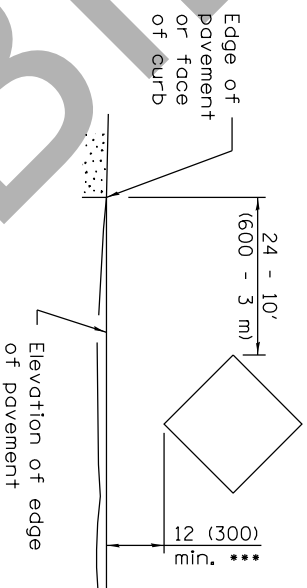

SIGNS ON TEMPORARY SUPPORTS

••• When work operations exceed four days, this dimension shall be 5' (1.5 m) min. If located behind other devices, the height shall be sufficient to be seen completely above the devices.

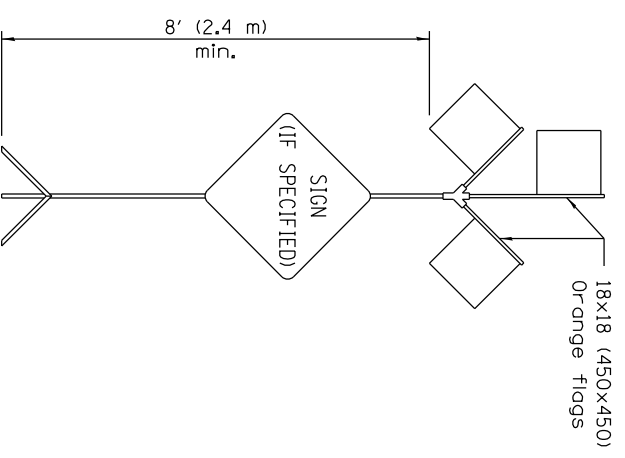

HIGH LEVEL WARNING DEVICE

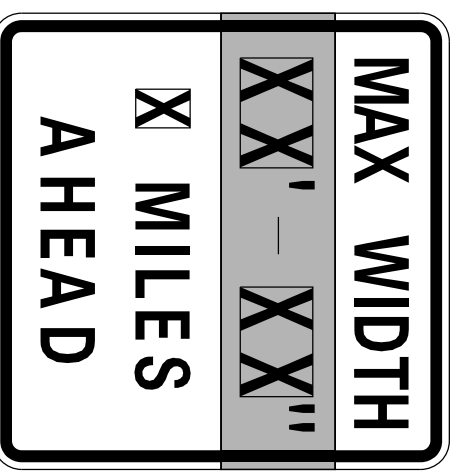

W12-1103-4848

WIDTH RESTRICTION SIGN

XX'-XX" width and X miles are variable.

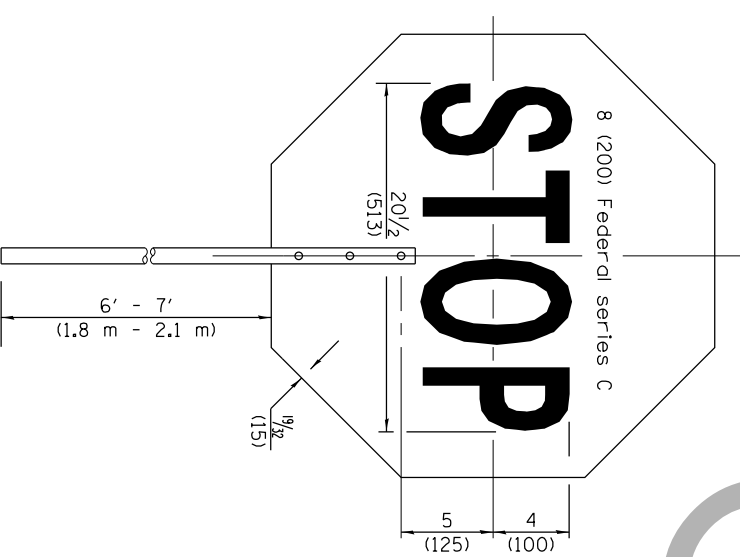

FRONT SIDE

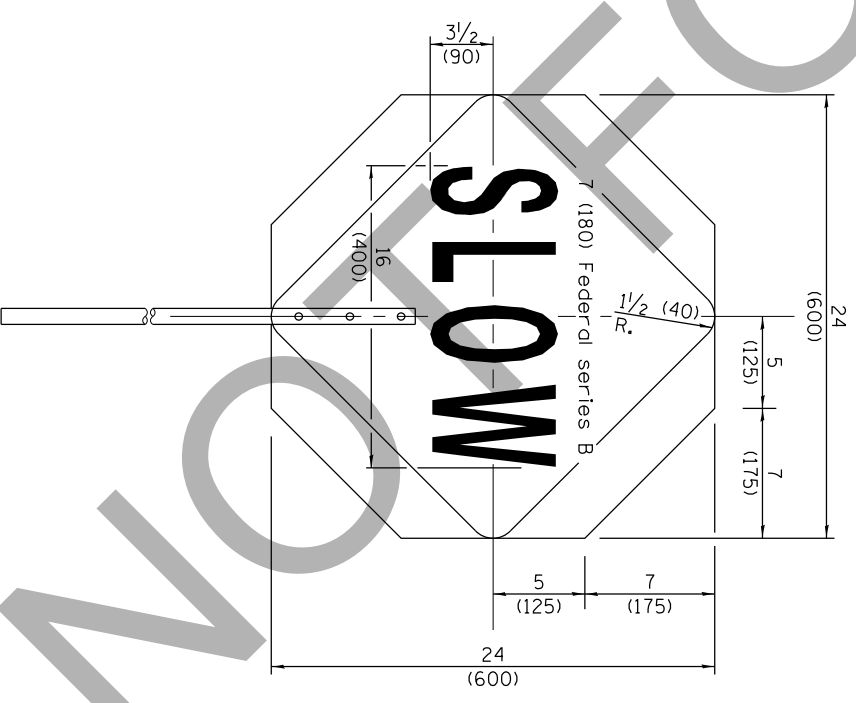

REVERSE SIDE

FLAGGER TRAFFIC CONTROL SIGN

ROAD CONSTRUCTION NEXT X MILES

G20-110410-6036

END CONSTRUCTION

G20-110510-6024

This signing is required for all projects 2 miles (3200 m) or more in length.
 ROAD CONSTRUCTION NEXT X MILES sign shall be placed 500' (150 m) in advance of project limits.
 END CONSTRUCTION sign shall be erected at the end of the job unless another job is within 2 miles (3200 m).
 Dual sign displays shall be utilized on multi-lane highways.

WORK LIMIT SIGNING

WORK ZONE	W21-111510-3618
SPEED LIMIT	R2-1-3648
PHOTO ENFORCED	R10-1108p-3618 ••••
XXXX FINE MINIMUM	R2-1106p-3618

Sign assembly as shown on Standards or as allowed by District Operations.

END WORK ZONE SPEED LIMIT	G20-110310-6036
---------------------------	-----------------

This sign shall be used when the above sign assembly is used.

HIGHWAY CONSTRUCTION SPEED ZONE SIGNS

•••• R10-1108p shall only be used along roadways under the jurisdiction of the State.

TRAFFIC CONTROL DEVICES

STANDARD 701901-05

Illinois Department of Transportation

APPROVED _____ April 1, 2016

ENGINEER OF OPERATIONS _____

APPROVED _____ April 1, 2016

ENGINEER OF DESIGN AND ENVIRONMENT _____

ISSUED 1-1-97

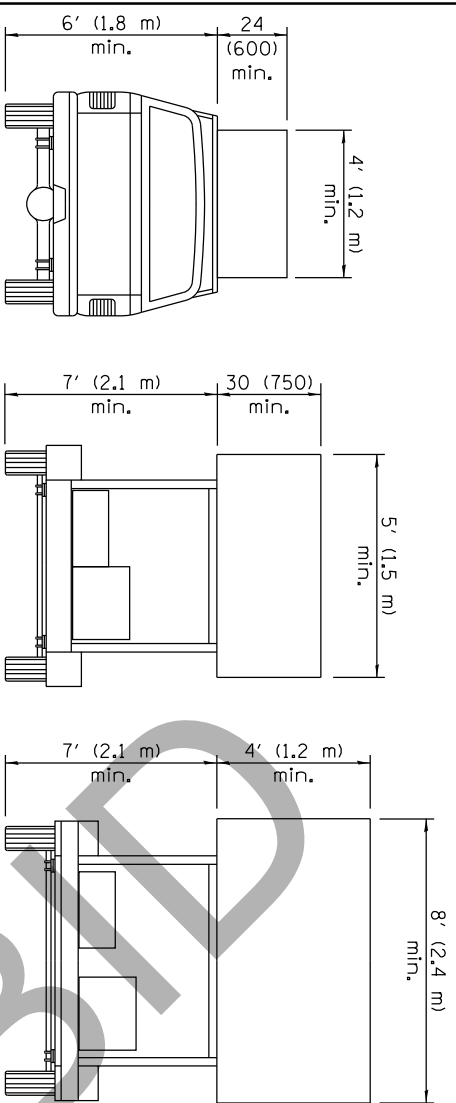

ARROW BOARDS

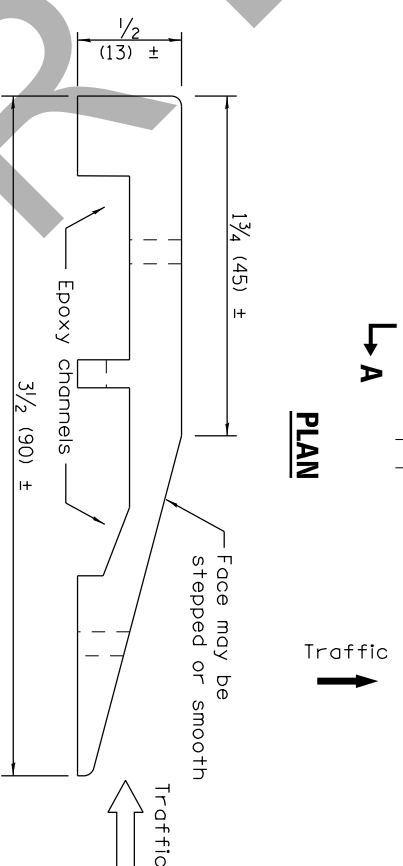
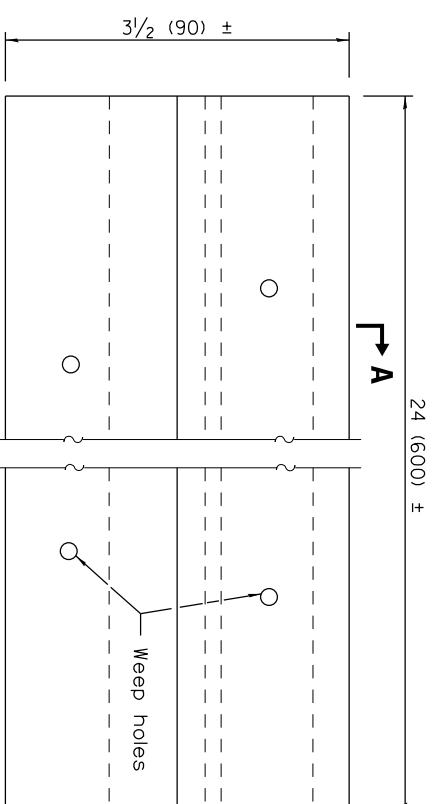

TEMPORARY RUMBLE STRIPS

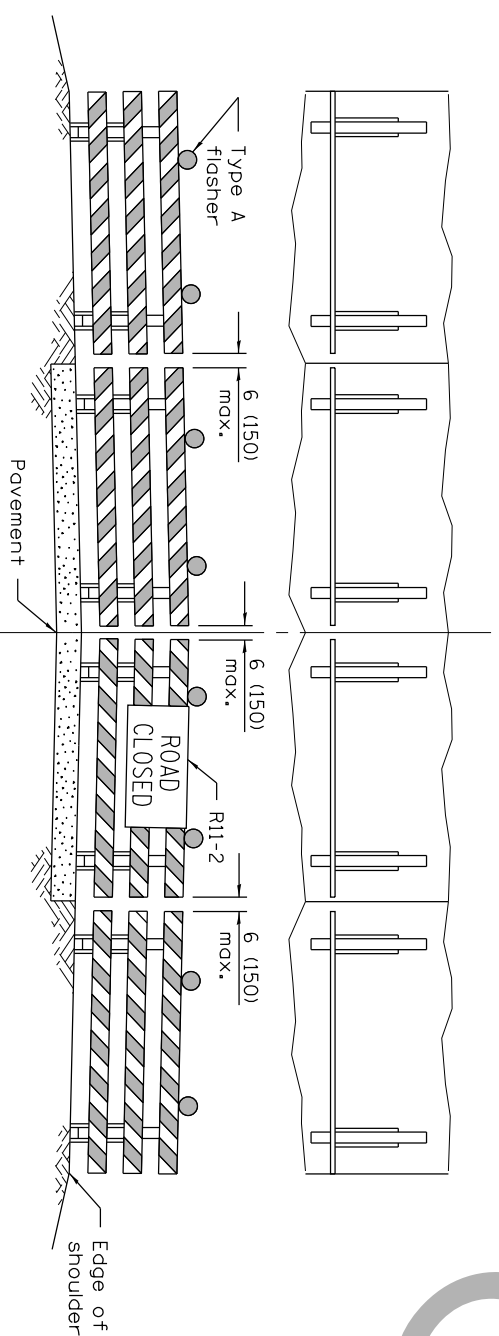
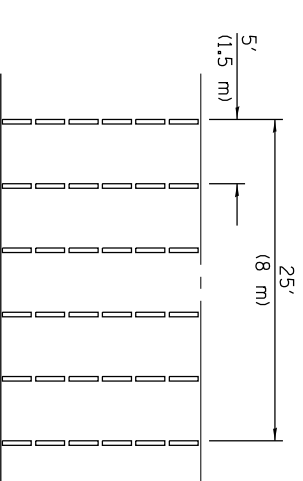
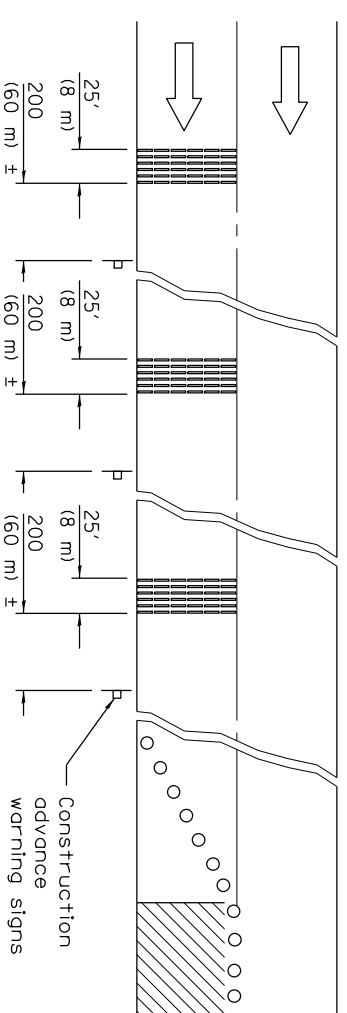

ReflectORIZED striping may be omitted on the back side of the barricades. If a Type III barricade with an attached sign panel which meets NCHRP 350 is not available, the sign may be mounted on an NCHRP 350 temporary sign support directly in front of the barricade.

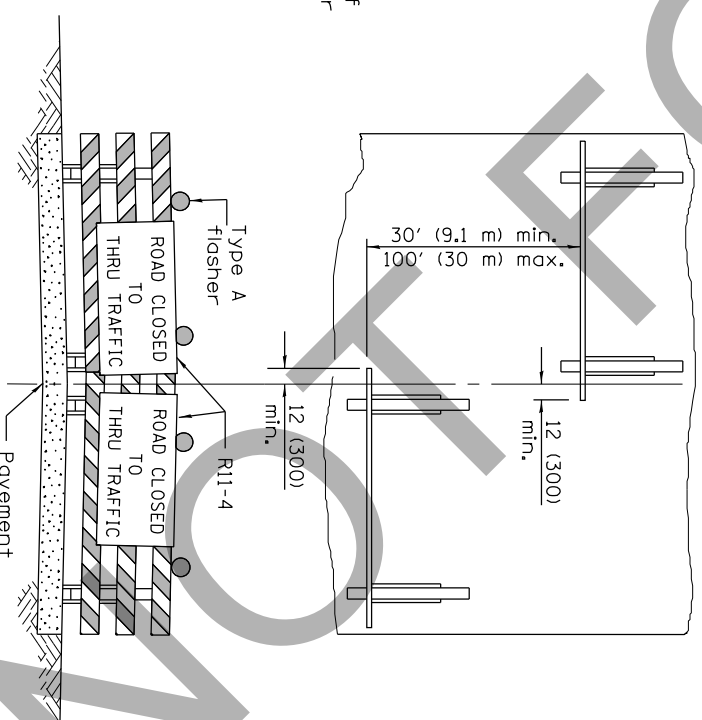

ReflectORIZED striping shall appear on both sides of the barricades. If a Type III barricade which meets NCHRP 350 is not available, the signs may be mounted on NCHRP 350 temporary sign supports directly in front of the barricade.

TRAFFIC CONTROL DEVICES

(Sheet 3 of 3)

STANDARD 701901-05

Illinois Department of Transportation
APPROVED: _____ April 1, 2016
ENGINEER OF OPERATIONS
APPROVED: _____ April 1, 2016
ENGINEER OF DESIGN AND ENVIRONMENT
ISSUED 1-1-97

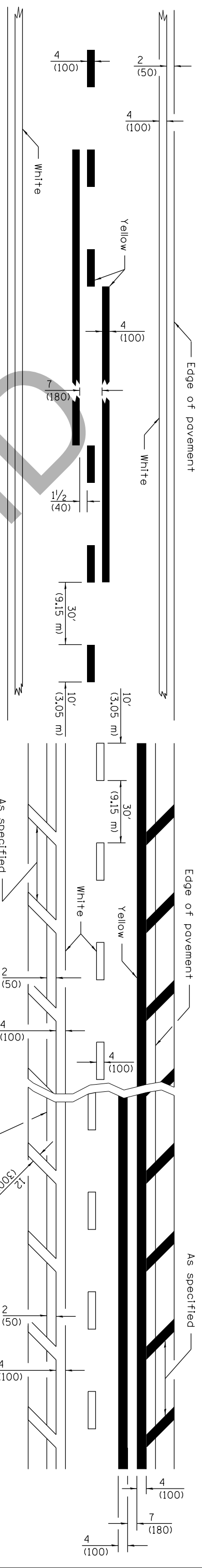

2 LANE

LANE AND EDGE LINES

MULTI LANE

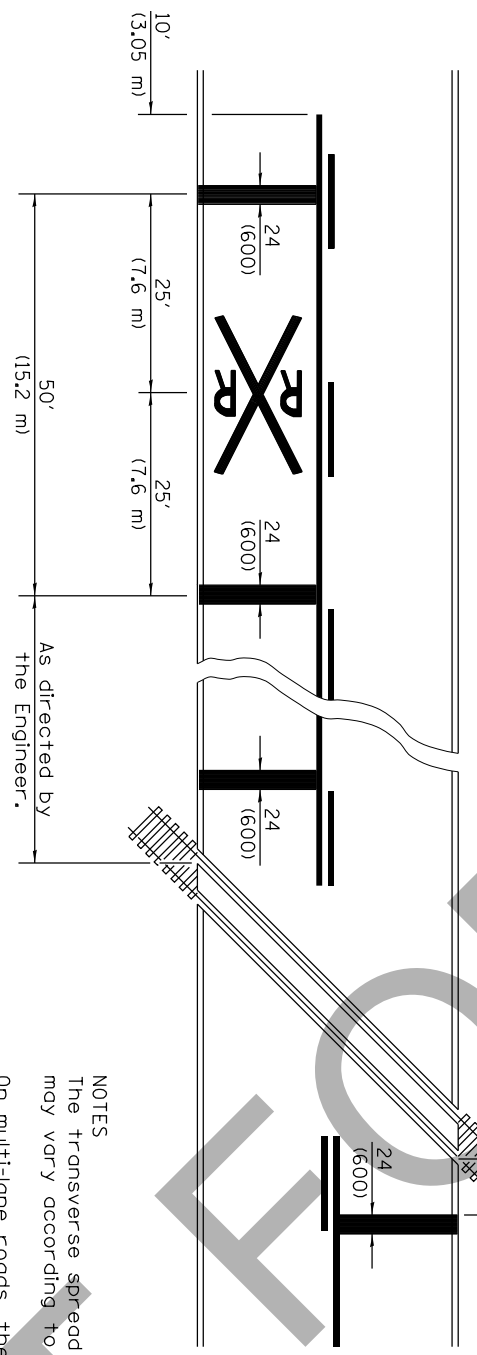

Approximately 15' (4.5 m) from nearest rail or 8' (2.4 m) back from gate, if present. Stop line placed perpendicular to center line.

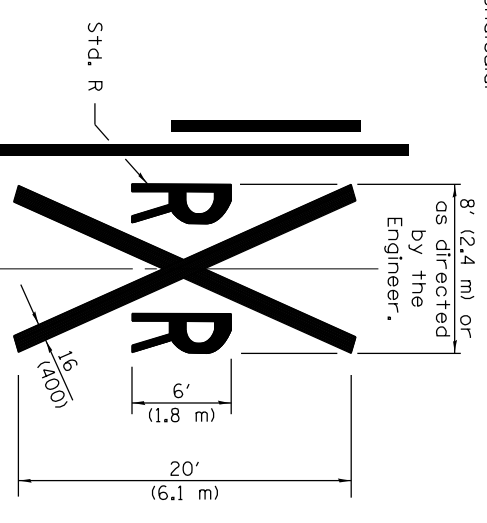

NOTES
 The transverse spread of the "X" may vary according to lane width.
 On multi-lane roads, the stop lines shall extend across all approach lanes and separate RXR symbols shall be placed adjacent to each other in each lane.

When the pavement marking symbol is used, a portion of the symbol should be located directly adjacent to the Advance Warning Sign (W10-1) as placed by Table 2C-4, Condition B of the MUTCD.

All dimensions are in inches (millimeters) unless otherwise shown.

Illinois Department of Transportation

APPROVED January 1, 2015
 ENGINEER OF OPERATIONS
 APPROVED January 1, 2015
 ENGINEER OF DESIGN AND ENVIRONMENT

PAVEMENT MARKINGS AT RAILROAD-HIGHWAY GRADE CROSSING

TYPICAL PAVEMENT MARKINGS

DATE	REVISIONS	STANDARD 780001-05 (Sheet 1 of 3)
1-1-15	Added symbols. Revised bike symbol. Revised note for stop line at RR crossing.	
1-1-14	Added bike symbol. Renamed 'LANE DROP ARROW' detail to 'LANE-REDUCTION ARROW'.	

A B C D E F G H I J
 K L M N O P Q R S
 T U V W X Y Z 1 2
 3 4 5 6 7 8 9 0

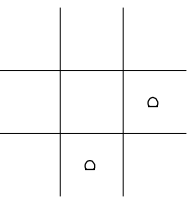
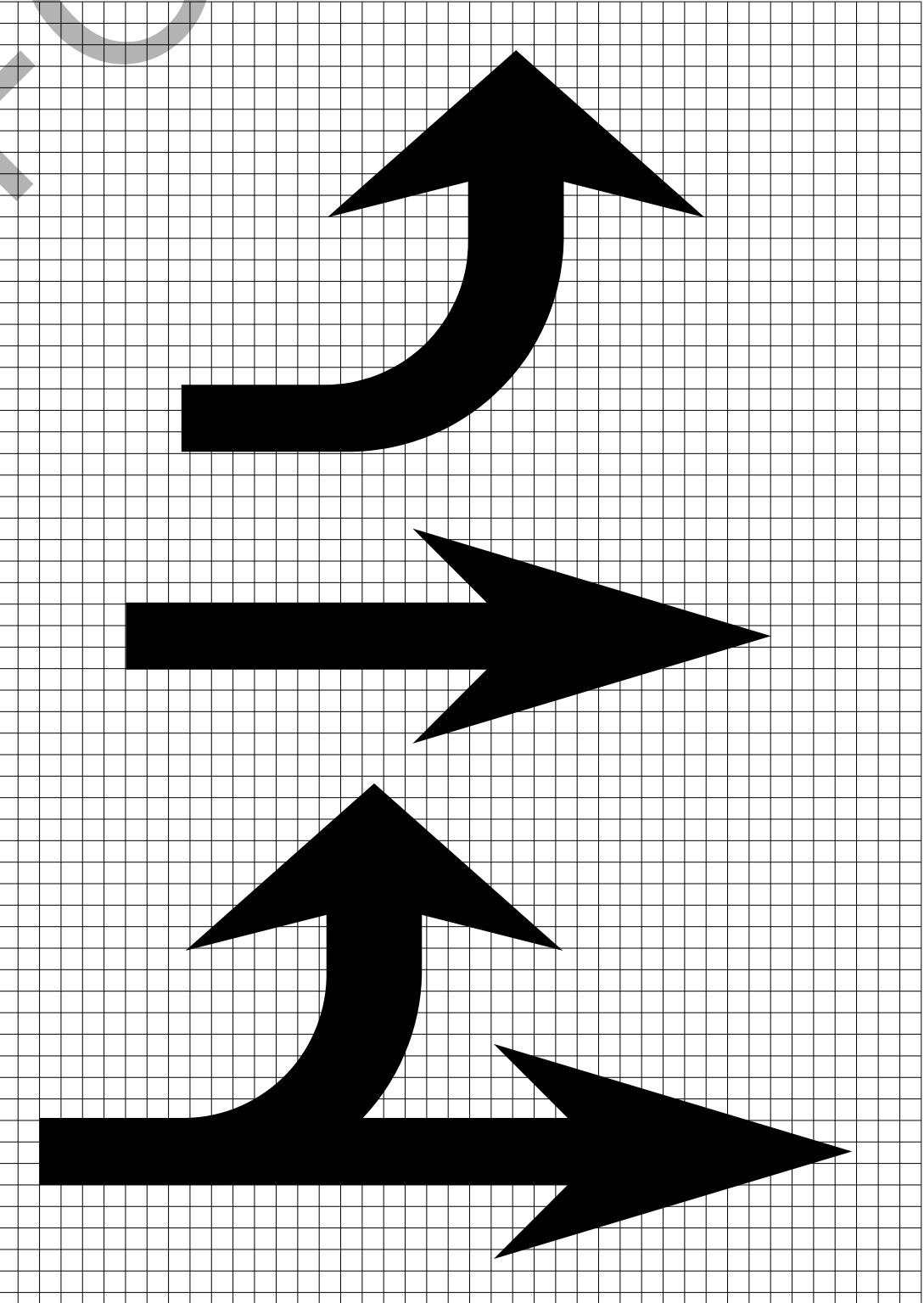

The space between adjacent letters or numerals should be approximately 3 (75) for 6' (1.8 m) legend and 4 (100) for 8' (2.4 m) legend.

Legend Height	Arrow Size	d
6' (1.8 m)	Small	2.9 (74)
8' (2.4 m)	Large	3.8 (96)

LETTER AND ARROW GRID SCALE

NOT FOR

Illinois Department of Transportation
 APPROVED January 1, 2015
 ENGINEER OF OPERATIONS
 APPROVED January 1, 2015
 ENGINEER OF DESIGN AND ENVIRONMENT
 ISSUED 1-1-97

TYPICAL PAVEMENT MARKINGS
 STANDARD 780001-05
 (Sheet 2 of 3)

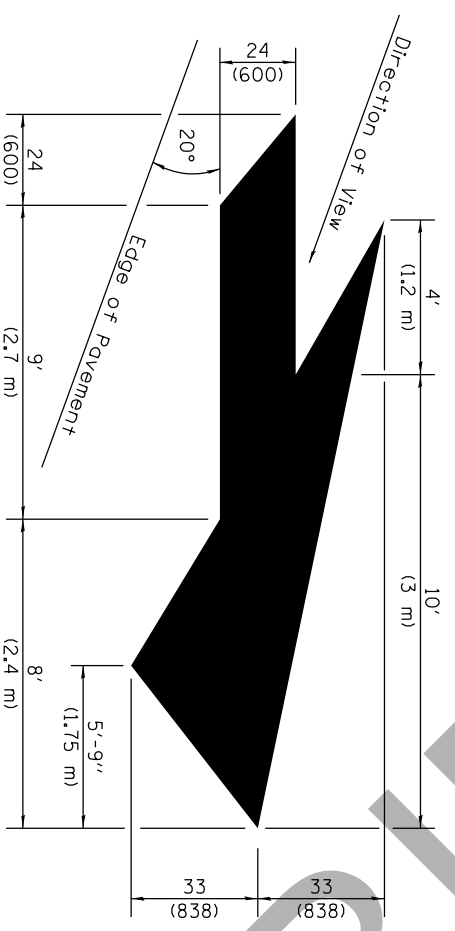

LANE-REDUCTION ARROW

Right lane-reduction arrow shown.
Use mirror image for left lane.

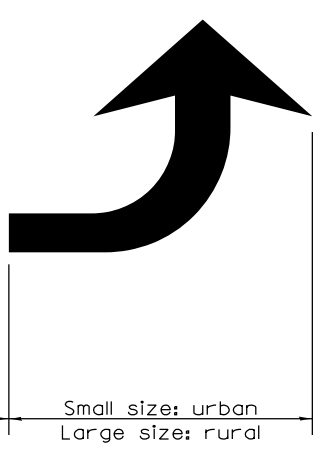

20' (6 m): urban
50' (15 m): rural
(Between arrow and word or between words)

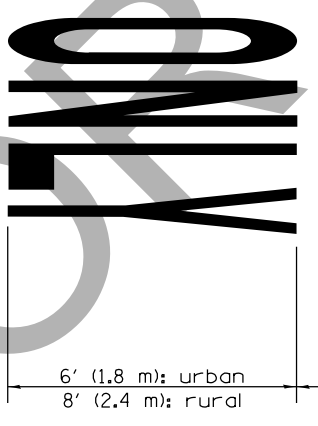

WORD AND ARROW LAYOUT

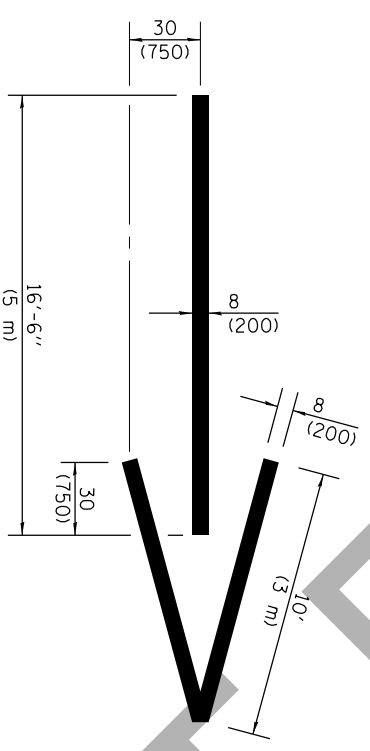

WRONG WAY ARROW

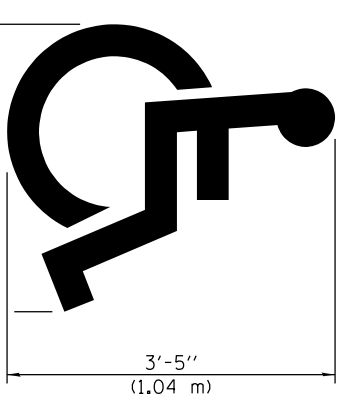

INTERNATIONAL SYMBOL OF ACCESSIBILITY

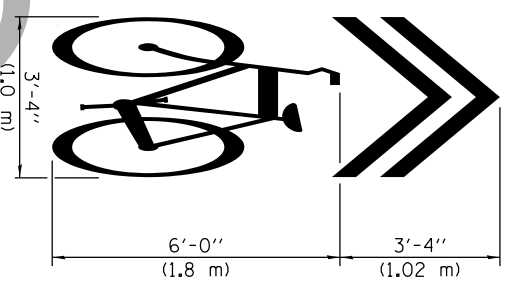

SHARED LANE SYMBOL

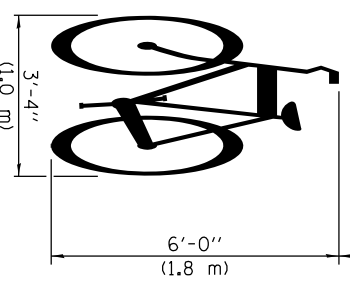
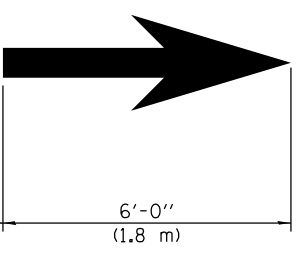

BIKE SYMBOL
(Arrow is optional.)

TYPICAL PAVEMENT MARKINGS

Illinois Department of Transportation
 APPROVED January 1, 2015
 ENGINEER OF OPERATIONS
 APPROVED January 1, 2015
 ENGINEER OF DESIGN AND ENVIRONMENT
 ISSUED 1-1-97

STANDARD 780001-05
 (Sheet 3 of 3)

NOT FOR BID

APPENDIX 3

ORDINANCE AMENDING THE REQUIREMENTS OF BIDDERS FOR CONSTRUCTION PROJECTS
IRMA CONTRACTUAL INSURANCE GUIDELINES

NOT FOR BID

NOT FOR BID

Ordinance No. 3733

AN ORDINANCE OF THE VILLAGE OF VILLA PARK, DUPAGE COUNTY, ILLINOIS AMENDING THE REQUIREMENTS OF BIDDERS FOR CONSTRUCTION PROJECTS

WHEREAS, the Village of Villa Park (the “*Village*”) is a duly organized and validly existing non home-rule municipality created in accordance with the Constitution of the State of Illinois of 1970 and the laws of the State; and,

WHEREAS, section 8-9-1 of the Illinois Municipal Code (65 ILCS 5/8-9-2) allows the Village to require competitive bidding after advertising for bids in the manner prescribed by ordinance; and,

WHEREAS, the President and Board of Trustees desire to adopt purchasing procedures to provide for additional requirements of bidders for construction projects to have active apprenticeship and training programs approved and registered with the United States Department of Labor’s Bureau of Apprenticeship and Training and to have bidders show three similar projects they constructed within the last five years.

NOW, THEREFORE, BE IT ORDAINED by the President and Board of Trustees of the Village of Villa Park, DuPage County, Illinois, as follows:

Section 1. That Section 2-219 of the Villa Park Municipal Code, as amended, be and is hereby amended by placing the existing text as subsection A. and adding a new subsection B. to read as follows:

“B. A responsible bidder for the construction of public works projects shall meet and submit evidence of compliance with the following requirements:

- (1) All applicable laws prerequisite to doing business in the State of Illinois,
- (2) A federal employer tax identification number or social security number,
- (3) Provision of Section 2000(e) of Chapter 21, Title 42 of the United States Code and Federal Executive Order No. 11246 as amended by Executive Order No. 11375 (known as the Equal Opportunity Employer provisions),
- (4) Certificates of insurance indicating the following coverage’s: general liability, worker’s compensation, completed operations, automobile, hazardous occupation and product liability
- (5) Compliance with all provisions of the Illinois Prevailing Wage Act, including wages, medical and hospitalization insurance and retirement for those trades covered in the Act,
- (6) The bidder and all bidder’s sub-contractors must participate in active apprenticeship and training programs approved and registered with the United States Department of Labor’s Bureau of Apprenticeship and Training for each of the trades of work contemplated under the proposed contract,
- (7) All contractors and sub-contractors are required to file certified payrolls as specified in Illinois Pubic Act 94-0515, and follow all provisions of the Employee Classification Act (820 ILCS 185/1 et seq.), and

(8) All bidders must provide three (3) projects of a similar nature constructed in the immediate past five (5) years with the name, address and telephone number of the contact person having knowledge of the project along with three (3) references (name, address, and telephone number) with knowledge of the integrity and business practices of the bidder.”

Section 2. This Ordinance shall be in full force and effect upon its passage, approval, and publication as provided by law.

Passed this 11 day of February, 2013.

AYES: ALL

NAYS: Aiello Bulthuis

ABSENT: _____

Approved this 11 day of February, 2013.

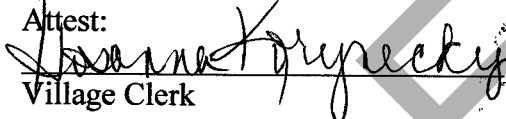

Village President

Attest:

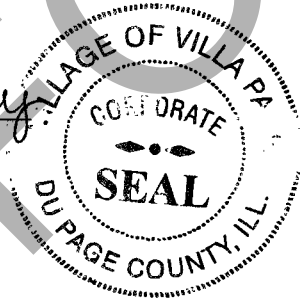
Village Clerk



Published in pamphlet form:

2-11, 2013

IRMA

CONTRACTUAL INSURANCE GUIDELINES

I. INSURANCE REQUIREMENTS

Contractor shall procure and maintain, for the duration of the contract, insurance against claims for injuries to persons or damages to property, which may arise from or in connection with the performance of the work hereunder by the Contractor, his agents, representatives, employees or subcontractors.

MINIMUM SCOPE OF INSURANCE

Coverage shall be at least as broad as:

- A. Insurance Services Office Commercial General Liability occurrence form CG 0001 with the member named as additional insured, on a form at least as broad as the attached sample endorsement including ISO Additional Insured Endorsement CG 2010 (Exhibit A), CG 2026 (Exhibit B).

CG2037 - Completed Operations – (Exhibit C)

Required if box is checked ; and

- B. Owners and Contractors Protective Liability (OCP) policy with the member as insured

Required if box is checked ; and

- C. Insurance Service Office Business Auto Liability coverage form number CA 0001, Symbol 01 "Any Auto."

- D. Workers' Compensation as required by the Workers' Compensation Act of the State of Illinois and Employers' Liability insurance.

Coverage required for employee exposure to lead, if box is checked

- E. Builder Risk Property Coverage with member as loss payee

Required if box is checked .

- F. Environmental Impairment/Pollution Liability Coverage for pollution incidents as a result of a claim for bodily injury, property damage or remediation costs from an incident at, on or migrating beyond the contracted work site. Coverage shall be extended to Non-Owned Disposal sites resulting from a pollution incident at, on or mitigating beyond the site; and also provide coverage for incidents occurring during transportation of pollutants.

Required if box is checked .

MINIMUM LIMITS OF INSURANCE

Contractor shall maintain limits no less than the following, **if required under above scope**:

- A. Commercial General Liability: \$1,000,000 combined single limit per occurrence for bodily injury, and property damage and \$1,000,000 per occurrence for personal injury. The general aggregate shall be twice the required occurrence limit. Minimum General Aggregate shall be no less than \$2,000,000 or a project/contract

specific aggregate of \$1,000,000.

- B. Owners and Contractors Protective Liability (OCP): \$1,000,000 combined single limit per occurrence for bodily injury and property damage.
- C. Business Automobile Liability: \$1,000,000 combined single limit per accident for bodily injury and property damage.
- D. Workers' Compensation and Employers' Liability: Workers' Compensation coverage with statutory limits and Employers' Liability limits of \$500,000 per accident.
- E. Builder's Risk: Shall insure against "All Risk" of physical damage, including water damage (flood and hydrostatic pressure not excluded), on a completed replacement cost basis.
- F. Environmental Impairment/Pollution Liability: \$1,000,000 combined single limit per occurrence for bodily injury, property damage and remediation costs.

DEDUCTIBLES AND SELF-INSURED RETENTIONS

Any deductibles or self-insured retentions must be declared to and approved by the member. At the option of the member, either: the insurer shall reduce or eliminate such deductibles or self-insured retentions as respects the member, its officials, employees, agents and volunteers; or the Contractor shall procure a bond guaranteeing payment of losses and related investigation, claim administration and defense expenses.

OTHER INSURANCE PROVISIONS

The policies are to contain, or be endorsed to contain, the following provisions:

A. General Liability and Automobile Liability Coverages

1. The member, its officials, agents, employees and volunteers are to be covered as additional insureds as respects: liability arising out of the Contractor's work, including activities performed by or on behalf of the Contractor; products and completed operations of the Contractor; premises owned, leased or used by the Contractor; or automobiles owned, leased, hired or borrowed by the Contractor. The coverage shall contain no special limitations on the scope of protection afforded to the member, its officials, agents, employees and volunteers.
2. The Contractor's insurance coverage shall be primary as respects the member, its officials, employees, agents and volunteers. Any insurance or self-insurance maintained by the member, its officials, agents, employees and volunteers shall be excess of Contractor's insurance and shall not contribute with it.
3. Any failure to comply with reporting provisions of the policies shall not affect coverage provided to the member, its officials, employees, agents and volunteers.
4. The Contractor's insurance shall contain a Severability of Interests/Cross Liability clause or language stating that Contractor's insurance shall apply

separately to each insured against whom claim is made or suit is brought, except with respect to the limits of the insurer's liability.

5. If any commercial general liability insurance is being provided under an excess or umbrella liability policy that does not "follow form," then the Contractor shall be required to name the member, its officials, employees, agents and volunteers as additional insureds.
6. All general liability coverages shall be provided on an occurrence policy form. Claims-made general liability policies will not be accepted.
7. The contractor and all subcontractors hereby agree to waive any limitation as to the amount of contribution recoverable against them by member. This specifically includes any limitation imposed by any state statute, regulation, or case law including any Workers' Compensation Act provision that applies a limitation to the amount recoverable in contribution such as Kotecki v. Cyclops Welding.

B. Workers' Compensation and Employers' Liability Coverage

The insurer shall agree to waive all rights of subrogation against the member, its officials, employees, agents and volunteers for losses arising from work performed by Contractor for the municipality.

1. NCCI Alternate Employer Endorsement (WC 000301) in place to insure that workers' compensation coverage applies under contractor's coverage rather than member's if the member is borrowing, leasing or in day to day control of contractor's employee.

Required if box is checked .

C. Professional Liability (Required if box is checked)

1. Professional liability insurance with limits not less than \$1,000,00 each claim with respect to negligent acts, errors and omissions in connection with professional services to be provided under the contract, with a deductible not-to-exceed \$50,000 without prior written approval.
2. If the policy is written on a claims-made form, the retroactive date must be equal to or preceding the effective date of the contract. In the event the policy is cancelled, non-renewed or switched to an occurrence form, the Contractor shall be required to purchase supplemental extending reporting period coverage for a period of not less than three (3) years.
3. Provide a certified copy of actual policy for review.
4. Recommended Required Coverage (architect, engineer, surveyor, consultant): Professional liability insurance that provides indemnification and defense for injury or damage arising out of acts, errors, or omissions in providing the following professional services, but not limited to the following:
 - a. Preparing, approving or failure to prepare or approve maps, drawings, opinions, report, surveys, change orders, designs or specifications;
 - b. Providing direction, instruction, supervision, inspection, engineering

services or failing to provide them, if that is the primary cause of injury or damage.

D. All Coverages

Each insurance policy required shall have the member expressly endorsed onto the policy as a Cancellation Notice Recipient. Should any of the policies be cancelled before the expiration date thereof, notice will be delivered in accordance with the policy provisions.

ACCEPTABILITY OF INSURERS

Insurance is to be placed with insurers with a Best's rating of no less than A-, VII and licensed to do business in the State of Illinois.

VERIFICATION OF COVERAGE

Contractor shall furnish the member with certificates of insurance naming the member, its officials, employees, agents and volunteers as additional insureds (Exhibit D), and with original endorsements affecting coverage required by this clause. The certificates and endorsements for each insurance policy are to be signed by a person authorized by that insurer to bind coverage on its behalf. The certificates and endorsements are to be received and approved by the member before any work commences. The following additional insured endorsements may be utilized: ISO Additional Insured Endorsements CG 2010 (Exhibit A) or CG 2026 (Exhibit B), and CG 2037 (Exhibit C) – Completed Operations, where required. The member reserves the right to request full certified copies of the insurance policies and endorsements.

SUBCONTRACTORS

Contractor shall include all subcontractors as insureds under its policies or shall furnish separate certificates and endorsements for each subcontractor. All coverages for subcontractors shall be subject to all of the requirements stated herein.

ASSUMPTION OF LIABILITY

The contractor assumes liability for all injury to or death of any person or persons including employees of the contractor, any sub-contractor, any supplier or any other person and assumes liability for all damage to property sustained by any person or persons occasioned by or in any way arising out of any work performed pursuant to this agreement.

II. INDEMNITY/HOLD HARMLESS PROVISION

To the fullest extent permitted by law, the Contractor hereby agrees to defend, indemnify and hold harmless the member, its officials, employees and agents against all injuries, deaths, loss, damages, claims, patent claims, suits, liabilities, judgments, cost and expenses, which may in anywise accrue against the member, its officials, agents and employees, arising in whole or in part or in consequence of the performance of this work by the Contractor, its employees, or subcontractors, or which may in anywise result therefore, except that arising out of the sole legal cause of the member, its employees or agents, the Contractor shall, at its own expense, appear, defend and pay all charges of attorneys and all costs and other expenses arising therefore or incurred in connections

therewith, and, if any judgment shall be rendered against the member, its officials, employees and agents, in any such action, the Contractor shall, at its own expense, satisfy and discharge the same.

Contractor expressly understands and agrees that any performance bond or insurance policies required by this contract, or otherwise provided by the Contractor, shall in no way limit the responsibility to indemnify, keep and save harmless and defend the member, its officials, employees and agents as herein provided.

The Contractor further agrees that to the extent that money is due the Contractor by virtue of this contract as shall be considered necessary in the judgment of the member, may be retained by the member to protect itself against said loss until such claims, suits, or judgments shall have been settled or discharged and/or evidence to that effect shall have been furnished to the satisfaction of the member.

III. SAFETY/LOSS PREVENTION

Safety/Loss Prevention Program Requirements

- Successful bidder will provide written confirmation that a safety/loss prevention program was in place at least 90 days prior to submitting the bid proposal.
- Evidence of completed employee safety training can be provided.

Regulatory Requirements

- Successful bidder must comply with all applicable laws, regulations, and rules promulgated by any Federal, State, County, Municipal and/or other governmental unit or regulatory body now in effect or which may be in effect during the performance of the work. Included within the scope of the laws, regulations, and rules referred to in this paragraph but in no way to operate as a limitation, are Occupational Safety & Health Act (OSHA), Illinois Department of Labor (IDOL), Department of Transportation, all forms of traffic regulations, public utility, Intrastate and Interstate Commerce Commission regulations, Workers' Compensation Laws, Prevailing Wage Laws, the Social Security Act of the Federal Government and any of its titles, the Illinois Department of Human Rights, Human Rights Commission, or EEOC statutory provisions and rules and regulations.
- Evidence of specific regulatory compliance will be provided by bidder, if required by owner.

EXHIBIT A

POLICY NUMBER:

COMMERCIAL GENERAL LIABILITY
CG 20 10 07 04

THIS ENDORSEMENT CHANGES THE POLICY. PLEASE READ IT CAREFULLY.

**ADDITIONAL INSURED – OWNERS, LESSEES OR
CONTRACTORS – SCHEDULED PERSON OR
ORGANIZATION**

This endorsement modifies insurance provided under the following:

COMMERCIAL GENERAL LIABILITY COVERAGE PART

SCHEDULE

Name Of Additional Insured Person(s) Or Organization(s):	Location(s) Of Covered Operations
Information required to complete this Schedule, if not shown above, will be shown in the Declarations.	

A. Section II – Who Is An Insured is amended to include as an additional insured the person(s) or organization(s) shown in the Schedule, but only with respect to liability for "bodily injury", "property damage" or "personal and advertising injury" caused, in whole or in part, by:

1. Your acts or omissions; or
2. The acts or omissions of those acting on your behalf;

in the performance of your ongoing operations for the additional insured(s) at the location(s) designated above.

B. With respect to the insurance afforded to these additional insureds, the following additional exclusions apply:

This insurance does not apply to "bodily injury" or "property damage" occurring after:

1. All work, including materials, parts or equipment furnished in connection with such work, on the project (other than service, maintenance or repairs) to be performed by or on behalf of the additional insured(s) at the location of the covered operations has been completed; or
2. That portion of "your work" out of which the injury or damage arises has been put to its intended use by any person or organization other than another contractor or subcontractor engaged in performing operations for a principal as a part of the same project.

**EXHIBIT
C**

POLICY NUMBER:

COMMERCIAL GENERAL LIABILITY
CG 20 37 07 04

THIS ENDORSEMENT CHANGES THE POLICY. PLEASE READ IT CAREFULLY.

**ADDITIONAL INSURED – OWNERS, LESSEES OR
CONTRACTORS – COMPLETED OPERATIONS**

This endorsement modifies insurance provided under the following:

COMMERCIAL GENERAL LIABILITY COVERAGE PART

SCHEDULE

Name Of Additional Insured Person(s) Or Organization(s):	Location And Description Of Completed Operations

Information required to complete this Schedule, if not shown above, will be shown in the Declarations.

Section II – Who Is An Insured is amended to include as an additional insured the person(s) or organization(s) shown in the Schedule, but only with respect to liability for "bodily injury" or "property damage" caused, in whole or in part, by "your work" at the location designated and described in the schedule of this endorsement performed for that additional insured and included in the "products-completed operations hazard".



Exhibit D (Example)

CERTIFICATE OF LIABILITY INSURANCE

DATE (MM/DD/YYYY)

THIS CERTIFICATE IS ISSUED AS A MATTER OF INFORMATION ONLY AND CONFERS NO RIGHTS UPON THE CERTIFICATE HOLDER. THIS CERTIFICATE DOES NOT AFFIRMATIVELY OR NEGATIVELY AMEND, EXTEND OR ALTER THE COVERAGE AFFORDED BY THE POLICIES BELOW. THIS CERTIFICATE OF INSURANCE DOES NOT CONSTITUTE A CONTRACT BETWEEN THE ISSUING INSURER(S), AUTHORIZED REPRESENTATIVE OR PRODUCER, AND THE CERTIFICATE HOLDER.

IMPORTANT: If the certificate holder is an ADDITIONAL INSURED, the policy(ies) must be endorsed. If SUBROGATION IS WAIVED, subject to the terms and conditions of the policy, certain policies may require an endorsement. A statement on this certificate does not confer rights to the certificate holder in lieu of such endorsement(s).

PRODUCER Name of Insurance Broker	CONTACT NAME: Producer/Ins. Broker Contact Info.	
	PHONE (A/C, No, Ext):	FAX (A/C, No):
E-MAIL ADDRESS:		
INSURED Name of Contractor	INSURER(S) AFFORDING COVERAGE	
	INSURER A: Name of Insurance Company	NAIC # Completed
	INSURER B: Name of Insurance Company	Completed
	INSURER C:	
	INSURER D:	
	INSURER E:	

COVERAGES CERTIFICATE NUMBER: REVISION NUMBER:

THIS IS TO CERTIFY THAT THE POLICIES OF INSURANCE LISTED BELOW HAVE BEEN ISSUED TO THE INSURED NAMED ABOVE FOR THE POLICY PERIOD INDICATED. NOTWITHSTANDING ANY REQUIREMENT, TERM OR CONDITION OF ANY CONTRACT OR OTHER DOCUMENT WITH RESPECT TO WHICH THIS CERTIFICATE MAY BE ISSUED OR MAY PERTAIN, THE INSURANCE AFFORDED BY THE POLICIES DESCRIBED HEREIN IS SUBJECT TO ALL THE TERMS, EXCLUSIONS AND CONDITIONS OF SUCH POLICIES. LIMITS SHOWN MAY HAVE BEEN REDUCED BY PAID CLAIMS.

INSR LTR	TYPE OF INSURANCE	ADDE INSR	SUBR WVD	POLICY NUMBER	POLICY EFF (MM/DD/YYYY)	POLICY EXP (MM/DD/YYYY)	LIMITS	
A	GENERAL LIABILITY			Policy Number Inserted	Policy Start Date	Policy Start Date	EACH OCCURRENCE \$ 1,000,000	
	<input checked="" type="checkbox"/> COMMERCIAL GENERAL LIABILITY						DAMAGE TO RENTED PREMISES (Ea occurrence) \$ 50,000	
	<input type="checkbox"/> CLAIMS-MADE <input type="checkbox"/> OCCUR Owners & Cont.Prot. (OCP) if requested	Y	Y				MED EXP (Any one person) \$ 5,000	
	GEN'L AGGREGATE LIMIT APPLIES PER:						PERSONAL & ADV INJURY \$ 1,000,000	
	<input checked="" type="checkbox"/> POLICY <input type="checkbox"/> PRO-JECT <input type="checkbox"/> LOC						GENERAL AGGREGATE \$ 2,000,000	
							PRODUCTS - COMP/OP AGG \$ 1,000,000	
A	AUTOMOBILE LIABILITY			Policy Number Inserted	Policy Start Date	Policy Start Date	COMBINED SINGLE LIMIT (Ea accident) \$ 1,000,000	
	<input checked="" type="checkbox"/> ANY AUTO						BODILY INJURY (Per person) \$	
	<input type="checkbox"/> ALL OWNED AUTOS <input type="checkbox"/> SCHEDULED AUTOS <input type="checkbox"/> NON-OWNED AUTOS						BODILY INJURY (Per accident) \$	
	<input type="checkbox"/> HIRED AUTOS						PROPERTY DAMAGE (Per accident) \$	
A	<input checked="" type="checkbox"/> UMBRELLA LIAB			Policy Number Inserted	Policy Start Date	Policy Start Date	EACH OCCURRENCE \$ Per Request	
	<input checked="" type="checkbox"/> EXCESS LIAB						AGGREGATE \$ Per Request	
	<input type="checkbox"/> OCCUR <input type="checkbox"/> CLAIMS-MADE	Y	Y					
	DED <input type="checkbox"/> RETENTION \$							
B	WORKERS COMPENSATION AND EMPLOYERS' LIABILITY			Policy Number Inserted	Policy Start Date	Policy Start Date	<input checked="" type="checkbox"/> WC STATU-TORY LIMITS	
	ANY PROPRIETOR/PARTNER/EXECUTIVE OFFICER/MEMBER EXCLUDED? (Mandatory in NH)	Y/N <input type="checkbox"/> Y <input checked="" type="checkbox"/> N	N/A				Y	E.L EACH ACCIDENT \$ 500,000
	If yes, describe under DESCRIPTION OF OPERATIONS below							E.L DISEASE - EA EMPLOYEE \$ 500,000
								E.L DISEASE - POLICY LIMIT \$ 500,000
	Professional Liability (other specialty coverages as requested)			Policy Number Inserted	Policy Start Date	Policy start Date	\$1,000,000 per occurrence or as requested	

DESCRIPTION OF OPERATIONS / LOCATIONS / VEHICLES (Attach ACORD 101, Additional Remarks Schedule, if more space is required)
 List project number, location and description.
 No additional endorsements limit coverage to additional insured beyond terms of actual additional insured endorsement (CG 2010 or CG 2026). Coverage to additional insured is primary. Additional Insured: Member, its officials, employees, agents and volunteers.
 * Member named as cancellation notice recipient.

CERTIFICATE HOLDER Name of Member	CANCELLATION
	SHOULD ANY OF THE ABOVE DESCRIBED POLICIES BE CANCELLED BEFORE THE EXPIRATION DATE THEREOF, NOTICE WILL BE DELIVERED IN ACCORDANCE WITH THE POLICY PROVISIONS. *
	AUTHORIZED REPRESENTATIVE Signature of authorized insurance company representative

© 1988-2010 ACORD CORPORATION. All rights reserved.

NOT FOR BID

CENTRAL BOULEVARD IMPROVEMENTS
VILLAGE OF VILLA PARK

APPENDIX 4

IEPA NOTICE OF INTENT (NOI)
STORM WATER POLLUTION PREVENTION PLAN
IEPA NOTICE OF TERMINATION (NOT)
DUPAGE COUNTY - APPLICATION FOR HIGHWAY PERMIT
HIGHWAY PERMIT INSURANCE REQUIREMENTS

NOT FOR BID

NOT FOR BID



Illinois Environmental Protection Agency

1021 North Grand Avenue East • P.O. Box 19276 • Springfield • Illinois • 62794-9276 • (217) 782-3397

Division of Water Pollution Control Notice of Intent (NOI) for General Permit to Discharge Storm Water Associated with Construction Site Activities

This fillable form may be completed online, a copy saved locally, printed and signed before it is submitted to the Permit Section at the above address.

For Office Use Only

OWNER INFORMATION

Permit No. ILR10 _____

Company/Owner Name: Village of Villa Park, Dupage County, Illinois

Mailing Address: 20 S. Ardmore Avenue

Phone: (630) 834-8505

City: Villa Park State: IL Zip: 60181

Fax: (630) 834-8509

Contact Person: Vydas Juskelis, P.E.

E-mail: juskelis@invillapark.com

Owner Type (select one) City

MS4 Community: Yes No

CONTRACTOR INFORMATION

Contractor Name: _____

Mailing Address: _____

Phone: _____

City: _____ State: _____ Zip: _____

Fax: _____

CONSTRUCTION SITE INFORMATION

Select One: New Change of information for: ILR10 _____

Project Name: Central Boulevard Improvements

County: DuPage

Street Address: Central Blvd, Myrtle Ave, Cortesi Av City: Villa Park

IL Zip: 60181

Latitude: 41 53 9 Longitude: 87 58 14 10 39N 11E
(Deg) (Min) (Sec) (Deg) (Min) (Sec) Section Township Range

Approximate Construction Start Date _____ Approximate Construction End Date _____

Total size of construction site in acres: 1.9

If less than 1 acre, is the site part of a larger common plan of development?

Yes No

Fee Schedule for Construction Sites:

Less than 5 acres - \$250

5 or more acres - \$750

STORM WATER POLLUTION PREVENTION PLAN (SWPPP)

Has the SWPPP been submitted to the Agency? Yes No

(Submit SWPPP electronically to: epa.constit10swppp@illinois.gov)

Location of SWPPP for viewing: Address: _____

City: Villa Park

SWPPP contact information:

Inspector qualifications:

Contact Name: Vydas Juskelis

P.E. _____

Phone: (630) 834-8505

Fax: (630) 834-8509

E-mail: juskelis@invillapark.com

Project inspector, if different from above

Inspector qualifications:

Inspector's Name: _____

Phone: _____ Fax: _____ E-mail: _____

This Agency is authorized to require this information under Section 4 and Title X of the Environmental Protection Act (415 ILCS 5/4, 5/39). Failure to disclose this information may result in: a civil penalty of not to exceed \$50,000 for the violation and an additional civil penalty of not to exceed \$10,000 for each day during which the violation continues (415 ILCS 5/42) and may also prevent this form from being processed and could result in your application being denied. This form has been approved by the Forms Management Center.

TYPE OF CONSTRUCTION (select one)

Construction Type Transportation

SIC Code: _____

Type a detailed description of the project:

The project consists of the separation of combined sewers and the reconstruction of pavement on various streets which includes installation of new sanitary and storm sewers, manholes, inlets and catch basins, hot-mix asphalt (HMA) pavement reconstruction, curb and gutter, driveway, and sidewalk removal and replacement. The pavement reconstruction areas will be composed of 2" HMA surface course and 4" HMA binder course supported on a 6" aggregate base course with geogrid. In addition, there will be sidewalk replacement at intersections, drainage and utility improvements, pavement markings, erosion & sediment control, and landscaping.

HISTORIC PRESERVATION AND ENDANGERED SPECIES COMPLIANCE

Has the project been submitted to the following state agencies to satisfy applicable requirements for compliance with Illinois law on:

Historic Preservation Agency Yes No

Endangered Species Yes No

RECEIVING WATER INFORMATION

Does your storm water discharge directly to: Waters of the State or Storm Sewer

Owner of storm sewer system: Village of Villa Park

Name of closest receiving water body to which you discharge: Salt Creek

Mail completed form to: Illinois Environmental Protection Agency
Division of Water Pollution Control
Attn: Permit Section
Post Office Box 19276
Springfield, Illinois 62794-9276
or call (217) 782-0610
FAX: (217) 782-9891

Or submit electronically to: epa.constflr10swppp@illinois.gov

I certify under penalty of law that this document and all attachments were prepared under my direction and supervision in accordance with a system designed to assure that qualified personnel properly gather and evaluate the information submitted. Based on my inquiry of the person or persons who manage this system, or those persons directly responsible for gathering the information, the information submitted is, to the best of my knowledge and belief, true, accurate, and complete. I am aware that there are significant penalties for submitting false information, including the possibility of fine and imprisonment. In addition, I certify that the provisions of the permit, including the development and implementation of a storm water pollution prevention plan and a monitoring program plan, will be complied with.

Any person who knowingly makes a false, fictitious, or fraudulent material statement, orally or in writing, to the Illinois EPA commits a Class 4 felony. A second or subsequent offense after conviction is a Class 3 felony. (415 ILCS 5/44(h))

Owner Signature:

Date:

Printed Name:

Title:

INSTRUCTIONS FOR COMPLETION OF CONSTRUCTION ACTIVITY NOTICE OF INTENT (NOI) FORM

Submit original, electronic or facsimile copies. Facsimile and/or electronic copies should be followed-up with submission of an original signature copy as soon as possible. Please write "copy" under the "For Office Use Only" box in the upper right hand corner of the first page.

This fillable form may be completed online, a copy saved locally, printed and signed before it is submitted to the Permit Section at:

Illinois Environmental Protection Agency
Division of Water Pollution Control
Permit Section
Post Office Box 19276
Springfield, Illinois 62794-9276
or call (217) 782-0610

FAX: (217) 782-9891

Or submit electronically to: epa.constilr10swppp@illinois.gov

Reports must be typed or printed legibly and signed.

Any facility that is not presently covered by the General NPDES Permit for Storm Water Discharges From Construction Site Activities is considered a new facility.

If this is a change in your facility information, renewal, etc., please fill in your permit number on the appropriate line, changes of information or permit renewal notifications do not require a fee.

NOTE: FACILITY LOCATION IS NOT NECESSARILY THE FACILITY MAILING ADDRESS, BUT SHOULD DESCRIBE WHERE THE FACILITY IS LOCATED.

Use the formats given in the following examples for correct form completion.

	Example	Format
Section	12	1 or 2 numerical digits
Township	12N	1 or 2 numerical digits followed by "N" or "S"
Range	12W	1 or 2 numerical digits followed by "E" or "W"

For the Name of Closest Receiving Waters, do not use terms such as ditch or channel. For unnamed tributaries, use terms which include at least a named main tributary such as "Unnamed Tributary to Sugar Creek to Sangamon River."

Submission of initial fee and an electronic submission of Storm Water Pollution Prevention Plan (SWPPP) for Initial Permit prior to the Notice of Intent being considered complete for coverage by the ILR10 General Permits. Please make checks payable to: Illinois EPA at the above address.

Construction sites with less than 5 acres of land disturbance - fee is \$250.

Construction sites with 5 or more acres of land disturbance - fee is \$750.

SWPPP should be submitted electronically to: epa.constilr10swppp@illinois.gov. When submitting electronically, use Project Name and City as indicated on NOI form.

NOT FOR BID



Route Various roadways	Marked Route 	Section N/A
Project Number 	County DuPage	Contract Number

This plan has been prepared to comply with the provisions of the National Pollutant Discharge Elimination System (NPDES) Permit No. ILR10 (Permit ILR10), issues by the Illinois Environmental Protection Agency (IEPA) for storm water discharges from construction site activities.

I certify under penalty of law that this document and all attachments were prepared under my direction or supervision in accordance with a system designed to assure that qualified personnel properly gathered and evaluated the information submitted. Based on my inquiry of the person or persons who manage the system, or those persons directly responsible for gathering the information, the information submitted is, to the best of my knowledge and belief, true, accurate and complete. I am aware that there are significant penalties for submitting false information, including the possibility of fine and imprisonment for knowing violations.

Print Name Vydas Juskelis, P.E.	Title Director of Public Works	Agency Village of Villa Park
Signature 	Date 	

I. Site Description

A. Provide a description of the project location (include latitude and longitude):

The proposed work is officially known as the "Central Boulevard Improvements". The project involves various improvements in multiple locations throughout the Village of Villa Park, County of DuPage, State of Illinois:
 Street Improvement: CENTRAL BOULEVARD / MYRTLE AVENUE / CORTESI AVENUE
 Starting Limit: VILLA AVENUE / KENILWORTH AVENUE / CENTRAL BOULEVARD
 Ending Limit: CORNELL AVENUE / KENILWORTH AVENUE / CENTRAL BOULEVARD

B. Provide a description of the construction activity which is subject of this plan:

The project consists of the separation of combined sewers and the reconstruction and resurfacing on various streets which includes installation of new storm sewers, manholes, inlets and catch basins, hot-mix asphalt (HMA) pavement reconstruction, curb and gutter, driveway, and sidewalk removal and replacement, drainage and utility improvements, pavement markings, erosion & sediment control, and restoration and other related and incidental work.
 This project will include approximately 1,220 linear feet of storm sewers. The combined length of road improvements is 2,880 feet. The pavement reconstruction areas will be composed of 2" HMA surface course and 4" HMA binder course supported on a 6" aggregate base course with geotechnical fabric.

C. Provide the estimated duration of this project:

It is anticipated this project will commence May 2017 and last for approximately 5 months.

D. The total area of the construction site is estimated to be 2.46 acres.

The total area of the site estimated to be disturbed by excavation, grading or other activities is 3.46 acres.

E. The following is a weighted average of the runoff coefficient for this project after construction activities are completed:

0.71

F. List all soils found within project boundaries. Include map unit name, slope information and erosivity:

The construction site is considered to be "built up" and contains impervious materials. The soil type is not considered to be erosive.

G. Provide an aerial extent of wetland acreage at the site:

There are no wetlands throughout this project.

H. Provide a description of potentially erosive areas associated with this project:

There are no potentially erosive areas associated with this project.

I. The following is a description of soil disturbing activities by stages, their locations, and their erosive factors (e.g. steepness of slopes, length of scopes, etc.):

Soil disturbing activities include excavation of existing pavement and exposure of a clay subgrade. Disturbance will also occur in existing sodded parkways and topsoils beneath. The site is very flat (less than 2 percent slopes) and does not contain any major slopes.

J. See the erosion control plans and/or drainage plans for this contract for information regarding drainage patterns, approximate slopes anticipated before and after major grading activities, locations where vehicles enter or exit the site and controls to prevent off site sediment tracking (to be added after contractor identifies locations), areas of soil disturbance, the location of major structural and non-structural controls identified in the plan, the location of areas where stabilization practices are expected to occur, surface waters (including wetlands) and locations where storm water is discharged to surface water including wetlands.

K. Identify who owns the drainage system (municipality or agency) this project will drain into:

The Village of Villa Park owns a sewer system which will convey storm water to Salt Creek.

L. The following is a list of General NPDES ILR40 permittees within whose reporting jurisdiction this project is located.

Village of Villa Park

M. The following is a list of receiving water(s) and the ultimate receiving water(s) for this site. The location of the receiving waters can be found on the erosion and sediment control plans:

Salt Creek

N. Describe areas of the site that are to be protected or remain undisturbed. These areas may include steep slopes, highly erodible soils, streams, stream buffers, specimen trees, natural vegetation, nature preserves, etc.

All storm sewer structures will utilize inlet filters.

O. The following sensitive environmental resources are associated with this project, and may have the potential to be impacted by the proposed development:

- Floodplain
- Wetland Riparian
- Threatened and Endangered Species
- Historic Preservation
- 303(d) Listed receiving waters for suspended solids, turbidity, or siltation
- Receiving waters with Total Maximum Daily Load (TMDL) for sediment, total suspended solids, turbidity, or siltation
- Applicable Federal, Tribal, State or Local Programs
- Other

1. 303(d) Listed receiving waters (fill out this section if checked above):

a. The name(s) of the listed water body, and identification of all pollutants causing impairment:

- b. Provide a description of how erosion and sediment control practices will prevent a discharge of sediment resulting from a storm event equal to or greater than a twenty-five (25) year, twenty-four (24) hour rainfall event:

- c. Provide a description of the location(s) of direct discharge from the project site to the 303(d) water body:

- d. Provide a description of the location(s) of any dewatering discharges to the MS4 and/or water body:

2. TMDL (fill out this section if checked above)

- a. The name(s) of the listed water body:

- b. Provide a description of the erosion and sediment control strategy that will be incorporated into the site design that is consistent with the assumptions and requirements of the TMDL:

- c. If a specific numeric waste load allocation has been established that would apply to the project's discharges, provide a description of the necessary steps to meet the allocation:

P. The following pollutants of concern will be associated with this construction project:

- | | |
|---|---|
| <input checked="" type="checkbox"/> Soil Sediment | <input type="checkbox"/> Petroleum (gas, diesel, oil, kerosene, hydraulic oil / fluids) |
| <input checked="" type="checkbox"/> Concrete | <input type="checkbox"/> Antifreeze / Coolants |
| <input checked="" type="checkbox"/> Concrete Truck waste | <input type="checkbox"/> Waste water from cleaning construction equipment |
| <input checked="" type="checkbox"/> Concrete Curing Compounds | <input type="checkbox"/> Other (specify) _____ |
| <input type="checkbox"/> Solid waste Debris | <input type="checkbox"/> Other (specify) _____ |
| <input type="checkbox"/> Paints | <input type="checkbox"/> Other (specify) _____ |
| <input type="checkbox"/> Solvents | <input type="checkbox"/> Other (specify) _____ |
| <input type="checkbox"/> Fertilizers / Pesticides | <input type="checkbox"/> Other (specify) _____ |

II. Controls

This section of the plan addresses the controls that will be implemented for each of the major construction activities described in I.C. above and for all use areas, borrow sites, and waste sites. For each measure discussed, the Contractor will be responsible for its implementation as indicated. The Contractor shall provide to the Resident Engineer a plan for the implementation of the measures indicated. The Contractor and subcontractors, will notify the Resident Engineer of any proposed changes, maintenance, or modifications to keep construction activities compliant with the Permit ILR10. Each such Contractor has signed the required certification on forms which are attached to, and are a part of, this plan:

- A. **Erosion and Sediment Controls:** At a minimum, controls must be coordinated, installed, and maintained to:
1. Minimize the amount of soil exposed during construction activity;
 2. Minimize the disturbance of steep slopes;
 3. Maintain natural buffers around surface waters, direct storm water to vegetated areas to increase sediment removal and maximize storm water infiltration, unless infeasible;
 4. Minimize soil compaction and, unless infeasible, preserve topsoil.

- B. **Stabilization Practices:** Provided below is a description of interim and permanent stabilization practices, including

site- specific scheduling of the implementation of the practices. Site plans will ensure that existing vegetation is preserved where attainable and disturbed portions of the site will be stabilized. Stabilization practices may include but are not limited to: temporary seeding, permanent seeding, mulching, geotextiles, sodding, vegetative buffer strips, protection of trees, preservation of mature vegetation, and other appropriate measures. Except as provided below in II(B)(1) and II(B)(2), stabilization measures shall be initiated **immediately** where construction activities have temporarily or permanently ceased, but in no case more than **one (1) day** after the construction activity in that portion of the site has temporarily or permanently ceases on all disturbed portions of the site where construction will not occur for a period of fourteen (14) or more calendar days.

1. Where the initiation of stabilization measures is precluded by snow cover, stabilization measures shall be initiated as soon as practicable.
2. On areas where construction activity has temporarily ceased and will resume after fourteen (14) days, a temporary stabilization method can be used.

The following stabilization practices will be used for this project:

- | | |
|--|---|
| <input type="checkbox"/> Preservation of Mature Vegetation | <input type="checkbox"/> Erosion Control Blanket / Mulching |
| <input type="checkbox"/> Vegetated Buffer Strips | <input checked="" type="checkbox"/> Sodding |
| <input type="checkbox"/> Protection of Trees | <input type="checkbox"/> Geotextiles |
| <input type="checkbox"/> Temporary Erosion Control Seeding | <input type="checkbox"/> Other (specify) _____ |
| <input type="checkbox"/> Temporary Turf (Seeding, Class 7) | <input type="checkbox"/> Other (specify) _____ |
| <input type="checkbox"/> Temporary Mulching | <input type="checkbox"/> Other (specify) _____ |
| <input type="checkbox"/> Permanent Seeding | <input type="checkbox"/> Other (specify) _____ |

Describe how the stabilization practices listed above will be utilized during construction:

N/A

Describe how the stabilization practices listed above will be utilized after construction activities have been completed:

After the parkway work is completed, the parkways will be restored and sodding will be performed as soon as possible.

- C. **Structural Practices:** Provided below is a description of structural practices that will be implemented, to the degree attainable, to divert flows from exposed soils, store flows or otherwise limit runoff and the discharge of pollutants from exposed areas of the site. Such practices may include but are not limited to: perimeter erosion barrier, earth dikes, drainage swales, sediment traps, ditch checks, subsurface drains, pipe slope drains, level spreaders, storm drain inlet protection, rock outlet protection, reinforced soil retaining systems, gabions, and temporary or permanent sediment basins. The installation of these devices may be subject to Section 404 of the Clean Water Act.

The following stabilization practices will be used for this project:

- | | |
|--|--|
| <input type="checkbox"/> Perimeter Erosion Barrier | <input type="checkbox"/> Rock Outlet Protection |
| <input type="checkbox"/> Temporary Ditch Check | <input type="checkbox"/> Riprap |
| <input checked="" type="checkbox"/> Storm Drain Inlet Protection | <input type="checkbox"/> Gabions |
| <input type="checkbox"/> Sediment Trap | <input type="checkbox"/> Slope Mattress |
| <input type="checkbox"/> Temporary Pipe Slope Drain | <input type="checkbox"/> Retaining Walls |
| <input type="checkbox"/> Temporary Sediment Basin | <input type="checkbox"/> Slope Walls |
| <input type="checkbox"/> Temporary Stream Crossing | <input type="checkbox"/> Concrete Revetment Mats |
| <input type="checkbox"/> Stabilized Construction Exits | <input type="checkbox"/> Level Spreaders |
| <input type="checkbox"/> Turf Reinforcement Mats | <input checked="" type="checkbox"/> Other (specify) Strategic location of stockpiles |
| <input type="checkbox"/> Permanent Check Dams | <input type="checkbox"/> Other (specify) _____ |
| <input type="checkbox"/> Permanent Sediment Basin | <input type="checkbox"/> Other (specify) _____ |
| <input type="checkbox"/> Aggregate Ditch | <input type="checkbox"/> Other (specify) _____ |

Paved Ditch

Other (specify) _____

Describe how the structural practices listed above will be utilized during construction:

Inlet controls will be installed at each drainage structure to prevent material from entering the storm sewer system. The inlet controls consist of bagged inserts with replaceable reinforced filter bags, to trap sediment and debris. The inlet controls will be inspected weekly, or after 0.5" rain, and cleaned when 75% full.

Stockpiles including stone, topsoil, or debris will be placed off of the curb-line and away from drainage structures to ensure proper drainage of roadway. The slopes of the stockpile will not exceed 2:1 to prevent erosion. The topsoil stockpiles are to be removed within the working day or tarped when inclement weather is forecast.

Describe how the structural practices listed above will be utilized after construction activities have been completed:

The structures will be maintained with proper and timely maintenance.

D. Treatment Chemicals

Will polymer flocculents or treatment chemicals be utilized on this project: Yes No

If yes above, identify where and how polymer flocculents or treatment chemicals will be utilized on this project.

E. Permanent Storm Water Management Controls: Provided below is a description of measures that will be installed during the construction process to control volume and pollutants in storm water discharges that will occur after construction operations have been completed. The installation of these devices may be subject to Section 404 of the Clean Water act.

1. Such practices may include but are not limited to: storm water detention structures (including wet ponds), storm water retention structures, flow attenuation by use of open vegetated swales and natural depressions, infiltration of runoff on site, and sequential systems (which combine several practices).

The practices selected for implementation were determined on the basis of the technical guidance in Chapter 41 (Construction Site Storm Water Pollution Control) of the IDOT Bureau of Design & Environment Manual. If practices other than those discussed in Chapter 41 are selected for implementation or if practices are applied to situations different from those covered in Chapter 41, the technical basis for such decisions will be explained below.

2. Velocity dissipation devices will be placed at discharge locations and along the length of any outfall channel as necessary to provide a non-erosive velocity flow from the structure to a water course so that the natural physical and biological characteristics and functions are maintained and protected (e.g. maintenance of hydrologic conditions such as the hydroperiod and hydrodynamics present prior to the initiation of construction activities).

Description of permanent storm water management controls:

Existing and proposed catch basins will be utilized to collect sediment and prevent it from entering the storm sewer system, and ultimately the waterway.

F. Approved State or Local Laws: The management practices, controls, and provisions contained in this plan will be in accordance with IDOT specifications, which are at least as protective as the requirements contained in the Illinois Environmental Protection Agency's Illinois Urban Manual. Procedures and requirements specified in applicable sediment and erosion site plans or storm water management plans approved by local officials shall be described or incorporated by reference in the space provided below. Requirements specified in sediment and erosion site plans, site permits, storm water management site plans or site permits approved by local officials that are applicable to protecting surface water resources are, upon submittal of an NOI, to be authorized to discharge under the Permit ILR10 incorporated by reference and are enforceable under this permit even if they are not specifically included in the plan.

Description of procedures and requirements specified in applicable sediment and erosion site plans or storm water management plans approved by local officials:

The Village of Villa Park will follow their own stormwater management practices. The work of this project will also be governed by IDOT specifications. In the event of a conflict between the two documents, the Engineer shall determine the governing document.

G. Contractor Required Submittals: Prior to conducting any professional services at the site covered by this plan, the

Contractor and each subcontractor responsible for compliance with the permit shall submit to the Resident Engineer a Contractor Certification Statement, BDE 2342a.

1. The Contractor shall provide a construction schedule containing an adequate level of detail to show major activities with implementation of pollution prevention BMPs, including the following items:
 - Approximate duration of the project, including each stage of the project
 - Rainy season, dry season, and winter shutdown dates
 - Temporary stabilization measures to be employed by contract phases
 - Mobilization time frame
 - Mass clearing and grubbing/roadside clearing dates
 - Deployment of Erosion Control Practices
 - Deployment of Sediment Control Practices (including stabilized construction entrances/exits)
 - Deployment of Construction Site Management Practices (including concrete washout facilities, chemical storage, refueling locations, etc.)
 - Paving, saw-cutting, and any other pavement related operations
 - Major planned stockpiling operations
 - Time frame for other significant long-term operations or activities that may plan non-storm water discharges such as dewatering, grinding, etc.
 - Permanent stabilization activities for each area of the project
2. The Contractor and each subcontractor shall provide, as an attachment to their signed Contractor Certification Statement, a discussion of how they will comply with the requirements of the permit in regard to the following items and provide a graphical representation showing location and type of BMPs to be used when applicable:
 - Vehicle Entrances and Exits - Identify type and location of stabilized construction entrances and exits to be used and how they will be maintained.
 - Material delivery, Storage, and Use - Discuss where and how materials including chemicals, concrete curing compounds, petroleum products, etc. will be stored for this project.
 - Stockpile Management - Identify the location of both on-site and off-site stockpiles. Discuss what BMPs will be used to prevent pollution of storm water from stockpiles.
 - Waste Disposal - Discuss methods of waste disposal that will be used for this project.
 - Spill Prevention and Control - Discuss steps that will be taken in the event of a material spill (chemicals, concrete curing compounds, petroleum, etc.).
 - Concrete Residuals and Washout Wastes - Discuss the location and type of concrete washout facilities to be used on this project and how they will be signed and maintained.
 - Litter Management - Discuss how litter will be maintained for this project (education of employees, number of dumpsters, frequency of dumpster pick-up, etc.).
 - Vehicle and Equipment Cleaning and Maintenance - Identify where equipment cleaning and maintenance locations for this project and what BMPs will be used to ensure containment and spill prevention.
 - Dewatering Activities - Identify the controls which will be used during dewatering operations to ensure sediments will not leave the construction site.
 - Polymer Flocculants and Treatment Chemicals - Identify the use and dosage of treatment chemicals and provide the Resident Engineer with Material Safety Data Sheets. Describe procedures on how the chemicals will be used and identify who will be responsible for the use and application of these chemicals. The selected individual must be trained on the established procedures.
 - Additional measures indicated in the plan.

III. Maintenance

When requested by the Contractor, the Resident Engineer will provide general maintenance guides to the Contractor for the practices associated with this project. The following additional procedures will be used to maintain, in good and effective operating conditions, the vegetation, erosion and sediment control measures and other protective measures identified in this plan. It will be Contractor's responsibility to attain maintenance guidelines for any manufactured BMPs which are to be installed and maintained per manufacture's specifications.

The erosion and sediment control measures will be maintained as provided in Section II and inspected by the Engineer as provided below in Section IV. Any deficiencies will be noted to the Contractor and shall be corrected.

IV. Inspections

Qualified personnel shall inspect disturbed areas of the construction site which have not yet been finally stabilized, structural control measures, and locations where vehicles and equipment enter and exit the site using IDOT Storm Water Pollution Prevention Plan Erosion Control Inspection Report (BC 2259). Such inspections shall be conducted at least once every seven (7) calendar days and within twenty-four (24) hours of the end of a storm or by the end of the following business or work day that is 0.5 inch or greater or equivalent snowfall.

Inspections may be reduced to once per month when construction activities have ceased due to frozen conditions. Weekly inspections will recommence when construction activities are conducted, or if there is 0.5" or greater rain event, or a discharge due to snowmelt occurs.

If any violation of the provisions of this plan is identified during the conduct of the construction work covered by this plan, the Resident Engineer shall notify the appropriate IEPA Field Operations Section office by e-mail at: epa.swnoncomp@illinois.gov, telephone or fax within twenty-four (24) hours of the incident. The Resident Engineer shall then complete and submit an "Incidence of Non-Compliance" (ION) report for the identified violation within five (5) days of the incident. The Resident Engineer shall use forms provided by IEPA and shall include specific information on the cause of noncompliance, actions which were taken to prevent any further causes of noncompliance, and a statement detailing any environmental impact which may have resulted from the noncompliance. All reports of non-compliance shall be signed by a responsible authority in accordance with Part VI. G of the Permit ILR10.

The Incidence of Non-Compliance shall be mailed to the following address:

Illinois Environmental Protection Agency
Division of Water Pollution Control
Attn: Compliance Assurance Section
1021 North Grand East
Post Office Box 19276
Springfield, Illinois 62794-9276

Additional Inspections Required:

--

V. Failure to Comply

Failure to comply with any provisions of this Storm Water Pollution Prevention Plan will result in the implementation of a National Pollutant Discharge Elimination System/Erosion and Sediment Control Deficiency Deduction against the Contractor and/or penalties under the Permit ILR10 which could be passed on to the Contractor.

NOT FOR BID



Prior to conducting any professional services at the site covered by this contract, the Contractor and every subcontractor must complete and return to the Resident Engineer the following certification. A separate certification must be submitted by each firm. Attach to this certification all items required by Section II.G of the Storm Water Pollution Prevention Plan (SWPPP) which will be handled by the Contractors/subcontractor completing this form.

Route Various roadways	Marked Route	Section N/A
Project Number	County DuPage	Contract Number

This certification statement is a part of SWPPP for the project described above, in accordance with the General NPDES Permit No. ILR10 issued by the Illinois Environmental Protection Agency.

I certify under penalty of law that I understand the terms of the Permit No. ILR10 that authorizes the storm water discharges associated with industrial activity from the construction site identified as part of this certification.

In addition, I have read and understand all of the information and requirements stated in SWPPP for the above mentioned project; I have received copies of all appropriate maintenance procedures; and, I have provided all documentation required to be in compliance with the Permit ILR10 and SWPPP and will provide timely updates to these documents as necessary.

- Contractor
 Sub-Contractor

Print Name	Signature
Title	Date
Name of Firm	Telephone
Street Address	City/State/Zip

Items which the Contractor/subcontractor will be responsible for as required in Section II.G. of SWPPP:

--

NOT FOR BID



Illinois Environmental Protection Agency

Bureau of Water • 1021 North Grand Avenue East • P.O. Box 19276 • Springfield • Illinois • 62794-9276

Division of Water Pollution Control NOTICE OF TERMINATION (NOT) of Coverage under the General Permit for Storm Water Discharges Associated with Construction Site Activities

This fillable form may be completed online, a copy saved locally, printed and signed before it is submitted to the Permit Section at the above address.

OWNER INFORMATION

Permit No. ILR10

Owner Name: Village of Villa Park, Dupage County, Illinois

Owner Type (select one) City

Mailing Address: 20 S. Ardmore Avenue Phone: (630) 834-8505

City: Villa Park State: IL Zip: 60181 Fax: (630) 834-8509

Contact Person: Vydas Juskelis, P.E. E-mail: juskelis@invillapark.com

CONTRACTOR INFORMATION

Contractor Name: _____

Mailing Address: _____ Phone: _____

City: _____ State: _____ Zip: _____ Fax: _____

CONSTRUCTION SITE INFORMATION

Facility Name: Central Boulevard Improvements

Street Address: Central Blvd, Myrtle Ave., Cortesi Ave

City: Villa Park IL Zip: 60181 County: DuPage

NPDES Storm Water General Permit Number: ILR10

Latitude: 41 53 9 Longitude: 87 58 14 10 39N 11E
(Deg) (Min) (Sec) (Deg) (Min) (Sec) Section Township Range

DATE PROJECT HAS BEEN COMPLETED AND STABILIZED: _____

NOTE: Coverage under this permit cannot be terminated without the completion date.

I certify under penalty of law that disturbed soils at the identified facility have been finally stabilized or that all storm water discharges associated with industrial activity from the identified facility that are authorized by an NPDES general permit have otherwise been eliminated. I understand that by submitting this notice of termination, that I am no longer authorized to discharge storm water associated with industrial activity by the general permit, and that discharging pollutants in storm water associated with industrial activity to Waters of the State is unlawful under the Environmental Protection Act and the Clean Water Act where the discharge is not authorized by an NPDES Permit.

Any person who knowingly makes a false, fictitious, or fraudulent material statement, orally or in writing, to the Illinois EPA commits a Class 4 felony. A second or subsequent offense after conviction is a Class 3 felony. (415 ILCS 5/44(h))

Owner Signature: _____

Date: _____

Mail completed form to: Illinois Environmental Protection Agency
Division of Water Pollution Control, Attn: Permit Section
1021 North Grand Avenue East
P.O. Box 19276
Springfield, Illinois 62794-9276

(Do not submit additional documentation unless requested)

This Agency is authorized to require this information under Section 4 and Title X of the Environmental Protection Act (415 ILCS 5/4, 5/39). Failure to disclose this information may result in: a civil penalty of not to exceed \$50,000 for the violation and an additional civil penalty of not to exceed \$10,000 for each day during which the violation continues (415 ILCS 5/42) and may also prevent this form from being processed and could result in your application being denied. This form has been approved by the Forms Management Center.

GUIDELINES FOR COMPLETION OF NOTICE OF TERMINATION (NOT) FORM

Please adhere to the following guidelines:

Submit original, electronic or facsimile copies. Facsimile and/or electronic copies should be followed-up with submission of an original signature copy as soon as possible.

Submit completed forms to:

Illinois Environmental Protection Agency
 Division of Water Pollution Control, Attn: Permit Section
 1021 North Grand Avenue East
 P.O. Box 19276
 Springfield, Illinois 62794-9276
 or call (217) 782-0610
 FAX: (217) 782-9891

Or submit electronically to: epa.constit10swppp@illinois.gov

Reports must be typed or printed legibly and signed.

NOTE: FACILITY LOCATION IS NOT NECESSARILY THE FACILITY MAILING ADDRESS, BUT SHOULD DESCRIBE WHERE THE FACILITY IS LOCATED.

Use the formats given in the following examples for correct form completion.

	Example	Format
Section	12	1 or 2 numerical digits
Township	12N	1 or 2 numerical digits followed by "N" or "S"
Range	12W	1 or 2 numerical digits followed by "E" or "W"

Final stabilization has occurred when:

- (a) all soil disturbing activities at the site have been completed;
- (b) a uniform perennial vegetative cover with a density of 70% of the native background vegetative cover for the area has been established on all unpaved areas not covered by permanent structures; or
- (c) equivalent permanent stabilization measures have been employed.



APPLICATION FOR HIGHWAY PERMIT

DuPage County Division of Transportation
421 N. County Farm Road Wheaton, IL 60187-2553
(630) 407-6900

DuPage County Office Use Only:

Application Tracking #: _____

Date Rec'd.: _____ Tech: _____

(PRINT CLEARLY OR TYPE ALL INFORMATION REQUESTED. INCOMPLETE APPLICATIONS WITHOUT AN ORIGINAL SIGNATURE FOR THE OWNER CONTACT WILL NOT BE ACCEPTED OR PROCESSED.)

UTILITY COMPANY W.O. OR U.T. #: _____

PART I. OWNER (OF PROJECT OR EVENT) INFORMATION:

Owner Name: Village of Villa Park		Owner Contact: Jeremie Lukowicz	
Address: 20 S. Ardmore Avenue		City/State/Zip: Villa Park, IL 60181	
Phone: (630) 834-8505	Fax: (630) 834-8509	E-mail: jlukowicz@invillapark.com	
24 hour emergency #: (630) 834-7447		Website: www.invillapark.com	

PART II. PROJECT/EVENT LOCATION:

Property Address (if applicable): South of 211 S. Euclid Avenue		Site City: Village of Villa Park
County Route #: IL Prairie Path 47	County Route Name: IL Prairie Path - Main Stem	
Location to nearest cross street:	Southeast corner of Central Boulevard and Euclid Avenue	

PART III. PERMIT TYPE(S): (Check, circle and complete information, as is applicable to your project.)

A. ACCESS	C. TRAFFIC CONTROL/SIGNAGE
<input type="checkbox"/> Temporary construction entrance (not at permanent entrance)	<input type="checkbox"/> Temp road closure/detour [Total _____ day(s)]
<input type="checkbox"/> New residential entrance (or 2 nd entrance) (single family)	<input type="checkbox"/> Daily lane closures (9 am – 4 pm Mon - Fri) [Total _____ day(s)]
<input type="checkbox"/> New commercial, multi-family and/or side street connection	<input type="checkbox"/> Lane closures (between 12 am to 9 am and/or 4 pm to 12 am) [Total _____ day(s)]
<input type="checkbox"/> Left and/or right turn lane	<input type="checkbox"/> Municipal, subdivision entry or memorial signage
<input type="checkbox"/> Intersection maint - Signalized (resurface, repair or modify)	D. LANDSCAPING
<input type="checkbox"/> Intersection maint -Non-signalized (resurface, repair, or modify)	<input type="checkbox"/> Parkway, median trees, plantings and/or irrigation system
<input type="checkbox"/> Existing single-family entrance revision (repair, replace, modify and/or remove)	<input type="checkbox"/> Paths and/or walks (new, remove and/or replace)
<input type="checkbox"/> Existing commercial/multi-family entrance revisions, modify and/or removal	<input type="checkbox"/> Benches, fountains, garbage cans, kiosks, etc. (public use)
B. UTILITIES	<input type="checkbox"/> Fence, guardrail, railing
<input type="checkbox"/> Residential and/or commercial service connections (storm, sump pump/downspout, sanitary, water, gas, electric and/or telecommunication) – (New, repair, replace, modify and/or remove)	<input checked="" type="checkbox"/> Grading, topsoil, seed or sod installation
<input type="checkbox"/> Mainline underground (non-pavement, open-cut trench method) (New, repair, replace, modify and/or remove)	E. PAVEMENT OPEN-CUTS
<input type="checkbox"/> Mainline underground (directional bore method) – (New, repair, replace, modify and/or remove)	<input type="checkbox"/> Number of cuts (_____)
<input type="checkbox"/> Underground utility (in existing ducts) - (New, replace and/or remove)	<input type="checkbox"/> Sizes (Surface area = ft ²) (_____)
<input type="checkbox"/> Mainline aerial (on existing poles) – (New, repair, replace, modify and/or remove)	F. SIGNALS/LIGHTING
<input type="checkbox"/> Utility structures (pole, manhole, hydrant, etc.) – (New, repair, replace, modify and/or remove)	<input type="checkbox"/> Existing signal equipment revision/addition
<input type="checkbox"/> Storm sewer (mainline, taps and/or structures) – (New, repair, replace, modify and/or remove)	<input type="checkbox"/> New traffic signals/ equipment/ interconnection
<input type="checkbox"/> Emergency mainline, service and/or structure repair(s) (leaks or breaks only)	<input type="checkbox"/> Temporary signals/equipment
<input type="checkbox"/> Relocation and/or adjustments of existing facilities (due to government agency project)	<input type="checkbox"/> Street and/or path lighting and/or luminaires
	G. MISC.
	<input type="checkbox"/> Soil borings/monitoring wells Total _____
	<input type="checkbox"/> Special Event – highway or trail – [Run, walk, parade, scouting, school, church, Rugaard Gazebo use (Villa Park)]
	H. ADMINISTRATIVE
	<input type="checkbox"/> Violation (Red tag compliance)
	<input type="checkbox"/> Fine(s) (Compliance)
	<input type="checkbox"/> Extend permit (6 month) <input type="checkbox"/> Extend permit (12 month)
	<input type="checkbox"/> Transfer ownership Permit/App (from # _____)
	<input type="checkbox"/> Regulatory, informational and/or warning signage

NOT FOR BID



APPLICATION FOR HIGHWAY PERMIT

DuPage County Division of Transportation
421 N. County Farm Road Wheaton, IL 60187-2553
(630) 407-6900

DuPage County Office Use Only:

Application Tracking #: _____

Date Rec'd.: _____ Tech: _____

PART IV. GENERAL CONTRACTOR INFORMATION: (Complete all information, as is applicable.)

General:	Name: _____	Contact: _____
Address: _____	City/State/Zip: _____	
Phone: _____	Fax: _____	E-mail: _____
24 hour emergency # (type/number): _____		Website: _____

IT IS HEREBY UNDERSTOOD BY THE UNDERSIGNED THAT UNDER PENALTY OF INTENTIONAL MISREPRESENTATION AND/OR PERJURY, I declare that I have examined and/or made the application and it is true and correct to the best of my knowledge and belief. I agree to construct said improvement(s) or perform said event(s) according to and with all provisions of the Ordinances of the County of DuPage and any and all local, state and federal statutes and/or codes. I realize that the information that I have affirmed hereon forms a basis for the issuance of the Highway Permit herein applied for and approval of plans and specifications or event information submitted without variation unless prior written approval is obtained from the County Engineer in connection therewith. Approval shall not be construed to permit any construction upon or within said County rights-of-way or use thereof in violation of any provision of any Ordinance of the County of DuPage or to excuse the owner or his/her successors and assigns from complying therewith.

NOTICE: THIS APPLICATION IS NOT A PERMIT AND IN NO WAY AUTHORIZES THE APPLICANT OR CONTRACTOR TO CONSTRUCT/PERFORM ANY WORK OR HOLD AN EVENT WITHIN THE COUNTY'S HIGHWAY AND/OR TRAIL RIGHTS-OF-WAY WITHOUT THE ISSUANCE OF A COUNTY HIGHWAY PERMIT. COMMENCEMENT OF CONSTRUCTION/EVENT WITHOUT ISSUANCE OF A HIGHWAY PERMIT SHALL BE PROSECUTED TO THE FULL EXTENT OF APPLICABLE LAWS UNDER COUNTY ORDINANCE.

OWNER CONTACT SIGNATURE

(REQUIRED): _____

Date: _____

Applicant Contact Signature
(if different than Owner Contact): _____

Date: _____

***ALL FEES SHALL BE MADE PAYABLE TO THE "DUPAGE COUNTY DIVISION OF TRANSPORTION".**

DuPage County DOT Office Use Only

PAYMENT INFORMATION:

<u>APPLICATION FEE:</u> \$ _____	<u>VIOLATION FEE:</u> \$ _____	<u>TOTAL APPLICATION FEES:</u> \$ _____	
Type payment: _____	Check/receipt #: _____	Date: _____	By: _____
<u>PERMIT FEES:</u> _____	(See Calculation Sheet attached): \$ _____		
Type payment: _____	Check/receipt #: _____	Date: _____	By: _____
<u>ADDITIONAL FEES:</u> _____	(See 'REVISED' Calculation Sheet attached): \$ _____		
Type payment: _____	Check/receipt #: _____	Date: _____	By: _____

NOT FOR BID



DuPage County Division of Transportation

421 N. County Farm Road Wheaton, IL 60187-2553

630/407-6900 (Fax) 630/407-6901

ADDITIONAL ITEMS REQUIRED:

Additional items may be required by the Division of Transportation following final approval of the engineering or site plan prior to the issuance of the permit, as follows:

1. **HIGHWAY PERMIT BOND:** The general contractor/owner shall provide a performance bond in the amount of 110% of the contract price of all work performed within the County's rights-of-way (or a minimum of \$1500.00 for single-family residential or \$2500.00 for multi-family or commercial, whichever is greater). An Engineer's Probable Cost Estimate or the contractor's contract quantity costs shall accompany the bond confirming the bond amount. The bond shall be either:
 - a. A Letter of Credit (per the County sample attached) or
 - b. A cashier's or certified check (made payable to the "DuPage County Division of Transportation"). Personal or business checks are NOT acceptable and will be returned.
2. **INSURANCE:** The general contractor shall provide a Certificate of Insurance, naming the "County of DuPage" as additional insured and "County of DuPage c/o Division of Transportation" as Certificate Holder, based upon the requirements of Art. 107.27 of IDOT's "Standard Specifications for Road and Bridge Construction" (latest edition) for said project per the attached information and sample certificate. The description of the certificate should include the note; "The Certificate Holder is named as additional insured with respect to general and automobile liability for all work performed within DuPage County rights-of-way". In addition, the following items are required:
 - A. General and Automobile liability endorsements naming the "County of DuPage, its successors, assigns & employees" as an additional insured to the policy; and
 - B. Cancellation/non-renewal endorsements for general and automobile liability stating the "County of DuPage c/o Division of Transportation" will be notified if such policy is cancelled. If the cancellation riders cannot be provided, the insured can provide a cancellation notice guarantee to the County per the attached sample (on the insured's letterhead); and
 - C. Aggregate amounts of the policy shall be: "Per Occurrence" shall total \$2M and combined "General Aggregate" needs to total \$4M or a combination of General Aggregate and Excess/Umbrella liability needs to meet the required aggregate amount;
 - D. Proof of Workers Compensation coverage on Certificate of Insurance only; and
 - E. For engineering and architectural firms, include Professional Liability coverage in the aggregate amounts of \$1M per occurrence and \$2M aggregate.
 - F. Policy numbers must be identified on all pages of the policy and coincide with the Certificate of Insurance.
3. **IMPACT FEE RECEIPT:** Any proposed construction (new or improvement) within the County's highway rights-of-way requires the provision of proof of payment and compliance with the County's Roadway Impact Fee Ordinance for the site building construction.
4. **SPECIAL EVENT COVER LETTER, FLYER, WAIVER and ROUTE MAP:** Provide a cover letter detailing the date, time (including event start/finish time and needed set-up/clean-up time), copy of the special event flyer (including the waiver) and a route/location map (if applicable). The event waiver shall include the statement; "The County of DuPage, its successors, assigns and employees shall be held harmless for any injury to persons and/or damage to property for participating in said event" along with any other applicable agencies or groups necessary for the requested event.
5. **SPECIAL EVENT MINOR RELEASE:** A parent or legal guardian must sign a release for any minors (under 18 years of age) participating in a scouting or school sponsored event (outside of an organized race or event covered by the standard event flyer/waiver required previously in Item #4).

107.27 Insurance. The Contractor shall obtain and thereafter keep in force the following insurance coverages provided by insurance companies acceptable to the Department and authorized to transact business under the laws of the State of Illinois. The insurance companies providing coverage shall be rated in the Best's Key Rating Guide. The Department will accept companies with a rating not lower than B+ provided the financial size category is VII or larger. Companies rated A- or better shall have a financial size category of not less than VI. Coverage limits shall be written at not less than the minimum specified in this Article. Higher minimum limits and additional coverage may be specified by a special provision elsewhere in the contract. Whether stated in this Article or elsewhere, the Department does not warrant the adequacy of the types of insurance coverage or the limits of liability specified.

(a) Workers Compensation and Employers Liability.

Legal Regulations and Responsibility To Public Art. 107.27

(1) Workers compensation shall be provided according to the provisions of the Illinois Worker's Compensation Act, as amended. Notwithstanding the rating and financial size categories stated in this Article, coverage may be provided by a group self-insurer authorized in Section 4(a) of the Act and approved pursuant to the rules of the Illinois Department of Insurance.

(2) Employers Liability.

- a. Each Accident \$500,000
- b. Disease-policy limit \$500,000
- c. Disease-each employee \$500,000

(b) Commercial General Liability. Required liability insurance coverage shall be written in the occurrence form and shall provide coverage for operations of the Contractor; operations of subcontractors (contingent or protective liability); completed operations; broad form property damage and hazards of explosion, collapse and underground; and contractual liability. The general aggregate limit shall be endorsed on a per project basis.

- (1) General Aggregate Limit \$2,000,000
- (2) Products-Completed Operations
Aggregate Limit \$2,000,000
- (3) Each Occurrence Limit \$1,000,000

The coverage shall provide by an endorsement in the appropriate manner and form, the Department, its officers, and employees shall be named as additional insureds with respect to the policies and any umbrella excess liability coverage for occurrences arising in whole or in part out of the work and operations performed. The Department may accept a separate owner's protective liability policy in lieu of the Department, it's officers, and employees being insureds on the Contractor's policies.

- (c) Commercial Automobile Liability. The policy shall cover owned, non-owned, and hired vehicles.

Bodily Injury & Property Damage Liability Limit Each Occurrence	\$1,000,000
--	-------------

- (d) Umbrella Liability. Any policy shall provide excess limits over and above the other insurance limits stated in this Article. The Contractor may purchase insurance for the full limits required or by a combination of primary policies for lesser limits and remaining limits provided by the umbrella policy.

All insurance shall remain in force during the period covering occurrences happening on or after the effective date and remain in effect during performance of the work and at all times thereafter when the Contractor may be correcting, removing, or replacing defective work until notification of the date of final inspection. Termination or refusal to renew shall not be made without 30 days prior written notice to the Department by the insurer and the policies shall be endorsed so as to remove any language restricting or limiting liability concerning this obligation.

Certified copies of the original policies or certificate(s) of insurance by the insurer(s) issuing the policies and endorsements setting forth the coverage, limits, and endorsements shall be filed with the Department before the Department will execute the contract. A certificate of insurance shall include a statement "the coverage and limits conform to the minimums required by Article 107.27 of the Standard Specifications for Road and Bridge Construction". Any exception or deviation shall be brought to the attention of the Department for a ruling of acceptability. In no event shall any failure of the Department to receive policies or certificates or to demand receipt be construed as a waiver of the Contractor's obligation to obtain and keep in force the required insurance.

All costs for insurance as specified herein will be considered as included in the cost of the contract. The Contractor shall, at his/her expense and risk of delay, cease operations if the insurance required is terminated or reduced below the required amounts of coverage. Coverage in the minimum amounts set forth herein shall not be construed to relieve the Contractor from his/her obligation to indemnify in excess of the coverage according to the contract.

(AGENT CONTACT INFO.)

(INSURANCE COMPANY INFORMATION)

DBS

Named Insured and Address

Policy Type: *Commercial Umbrella*

Reason Issued: *Renewal*
Policy Number: 123ABCDEF
Renewal of: 123ABCDEF
Issue Date: 05/29/12

JOHN SMITH'S PLUMBING, INC.
ON.000 MAIN STREET
ANYTOWN, IL USA 00000-0000

COMMERCIAL LIABILITY UMBRELLA DECLARATIONS

Policy Period: From 06/15/12 To 06/15/13 12:01 a.m. at the address of the Named Insured as shown above.

Form of Business: *CORPORATION*
Business Description: *CABLE TV INSTALL*

IN RETURN FOR THE PAYMENT OF PREMIUM, AND SUBJECT TO ALL THE TERMS OF THIS POLICY, WE AGREE WITH YOU TO PROVIDE THE INSURANCE STATED IN THIS POLICY.

Commercial Liability Umbrella Limits Of Insurance

- \$2,000,000 Each Occurrence Limit
- \$2,000,000 Personal and Advertising Injury Limit
- \$2,000,000 Aggregate Limit (except with respect to "covered autos")

Retained Limit

See Schedule of Underlying Insurance

None Self-Insured Retention applicable to each "occurrence" or offense which is covered by this insurance but not covered by "underlying insurance"

Advance Premium:

\$771.00

Certified Acts of Terrorism:

\$15.00

Your Estimated Total Policy Premium Is **\$786.00**

Premium does not include service charges.

THIS IS NOT A BILL. Any outstanding balance due will be billed at a later date.

THESE DECLARATIONS, TOGETHER WITH THE COMMON POLICY CONDITIONS, COVERAGE FORM(S), SCHEDULE(S) AND ANY ENDORSEMENT(S), COMPLETE THE ABOVE NUMBERED POLICY.

(INSURANCE COMPANY INFORMATION)

Endorsement

IL 03

Policy Number: ABC12345

Cancellation Privilege Notice

This endorsement changes the policy effective on the inception date of the policy unless another date is indicated below.

Endorsement effective 06/15/2012 AT 12:01 A.M. CENTRAL STANDARD TIME	
Named Insured JOHN SMITH'S PLUMBING, INC.	Countersigned by

(Authorized Representative)

SCHEDULE

Name and Address of Person or Organization to Receive Notice of Cancellation:

COUNTY OF DUPAGE c/o
the Division of Transportation
421 N. County Farm Road
Wheaton, IL 60187-2553

- A. If we cancel this policy, we will mail to the person or organization named in the Schedule of this endorsement, written notice of cancellation at least 30 days before the effective date of cancellation.
- B. If you cancel this policy, we will mail to the person or organization named in the Schedule of this endorsement, written notice of cancellation.

Endorsement

BP 133

Policy Number: ABC12345

**ADDITIONAL INSURED - OWNERS, LESSEES
OR CONTRACTORS - SCHEDULED PERSON
OR ORGANIZATION**

**THIS ENDORSEMENT CHANGES THE POLICY.
PLEASE READ IT CAREFULLY.**

This endorsement modifies insurance provided
under the following:

BUSINESSOWNERS COVERAGE FORM

SCHEDULE *

**Name Of Additional Insured Person(s) Or
Organization(s):**

COUNTY OF DUPAGE, it's officers and employees,
c/o the Division of Transportation
421 N. County Farm Road
Wheaton, IL 60187-2553

Location(s) Of Covered Operations:

Work performed within the DuPage

County rights-of-way.

*Information required to complete this Schedule,
will be shown in the Declarations.

The following is added to Paragraph C. **Who Is An
Insured in Section II - Liability:**

4. Any person(s) or organization(s) shown in the
Schedule is also an additional insured, but
only with respect to liability for "bodily
injury", "property damage" or "personal and
advertising injury" caused, in whole or in part,
by:

a. Your acts or omissions; or

b. The acts or omissions of those acting on your
behalf;

in the performance of your ongoing operations
for the additional insured(s) at the location(s)
designated above.

With respect to the insurance afforded to these
additional insureds, the following additional
exclusions apply:

This insurance does not apply to "bodily
injury" or "property damage" occurring after

a. All work, including materials, parts or
equipment furnished in connection with
such work, on the project (other than
service, maintenance or repairs) to be
performed by or on behalf of the additional
insured(s) at the location of the covered
operations has been completed; or

b. That portion of "your work" out of which
the injury or damage arises has been put to
its intended use by any person or
organization other than another contractor
or subcontractor engaged in performing
operations for a principal as a part of the
same project.

Includes copyrighted material of Insurance Services Office, Inc., with its permission.

Contractor's Letterhead

Date: _____

Mr. Christopher C. Snyder, P.E.
County Engineer
DuPage County Division of Transportation
421 N. County Farm Road
Wheaton, IL 60187-2553
(630) 407-6900 – Phone
(630) 407-6901 - Fax

Re: **Insurance Acknowledgment/Agreement**

Dear Mr. Snyder:

As the authorized signatory of (Name of Organization), (Name of Representative) agrees as follows:

(Name of Representative) will immediately notify the County of DuPage through the Division of Transportation (County) if any insurance required under the above referenced highway permit application has been cancelled, materially changed, or renewal has been refused, and (Name of Organization) shall immediately suspend all work in progress and take the necessary steps to purchase, maintain and provide the required insurance coverage. If a suspension of work should occur due to insurance requirements, upon verification by the County of the required insurance coverage, the County shall notify (Name of Representative) that (Name of Organization) can proceed with the work. Failure to provide and maintain the required insurance coverage could result in the immediate cancellation of the permit issued for the work and Name of Organization shall accept and bear all costs that may result due to (Name of Organization)'s failure to provide and maintain the required insurance.

Very truly yours,

Name: (Signature)

Name: (Print)

Title:

CENTRAL BOULEVARD IMPROVEMENTS
VILLAGE OF VILLA PARK

APPENDIX 5

GEOTECHNICAL REPORT
LPC 662 CCDD CERTIFICATION (STREET NAMES)
LPC 663 CCDD CERTIFICATION (STREET NAMES)
BLUFF CITY MATERIALS PRE APPROVAL LETTER

NOT FOR BID

NOT FOR BID



REPORT TRANSMITTAL

October 7th, 2016

To: Yann Gallin
RJN Group
200 W. Front St.
Wheaton, IL 60187
Phone: 630.682.4700 x 320
Fax: 630.682.4754

Re: **Geotechnical Engineering Services Report**
Proposed Sewer Separation and Road
Reconstruction
Various Streets
Villa Park, Illinois

Rubino Report No. G16.124

Via email: ygallin@rjnmail.com

Dear Mr. Gallin,

Rubino Engineering, Inc. (Rubino) is pleased to submit our Geotechnical Engineering Services Report for the proposed Sewer Separation and Road Reconstruction in Villa Park, Illinois.

Report Description

Enclosed is the Geotechnical Services Report including results of field and laboratory testing, as well as recommendations for pavement design and general site development.

Authorization and Correspondence History

- Rubino Proposal No. Q16.035g dated January 27th, 2016; Signed and authorized by the Subconsultant Agreement between RJN Group and Rubino Engineering, Inc. on August 22nd, 2016.

Closing

Rubino appreciates the opportunity to provide geotechnical services for this project and we look forward to continued participation during the design and in future construction phases of this project.

If you have questions pertaining to this report, or if Rubino may be of further service, please contact our office at (847) 931-1555.

Respectfully submitted,
RUBINO ENGINEERING, INC.

Michelle A. Lipinski, PE
President

michelle.lipinski@rubinoeng.com

MAL/file/ Enclosures

NOT FOR BID

**PROPOSED SEWER SEPARATION AND
ROAD RECONSTRUCTION**

VILLA PARK, ILLINOIS

RUBINO PROJECT No. G16.124

***Geotechnical
Services
Report***

*Drilling
Laboratory Testing
Geotechnical Analysis*

PREPARED BY:

rubino
ENGINEERING INC.

**Michelle A. Lipinski, PE
President
IL No. 062-061241, Exp. 11/30/17**

PREPARED FOR:

**RJN GROUP
200 W. FRONT ST.
WHEATON, ILLINOIS**

OCTOBER 7TH, 2016

NOT FOR BID

TABLE OF CONTENTS

PROJECT INFORMATION	- 1 -
<i>Table 1: Drilling Scope</i>	- 1 -
<i>Table 2: Coring & Hand Auger Scope</i>	- 2 -
DRILLING, FIELD, AND LABORATORY TEST PROCEDURES	- 2 -
SITE AND SUBSURFACE CONDITIONS	- 3 -
SITE LOCATION AND DESCRIPTION	- 3 -
SURFACE CONDITIONS.....	- 5 -
<i>Table 3: Existing Pavement Section Summary</i>	- 5 -
SUBSURFACE CONDITIONS.....	- 11 -
<i>Table 4: Subsurface Conditions Summary</i>	- 11 -
GROUNDWATER CONDITIONS	- 12 -
EVALUATION AND RECOMMENDATIONS	- 12 -
GEOTECHNICAL CONSIDERATIONS.....	- 12 -
DEWATERING RECOMMENDATIONS.....	- 13 -
ORGANIC SOILS DISCUSSION	- 13 -
<i>Table 5: Organic Content by Location</i>	- 13 -
SITE PREPARATION & FILL RECOMMENDATIONS.....	- 14 -
TRENCH BOX & LATERAL EARTH PRESSURE RECOMMENDATIONS	- 14 -
<i>Table 6: "At-rest" Lateral Earth Pressures</i>	- 14 -
UTILITY TRENCH BACKFILL RECOMMENDATIONS	- 15 -
TRENCHLESS CONSTRUCTION - HDD	- 16 -
PAVEMENT SUBGRADE PREPARATION AND TESTING	- 16 -
SUBGRADE STABILITY RECOMMENDATIONS	- 17 -
<i>Table 7: Subgrade Stability Recommendations</i>	- 17 -
IBV BASED REMEDIAL ACTION CHART – IDOT.....	- 19 -
ROADWAY DRAINAGE AND MAINTENANCE	- 20 -
CLOSING	- 20 -
APPENDIX A - DRILLING, FIELD, AND LABORATORY TEST PROCEDURES	
APPENDIX B – REPORT LIMITATIONS	
APPENDIX C – SOIL CLASSIFICATION GENERAL NOTES	
APPENDIX D – SOIL CLASSIFICATION CHART	
APPENDIX E – SITE VICINITY MAP & BORING/CORING LOCATION PLAN	
APPENDIX F – BORING LOGS	
APPENDIX G – LABORATORY TESTS	

NOT FOR BID

PROJECT INFORMATION

Rubino understands that the Village of Villa Park is planning a sanitary sewer separation and road reconstruction on Central Boulevard, Myrtle Avenue, Cortesi Avenue, Crescent Drive, and Astor Court in Villa Park, Illinois.

Site Grading and Pavement Design Criteria were not received but are based on the following:

- The storm sewer bearing no deeper than 8 feet below existing grade
- Site grading including cuts and fills being less than 2 feet
- Light Duty Pavement 18-kip ESALS: 30,000
- Heavy Duty Pavement 18-kip ESALS: 60,000
- Pavement Life Expectancy: 15 years

Documents received:

- “Soil Boring Locations” – Prepared by RJN Group dated January 2016.
- “Myrtle Ave Sanitary Sewer Separation” – Prepared by RJN Group dated January 2016.

Project Correspondence:

- RFP Email from Yann Gallin of RJN Group on January 27th, 2016.

The geotechnical recommendations presented in this report are based on the available project information, given boring locations, and the subsurface materials described in this report. If any of the information on which this report is based is incorrect, please inform Rubino in writing so that we may amend the recommendations presented in this report (if appropriate, and if desired by the client). Rubino will not be responsible for the implementation of our recommendations if we are not notified of changes in the project.

The purpose of this study was to explore the subsurface conditions at the site in order to prepare geotechnical recommendations for the proposed construction.

Rubino’s scope of services included the following drilling program:

Table 1: Drilling Scope

NUMBER OF BORINGS	DEPTH (FEET BEG*)	LOCATION
1	15	Central Boulevard and Cortesi Avenue
1	15	Myrtle Avenue and Crescent Drive
1	15	Myrtle Avenue and Astor Court
1	15	Myrtle Avenue and E Highland Avenue



NUMBER OF BORINGS	DEPTH (FEET BEG*)	LOCATION
1	15	Astor Court
1	15	Crescent Drive

*BEG = below existing grade

Table 2: Coring & Hand Auger Scope

NUMBER OF CORES	IBV TESTING METHOD	HAND AUGER DEPTH (FEET BEG*)	LOCATION
6	DCP	5 feet	Myrtle Avenue
4	DCP	5 feet	Astor Court
2	DCP	5 feet	Crescent Drive
4	DCP	5 feet	Central Boulevard
2	DCP	5 feet	Cortesi Avenue

Representative soil samples obtained during the field exploration program were transported to the laboratory for additional classification and laboratory testing.

This report briefly outlines the following:

- Summary of client-provided project information and report basis
- Overview of encountered subsurface conditions
- Overview of field and laboratory tests performed including results
- Geotechnical recommendations pertaining to:
 - Subgrade preparation and stability recommendations
 - Lateral earth pressures for trench box design
- Construction considerations, including temporary excavation and construction control of water.

DRILLING, FIELD, AND LABORATORY TEST PROCEDURES

RJN Group selected the number of cores, borings, and the boring depths. Rubino located the cores in the field by using a Garmin GPSMAP 64s.

The borings were advanced utilizing 3 ¼ inch inside-diameter, hollow stem auger drilling methods and soil samples were routinely obtained during the drilling process.

The pavement cores were performed with a Milwaukee Drill and Diamond-bit core barrel.



Dynamic Cone Penetrometer testing was performed in accordance with ASTM D6951 and soil samples were obtained from hand auger sampling to the depths indicated herein.

Selected soil samples were tested in the laboratory to determine material properties for this report. Field and laboratory testing was accomplished in general accordance with ASTM or IL Modified AASHTO procedures, as applicable. The following items are further described in the Appendix of this report.

- *Field Penetration Tests and Split-Barrel Sampling of Soils*
- *Dynamic Cone Penetrometer (DCP) Testing (ASTM D6951)*
- *Field Water Level Measurements*
- *Laboratory Determination of Water (Moisture) Content of Soil by Mass (ASTM D2216)*
- *Laboratory Determination of Atterberg Limits (ASTM D4318)*
- *Laboratory Organic Content by Loss on Ignition (ASTM D2974)*

The laboratory testing program was conducted in general accordance with applicable ASTM specifications. The results of these tests are to be found on the accompanying boring logs located in the Appendix.

SITE AND SUBSURFACE CONDITIONS

Site Location and Description

The general site location of exploration included Central Boulevard, Myrtle Avenue, Cortesi Avenue, Crescent Drive, and Astor Court in Villa Park, Illinois.

Central Boulevard from Summit Avenue to Villa Avenue:

- Western Project Limit Latitude / Longitude: 41° 53' 05.78"N / 87° 58' 26.32"W
- Eastern Project Limit Latitude / Longitude: 41° 53' 09.93"N / 87° 58' 08.89"W

Crescent Drive from Myrtle Avenue to Villa Avenue:

- Western Project Limit Latitude / Longitude: 41° 53' 05.45"N / 87° 58' 13.37"W
- Eastern Project Limit Latitude / Longitude: 41° 53' 06.14"N / 87° 58' 08.88"W

Astor Court from Summit Avenue to Myrtle Avenue:

- Western Project Limit Latitude / Longitude: 41° 53' 01.53"N / 87° 58' 26.57"W
- Eastern Project Limit Latitude / Longitude: 41° 53' 01.66"N / 87° 58' 13.37"W

Myrtle Avenue from Central Boulevard to Kenilworth Avenue:

- Northern Project Limit Latitude / Longitude: 41° 53' 11.82"N / 87° 58' 14.76"W
- Southern Project Limit Latitude / Longitude: 41° 53' 08.65"N / 87° 58' 14.69"W



Myrtle Avenue from Park Boulevard to Highland Avenue:

- Northern Project Limit Latitude / Longitude: 41° 53' 07.44"N / 87° 58' 13.42"W
- Sothern Project Limit Latitude / Longitude: 41° 52' 57.30"N / 87° 58' 13.30"W

Cortesi Avenue from Central Boulevard to Kenilworth Avenue:

- Northern Project Limit Latitude / Longitude: 41° 53' 11.81"N / 87° 58' 12.23"W
- Sothern Project Limit Latitude / Longitude: 41° 53' 09.25"N / 87° 58' 12.22"W













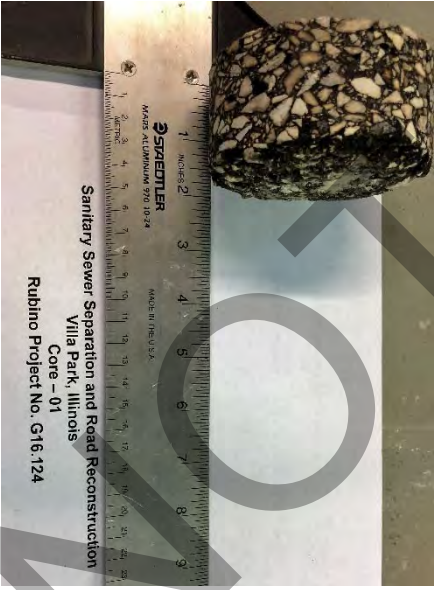



The soil borings were taken within the existing pavement and the map below shows the general site location:













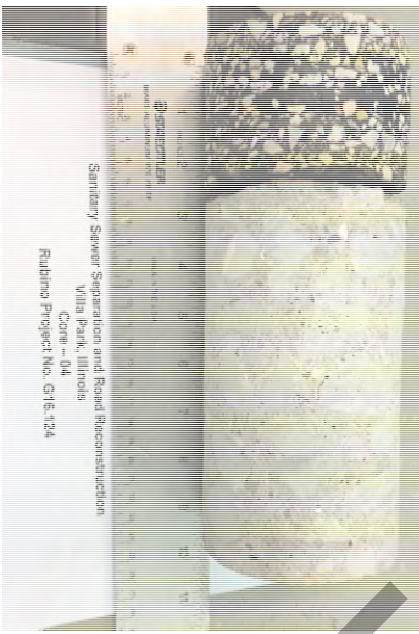
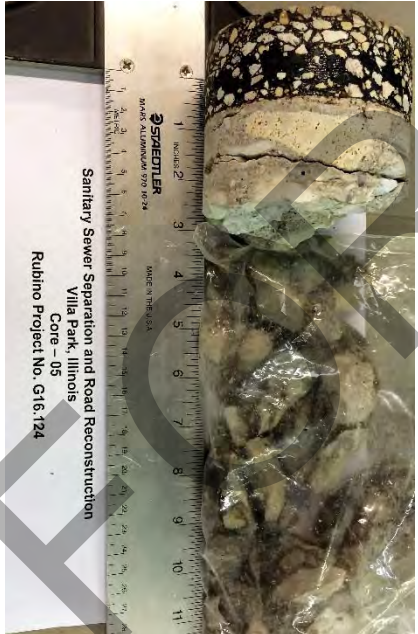
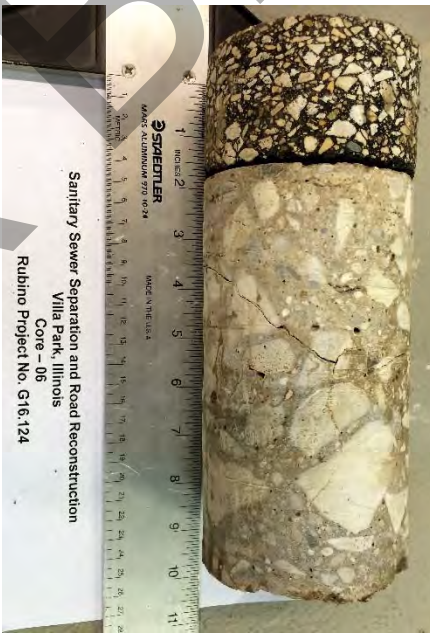

Surface Conditions

The cores were performed within the existing pavement and the surface conditions generally consisted of the following:



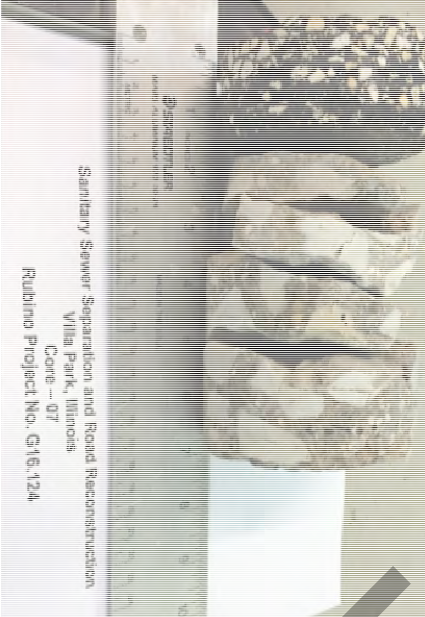

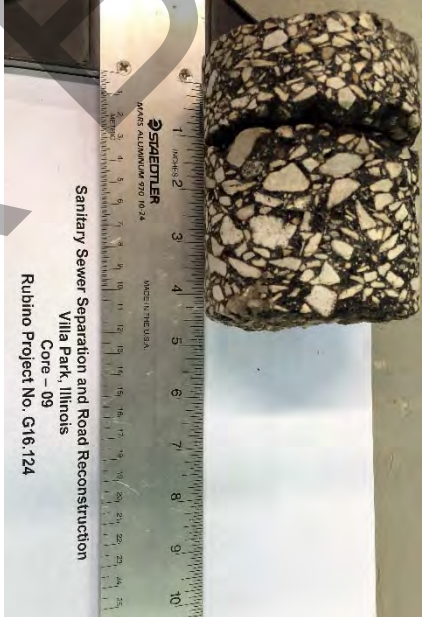







Table 3: Existing Pavement Section Summary

Core # 1 (Cortesi Avenue)	Core # 2 (Cortesi Avenue)	Core # 3 (Myrtle Avenue)
 <p>Picture facing North</p>	 <p>Picture facing North</p>	 <p>Picture facing North</p>
 <p>Sanitary Sewer Separation and Road Reconstruction Villa Park, Illinois Core - 01 Rubino Project No. G16.124</p>	 <p>Sanitary Sewer Separation and Road Reconstruction Villa Park, Illinois Core - 02 Rubino Project No. G16.124</p>	 <p>Sanitary Sewer Separation and Road Reconstruction Villa Park, Illinois Core - 03 Rubino Project No. G16.124</p>
<p><u>Total Thickness = 8 inches</u></p> <ul style="list-style-type: none">  HMA Surface₁ = 2 in.  Concrete = 6 in. Deteriorated  Subbase Stone Not Observed 	<p><u>Total Thickness = 9 inches</u></p> <ul style="list-style-type: none">  HMA Surface₁ = 1 ½ in.  HMA Surface₂ = ¾ in.  Concrete = 6 ¾ in.  Subbase Stone Not Observed 	<p><u>Total Thickness = 9 inches</u></p> <ul style="list-style-type: none">  HMA Surface₁ = 1 in.  HMA Surface₂ = ½ in.  Concrete = 7 ½ in.  Subbase Stone Not Observed











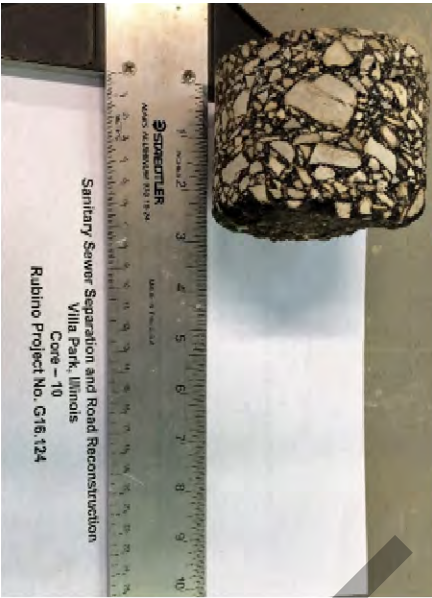

Core # 4 (Myrtle Avenue)	Core # 5 (Central Boulevard)	Core # 6 (Central Boulevard)
 <p>Picture facing South</p>	 <p>Picture facing West</p>	 <p>Picture facing West</p>
		
<p><u>Total Thickness = 9 ½ inches</u></p> <ul style="list-style-type: none">  HMA Surface₁ = 1 ¼ in.  HMA Surface₂ = 1 ¼ in.  Concrete = 7 in. <p>Subbase Stone Not Observed</p>	<p><u>Total Thickness = 9 inches</u></p> <ul style="list-style-type: none">  HMA Surface₁ = 1 in.  HMA Surface₂ = ½ in.  Concrete = 7 ½ in. Deteriorated <p>Subbase Stone Not Observed</p>	<p><u>Total Thickness = 9 inches</u></p> <ul style="list-style-type: none">  HMA Surface₁ = 1 ¼ in.  HMA Surface₂ = ¾ in.  Concrete = 7 in. <p>Subbase Stone Not Observed</p>

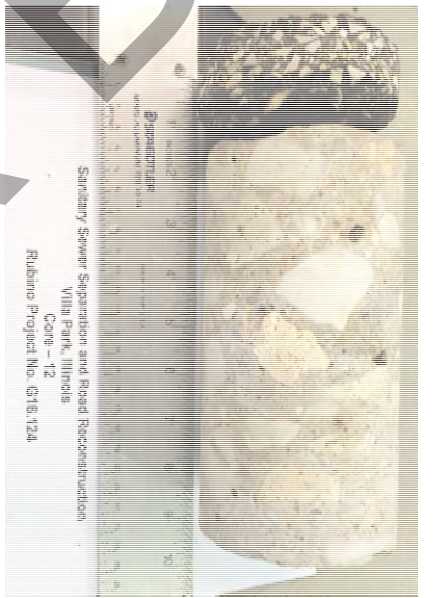

Core # 7 (Central Boulevard)	Core # 8 (Central Boulevard)	Core # 9 (Crescent Drive)
 <p>Picture facing West</p>	 <p>Picture facing West</p>	 <p>Picture facing East</p>
 <p>Sanitary Sewer Separation and Road Reconstruction Villa Park, Illinois Core -- 07 Rubino Project No. G16.124</p>	 <p>Sanitary Sewer Separation and Road Reconstruction Villa Park, Illinois Core -- 08 Rubino Project No. G16.124</p>	 <p>Sanitary Sewer Separation and Road Reconstruction Villa Park, Illinois Core -- 09 Rubino Project No. G16.124</p>
<p>Total Thickness = 10 inches</p> <ul style="list-style-type: none">  HMA Surface₁ = 1 in.  HMA Surface₂ = 1/2 in.  Concrete = 8 1/2 in. Deteriorated <p>Subbase Stone Not Observed</p>	<p>Total Thickness = 9 1/2 inches</p> <ul style="list-style-type: none">  HMA Surface₁ = 1 1/2 in.  Concrete = 8 in. <p>Subbase Stone Not Observed</p>	<p>Total Thickness = 4 1/2 inches</p> <ul style="list-style-type: none">  HMA Surface₁ = 1 1/2 in.  HMA Binder₁ = 3 in. <p>Subbase Stone = 4 1/2 inches</p>











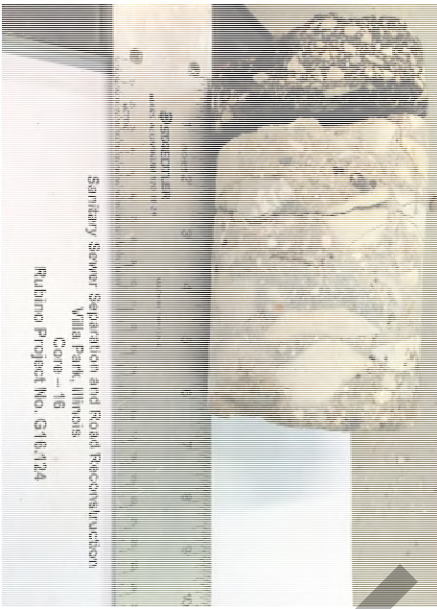
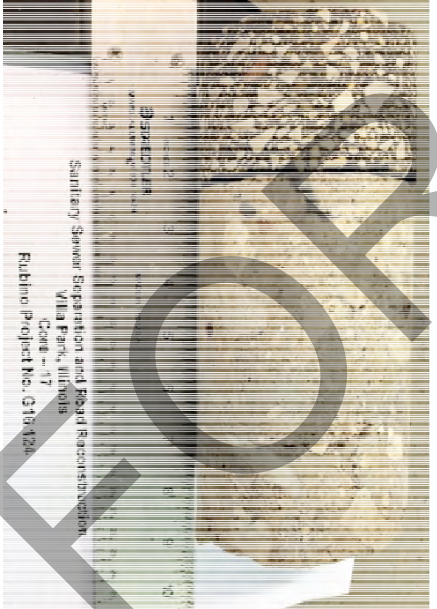
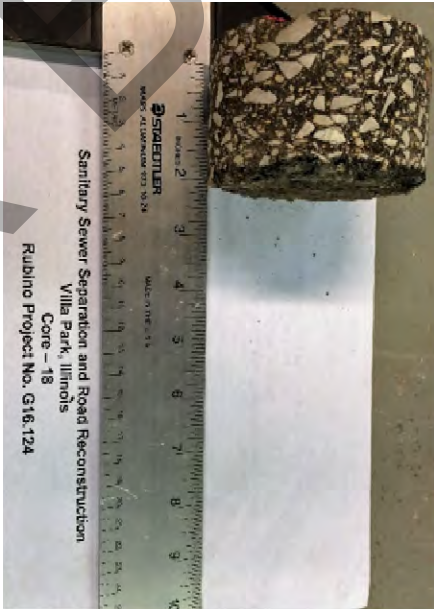

Core # 10 (Crescent Drive)	Core # 11 (Myrtle Avenue)	Core # 12 (Myrtle Avenue)
 <p data-bbox="170 592 440 625">Picture facing East</p>	 <p data-bbox="669 592 951 625">Picture facing North</p>	 <p data-bbox="1175 592 1458 625">Picture facing West</p>
		
<p data-bbox="102 1304 508 1337">Total Thickness = 3 inches</p> <ul style="list-style-type: none"> <li data-bbox="66 1354 365 1386">  HMA Surface₁ = 1 in. <li data-bbox="66 1390 354 1421">  HMA Binder₁ = 2 in. <li data-bbox="147 1428 459 1453"> Subbase Stone = 13 inches 	<p data-bbox="589 1304 1027 1337">Total Thickness = 8 ½ inches</p> <ul style="list-style-type: none"> <li data-bbox="570 1354 898 1386">  HMA Surface₁ = 1 ½ in. <li data-bbox="570 1390 816 1421">  Concrete = 7 in. <li data-bbox="630 1428 987 1453"> Subbase Stone = Not Observed 	<p data-bbox="1092 1304 1531 1337">Total Thickness = 8 ½ inches</p> <ul style="list-style-type: none"> <li data-bbox="1073 1354 1401 1386">  HMA Surface₁ = 1 ¼ in. <li data-bbox="1073 1390 1349 1421">  Concrete = 7 ¼ in. <li data-bbox="1133 1428 1490 1453"> Subbase Stone = Not Observed



<p>Core # 13 (Myrtle Avenue)</p>	<p>Core # 14 (Myrtle Avenue)</p>	<p>Core # 15 (Astor Court)</p>
 <p>Picture facing North</p>	 <p>Picture facing North</p>	 <p>Picture facing West</p>
 <p>Sanitary Sewer Separation and Road Reconstruction Villa Park, Illinois Core - 13 Rubino Project No. G16.124</p>	 <p>Sanitary Sewer Separation and Road Reconstruction Villa Park, Illinois Core - 14 Rubino Project No. G16.124</p>	 <p>Sanitary Sewer Separation and Road Reconstruction Villa Park, Illinois Core - 15 Rubino Project No. G16.124</p>
<p><u>Total Thickness = 8 ½ inches</u></p> <ul style="list-style-type: none">  HMA Surface₁ = 1 ¼ in.  Concrete = 7 ¼ in. <p>Subbase Stone Not Observed</p>	<p><u>Total Thickness = 11 inches</u></p> <ul style="list-style-type: none">  HMA Surface₁ = 1 ¾ in.  Concrete = 9 ¼ in. <p>Subbase Stone Not Observed</p>	<p><u>Total Thickness = 8 ½ inches</u></p> <ul style="list-style-type: none">  HMA Surface₁ = 1 in.  HMA Surface₂ = 1 in.  Concrete = 6 ½ in. <p>Subbase Stone Not Observed</p>



Core # 16 (Astor Court)	Core # 17 (Astor Court)	Core # 18 (Astor Court)
 <p data-bbox="167 564 444 600">Picture facing West</p>	 <p data-bbox="669 564 946 600">Picture facing West</p>	 <p data-bbox="1177 564 1455 600">Picture facing West</p>
 <p data-bbox="115 898 185 1119">Sanitary Sewer Separation and Road Reconstruction Villa Park, Illinois Core - 16 Rubino Project No. G16.124</p>	 <p data-bbox="609 793 678 1098">Sanitary Sewer Separation and Road Reconstruction Villa Park, Illinois Core - 17 Rubino Project No. G16.124</p>	 <p data-bbox="1112 783 1182 1182">Sanitary Sewer Separation and Road Reconstruction Villa Park, Illinois Core - 18 Rubino Project No. G16.124</p>
<p data-bbox="100 1297 506 1333"><u>Total Thickness = 8 inches</u></p> <ul style="list-style-type: none"> <li data-bbox="66 1352 391 1381">  HMA Surface₁ = 1 ¼ in. <li data-bbox="66 1388 337 1417">  Concrete = 6 ¾ in. <li data-bbox="134 1423 472 1453">Subbase Stone Not Observed 	<p data-bbox="587 1283 1031 1318"><u>Total Thickness = 8 ½ inches</u></p> <ul style="list-style-type: none"> <li data-bbox="570 1337 898 1367">  HMA Surface₁ = 1 ½ in. <li data-bbox="570 1373 878 1402">  HMA Surface₂ = ¾ in. <li data-bbox="570 1409 842 1438">  Concrete = 6 ¼ in. <li data-bbox="639 1444 977 1474">Subbase Stone Not Observed 	<p data-bbox="1112 1283 1523 1318"><u>Total Thickness = 9 inches</u></p> <ul style="list-style-type: none"> <li data-bbox="1073 1337 1401 1367">  HMA Surface₁ = 1 ½ in. <li data-bbox="1073 1373 1377 1402">  HMA Surface₂ = 1 in. <li data-bbox="1073 1409 1503 1438">  Concrete = 6 ½ in. Deteriorated <li data-bbox="1143 1444 1481 1474">Subbase Stone Not Observed

The above referenced thicknesses are considered approximate and based on visual classifications. Pavement and sub-base type and thickness may vary between core locations.



Subsurface Conditions

Beneath the existing surficial pavement, subsurface conditions generally consisted of brown and gray, silty clay soils.

- The native **silty clay** soils were generally medium stiff to very stiff in consistency.

Table 4: Subsurface Conditions Summary

DEPTH RANGE (FT)	SOIL DESCRIPTION	SPT N-VALUES (BLOWS PER FOOT)	MOISTURE CONTENT (%)	ORGANIC CONTENT (%)	ESTIMATED SHEAR STRENGTH (PSF)
Proposed Sewer Separation					
1 - 3½	Stiff silty CLAY with organics (B-06)	9	28	10	1,200 – 1,300 psf
1 - 15	Medium stiff to very stiff silty CLAY	5 - 18	14 - 25	4 - 5	700 – 2,700 psf
DEPTH RANGE (FT)	SOIL DESCRIPTION	DCP VALUES (BLOWS PER 6 IN)	MOISTURE CONTENT (%)	ORGANIC CONTENT (%)	ATTERBERG LIMITS; LL / PL (%)
Proposed Road Reconstruction					
1 - 5	Silty CLAY	2 - 14	17 - 24	4 - 9	34 – 40 / 15 - 19
1 - 5	Silty CLAY with organics (C-06, C-07, C-08, C-11 & C-17)	2 - 16	19 - 25	10 - 12	36 – 46 / 19 - 23
1 - 5	Silty CLAY of high plasticity with organics (C-09)	3 - 11	33	26	58 / 33
1 - 5	Silty CLAY of medium to high plasticity with organics (C-13)	3 - 12	30	10	53 / 21
1 - 5	Silty CLAY of medium to high plasticity (C-15 & C-16)	2 - 14	20 - 22	8 - 9	54 – 61 / 20 - 22

The native soils were visually classified as silty clay (CL) according to the Unified Soil Classification System (USCS). The above table is a general summary of subsurface conditions. Please refer to the boring logs for more detailed information.

Estimated shear strength of clay soils is based on empirical correlations using N-values, moisture content, and unconfined compressive strength.



Groundwater Conditions

Groundwater was generally not observed to collect within the borings upon completion due to the low permeability of the encountered soils. Depending on the time of year, there is a possibility that perched groundwater could be encountered during excavation.

It should be noted that fluctuations in the groundwater level should be anticipated throughout the year depending on variations in climatological conditions and other factors not apparent at the time the borings were performed. Additionally, discontinuous zones of perched water may exist within the soils. The possibility of groundwater level fluctuation should be considered when developing the design and construction plans for the project.

EVALUATION AND RECOMMENDATIONS

Geotechnical Considerations

The main geotechnical design and construction considerations at this site are:

- **Subgrade soils** generally consisted of brown and gray silty clay. See Subsurface Conditions section for more detailed information.
 - Based on the DCP values, the IBV ranged between 3 – 7. See Subgrade Stability Discussion section for more detailed information.
 - **Expansive soils** (Liquid Limit >50%) were encountered in some of the borings. Expansive soils should be removed to a depth of at least 18 to 24 inches below the bottom of the proposed subbase stone thickness. See Subgrade Stability Discussion section for more detailed information.
 - **Organic soils** were observed within some of the borings. Organic soils should be removed and replaced with a compacted and documented engineered fill. See Organic Soils Discussion section for more detailed information.
 - Positive **drainage** of the subgrade soils combined with interceptor drains and positive surface drainage will help the life expectancy of the new pavement section. See the Pavement Drainage and Maintenance section for more detailed information.
- In general, the **asphalt thicknesses** ranged between 1 ¼ and 6 inches.
 - **Concrete** pavement was observed in some of the borings with thicknesses varying from 6 to 9 ¼ inches.
 - The **subbase stone** ranged between 4 ½ and 13 inches. See Subbase Stone recommendations section for more information.
- During subgrade preparation, Rubino recommends that one of our representatives be onsite for typical **observations and documentation** of proofrolling and penetrometer testing of the pavement subgrade.



The geotechnical-related recommendations in this report are presented based on the subsurface conditions encountered and Rubino's understanding of the project. Should changes in the project criteria occur, a review must be made by Rubino to determine if modifications to our recommendations will be necessary.

Dewatering Recommendations

Dewatering may be necessary during excavation of saturated soils due to presence of sand seams or other conditions not apparent at the time of drilling. Shoring or trench boxes may be required where the soils are saturated.

Organic Soils Discussion

Organic soils were observed within some of the borings during the drilling operations; however there is a possibility that organic soils could be encountered at other locations on the site.

The following table outlines areas where organic soils were observed to within the soil borings:

Table 5: Organic Content by Location

LOCATION	ORGANIC SOIL DEPTH RANGE (FT)	ORGANIC LOSS ON IGNITION (L.O.I.%)
Crescent Drive (B-06)	1 - 3½ ft.	10%
Central Boulevard (C-06)	1 – 5 ft.	10%
Central Boulevard (C-07)	1 – 5 ft.	11%
Central Boulevard (C-08)	1 – 5 ft.	10%
Crescent Drive (C-09)	1 – 5 ft.	26%
Myrtle Avenue (C-11)	1 – 5 ft.	12%
Myrtle Avenue (C-13)	1 – 5 ft.	10%
Astor Court (C-17)	1 – 5 ft.	10%

Organic soils can later cause settlement or stability problems. If encountered during construction, Rubino recommends that organic soils be removed and replaced with a compacted and documented engineered fill.



Site Preparation & Fill Recommendations

During construction, the site should be stripped of existing concrete, foundations, abandoned utilities, and pavement sections including asphalt, subbase, and curbs if applicable.

- Subgrade soils were classified as silty clay or clayey silt and based on laboratory testing, generally fall into the high to very high “frost susceptible” category.
- **Fine-grained soils** such as silts and clays are highly susceptible to moisture fluctuation and can become unstable when exposed to freeze/thaw cycles, additional moisture such as precipitation, and construction traffic.
- During subgrade preparation, Rubino recommends that one of our representatives be onsite for typical **observations and documentation** of proofrolling and penetrometer testing of the pavement subgrade, if applicable.

Please note that clay subgrade soils are sensitive to moisture and can be easily disturbed by precipitation, groundwater, or construction equipment. Therefore, extra care should be used to avoid disturbing these soils during construction activities.

Trench Box & Lateral Earth Pressure Recommendations

Excavation for trenches shall be performed in accordance with OSHA regulations as stated in 29 CFR Part 1926. According to the classifications methods of soils by this method, Rubino expects that the soils located at the proposed utilities would classify as Type C and Type B soils.

If trench boxes will be used throughout the installation of the utilities, lateral earth pressures should be considered for the excavations. Lateral earth pressures will be influenced by the conditions of wall or support restraint, methods of construction and/or compaction and the strength of the materials being restrained.

Lateral earth pressure is developed from the soils present within a wedge formed by the vertical below-grade lift station side and an imaginary line extending up and away from the bottom of the wall at an approximate 45° angle.

The lateral earth pressures are determined by multiplying the vertical applied pressure by the appropriate lateral earth pressure coefficient K . Rubino recommends designing the bracing for the temporary excavation for the utilities for the “at-rest” lateral earth pressure condition using K_0 .

The following table gives the “at-rest” lateral earth pressure for the soils encountered:

Table 6: “At-rest” Lateral Earth Pressures

SOIL TYPE	FRICTION ANGLE (DEG)	K_0
Silty Clay	28	0.53



Lateral earth pressure is developed from the soils present within a wedge formed by the vertical below-grade wall and an imaginary line extending up and away from the bottom of the wall at an approximate 45° angle.

Utility Trench Backfill Recommendations

In general, utility trench backfill materials should:

- Have a Standard Proctor maximum dry density greater than 100 pcf
- Be free of organic or other deleterious materials
- Have a maximum particle size no greater than 3 inches
- Be placed in maximum lifts of 6 inches of loose material and should include areas within the building and adjacent areas to a distance of at least 5 feet outside the building perimeters
- Each lift of compacted, engineered fill should be tested and documented by a representative of the geotechnical engineer prior to placement of subsequent lifts
- Soils classified as GP, GW, SP, and SW will generally be suitable for use as utility trench backfill.
 - If water must be added, it should be uniformly applied and thoroughly mixed into the soil
- Soils classified as CL, ML, SC, SM, OL, OH, MH, CH and PT should be considered unsuitable.

Structural fill added to the site shall be evaluated in accordance with the following table:

MATERIAL TESTED	PROCTOR TYPE* ¹	MIN % DRY DENSITY	PLACEMENT MOISTURE CONTENT RANGE	FREQUENCY OF TESTING* ²	MAXIMUM LOOSE LIFT HEIGHT
Utility Trench Backfill	Standard	95%	-2 to +2 %	1 per 50 LF of fill placed	6 inches

*¹ The test frequency for the laboratory reference shall be one laboratory Proctor \ test for each material used on the site. If the borrow or source of fill material changes, a new reference moisture/density test should be performed.

*²A minimum of one test per lift is recommended unless otherwise specified.

Tested fill materials that do not achieve either the required dry density or moisture content range shall be recorded, the location noted, and reported to the Contractor and Owner. A re-test of that area should be performed after the Contractor performs remedial measures. The above test frequencies should be discussed with the contractor prior to starting the work.

The geotechnical engineer of record can only certify work that was performed under their direct observation, or under the observation of a competent person under their specific direction.



Trenchless Construction - HDD

Based on the watermain extension being planned to be placed in the upper 8 feet from existing grade, Horizontal Directional Drilling appears to be an option for this project.

Horizontal Directional Drilling (HDD) is typically used when trenching or open excavation is not practical, such as water crossings, road/railway crossings, or in other sensitive crossings.

HDD is compatible with a wide range of soil conditions. However, very loose, soft, squeezing, collapsible, or flowing soils that are not self-supporting and highly permeable, large-grained cohesionless soils and fractured rock are problematic for HDD. These problematic soils could present some difficulties related to bore stability, settlement, and inadvertent drilling fluid returns, depending on the type of soil.

Pavement Subgrade Preparation and Testing

During construction, the site should be stripped of existing concrete, foundations, abandoned utilities, and pavement sections including asphalt, subbase, and curbs if applicable.

Prior to paving, the prepared subgrade should be proofrolled using a loaded tandem axle dump truck or similar type of pneumatic tired equipment with a minimum gross weight of 9 tons per single axle.

- Localized soft areas identified should be repaired prior to paving.
- Moisture content of the subgrade should be maintained between -2% and +3% of the optimum at the time of paving.
- It may require rework when the subgrade is either desiccated or wet.

Based on the boring and DCP data, the soils may not pass a proofroll if exposed at the time of construction. Rubino recommends budgeting for 12 inches of undercuts.

Subgrade soils that fail a proofroll may be treated by:

- Remove the unstable soils and walk in consecutive layers of approximately 6 inches of 3-inch crushed stone placed on the subgrade until the voids of the 3-inch stone are filled with the soft soil.
- Remove and replace with additional CA-6 stone.
- Stockpiling the existing, uncontaminated subbase stone and scarifying and re-compacting the existing subgrade soil to at least 95% compaction per ASTM D698 Standard Proctor (12 inch depth).
- Lime or other chemical additive stabilization (12 to 14 inches).

A layer of geotextile should be placed between silty clay soil and an open-graded stone.



In conjunction with proper maintenance, removing unstable soils at the time of construction will extend the life of the pavement.

Areas of low support or soft spots should be tested with either a Static Cone Penetrometer (SCP) or Dynamic Cone Penetrometer (DCP). The results of the DCP or SCP tests should be evaluated according to IDOT’s Subgrade Stability Manual, to determine the necessary depth of corrective action.

Construction traffic should be minimized to prevent unnecessary disturbance of the pavement subgrade. Disturbed areas, as documented in the field by Rubino, should be treated as recommended below.

Subgrade Stability Recommendations

The recommendations located in this report are based on the data obtained at each particular soil boring location. Soil subgrade stability may vary in the field between the borings and could be affected by the weather at the time of construction.

- Subgrade with an IBV value of 5 or less is a candidate for remediation.
- Optional remedial activities are specified for subgrade with an IBV values between 6 and 8.
- Subgrade with a moisture content exceeding 18% and an organic content exceeding 8% may be a candidate for remedial action.
- See attached IDOT IBV Based Remedial Action chart from the IDOT Subgrade Stability Manual for reference.

Based on the above criteria, the following boring locations have been highlighted for potential subgrade stabilization, **only if the subbase soils are exposed**:

Table 7: Subgrade Stability Recommendations

CORE NUMBER	STREET NAME	IBV	ESTIMATED UNDERCUT THICKNESS	GEOTECHNICAL CONSIDERATIONS
C-01	Cortesi Avenue	4	6 - 12	N/A
C-02	Cortesi Avenue	3	6 – 12	N/A
C-03	Myrtle Avenue	4	6 - 12	N/A
C-04	Myrtle Avenue	3	6 – 12	N/A
C-05	Central Boulevard	4	6 - 12	N/A
C-06	Central Boulevard	3	6 – 12	Organic soils
C-07	Central Boulevard	4	6 – 12	Organic soils



CORE NUMBER	STREET NAME	IBV	ESTIMATED UNDERCUT THICKNESS	GEOTECHNICAL CONSIDERATIONS
C-08	Central Boulevard	3	6 – 12	Organic soils
C-09	Crescent Drive	5	18 – 24	Expansive soils
C-10	Crescent Drive	4	6 – 12	N/A
C-11	Myrtle Avenue	5	6 – 12	Organic soils
C-12	Myrtle Avenue	5	6 – 12	N/A
C-13	Myrtle Avenue	4	18 – 24	Expansive soils
C-14	Myrtle Avenue	3	12 – 18	N/A
C-15	Astor Court	4	18 – 24	Expansive soils
C-16	Astor Court	3	18 – 24	Expansive soils
C-17	Astor Court	7	0 – 6	Organic soils
C-18	Astor Court	4	6 - 12	N/A

Unstable soil should be treated in accordance with Article 301.04 of the standard specifications and undercut guidelines in the IDOT Subgrade Stability Manual.

If unsuitable soils are removed and the area is still wet or unstable, the underlying soils may be stabilized by “walking-in” consecutive layers of approximately 6 inches of 3-inch crushed stone placed on the subgrade until the voids of the 3-inch stone are filled with the soft soil. Construction grades may then be established using CA-6 stone, or the native soils following moisture conditioning. A layer of geotextile should be placed between the 3-inch stone / clay mixture and an open-graded stone, if applicable.



IBV Based Remedial Action Chart – IDOT

Reference IDOT Subgrade Stability Manual 2005

IBV BASED REMEDIAL ACTION

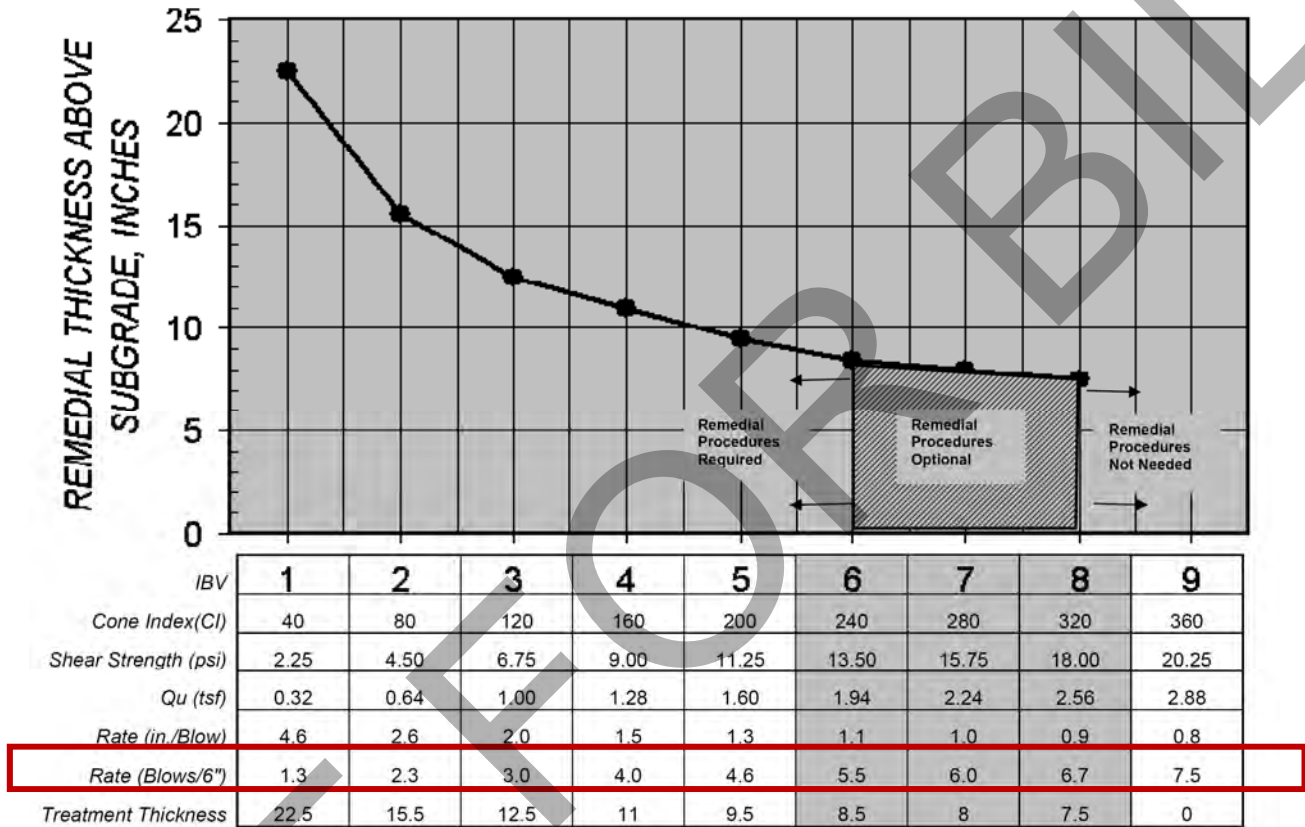

Figure A-2. Thickness design as a function of IBV, CI, Shear Strength, and Q_u for subgrade treatment (granular backfill or modified soil).



Roadway Drainage and Maintenance

Fine-grained soils can be sensitive to remodeling in the presence of water. In the areas of surficial clays, the surface should be maintained in a graded condition to prevent standing water on the subgrade. Appropriate measures may include, but are not limited to:

1. Shaping/pitching the sub-grade to drain toward side drainage ditch along the roadway.
2. Providing proper filtration for runoff waters. Proper drainage of the roadway is mandated by Article 202.05 of the IDOT Standard Specifications.
3. Rubino recommends placing CA-6 as the fill at the interface of clay and the new roadway. If open-graded stone is used, a geotextile should be placed between the fine-grained soil and the stone.
4. Rubino recommends pavements be sloped to provide rapid surface drainage. Water allowed to pond on or adjacent to the pavement could saturate the subgrade and cause premature deterioration of pavements, and removal and replacement may be required.
5. Consideration should be given to the use of an interceptor drain to collect and remove water collecting in the granular base. The interceptor drains could be incorporated with the storm drains of other utilities located in the pavement areas.
6. Periodic maintenance of the pavement should be anticipated. This should include sealing of cracks and joints and by maintaining proper surface drainage to avoid ponding of water on or near the pavement area.

CLOSING

The recommendations submitted are based on the available subsurface information obtained by Rubino Engineering, Inc. and design details furnished by RJN Group for the proposed project. If there are any revisions to the plans for this project or if deviations from the subsurface conditions noted in this report are encountered during construction, Rubino should be notified immediately to determine if changes in the foundation recommendations are required. If Rubino is not retained to perform these functions, we will not be responsible for the impact of those conditions on the project.

The scope of services did not include an environmental assessment to determine the presence or absence of wetlands, or hazardous or toxic materials in the soil, bedrock, surface water, groundwater or air, on, or below or around this site. Any statements in this report and/or on the boring logs regarding odors, colors, and/or unusual or suspicious items or conditions are strictly for informational purposes.

After the plans and specifications are more complete, the geotechnical engineer should be retained and provided the opportunity to review the final design plans and specifications to check that our engineering recommendations have been properly incorporated into the design documents. At this time, it may be necessary to submit supplementary recommendations. This



report has been prepared for the exclusive use of RJN Group and their consultants for the specific application to the proposed Sewer Separation and Road Reconstruction in Villa Park, Illinois.

NOT FOR BID



APPENDIX A - DRILLING, FIELD, AND LABORATORY TEST PROCEDURES

Penetration Tests and Split-Barrel Sampling of Soils

During the sampling procedure, Standard Penetration Tests (SPT's) were performed at regular intervals to obtain the standard penetration (N-value) of the soil. The results of the standard penetration test are used to estimate the relative strength and compressibility of the soil profile components through empirical correlations to the soils' relative density and consistency. The split-barrel sampler obtains a soil sample for classification purposes and laboratory testing, as appropriate for the type of soil obtained.

Water Level Measurements

Water level observations were attempted during and upon completion of the drilling operation using a 100-foot tape measure. The depths of observed water levels in the boreholes are noted on the boring logs presented in the appendix of this report. In the borings where water is unable to be observed during the field activities, in relatively impervious soils, the accurate determination of the groundwater elevation may not be possible even after several days of observation. Seasonal variations, temperature and recent rainfall conditions may influence the levels of the groundwater table and volumes of water will depend on the permeability of the soils.

Water (Moisture) Content of Soil by Mass (Laboratory)

The water content is an important index property used in expressing the phase relationship of solids, water, and air in a given volume of material and can be used to correlate soil behavior with its index properties. In fine grained cohesive soils, the behavior of a given soil type often depends on its natural water content. The water content of a cohesive soil along with its liquid and plastic limits as determined by Atterberg Limit testing are used to express the soil's relative consistency or liquidity index.

Atterberg Limits (Laboratory)

Atterberg limit testing defines the liquid limit (LL) and plastic limit (PL) states of a given soil. These limits are used to determine the moisture content limits where the soil characteristics changes from behaving more like a fluid on the liquid limit end to where the soil behaves more like individual soil particles on the plastic limit end. The liquid limit is often used to determine if a soil is a low or high plasticity soil.

The plasticity index (PI) is difference between the liquid limit and the plastic limit. The plasticity index is used in conjunction with the liquid limit to determine if the material will behave like a silt or clay.

APPENDIX B - REPORT LIMITATIONS

Subsurface Conditions:

The subsurface description is of a generalized nature to highlight the major subsurface stratification features and material characteristics. The boring logs included in the appendix should be reviewed for specific information at individual boring locations. These records include soil descriptions, stratifications, penetration resistances, locations of the samples and laboratory test data as well as water level information. The stratifications shown on the boring logs represent the conditions only at the actual boring locations. Variations may occur, and should be expected between boring locations. The stratifications represent the approximate boundary between subsurface materials and the actual transition between layers may be gradual. The samples, which were not altered by laboratory testing, will be retained for up to 60 days from the date of this report and then will be discarded.

Geotechnical Risk:

The concept of risk is an important aspect of the geotechnical evaluation. The primary reason for this is that the analytical methods used to develop geotechnical recommendations do not comprise an exact science. The analytical tools that geotechnical engineers use are generally empirical and must be used in conjunction with engineering judgment and experience. Therefore, the solutions and recommendations presented in the geotechnical evaluation should not be considered risk-free, and more importantly, are not a guarantee that the interaction between the soils and the proposed structure will perform as planned. The engineering recommendations, presented in the preceding section, constitute Rubino's professional estimate of the necessary measures for the proposed structure to perform according to the proposed design based on the information generated and reference during this evaluation, and Rubino's experience in working with these conditions.

Warranty:

The geotechnical engineer warrants that the findings, recommendations, specifications, or professional advice contained herein have been made in accordance with generally accepted professional geotechnical engineering practices in the local area. No other warranties are implied or expressed.

Federal Excavation Regulations:

In Federal Register, Volume 54, No. 209 (October 1989), the United States Department of Labor, Occupational Safety and Health Administration (OSHA) amended its "Construction Standards for Excavations, 29 CFR, part 1926, Subpart P". This document was issued to better insure the safety of workmen entering trenches or excavations. This federal regulation mandates that all excavations, whether they be utility trenches, basement excavation or footing excavations, be constructed in accordance with the new OSHA guidelines. It is our understanding that these regulations are being strictly enforced and if they are not closely followed, the owner and the contractor could be liable for substantial penalties.

The contractor is solely responsible for designing and constructing stable, temporary excavations and should shore, slope, or bench the sides of the excavations as required to maintain stability of both the excavation sides and bottom. The contractor's "responsible person," as defined in 29 CFR Part 1926, should evaluate the soil exposed in the excavations as part of the contractor's safety procedures. In no case should slope height, slope inclination, or excavation depth, including utility trench excavation depth, exceed those specified in local, state, and federal safety regulations. Rubino is providing this information solely as a service to our client. Rubino is not assuming responsibility for construction site safety or the contractor's activities; such responsibility is not being implied and should not be inferred.

APPENDIX C - SOIL CLASSIFICATION GENERAL NOTES

DRILLING & SAMPLING SYMBOLS:

SS: Split Spoon - 1 3/8" I.D., 2" O.D., unless otherwise noted
 ST: Thin-Walled Tube - 3" O.D., Unless otherwise noted
 PM: Pressuremeter
 RB: Rock Bit
 DB: Diamond Bit - 4", N, B

PS: Piston Sample
 WS: Wash Sample
 HA: Hand Auger
 HS: Hollow Stem Auger
 BS: Bulk Sample

Standard "N" Penetration: Blows per foot of a 140 pound hammer falling 30 inches on a 2 inch O.D. split spoon sampler (SS), except where noted.

WATER LEVEL MEASUREMENT SYMBOLS:

Water levels indicated on the boring logs are the levels measured in the borings at the times indicated. In pervious soils, the indicated levels may reflect the location of groundwater. In low permeability soils, the accurate determination of ground water levels is not possible with only short term observations.

DESCRIPTIVE SOIL CLASSIFICATION:

Soil Classification is based on the Unified Soil Classification System as defined in ASTM D-2487 and D-2488. Coarse Grained Soils have more than 50% of their dry weight retained on a #200 sieve; they are described as: boulders, cobbles, gravel or sand. Fine Grained Soils have less than 50% of their dry weight retained on a #200 sieve; they are described as: clays, if they are plastic, and silts if they are slightly plastic or non-plastic. Major constituents may be added as modifiers and minor constituents may be added according to the relative proportions based on grain size. In addition to gradation, coarse grained soils are defined on the basis of their relative in-place density and fine grained soils on the basis of their consistency. Example: Lean clay with sand, trace gravel, stiff (CL); silty sand, trace gravel, medium dense (SM).

CONSISTENCY OF FINE-GRAINED SOILS:

Unconfined Compressive Strength, Qu (tsf)	N-Blows/ft.	Consistency
< 0.25	< 2	Very Soft
0.25 - 0.5	2 - 4	Soft
0.5 - 1	4 - 8	Medium Stiff
1 - 2	8 - 15	Stiff
2 - 4	15 - 30	Very Stiff
4 - 8	30 +	Hard

RELATIVE DENSITY OF COARSE-GRAINED SOILS

N-Blows/ft.	Relative Density
0 - 4	Very Loose
4 - 10	Loose
10 - 30	Medium Dense
30 - 50	Dense
50 +	Very Dense

RELATIVE PROPORTIONS OF SAND & GRAVEL

Descriptive Term	% of Dry Weight
Trace	< 15
With	15 - 29
Modifier	> 30

GRAIN SIZE TERMINOLOGY

Major Component	Size Range
Boulders	Over 12 in. (300mm)
Cobbles	12 in. To 3 in. (300mm to 75mm)
Gravel	3 in. To #4 sieve (75mm to 4.75mm)
Sand	#4 to #200 sieve (4.75mm to 0.75mm)

RELATIVE PROPORTIONS OF FINES

Descriptive Term	% of Dry Weight
Trace	< 5
With	5 - 12
Modifier	> 12

*Descriptive Terms apply to components also present in sample

APPENDIX D- SOIL CLASSIFICATION GENERAL NOTES

SOIL CLASSIFICATION CHART

NOTE: DUAL SYMBOLS ARE USED TO INDICATE BORDERLINE SOIL CLASSIFICATIONS

MAJOR DIVISIONS			SYMBOLS		TYPICAL DESCRIPTIONS	
			GRAPH	LETTER		
COARSE GRAINED SOILS	GRAVEL AND GRAVELLY SOILS	CLEAN GRAVELS (LITTLE OR NO FINES)		GW	WELL-GRADED GRAVELS, GRAVEL - SAND MIXTURES, LITTLE OR NO FINES	
		GRAVELS WITH FINES (APPRECIABLE AMOUNT OF FINES)		GP	POORLY-GRADED GRAVELS, GRAVEL - SAND MIXTURES, LITTLE OR NO FINES	
		GRAVELS WITH FINES (APPRECIABLE AMOUNT OF FINES)		GM	SILTY GRAVELS, GRAVEL - SAND - SILT MIXTURES	
	MORE THAN 50% OF COARSE FRACTION RETAINED ON NO. 4 SIEVE	SAND AND SANDY SOILS	CLEAN SANDS (LITTLE OR NO FINES)		SW	WELL-GRADED SANDS, GRAVELLY SANDS, LITTLE OR NO FINES
			SANDS WITH FINES (APPRECIABLE AMOUNT OF FINES)		SP	POORLY-GRADED SANDS, GRAVELLY SAND, LITTLE OR NO FINES
			SANDS WITH FINES (APPRECIABLE AMOUNT OF FINES)		SM	SILTY SANDS, SAND - SILT MIXTURES
FINE GRAINED SOILS	SILTS AND CLAYS	LIQUID LIMIT LESS THAN 50		ML	INORGANIC SILTS AND VERY FINE SANDS, ROCK FLOUR, SILTY OR CLAYEY FINE SANDS OR CLAYEY SILTS WITH SLIGHT PLASTICITY	
				CL	INORGANIC CLAYS OF LOW TO MEDIUM PLASTICITY, GRAVELLY CLAYS, SANDY CLAYS, SILTY CLAYS, LEAN CLAYS	
				OL	ORGANIC SILTS AND ORGANIC SILTY CLAYS OF LOW PLASTICITY	
	MORE THAN 50% OF MATERIAL IS SMALLER THAN NO. 200 SIEVE SIZE	SILTS AND CLAYS	LIQUID LIMIT GREATER THAN 50		MH	INORGANIC SILTS, MICACEOUS OR DIATOMACEOUS FINE SAND OR SILTY SOILS
					CH	INORGANIC CLAYS OF HIGH PLASTICITY
					OH	ORGANIC CLAYS OF MEDIUM TO HIGH PLASTICITY, ORGANIC SILTS
HIGHLY ORGANIC SOILS				PT	PEAT, HUMUS, SWAMP SOILS WITH HIGH ORGANIC CONTENTS	

NOT FOR BID

APPENDIX E – SITE VICINITY MAP, BORING LOCATION PLAN & CORING LOCATION PLAN



ENGINEERING INC.

665 Tollgate Rd. Unit H
Elgin, Illinois 60123

Project Name: Proposed Sewer Separation and Road Reconstruction
Project Location: Various Streets

Client: Villa Park, Illinois

Rubino Project # : RJN Group, Inc. G16.124

**Site
Vicinity
Map**

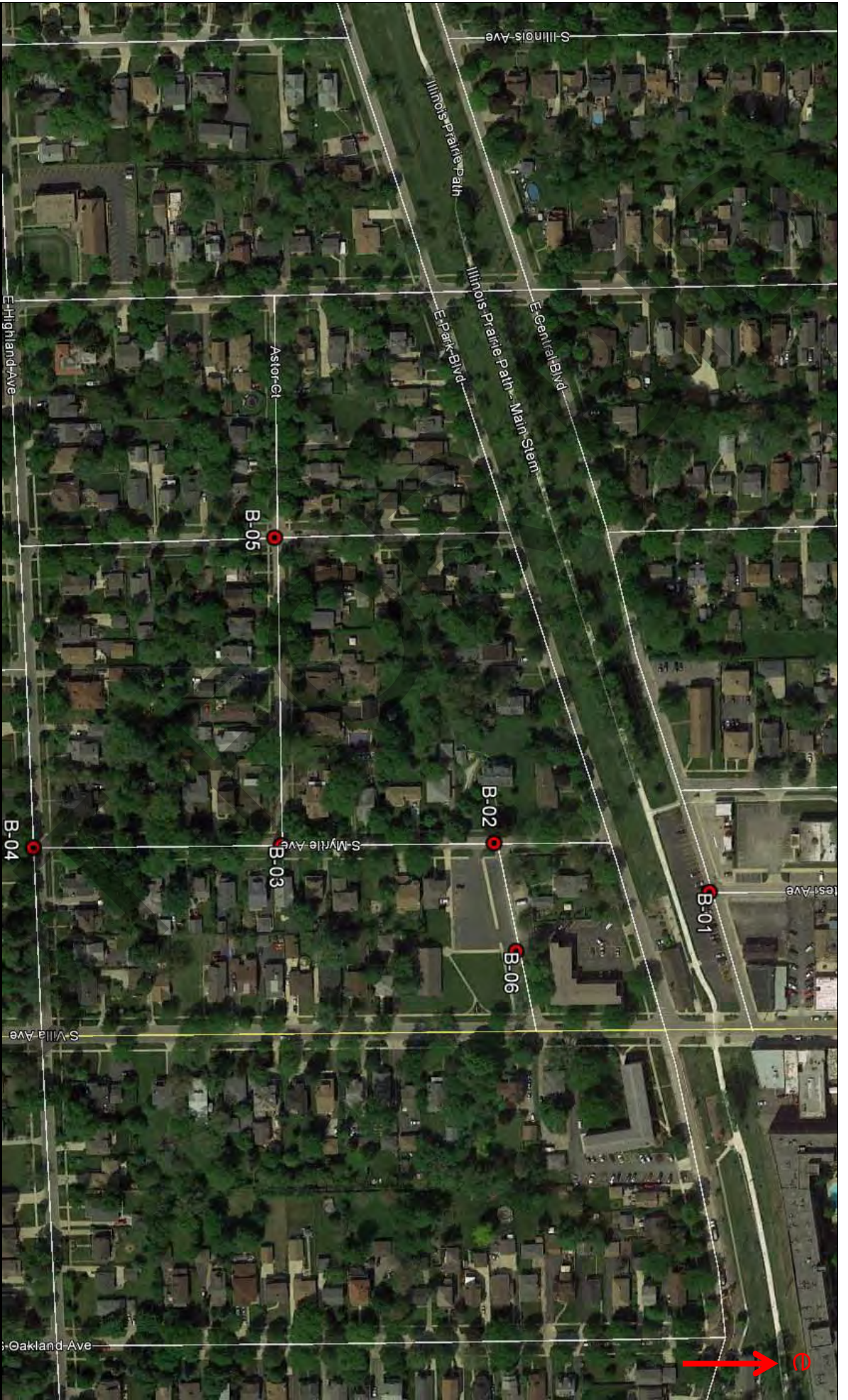

665 Tollgate Rd. Unit H
 Elgin, Illinois 60123

Project Name: Proposed Sewer Separation and Road Reconstruction
Project Location: Various Streets

Client: Villa Park, Illinois

Rubino Project # : RJN Group, Inc. G16.124

**Boring
 Location
 Plan**

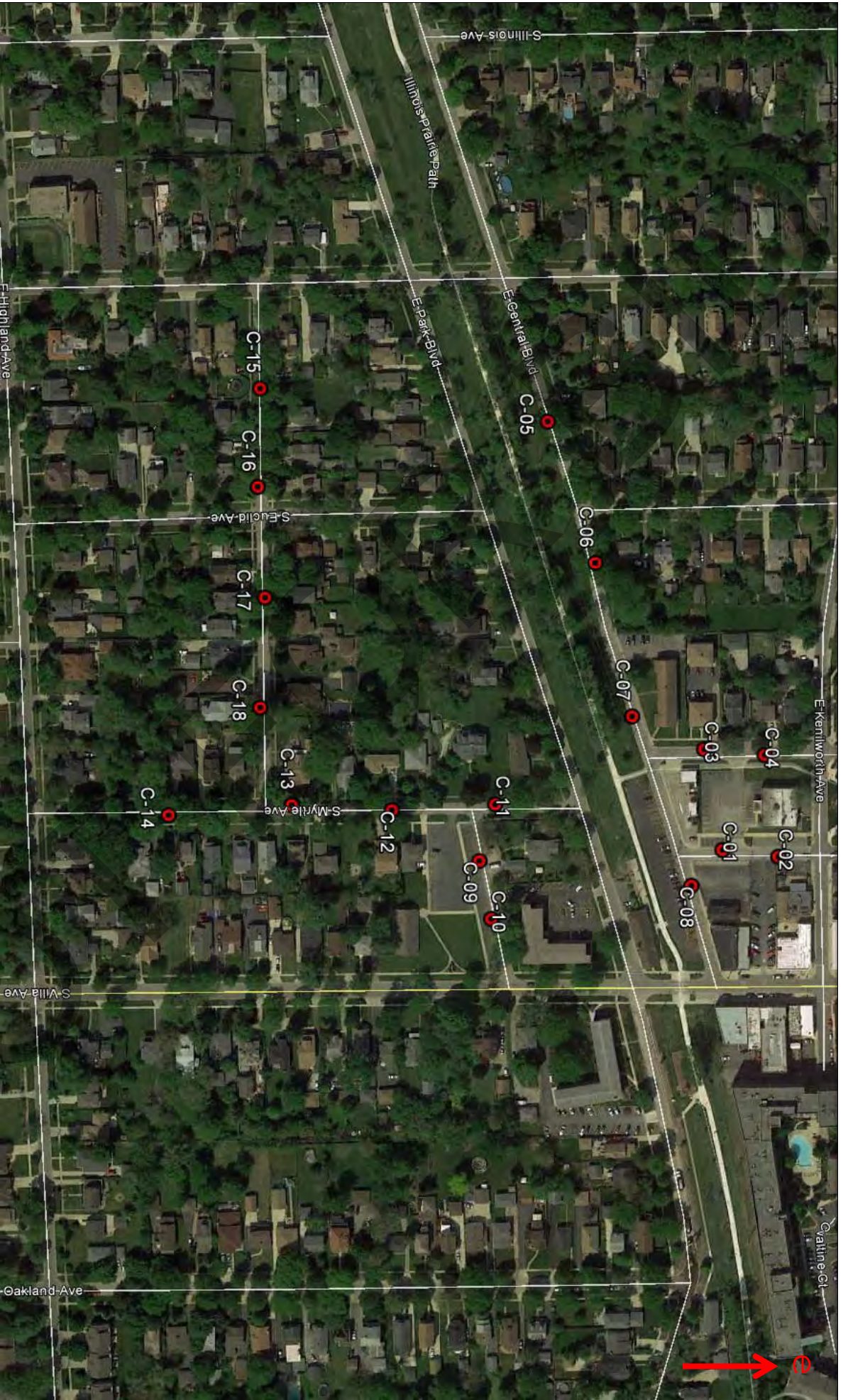

665 Tollgate Rd. Unit H
Elgin, Illinois 60123

Project Name: Proposed Sewer Separation and Road Reconstruction
Project Location: Various Streets

Client: RJN Group, Inc.
Rubino Project # : G16.124

**Coring
Location
Plan**

APPENDIX F – BORING LOGS

NOT FOR BID

Rubino Job No.: G16.124	Drilling Method: 3 1/4" Hollow Stem Auger	WATER LEVELS
Project: Proposed Sewer Separation and Road Reconstruction	Sampling Method: Split Spoon	▽ While Drilling N/A
Location: Various Streets	Hammer Type: Automatic	▼ Upon Completion N/A
City, State: Villa Park, Illinois	Boring Location: Central Boulevard and Cortesi Avenue	▽ Delay N/A
Client: RJN Group	Villa Park, Illinois	

Elevation (feet)	Depth (feet)	Graphic Log	Sample Type	Sample No.	Recovery (inches)	Station: N/A Offset: N/A	MATERIAL DESCRIPTION	USCS Classification	SPT Blows per 6-inch (SS)	Moisture, %	STRENGTH, tsf	Additional Remarks
0		Approximately 3 inches of ASPHALT Approximately 8 inches of CONCRETE										
		Brown and gray silty CLAY, trace sand and gravel; Medium stiff to stiff		1	14				2,3,3 N=6	17	⊗	Qp=1.5 tsf
				2	18			CL	3,4,5 N=9	19	⊗	>> Qp=4.5 tsf
	5			3	18				4,6,10 N=16	18	⊗	>> Qp=4.5 tsf
		Gray silty CLAY, trace sand and gravel; Stiff		4	16				2,5,6 N=11	17	⊗	>> Qp=4.5 tsf
	10			5	18			CL	3,5,6 N=11	14	⊗	* Qp=3.5 tsf
	15	End of boring at approximately 15 feet. No free groundwater encountered during drilling operation.										

Completion Depth: 15.0 ft	Sample Types:	Latitude: 41°53'9.19"N
Date Boring Started: 9/23/16	Auger Cutting	Longitude: 87°58'12.21"W
Date Boring Completed: 9/23/16	Split-Spoon	Drill Rig: Geoprobe 7822DT
Logged By: J.W.	Rock Core	Remarks: Sewer Separation
Drilling Contractor: Rubino Engineering, Inc.	Shelby Tube	
	Hand Auger	
	Texas Cone	

The stratification lines represent approximate boundaries. The transition may be gradual.

Rubino Job No.: G16.124	Drilling Method: 3 1/4" Hollow Stem Auger	WATER LEVELS
Project: Proposed Sewer Separation and Road Reconstruction	Sampling Method: Split Spoon	▽ While Drilling N/A
Location: Various Streets	Hammer Type: Automatic	▼ Upon Completion N/A
City, State: Villa Park, Illinois	Boring Location: Crescent Drive and Myrtle Avenue	▽ Delay N/A
Client: RJN Group	Villa Park, Illinois	

Elevation (feet)	Depth (feet)	Graphic Log	Sample Type	Sample No.	Recovery (inches)	Station: N/A Offset: N/A	MATERIAL DESCRIPTION	USCS Classification	SPT Blows per 6-inch (SS)	Moisture, %	STRENGTH, tsf	Additional Remarks
0		ASPHALT					Approximately 3 inches of ASPHALT					
		CONCRETE					Approximately 8 inches of CONCRETE					
		CLAY		1	14		Brown and gray silty CLAY, trace sand and gravel; Medium stiff to stiff	CL	2,2,4 N=6	25	2.0	Qp=2.0 tsf 4% Organic Content
		CLAY		2	16			CL	2,2,3 N=5	19	2.0	Qp=2.0 tsf
5		CLAY		3	18			CL	3,4,5 N=9	18	4.0	Qp=4.0 tsf
		CLAY		4	18			CL	3,6,6 N=12	21	4.5	Qp=4.5 tsf
10		CLAY		5	18		Gray silty CLAY, trace sand and gravel; Medium stiff to stiff	CL	3,3,5 N=8	18	2.5	Qp=2.5 tsf
15							End of boring at approximately 15 feet. No free groundwater encountered during drilling operation.					

Completion Depth: 15.0 ft	Sample Types:	Latitude: 41°53'5.41"N
Date Boring Started: 9/23/16	Auger Cutting	Longitude: 87°58'13.39"W
Date Boring Completed: 9/23/16	Split-Spoon	Drill Rig: Geoprobe 7822DT
Logged By: J.W.	Rock Core	Remarks: Sewer Separation
Drilling Contractor: Rubino Engineering, Inc.	Shelby Tube	
	Hand Auger	
	Texas Cone	

The stratification lines represent approximate boundaries. The transition may be gradual.

Rubino Job No.: G16.124	Drilling Method: 3 1/4" Hollow Stem Auger	WATER LEVELS
Project: Proposed Sewer Separation and Road Reconstruction	Sampling Method: Split Spoon	▽ While Drilling N/A
Location: Various Streets	Hammer Type: Automatic	▼ Upon Completion N/A
City, State: Villa Park, Illinois	Boring Location: Astor Court and Myrtle Avenue	▼ Delay N/A
Client: RJN Group	Villa Park, Illinois	

Elevation (feet)	Depth (feet)	Graphic Log	Sample Type	Sample No.	Recovery (inches)	Station: N/A Offset: N/A	MATERIAL DESCRIPTION	USCS Classification	SPT Blows per 6-inch (SS)	Moisture, %	STRENGTH, tsf	Additional Remarks
0		Approximately 2 inches of ASPHALT Approximately 8 inches of CONCRETE										
		Brown and gray silty CLAY, trace sand and gravel; Medium stiff to stiff		1	18				2,3,3 N=6	15	⊗	Qp=3.0 tsf 5% Organic Content
				2	18				2,3,3 N=6	16	⊗	Qp=3.0 tsf
	5			3	18			CL	3,5,6 N=11	18	⊗	>> Qp=4.5 tsf
				4	18				4,5,6 N=11	20	⊗	>> Qp=4.5 tsf
	10			5	18		Gray silty CLAY, trace sand and gravel; Medium stiff to stiff	CL	3,4,4 N=8	25	⊗	Qp=3.0 tsf
	15						End of boring at approximately 15 feet. No free groundwater encountered during drilling operation.					

Completion Depth: 15.0 ft	Sample Types:	Latitude: 41°53'1.66"N
Date Boring Started: 9/23/16	Auger Cutting	Longitude: 87°58'13.34"W
Date Boring Completed: 9/23/16	Split-Spoon	Drill Rig: Geoprobe 7822DT
Logged By: J.W.	Rock Core	Remarks: Sewer Separation
Drilling Contractor: Rubino Engineering, Inc.	Shelby Tube	
	Hand Auger	
	Texas Cone	

The stratification lines represent approximate boundaries. The transition may be gradual.

Rubino Job No.: G16.124 Project: Proposed Sewer Separation and Road Reconstruction Location: Various Streets City, State: Villa Park, Illinois Client: RJN Group	Drilling Method: 3 1/4" Hollow Stem Auger Sampling Method: Split Spoon Hammer Type: Automatic Boring Location: Myrtle Avenue and Highland Avenue Villa Park, Illinois	WATER LEVELS ▽ While Drilling N/A ▽ Upon Completion N/A ▽ Delay N/A
--	---	---

Elevation (feet)	Depth (feet)	Graphic Log	Sample Type	Sample No.	Recovery (inches)	Station: N/A Offset: N/A	MATERIAL DESCRIPTION	USCS Classification	SPT Blows per 6-inch (SS)	Moisture, %	STRENGTH, tsf	Additional Remarks
0		Approximately 4 inches of ASPHALT Approximately 8 inches of CONCRETE										
		Brown and gray silty CLAY, trace sand and gravel; Medium stiff to stiff		1	8			CL	1,3,3 N=6	23	⊗	Qp=2.0 tsf
				2	18			CL	1,3,2 N=5	19	⊗	Qp=1.5 tsf
	5			3	18			CL	3,4,5 N=9	17	⊗	Qp=1.5 tsf
		Gray silty CLAY, trace sand and gravel; Medium stiff to very stiff		4	18			CL	6,8,10 N=18	15	⊗	>> Qp=4.5 tsf
	10			5	18			CL	3,3,5 N=8	15	⊗	Qp=2.0 tsf
	15						End of boring at approximately 15 feet. No free groundwater encountered during drilling operation.					

Completion Depth: 15.0 ft Date Boring Started: 9/23/16 Date Boring Completed: 9/23/16 Logged By: J.W. Drilling Contractor: Rubino Engineering, Inc.	Sample Types: Auger Cutting Split-Spoon Rock Core Shelby Tube Hand Auger Texas Cone	Latitude: 41°52'57.31"N Longitude: 87°58'13.29"W Drill Rig: Geoprobe 7822DT Remarks: Sewer Separation
---	---	--

The stratification lines represent approximate boundaries. The transition may be gradual.

Rubino Job No.: G16.124	Drilling Method: 3 1/4" Hollow Stem Auger	WATER LEVELS
Project: Proposed Sewer Separation and Road Reconstruction	Sampling Method: Split Spoon	▽ While Drilling N/A
Location: Various Streets	Hammer Type: Automatic	▼ Upon Completion N/A
City, State: Villa Park, Illinois	Boring Location: Astor Court and Euclid Avenue	▽ Delay N/A
Client: RJN Group	Villa Park, Illinois	

Elevation (feet)	Depth, (feet)	Graphic Log	Sample Type	Sample No.	Recovery (inches)	Station: N/A Offset: N/A	MATERIAL DESCRIPTION	USCS Classification	SPT Blows per 6-inch (SS)	Moisture, %	STRENGTH, tsf	Additional Remarks
0		Approximately 2 inches of ASPHALT Approximately 8 inches of CONCRETE										
		Brown and gray silty CLAY, trace sand and gravel; Medium stiff to very stiff		1	18			CL	2,3,4 N=7	18	Qp=2.0 tsf	
				2	18			CL	3,5,6 N=11	18	>>Qp=4.5 tsf	
	5			3	18			CL	5,6,10 N=16	17	>>Qp=4.5 tsf	
		Gray silty CLAY, trace sand and gravel; Medium stiff to stiff		4	18			CL	4,6,7 N=13	18	>>Qp=4.5 tsf	
	10			5	18			CL	3,3,5 N=8	15	Qp=3.0 tsf	
	15	End of boring at approximately 15 feet. No free groundwater encountered during drilling operation.										

Completion Depth: 15.0 ft	Sample Types:	Latitude: 41°53'1.55"N
Date Boring Started: 9/23/16	Auger Cutting	Longitude: 87°58'20.75"W
Date Boring Completed: 9/23/16	Split-Spoon	Drill Rig: Geoprobe 7822DT
Logged By: J.W.	Rock Core	Remarks: Sewer Separation
Drilling Contractor: Rubino Engineering, Inc.	Shelby Tube	
	Hand Auger	
	Texas Cone	

The stratification lines represent approximate boundaries. The transition may be gradual.

Rubino Job No.: G16.124 Project: Proposed Sewer Separation and Road Reconstruction Location: Various Streets City, State: Villa Park, Illinois Client: RJN Group	Drilling Method: 3 1/4" Hollow Stem Auger Sampling Method: Split Spoon Hammer Type: Automatic Boring Location: Crescent Drive Villa Park, Illinois	WATER LEVELS ▽ While Drilling N/A ▽ Upon Completion N/A ▽ Delay N/A
--	--	---

Elevation (feet)	Depth (feet)	Graphic Log	Sample Type	Sample No.	Recovery (inches)	Station: N/A Offset: N/A	MATERIAL DESCRIPTION	USCS Classification	SPT Blows per 6-inch (SS)	Moisture, %	STRENGTH, tsf	Additional Remarks
0	0	ASPHALT					Approximately 6 inches of ASPHALT					
		GRAVEL BASE					Approximately 6 inches of GRAVEL BASE					
		CLAY		1	12		Brown and gray silty CLAY with organics, trace sand and gravel; Stiff	CL	2,4,5 N=9	28	1.5	Qp=1.5 tsf 10% Organic Content
		CLAY		2	18		Brown and gray silty CLAY, trace sand and gravel; Medium stiff to stiff	CL	2,2,3 N=5	23	1.5	Qp=1.5 tsf
5		CLAY		3	18			CL	2,4,4 N=8	19	2.0	Qp=2.0 tsf
		CLAY		4	18		Gray silty CLAY, trace sand and gravel; Stiff to very stiff	CL	4,7,9 N=16	15	4.5	>> Qp=4.5 tsf
10		CLAY		5	18			CL	4,5,6 N=11	15	4.5	>> Qp=4.5 tsf
15							End of boring at approximately 15 feet. No free groundwater encountered during drilling operation.					

Completion Depth: 15.0 ft Date Boring Started: 9/23/16 Date Boring Completed: 9/23/16 Logged By: J.W. Drilling Contractor: Rubino Engineering, Inc.	Sample Types: Auger Cutting Split-Spoon Rock Core Shelby Tube Hand Auger Texas Cone	Latitude: 41°53'5.80"N Longitude: 87°58'10.78"W Drill Rig: Geoprobe 7822DT Remarks: Sewer Separation
---	--	---

The stratification lines represent approximate boundaries. The transition may be gradual.

Rubino Job No.: G16.124	Drilling Method: 3 1/4" Hollow Stem Auger	WATER LEVELS ▽ While Drilling N/A ▼ Upon Completion N/A ▽ Delay N/A
Project: Proposed Sewer Separation and Road Reconstruction	Sampling Method: Split Spoon	
Location: Various Streets	Hammer Type: Automatic	
City, State: Villa Park, Illinois	Boring Location: Central Boulevard and Cortesi Avenue	
Client: RJN Group	Villa Park, Illinois	

Elevation (feet)	Depth (feet)	Graphic Log	Sample Type	Sample No.	Recovery (inches)	MATERIAL DESCRIPTION	USCS Classification	DCP Blows per 6-inch	STANDARD PENETRATION TEST DATA		Additional Remarks	
									Moisture, %	STRENGTH, tsf		
0		Approximately 3 inches of ASPHALT Approximately 8 inches of CONCRETE										
		Brown and gray silty CLAY, trace sand and gravel; Medium stiff to stiff		1	14			2,3,3 N=6	17	⊗	⊗	Qp=1.5 tsf
				2	18		CL	3,4,5 N=9	19	⊗	⊗	>>Qp=4.5 tsf
5				3	18			4,6,10 N=16	18	⊗	⊗	>>Qp=4.5 tsf
		Gray silty CLAY, trace sand and gravel; Stiff		4	16			2,5,6 N=11	17	⊗	⊗	>>Qp=4.5 tsf
10				5	18		CL	3,5,6 N=11	14	⊗	⊗	* Qp=3.5 tsf
15		End of boring at approximately 15 feet. No free groundwater encountered during drilling operation.										

Completion Depth: 15.0 ft	Sample Types:	Latitude: 41°53'9.19"N
Date Boring Started: 9/23/16	Auger Cutting Split-Spoon Rock Core	Longitude: 87°58'12.21"W
Date Boring Completed: 9/23/16	Shelby Tube Hand Auger Texas Cone	Drill Rig: Geoprobe 7822DT
Logged By: J.W.		Remarks: Sewer Separation
Drilling Contractor: Rubino Engineering, Inc.		

The stratification lines represent approximate boundaries. The transition may be gradual.

Rubino Job No.: G16.124	Drilling Method: 3 1/4" Hollow Stem Auger	WATER LEVELS
Project: Proposed Sewer Separation and Road Reconstruction	Sampling Method: Split Spoon	▽ While Drilling N/A
Location: Various Streets	Hammer Type: Automatic	▼ Upon Completion N/A
City, State: Villa Park, Illinois	Boring Location: Crescent Drive and Myrtle Avenue	⏸ Delay N/A
Client: RJN Group	Villa Park, Illinois	

Elevation (feet)	Depth (feet)	Graphic Log	Sample Type	Sample No.	Recovery (inches)	Station: N/A Offset: N/A	MATERIAL DESCRIPTION	USCS Classification	DCP Blows per 6-inch	Moisture, %	STRENGTH, tsf	Additional Remarks
0		Approximately 3 inches of ASPHALT Approximately 8 inches of CONCRETE										
		Brown and gray silty CLAY, trace sand and gravel; Medium stiff to stiff		1	14			CL	2,2,4 N=6	25	⊙ * * *	Qp=2.0 tsf 4% Organic Content
				2	16				2,2,3 N=5	19	⊙ * * *	Qp=2.0 tsf
5				3	18			CL	3,4,5 N=9	18	⊙ * * *	Qp=4.0 tsf
				4	18				3,6,6 N=12	21	⊙ * * *	>> Qp=4.5 tsf
10				5	18		Gray silty CLAY, trace sand and gravel; Medium stiff to stiff	CL	3,3,5 N=8	18	⊙ * * *	Qp=2.5 tsf
15		End of boring at approximately 15 feet. No free groundwater encountered during drilling operation.										

Completion Depth: 15.0 ft	Sample Types:	Latitude: 41°53'5.41"N
Date Boring Started: 9/23/16	Auger Cutting	Longitude: 87°58'13.39"W
Date Boring Completed: 9/23/16	Split-Spoon	Drill Rig: Geoprobe 7822DT
Logged By: J.W.	Rock Core	Remarks: Sewer Separation
Drilling Contractor: Rubino Engineering, Inc.	Shelby Tube	
	Hand Auger	
	Texas Cone	

The stratification lines represent approximate boundaries. The transition may be gradual.

Rubino Job No.: G16.124	Drilling Method: 3 1/4" Hollow Stem Auger	WATER LEVELS
Project: Proposed Sewer Separation and Road Reconstruction	Sampling Method: Split Spoon	▽ While Drilling N/A
Location: Various Streets	Hammer Type: Automatic	▼ Upon Completion N/A
City, State: Villa Park, Illinois	Boring Location: Astor Court and Myrtle Avenue	⚠ Delay N/A
Client: RJN Group		

Elevation (feet)	Depth (feet)	Graphic Log	Sample Type	Sample No.	Recovery (inches)	MATERIAL DESCRIPTION	USCS Classification	DCP Blows per 6-inch	STANDARD PENETRATION TEST DATA		Additional Remarks
									Moisture, %	STRENGTH, tsf	
0						Station: N/A Offset: N/A			Moisture: 0, 25, 50	Qu, Qp	
						Approximately 2 inches of ASPHALT Approximately 8 inches of CONCRETE					
				1	18	Brown and gray silty CLAY, trace sand and gravel; Medium stiff to stiff		2,3,3 N=6	15	⊗	* Qp=3.0 tsf 5% Organic Content
				2	18			2,3,3 N=6	16	⊗	* Qp=3.0 tsf
	5			3	18		CL	3,5,6 N=11	18	⊗	>>* Qp=4.5 tsf
				4	18			4,5,6 N=11	20	⊗	>>* Qp=4.5 tsf
	10			5	18	Gray silty CLAY, trace sand and gravel; Medium stiff to stiff		3,4,4 N=8	25	⊗	* Qp=3.0 tsf
	15					End of boring at approximately 15 feet. No free groundwater encountered during drilling operation.					

Completion Depth: 15.0 ft	Sample Types:	Latitude: 41°53'1.66"N
Date Boring Started: 9/23/16	Auger Cutting	Longitude: 87°58'13.34"W
Date Boring Completed: 9/23/16	Split-Spoon	Drill Rig: Geoprobe 7822DT
Logged By: J.W.	Rock Core	Remarks: Sewer Separation
Drilling Contractor: Rubino Engineering, Inc.	Shelby Tube	
	Hand Auger	
	Texas Cone	

The stratification lines represent approximate boundaries. The transition may be gradual.

Rubino Job No.: G16.124	Drilling Method: 3 1/4" Hollow Stem Auger	WATER LEVELS
Project: Proposed Sewer Separation and Road Reconstruction	Sampling Method: Split Spoon	▽ While Drilling N/A
Location: Various Streets	Hammer Type: Automatic	▼ Upon Completion N/A
City, State: Villa Park, Illinois	Boring Location: Myrtle Avenue and Highland Avenue	▽ Delay N/A
Client: RJN Group	Villa Park, Illinois	

Elevation (feet)	Depth (feet)	Graphic Log	Sample Type	Sample No.	Recovery (inches)	MATERIAL DESCRIPTION	USCS Classification	DCP Blows per 6-inch	STANDARD PENETRATION TEST DATA		Additional Remarks	
									Moisture, %	STRENGTH, tsf		
0		Approximately 4 inches of ASPHALT Approximately 8 inches of CONCRETE										
		Brown and gray silty CLAY, trace sand and gravel; Medium stiff to stiff		1	8		CL	1,3,3 N=6	23	⊗	⊗	Qp=2.0 tsf
				2	18		CL	1,3,2 N=5	19	⊗	⊗	Qp=1.5 tsf
				3	18			3,4,5 N=9	17	⊗	⊗	Qp=1.5 tsf
		Gray silty CLAY, trace sand and gravel; Medium stiff to very stiff		4	18		CL	6,8,10 N=18	15	⊗	⊗	>>Qp=4.5 tsf
				5	18			3,3,5 N=8	15	⊗	⊗	Qp=2.0 tsf
		End of boring at approximately 15 feet. No free groundwater encountered during drilling operation.										

Completion Depth: 15.0 ft	Sample Types:	Latitude: 41°52'57.31"N
Date Boring Started: 9/23/16	Auger Cutting	Longitude: 87°58'13.29"W
Date Boring Completed: 9/23/16	Split-Spoon	Drill Rig: Geoprobe 7822DT
Logged By: J.W.	Rock Core	Remarks: Sewer Separation
Drilling Contractor: Rubino Engineering, Inc.	Shelby Tube	
	Hand Auger	
	Texas Cone	

The stratification lines represent approximate boundaries. The transition may be gradual.

Rubino Job No.: G16.124
 Project: Proposed Sewer Separation and Road Reconstruction
 Location: Various Streets
 City, State: Villa Park, Illinois
 Client: RJN Group

Drilling Method: 3 1/4" Hollow Stem Auger
 Sampling Method: Split Spoon
 Hammer Type: Automatic
 Boring Location: Astor Court and Euclid Avenue
 Villa Park, Illinois

WATER LEVELS	
▽ While Drilling	N/A
▼ Upon Completion	N/A
▽ Delay	N/A

Elevation (feet)	Depth (feet)	Graphic Log	Sample Type	Sample No.	Recovery (inches)	MATERIAL DESCRIPTION	USCS Classification	DCP Blows per 6-inch	STANDARD PENETRATION TEST DATA		Additional Remarks
									Moisture, %	STRENGTH, tsf	
0						Station: N/A Offset: N/A					
						Approximately 2 inches of ASPHALT Approximately 8 inches of CONCRETE					
				1	18	Brown and gray silty CLAY, trace sand and gravel; Medium stiff to very stiff		2,3,4 N=7	18	⊗	Qp=2.0 tsf
				2	18		CL	3,5,6 N=11	18	⊗	>>Qp=4.5 tsf
	5			3	18			5,6,10 N=16	17	⊗	>>Qp=4.5 tsf
				4	18	Gray silty CLAY, trace sand and gravel; Medium stiff to stiff		4,6,7 N=13	18	⊗	>>Qp=4.5 tsf
	10			5	18		CL	3,3,5 N=8	15	⊗	Qp=3.0 tsf
	15					End of boring at approximately 15 feet. No free groundwater encountered during drilling operation.					

Completion Depth: 15.0 ft
 Date Boring Started: 9/23/16
 Date Boring Completed: 9/23/16
 Logged By: J.W.
 Drilling Contractor: Rubino Engineering, Inc.

Sample Types:

Auger Cutting	Shelby Tube
Split-Spoon	Hand Auger
Rock Core	Texas Cone

Latitude: 41°53'1.55"N
 Longitude: 87°58'20.75"W
 Drill Rig: Geoprobe 7822DT
 Remarks: Sewer Separation

The stratification lines represent approximate boundaries. The transition may be gradual.

Rubino Job No.: G16.124
 Project: Proposed Sewer Separation and Road Reconstruction
 Location: Various Streets
 City, State: Villa Park, Illinois
 Client: RJN Group

Drilling Method: 3 1/4" Hollow Stem Auger
 Sampling Method: Split Spoon
 Hammer Type: Automatic
 Boring Location: Crescent Drive
 Villa Park, Illinois

WATER LEVELS	
▽ While Drilling	N/A
▼ Upon Completion	N/A
⚠ Delay	N/A

Elevation (feet)	Depth, (feet)	Graphic Log	Sample Type	Sample No.	Recovery (inches)	MATERIAL DESCRIPTION	USCS Classification	DCP Blows per 6-inch	STANDARD PENETRATION TEST DATA		Additional Remarks
									Moisture, %	STRENGTH, tsf	
0		Approximately 6 inches of ASPHALT									
		Approximately 6 inches of GRAVEL BASE									
		Brown and gray silty CLAY with organics, trace sand and gravel; Stiff		1	12		CL	2,4,5 N=9	28	⊙ * X	Qp=1.5 tsf 10% Organic Content
		Brown and gray silty CLAY, trace sand and gravel; Medium stiff to stiff		2	18		CL	2,2,3 N=5	23	⊙ * X	Qp=1.5 tsf
5				3	18		CL	2,4,4 N=8	19	⊙ X *	Qp=2.0 tsf
		Gray silty CLAY, trace sand and gravel; Stiff to very stiff		4	18		CL	4,7,9 N=16	15	⊙ X	>>*Qp=4.5 tsf
10				5	18		CL	4,5,6 N=11	15	⊙ X	>>*Qp=4.5 tsf
15		End of boring at approximately 15 feet. No free groundwater encountered during drilling operation.									

Completion Depth: 15.0 ft
 Date Boring Started: 9/23/16
 Date Boring Completed: 9/23/16
 Logged By: J.W.
 Drilling Contractor: Rubino Engineering, Inc.

Sample Types:

Auger Cutting	Shelby Tube
Split-Spoon	Hand Auger
Rock Core	Texas Cone

Latitude: 41°53'5.80"N
 Longitude: 87°58'10.78"W
 Drill Rig: Geoprobe 7822DT
 Remarks: Sewer Separation

The stratification lines represent approximate boundaries. The transition may be gradual.

Rubino Job No.: G16.124	Drilling Method: Humboldt DCP + Hand Auger	WATER LEVELS
Project: Proposed Sewer Separation and Road Reconstruction	Sampling Method: Grab Sample	▽ While Drilling N/A
Location: Various Streets	Hammer Type: Humboldt DCP	▼ Upon Completion N/A
City, State: Villa Park, Illinois	Boring Location: Cortesi Avenue	▼ Delay N/A
Client: RJN Group	Villa Park, Illinois	

Elevation (feet)	Depth (feet)	Graphic Log	Sample Type	Sample No.	Recovery (inches)	Station: N/A Offset: N/A	MATERIAL DESCRIPTION	USCS Classification	DCP Blows per 6-inch	Moisture, %	STRENGTH, tsf	Additional Remarks
0		Approximately 2 inches of ASPHALT										
		Approximately 6 inches of CONCRETE										
		Brown and gray silty CLAY, trace sand and gravel		1	12				3,3			
				2	12			CL	5,4			
				3	12				6,9	19		LL = 35 PL = 18 4% Organic Content
				4	12				11,14			
5				5	6		End of hand auger at approximately 5 feet. No free groundwater encountered during drilling operation.		14			

Completion Depth: 5.0 ft	Sample Types:	Latitude: 41°53'10.05"N
Date Boring Started: 9/19/16	Auger Cutting	Longitude: 87°58'12.35"W
Date Boring Completed: 9/19/16	Split-Spoon	Drill Rig: Milwaukee Dymodrill Coring Machine
Logged By: T.R.	Rock Core	Remarks: Road Reconstruction
Drilling Contractor: Rubino Engineering, Inc.	Shelby Tube	
	Hand Auger	
	Texas Cone	

The stratification lines represent approximate boundaries. The transition may be gradual.

Rubino Job No.: G16.124	Drilling Method: Humboldt DCP + Hand Auger	WATER LEVELS	
Project: Proposed Sewer Separation and Road Reconstruction	Sampling Method: Grab Sample	▽ While Drilling	N/A
Location: Various Streets	Hammer Type: Humboldt DCP	▼ Upon Completion	N/A
City, State: Villa Park, Illinois	Boring Location: Cortesi Avenue	▼ Delay	N/A
Client: RJN Group	Villa Park, Illinois		

Elevation (feet)	Depth (feet)	Graphic Log	Sample Type	Sample No.	Recovery (inches)	Station: N/A Offset: N/A	MATERIAL DESCRIPTION	USCS Classification	DCP Blows per 6-inch	Moisture, %	STRENGTH, tsf	Additional Remarks
0		Approximately 2 ¼ inches of ASPHALT										
		Approximately 6 ¾ inches of CONCRETE										
		Brown and gray silty CLAY, trace sand and gravel		1	12				2.4			
				2	12			CL	3.5			
				3	12				6.8	21	Moisture: 21	PL = 34 LL = 18 6% Organic Content
				4	12				12,13			
5				5	6		End of hand auger at approximately 5 feet. No free groundwater encountered during drilling operation.		13			

Completion Depth: 5.0 ft	Sample Types:	Latitude: 41°53'11.08"N
Date Boring Started: 9/19/16	Auger Cutting	Longitude: 87°58'12.18"W
Date Boring Completed: 9/19/16	Split-Spoon	Drill Rig: Milwaukee Dymodrill Coring Machine
Logged By: T.R.	Rock Core	Remarks: Road Reconstruction
Drilling Contractor: Rubino Engineering, Inc.	Shelby Tube	
	Hand Auger	
	Texas Cone	

The stratification lines represent approximate boundaries. The transition may be gradual.

Rubino Job No.: G16.124	Drilling Method: Humboldt DCP + Hand Auger	WATER LEVELS	
Project: Proposed Sewer Separation and Road Reconstruction	Sampling Method: Grab Sample	▽ While Drilling	N/A
Location: Various Streets	Hammer Type: Humboldt DCP	▼ Upon Completion	N/A
City, State: Villa Park, Illinois	Boring Location: Myrtle Avenue	▼ Delay	N/A
Client: RJN Group	Villa Park, Illinois		

Elevation (feet)	Depth (feet)	Graphic Log	Sample Type	Sample No.	Recovery (inches)	Station: N/A Offset: N/A	MATERIAL DESCRIPTION	USCS Classification	DCP Blows per 6-inch	Moisture, %	STRENGTH, tsf	Additional Remarks
0		Approximately 1 1/2 inches of ASPHALT										
		Approximately 7 1/2 inches of CONCRETE										
		Brown and gray silty CLAY, trace sand and gravel		1	12				3,3			
				2	12			CL	5,4			
				3	12				6,7	17	□ — □	LL = 34 PL = 17 8% Organic Content
				4	12				14,12			
5				5	6		End of hand auger at approximately 5 feet. No free groundwater encountered during drilling operation.		12			

Completion Depth: 5.0 ft	Sample Types:	Latitude: 41°53'9.72"N
Date Boring Started: 9/20/16	Auger Cutting	Longitude: 87°58'14.88"W
Date Boring Completed: 9/20/16	Split-Spoon	Drill Rig: Milwaukee Dymodrill Coring Machine
Logged By: T.R.	Rock Core	Remarks: Road Reconstruction
Drilling Contractor: Rubino Engineering, Inc.	Shelby Tube	
	Hand Auger	
	Texas Cone	

The stratification lines represent approximate boundaries. The transition may be gradual.

Rubino Job No.: G16.124	Drilling Method: Humboldt DCP + Hand Auger	WATER LEVELS	
Project: Proposed Sewer Separation and Road Reconstruction	Sampling Method: Grab Sample	▽ While Drilling	N/A
Location: Various Streets	Hammer Type: Humboldt DCP	▼ Upon Completion	N/A
City, State: Villa Park, Illinois	Boring Location: Myrtle Avenue	▼ Delay	N/A
Client: RJN Group	Villa Park, Illinois		

Elevation (feet)	Depth, (feet)	Graphic Log	Sample Type	Sample No.	Recovery (inches)	Station: N/A Offset: N/A	MATERIAL DESCRIPTION	USCS Classification	DCP Blows per 6-inch	Moisture, %	STRENGTH, tsf	Additional Remarks
0		Approximately 2 1/2 inches of ASPHALT Approximately 7 inches of CONCRETE										
		Brown and gray silty CLAY, trace sand and gravel		1	12				3,4			
				2	12			CL	3,3			
				3	12				3,3	17	□ — □	LL = 34 PL = 17 8% Organic Content
				4	12				12,12			
5				5	6		End of hand auger at approximately 5 feet. No free groundwater encountered during drilling operation.		12			

Completion Depth: 5.0 ft	Sample Types:	Latitude: 41°53'10.83"N
Date Boring Started: 9/20/16	Auger Cutting	Longitude: 87°58'14.74"W
Date Boring Completed: 9/20/16	Split-Spoon	Drill Rig: Milwaukee Dymodrill Coring Machine
Logged By: T.R.	Rock Core	Remarks: Road Reconstruction
Drilling Contractor: Rubino Engineering, Inc.	Shelby Tube	
	Hand Auger	
	Texas Cone	

The stratification lines represent approximate boundaries. The transition may be gradual.

Rubino Job No.: G16.124	Drilling Method: Humboldt DCP + Hand Auger	WATER LEVELS	
Project: Proposed Sewer Separation and Road Reconstruction	Sampling Method: Grab Sample	▽ While Drilling	N/A
Location: Various Streets	Hammer Type: Humboldt DCP	▼ Upon Completion	N/A
City, State: Villa Park, Illinois	Boring Location: Central Boulevard	▼ Delay	N/A
Client: RJN Group	Boring Location: Villa Park, Illinois		

Elevation (feet)	Depth (feet)	Graphic Log	Sample Type	Sample No.	Recovery (inches)	Station: N/A Offset: N/A	MATERIAL DESCRIPTION	USCS Classification	DCP Blows per 6-inch	Moisture, %	STRENGTH, tsf	Additional Remarks
0	0						Approximately 1 1/2 inches of ASPHALT					
							Approximately 7 1/2 inches of CONCRETE					
				1	12		Brown and gray silty CLAY, trace sand and gravel		3,3			
				2	12			CL	5,4			
				3	12				6,7	22	×	
				4	12				14,12			
	5			5	6		End of hand auger at approximately 5 feet. No free groundwater encountered during drilling operation.		12			

Completion Depth: 5.0 ft	Sample Types:	Latitude: 41°53'6.85"N
Date Boring Started: 9/20/16	Auger Cutting	Longitude: 87°58'23.10"W
Date Boring Completed: 9/20/16	Split-Spoon	Drill Rig: Milwaukee Dymodrill Coring Machine
Logged By: T.R.	Rock Core	Remarks: Road Reconstruction
Drilling Contractor: Rubino Engineering, Inc.	Shelby Tube	
	Hand Auger	
	Texas Cone	

The stratification lines represent approximate boundaries. The transition may be gradual.

Rubino Job No.: G16.124	Drilling Method: Humboldt DCP + Hand Auger	WATER LEVELS	
Project: Proposed Sewer Separation and Road Reconstruction	Sampling Method: Grab Sample	▽ While Drilling	N/A
Location: Various Streets	Hammer Type: Humboldt DCP	▼ Upon Completion	N/A
City, State: Villa Park, Illinois	Boring Location: Central Boulevard Villa Park, Illinois	▽ Delay	N/A
Client: RJN Group			

Elevation (feet)	Depth (feet)	Graphic Log	Sample Type	Sample No.	Recovery (inches)	Station: N/A Offset: N/A	MATERIAL DESCRIPTION	USCS Classification	DCP Blows per 6-inch	Moisture, %	STRENGTH, tsf	Additional Remarks
0		Approximately 2 inches of ASPHALT										
		Approximately 7 inches of CONCRETE										
		Brown and gray silty CLAY with organics, trace sand and gravel		1	12				2,4			
				2	12			CL	4,4			
				3	12				7,8	25	←	LL = 46 PL = 23 10% Organic Content
				4	12				11,12			
5				5	6		End of hand auger at approximately 5 feet. No free groundwater encountered during drilling operation.		12			

Completion Depth: 5.0 ft	Sample Types:	Latitude: 41°53'7.72"N
Date Boring Started: 9/20/16	Auger Cutting	Longitude: 87°58'19.57"W
Date Boring Completed: 9/20/16	Split-Spoon	Drill Rig: Milwaukee Dymodrill Coring Machine
Logged By: T.R.	Rock Core	Remarks: Road Reconstruction
Drilling Contractor: Rubino Engineering, Inc.	Shelby Tube	
	Hand Auger	
	Texas Cone	

The stratification lines represent approximate boundaries. The transition may be gradual.

Rubino Job No.: G16.124	Drilling Method: Humboldt DCP + Hand Auger	WATER LEVELS
Project: Proposed Sewer Separation and Road Reconstruction	Sampling Method: Grab Sample	▽ While Drilling N/A
Location: Various Streets	Hammer Type: Humboldt DCP	▼ Upon Completion N/A
City, State: Villa Park, Illinois	Boring Location: Central Boulevard	▼ Delay N/A
Client: RJN Group	Villa Park, Illinois	

Elevation (feet)	Depth (feet)	Graphic Log	Sample Type	Sample No.	Recovery (inches)	Station: N/A Offset: N/A	MATERIAL DESCRIPTION	USCS Classification	DCP Blows per 6-inch	Moisture, %	STRENGTH, tsf	Additional Remarks
0		Approximately 1 1/2 inches of ASPHALT Approximately 8 1/2 inches of CONCRETE										
		Brown and gray silty CLAY with organics, trace sand and gravel		1	12				4,3			
				2	12			CL	4,4			
				3	12				5,8	24	←	LL = 44 PL = 22 11% Organic Content
				4	12				10,13			
5				5	6		End of hand auger at approximately 5 feet. No free groundwater encountered during drilling operation.		13			

Completion Depth: 5.0 ft	Sample Types:	Latitude: 41°53'8.40"N
Date Boring Started: 9/20/16	Auger Cutting	Longitude: 87°58'15.71"W
Date Boring Completed: 9/20/16	Split-Spoon	Drill Rig: Milwaukee Dymodrill Coring Machine
Logged By: T.R.	Rock Core	Remarks: Road Reconstruction
Drilling Contractor: Rubino Engineering, Inc.	Shelby Tube	
	Hand Auger	
	Texas Cone	

The stratification lines represent approximate boundaries. The transition may be gradual.

Rubino Job No.: G16.124	Drilling Method: Humboldt DCP + Hand Auger	WATER LEVELS
Project: Proposed Sewer Separation and Road Reconstruction	Sampling Method: Grab Sample	▽ While Drilling N/A
Location: Various Streets	Hammer Type: Humboldt DCP	▼ Upon Completion N/A
City, State: Villa Park, Illinois	Boring Location: Central Boulevard	▼ Delay N/A
Client: RJN Group	Villa Park, Illinois	

Elevation (feet)	Depth, (feet)	Graphic Log	Sample Type	Sample No.	Recovery (inches)	Station: N/A Offset: N/A	MATERIAL DESCRIPTION	USCS Classification	DCP Blows per 6-inch	Moisture, %	STRENGTH, tsf	Additional Remarks
0		Approximately 1 1/2 inches of ASPHALT										
		Approximately 8 inches of CONCRETE										
		Brown and gray silty CLAY with organics, trace sand and gravel		1	12				3,2			
				2	12			CL	3,4	19		LL = 39 PL = 19 10% Organic Content
				3	12				5,5			
				4	12				7,11			
5				5	6		End of hand auger at approximately 5 feet. No free groundwater encountered during drilling operation.		11			

Completion Depth: 5.0 ft	Sample Types:	Latitude: 41°53'9.49"N
Date Boring Started: 9/20/16	Auger Cutting	Longitude: 87°58'11.45"W
Date Boring Completed: 9/20/16	Split-Spoon	Drill Rig: Milwaukee Dymodrill Coring Machine
Logged By: T.R.	Rock Core	Remarks: Road Reconstruction
Drilling Contractor: Rubino Engineering, Inc.	Shelby Tube	
	Hand Auger	
	Texas Cone	

The stratification lines represent approximate boundaries. The transition may be gradual.

Rubino Job No.: G16.124
 Project: Proposed Sewer Separation and Road Reconstruction
 Location: Various Streets
 City, State: Villa Park, Illinois
 Client: RJN Group

Drilling Method: Humboldt DCP + Hand Auger
 Sampling Method: Grab Sample
 Hammer Type: Humboldt DCP
 Boring Location: Crescent Drive
 Villa Park, Illinois

WATER LEVELS	
▽ While Drilling	N/A
▼ Upon Completion	N/A
⚡ Delay	N/A

Elevation (feet)	Depth (feet)	Graphic Log	Sample Type	Sample No.	Recovery (inches)	MATERIAL DESCRIPTION	USCS Classification	DCP Blows per 6-inch	STANDARD PENETRATION TEST DATA		Additional Remarks	
									Moisture, %	Moisture, %		
0						Station: N/A Offset: N/A			0	25	50	
						Approximately 4 1/2 inches of ASPHALT						
						Approximately 4 1/2 inches of GRAVEL BASE						
				1	12	Brown and gray silty CLAY of medium to high plasticity with organics, trace sand and gravel		3,5				
				2	12			6,7				
				3	12		OH	11,8	33			LL = 58 PL = 33 26% Organic Content
				4	12			6,6				
5				5	6	End of hand auger at approximately 5 feet. No free groundwater encountered during drilling operation.		6				

Completion Depth: 5.0 ft
 Date Boring Started: 9/20/16
 Date Boring Completed: 9/20/16
 Logged By: T.R.
 Drilling Contractor: Rubino Engineering, Inc.

Sample Types:

Auger Cutting	Shelby Tube
Split-Spoon	Hand Auger
Rock Core	Texas Cone

Latitude: 41°53'5.61"N
 Longitude: 87°58'12.08"W
 Drill Rig: Milwaukee Dymodrill Coring Machine
 Remarks: Road Reconstruction

The stratification lines represent approximate boundaries. The transition may be gradual.

Rubino Job No.: G16.124	Drilling Method: Humboldt DCP + Hand Auger	WATER LEVELS
Project: Proposed Sewer Separation and Road Reconstruction	Sampling Method: Grab Sample	▽ While Drilling N/A
Location: Various Streets	Hammer Type: Humboldt DCP	▼ Upon Completion N/A
City, State: Villa Park, Illinois	Boring Location: Crescent Drive	▼ Delay N/A
Client: RJN Group	Villa Park, Illinois	

Elevation (feet)	Depth (feet)	Graphic Log	Sample Type	Sample No.	Recovery (inches)	Station: N/A Offset: N/A	MATERIAL DESCRIPTION	USCS Classification	DCP Blows per 6-inch	Moisture, %	STRENGTH, tsf	Additional Remarks
0		Approximately 3 inches of ASPHALT Approximately 13 inches of GRAVEL BASE										
		Brown and gray silty CLAY, trace sand and gravel		1	12				5,4			
				2	12			CL	3,5	24		LL = 40 PL = 15 9% Organic Content
				3	12				5,4			
				4	6				5			
5		End of hand auger at approximately 5 feet. No free groundwater encountered during drilling operation.										

Completion Depth: 5.0 ft	Sample Types:	Latitude: 41°53'5.82"N
Date Boring Started: 9/20/16	Auger Cutting	Longitude: 87°58'10.62"W
Date Boring Completed: 9/20/16	Split-Spoon	Drill Rig: Milwaukee Dymodrill Coring Machine
Logged By: T.R.	Rock Core	Remarks: Road Reconstruction
Drilling Contractor: Rubino Engineering, Inc.	Shelby Tube	
	Hand Auger	
	Texas Cone	

The stratification lines represent approximate boundaries. The transition may be gradual.

Rubino Job No.: G16.124	Drilling Method: Humboldt DCP + Hand Auger	WATER LEVELS	
Project: Proposed Sewer Separation and Road Reconstruction	Sampling Method: Grab Sample	▽ While Drilling	N/A
Location: Various Streets	Hammer Type: Humboldt DCP	▼ Upon Completion	N/A
City, State: Villa Park, Illinois	Boring Location: Myrtle Avenue	▼ Delay	N/A
Client: RJN Group	Villa Park, Illinois		

Elevation (feet)	Depth (feet)	Graphic Log	Sample Type	Sample No.	Recovery (inches)	Station: N/A Offset: N/A	MATERIAL DESCRIPTION	USCS Classification	DCP Blows per 6-inch	Moisture, %	STRENGTH, tsf	Additional Remarks
0							Approximately 1 1/2 inches of ASPHALT					
							Approximately 7 inches of CONCRETE					
				1	12		Brown and gray silty CLAY with organics, trace sand and gravel		5,6			
				2	12			CL	5,4			
				3	12				7,9	20		LL = 36 PL = 19 12% Organic Content
				4	12				10,11			
5				5	6		End of hand auger at approximately 5 feet. No free groundwater encountered during drilling operation.		11			

Completion Depth: 5.0 ft	Sample Types:	Latitude: 41°53'5.90"N
Date Boring Started: 9/20/16	Auger Cutting	Longitude: 87°58'13.50"W
Date Boring Completed: 9/20/16	Split-Spoon	Drill Rig: Milwaukee Dymodrill Coring Machine
Logged By: T.R.	Rock Core	Remarks: Road Reconstruction
Drilling Contractor: Rubino Engineering, Inc.	Shelby Tube	
	Hand Auger	
	Texas Cone	

The stratification lines represent approximate boundaries. The transition may be gradual.

Rubino Job No.: G16.124	Drilling Method: Humboldt DCP + Hand Auger	WATER LEVELS
Project: Proposed Sewer Separation and Road Reconstruction	Sampling Method: Grab Sample	▽ While Drilling N/A
Location: Various Streets	Hammer Type: Humboldt DCP	▼ Upon Completion N/A
City, State: Villa Park, Illinois	Boring Location: Myrtle Avenue	▼ Delay N/A
Client: RJN Group	Villa Park, Illinois	

Elevation (feet)	Depth (feet)	Graphic Log	Sample Type	Sample No.	Recovery (inches)	Station: N/A Offset: N/A	MATERIAL DESCRIPTION	USCS Classification	DCP Blows per 6-inch	Moisture, %	STRENGTH, tsf	Additional Remarks
0		Approximately 1 ¼ inches of ASPHALT										
		Approximately 7 ¼ inches of CONCRETE										
		Brown and gray silty CLAY, trace sand and gravel		1	12				4.5			
				2	12			CL	5.4			
				3	12				7.8	19	□	LL = 39 PL = 19 8% Organic Content
				4	12				11,13			
5				5	6		End of hand auger at approximately 5 feet. No free groundwater encountered during drilling operation.		13			

Completion Depth: 5.0 ft	Sample Types:	Latitude: 41°53'3.99"N
Date Boring Started: 9/20/16	Auger Cutting	Longitude: 87°58'13.36"W
Date Boring Completed: 9/20/16	Split-Spoon	Drill Rig: Milwaukee Dymodrill Coring Machine
Logged By: T.R.	Rock Core	Remarks: Road Reconstruction
Drilling Contractor: Rubino Engineering, Inc.	Shelby Tube	
	Hand Auger	
	Texas Cone	

The stratification lines represent approximate boundaries. The transition may be gradual.

Rubino Job No.: G16.124	Drilling Method: Humboldt DCP + Hand Auger	WATER LEVELS
Project: Proposed Sewer Separation and Road Reconstruction	Sampling Method: Grab Sample	▽ While Drilling N/A
Location: Various Streets	Hammer Type: Humboldt DCP	▼ Upon Completion N/A
City, State: Villa Park, Illinois	Boring Location: Myrtle Avenue	▼ Delay N/A
Client: RJN Group	Villa Park, Illinois	

Elevation (feet)	Depth, (feet)	Graphic Log	Sample Type	Sample No.	Recovery (inches)	Station: N/A Offset: N/A	MATERIAL DESCRIPTION	USCS Classification	DCP Blows per 6-inch	Moisture, %	STRENGTH, tsf	Additional Remarks
0		Approximately 1 ¼ inches of ASPHALT										
		Approximately 7 ¼ inches of CONCRETE										
		Brown and gray silty CLAY of high plasticity with organics, trace sand and gravel		1	12				4,3			
				2	12			CH	4,4	30		LL = 53 PL = 21 10% Organic Content
				3	12				3,5			
				4	12				11,12			
5				5	6		End of hand auger at approximately 5 feet. No free groundwater encountered during drilling operation.		12			

Completion Depth: 5.0 ft	Sample Types:	Latitude: 41°53'2.16"N
Date Boring Started: 9/20/16	Auger Cutting	Longitude: 87°58'13.48"W
Date Boring Completed: 9/20/16	Split-Spoon	Drill Rig: Milwaukee Dymodrill Coring Machine
Logged By: T.R.	Rock Core	Remarks: Road Reconstruction
Drilling Contractor: Rubino Engineering, Inc.	Shelby Tube	
	Hand Auger	
	Texas Cone	

The stratification lines represent approximate boundaries. The transition may be gradual.

Rubino Job No.: G16.124	Drilling Method: Humboldt DCP + Hand Auger	WATER LEVELS	
Project: Proposed Sewer Separation and Road Reconstruction	Sampling Method: Grab Sample	▽ While Drilling	N/A
Location: Various Streets	Hammer Type: Humboldt DCP	▼ Upon Completion	N/A
City, State: Villa Park, Illinois	Boring Location: Myrtle Avenue	▽ Delay	N/A
Client: RJN Group	Villa Park, Illinois		

Elevation (feet)	Depth, (feet)	Graphic Log	Sample Type	Sample No.	Recovery (inches)	Station: N/A Offset: N/A	MATERIAL DESCRIPTION	USCS Classification	DCP Blows per 6-inch	Moisture, %	STRENGTH, tsf	Additional Remarks
0		Approximately 1 3/4 inches of ASPHALT Approximately 9 3/4 inches of CONCRETE										
		Brown and gray silty CLAY, trace sand and gravel		1	12				4,3			
				2	12			CL	3,3	21		LL = 40 PL = 18 7% Organic Content
				3	12				3,12			
				4	12				12,12			
5							End of hand auger at approximately 5 feet. No free groundwater encountered during drilling operation.					

Completion Depth: 5.0 ft	Sample Types:	Latitude: 41°52'59.90"N
Date Boring Started: 9/20/16	Auger Cutting	Longitude: 87°58'13.24"W
Date Boring Completed: 9/20/16	Split-Spoon	Drill Rig: Milwaukee Dymodrill Coring Machine
Logged By: T.R.	Rock Core	Remarks: Road Reconstruction
Drilling Contractor: Rubino Engineering, Inc.	Shelby Tube	
	Hand Auger	
	Texas Cone	

The stratification lines represent approximate boundaries. The transition may be gradual.

Rubino Job No.: G16.124	Drilling Method: Humboldt DCP + Hand Auger	WATER LEVELS
Project: Proposed Sewer Separation and Road Reconstruction	Sampling Method: Grab Sample	▽ While Drilling N/A
Location: Various Streets	Hammer Type: Humboldt DCP	▼ Upon Completion N/A
City, State: Villa Park, Illinois	Boring Location: Astor Court	▼ Delay N/A
Client: RJN Group	Villa Park, Illinois	

Elevation (feet)	Depth (feet)	Graphic Log	Sample Type	Sample No.	Recovery (inches)	Station: N/A Offset: N/A	MATERIAL DESCRIPTION	USCS Classification	DCP Blows per 6-inch	Moisture, %	STRENGTH, tsf	Additional Remarks
0		Approximately 2 inches of ASPHALT										
		Approximately 6 1/2 inches of CONCRETE										
		Brown and gray silty CLAY of high plasticity, trace sand and gravel		1	12				4,4			
				2	12			CH	5,6	20		LL = 54 PL = 20 8% Organic Content
				3	12				7,9			
				4	12				9,13			
5				5	6		End of hand auger at approximately 5 feet. No free groundwater encountered during drilling operation.		13			

Completion Depth: 5.0 ft	Sample Types:	Latitude: 41°53'1.59"N
Date Boring Started: 9/20/16	Auger Cutting	Longitude: 87°58'23.93"W
Date Boring Completed: 9/20/16	Split-Spoon	Drill Rig: Milwaukee Dymodrill Coring Machine
Logged By: T.R.	Rock Core	Remarks: Road Reconstruction
Drilling Contractor: Rubino Engineering, Inc.	Shelby Tube	
	Hand Auger	
	Texas Cone	

The stratification lines represent approximate boundaries. The transition may be gradual.

Rubino Job No.: G16.124	Drilling Method: Humboldt DCP + Hand Auger	WATER LEVELS	
Project: Proposed Sewer Separation and Road Reconstruction	Sampling Method: Grab Sample	▽ While Drilling	N/A
Location: Various Streets	Hammer Type: Humboldt DCP	▼ Upon Completion	N/A
City, State: Villa Park, Illinois	Boring Location: Astor Court	▼ Delay	N/A
Client: RJN Group	Villa Park, Illinois		

Elevation (feet)	Depth (feet)	Graphic Log	Sample Type	Sample No.	Recovery (inches)	Station: N/A Offset: N/A	MATERIAL DESCRIPTION	USCS Classification	DCP Blows per 6-inch	Moisture, %	STRENGTH, tsf	Additional Remarks
0		Approximately 1 ¼ inches of ASPHALT										
		Approximately 6 ¾ inches of CONCRETE										
		Brown and gray silty CLAY of high plasticity, trace sand and gravel		1	12				2,4			
				2	12			CH	4,6			
				3	12				8,12	22	■	LL = 61 PL = 22 9% Organic Content
				4	12				14,14			
				5	6				14			
							End of hand auger at approximately 5 feet. No free groundwater encountered during drilling operation.					

Completion Depth: 5.0 ft	Sample Types:	Latitude: 41°53'1.54"N
Date Boring Started: 9/20/16	Auger Cutting	Longitude: 87°58'21.47"W
Date Boring Completed: 9/20/16	Split-Spoon	Drill Rig: Milwaukee Dymodrill Coring Machine
Logged By: T.R.	Rock Core	Remarks: Road Reconstruction
Drilling Contractor: Rubino Engineering, Inc.	Shelby Tube	
	Hand Auger	
	Texas Cone	

The stratification lines represent approximate boundaries. The transition may be gradual.

Rubino Job No.: G16.124	Drilling Method: Humboldt DCP + Hand Auger	WATER LEVELS
Project: Proposed Sewer Separation and Road Reconstruction	Sampling Method: Grab Sample	▽ While Drilling N/A
Location: Various Streets	Hammer Type: Humboldt DCP	▼ Upon Completion N/A
City, State: Villa Park, Illinois	Boring Location: Astor Court	▽ Delay N/A
Client: RJN Group	Villa Park, Illinois	

Elevation (feet)	Depth (feet)	Graphic Log	Sample Type	Sample No.	Recovery (inches)	Station: N/A Offset: N/A	MATERIAL DESCRIPTION	USCS Classification	DCP Blows per 6-inch	Moisture, %	STRENGTH, tsf	Additional Remarks
0		Approximately 2 ¼ inches of ASPHALT										
		Approximately 6 ¼ inches of CONCRETE										
		Brown and gray silty CLAY with organics, trace sand and gravel		1	12				6,6			
				2	12			CL	5,8			
				3	12				8,13	19	□ — □	LL = 42 PL = 19 10% Organic Content
				4	12				15,16			
				5	6				16			
		End of hand auger at approximately 5 feet. No free groundwater encountered during drilling operation.										

Completion Depth: 5.0 ft	Sample Types:	Latitude: 41°53'1.67"N
Date Boring Started: 9/20/16	Auger Cutting	Longitude: 87°58'18.69"W
Date Boring Completed: 9/20/16	Split-Spoon	Drill Rig: Milwaukee Dymodrigl Coring Machine
Logged By: T.R.	Rock Core	Remarks: Road Reconstruction
Drilling Contractor: Rubino Engineering, Inc.	Shelby Tube	
	Hand Auger	
	Texas Cone	

The stratification lines represent approximate boundaries. The transition may be gradual.

Rubino Job No.: G16.124	Drilling Method: Humboldt DCP + Hand Auger	WATER LEVELS	
Project: Proposed Sewer Separation and Road Reconstruction	Sampling Method: Grab Sample	▽ While Drilling	N/A
Location: Various Streets	Hammer Type: Humboldt DCP	▼ Upon Completion	N/A
City, State: Villa Park, Illinois	Boring Location: Astor Court	▼ Delay	N/A
Client: RJN Group	Villa Park, Illinois		

Elevation (feet)	Depth (feet)	Graphic Log	Sample Type	Sample No.	Recovery (inches)	Station: N/A Offset: N/A	MATERIAL DESCRIPTION	USCS Classification	DCP Blows per 6-inch	Moisture, %	STRENGTH, tsf	Additional Remarks
0							Approximately 2 1/2 inches of ASPHALT Approximately 6 1/2 inches of CONCRETE					
				1	12		Brown and gray silty CLAY, trace sand and gravel		3,3			
				2	12			CL	5,4			
				3	12				6,7	22	×	
				4	12				14,12			
5				5	6		End of hand auger at approximately 5 feet. No free groundwater encountered during drilling operation.		12			

Completion Depth: 5.0 ft	Sample Types:	Latitude: 41°53'1.58"N
Date Boring Started: 9/20/16	Auger Cutting	Longitude: 87°58'15.94"W
Date Boring Completed: 9/20/16	Split-Spoon	Drill Rig: Milwaukee Dymodrill Coring Machine
Logged By: T.R.	Rock Core	Remarks: Road Reconstruction
Drilling Contractor: Rubino Engineering, Inc.	Shelby Tube	
	Hand Auger	
	Texas Cone	

The stratification lines represent approximate boundaries. The transition may be gradual.

APPENDIX G – LABORATORY RESULTS

NOT FOR BID

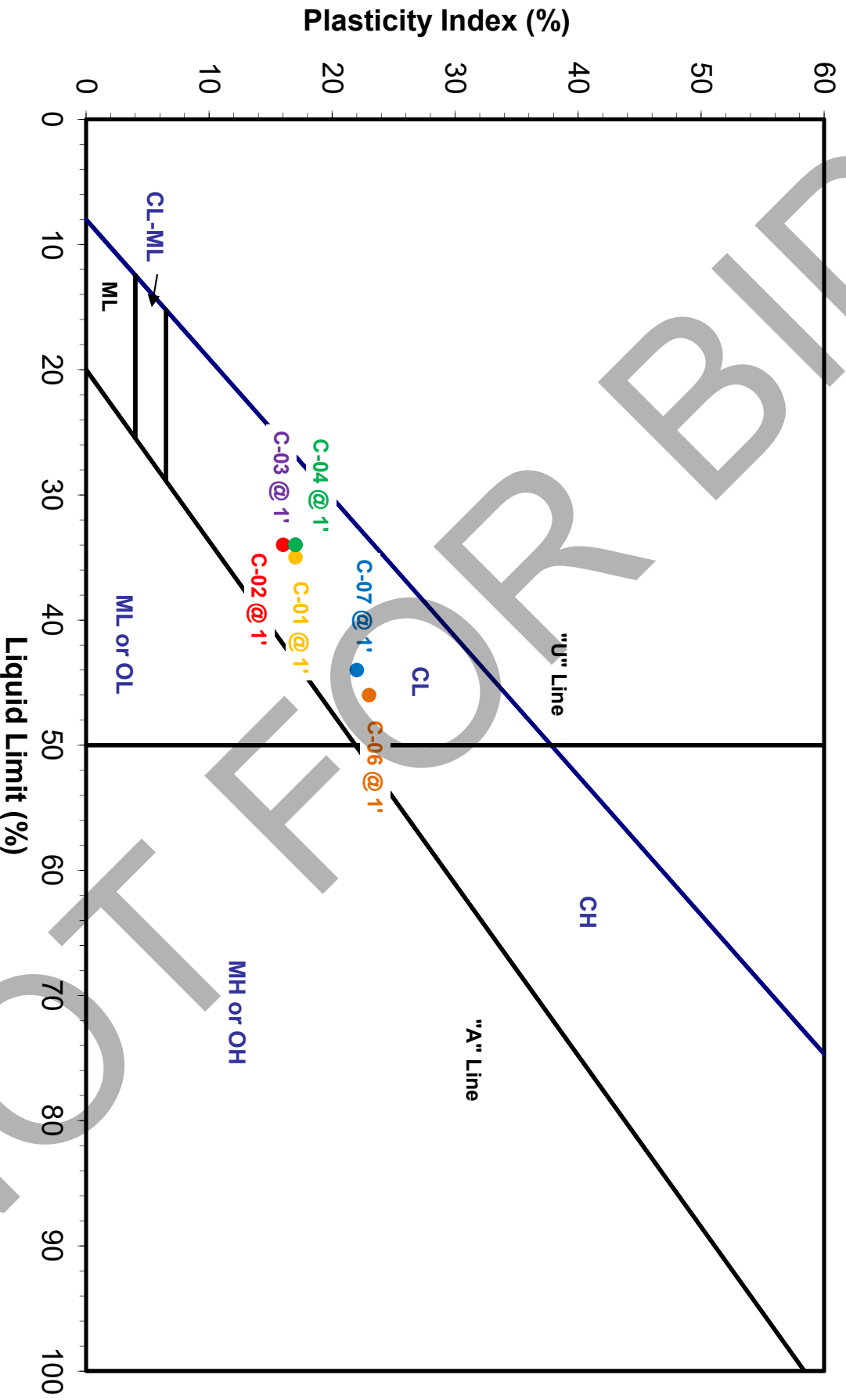

Boring #	C-01 @ 1'	C-02 @ 1'	C-03 @ 1'	C-04 @ 1'	C-06 @ 1'	C-07 @ 1'	Project: Proposed Sewer Separation and Road Reconstruction	
LL	35	34	34	34	46	44	Location: Villa Park, Illinois	
PL	18	18	17	17	23	22	Client: RJN Group, Inc.	
PI	17	16	17	17	23	22	Project #: G16.124	

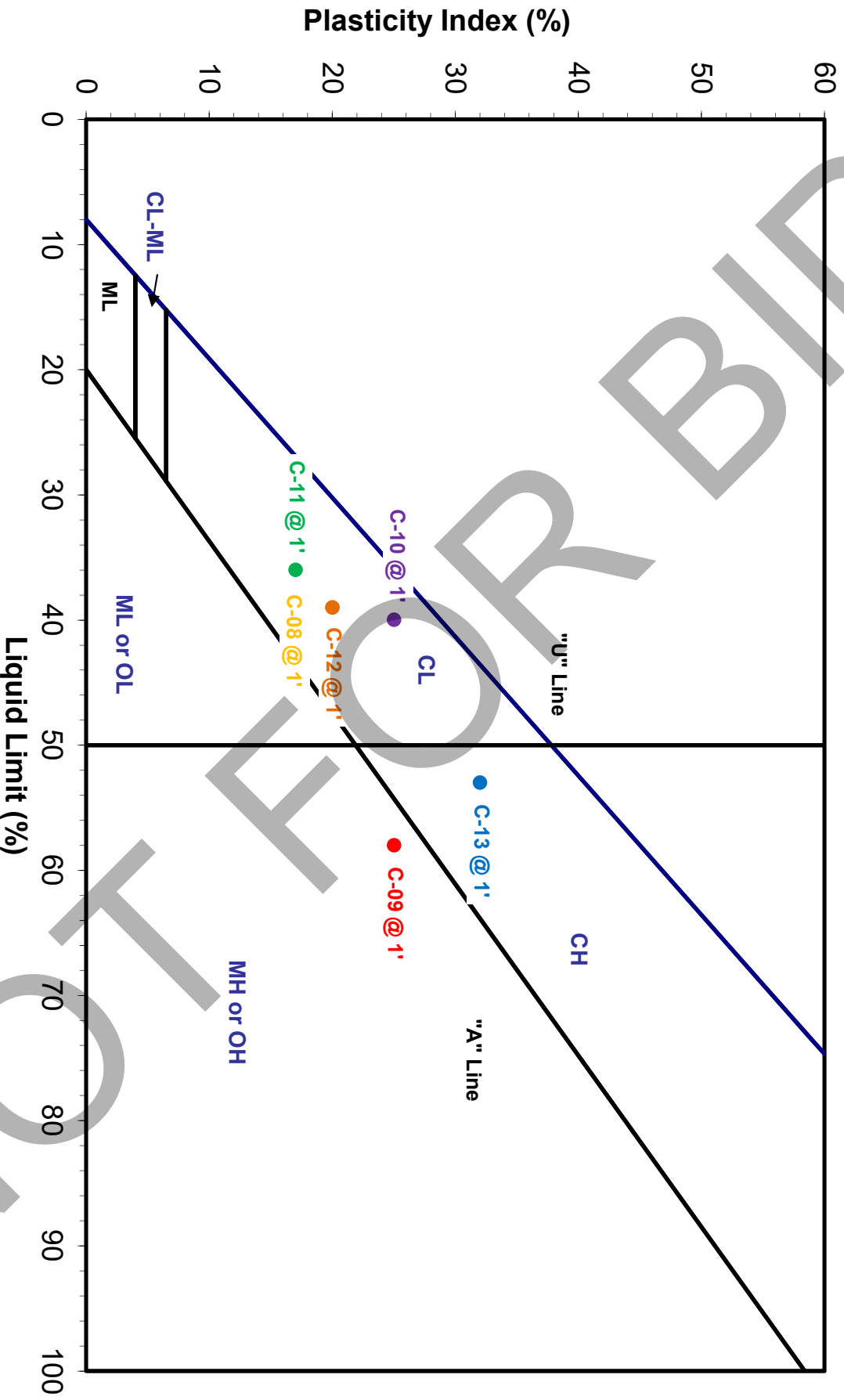

Boring #	C-08 @ 1'	C-09 @ 1'	C-10 @ 1'	C-11 @ 1'	C-12 @ 1'	C-13 @ 1'
LL	39	58	40	36	39	53
PL	19	33	15	19	19	21
PI	20	25	25	17	20	32

Project: Proposed Sewer Separation and Road Reconstruction
Location: Villa Park, Illinois
Client: RJN Group, Inc.
Project #: G16.124

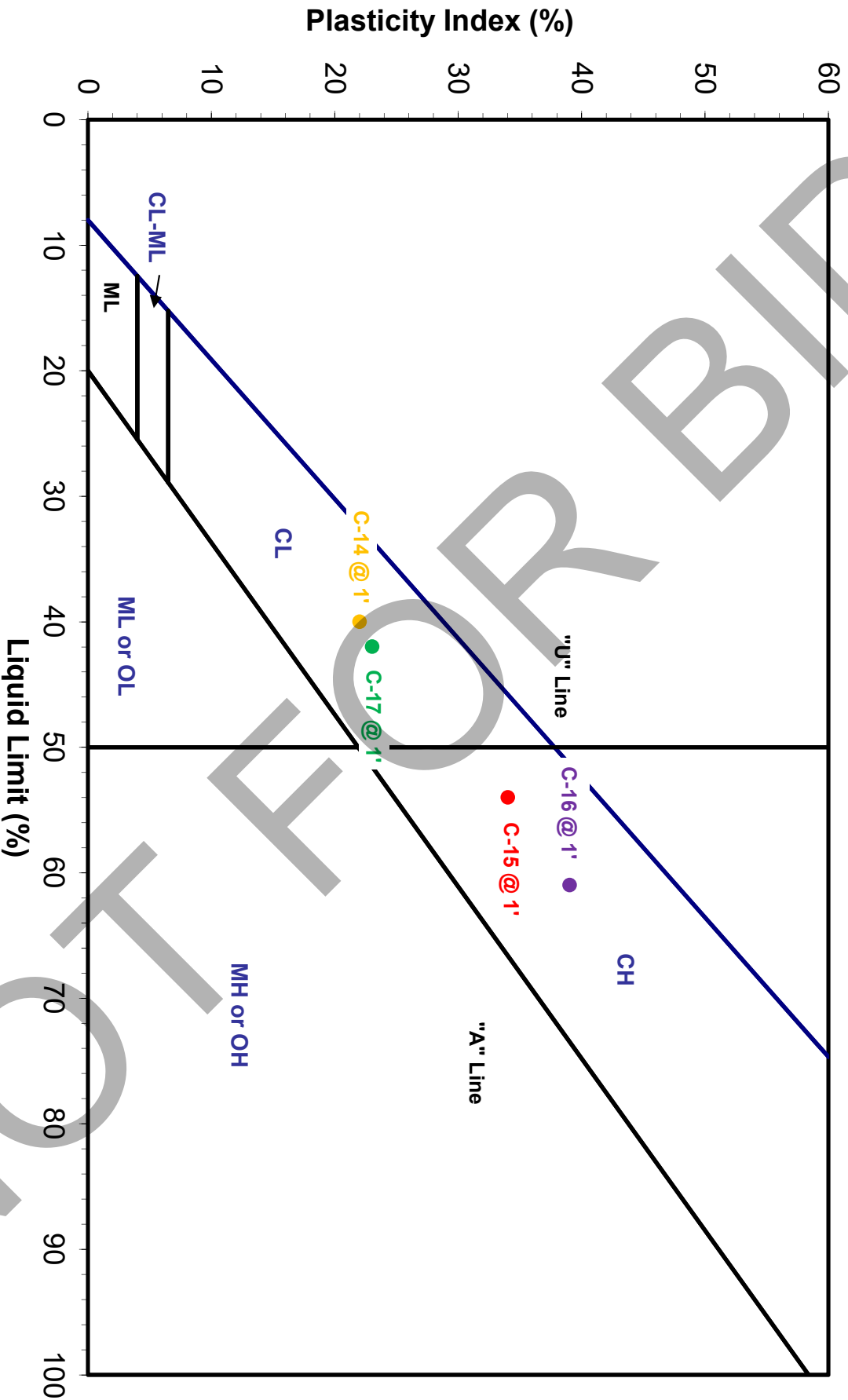

Boring #	C-14 @ 1'	C-15 @ 1'	C-16 @ 1'	C-17 @ 1'
LL	40	54	61	42
PL	18	20	22	19
PI	22	34	39	23

Project: Proposed Sewer Separation and Road Reconstruction
Location: Villa Park, Illinois
Client: RJN Group, Inc.
Project #: G16.124



Bureau of Land • 1021 North Grand Avenue East • P.O. Box 19276 • Springfield • Illinois • 62794-9276

Source Site Certification by Owner or Operator for Use of Uncontaminated Soil as Fill in a CCDD or Uncontaminated Soil Fill Operation LPC-662

Revised in accordance with 35 Ill. Adm. Code 1100, as
amended by PCB R2012-009 (eff. Aug. 27, 2012)

This certification form is to be used by source site owners and operators to certify, pursuant to 35 Ill. Adm. Code 1100.205(a)(1) (A), that soil (i) was removed from a site that is not potentially impacted property and is presumed to be uncontaminated soil and (ii) is within a pH range of 6.25 to 9.0. If you have questions about this form, please telephone the Bureau of Land Permit Section at 217/524-3300.

This form may be completed online, saved locally, printed and signed, and submitted to prospective clean construction or demolition debris fill operations or uncontaminated soil fill operations.

I. Source Location Information

(Describe the location of the source of the uncontaminated soil)

Project Name: Villa Park Road Reconstruction/Utility Improvements Office Phone Number, if available: _____

Physical Site Location (Street, Road): Astor Ct. /Myrtle Ave. /Crescent Dr.

City: Villa Park State: IL Zip Code: 60181

County: DuPage Township: _____

Lat/Long of approximate center of site in decimal degrees (DD.ddddd) to five decimal places (e.g., 40.67890, -90.12345):

Latitude: 41.883955 Longitude: -87.970370
(Decimal Degrees) (-Decimal Degrees)

Identify how the lat/long data were determined:

- GPS Map Interpolation Photo Interpolation Survey Other

IEPA Site Number(s), if assigned: _____ BOL: _____ BOW: _____ BOA: _____

II. Owner/Operator Information for Source Site

Site Owner

Site Operator

Name: Village of Villa Park

Name: _____

Street Address: 20 S. Ardmore Ave.

Street Address: _____

PO Box: _____

PO Box: _____

City: Villa Park State: IL

City: _____ State: _____

Zip Code: 60181 Phone: 630.834.8500

Zip Code: _____ Phone: _____

Contact: _____

Contact: _____

Email, if available: _____

Email, if available: _____

This Agency is authorized to require this information under Section 4 and Title X of the Environmental Protection Act (415 ILCS 5/4, 5/39). Failure to disclose this information may result in: a civil penalty of not to exceed \$50,000 for the violation and an additional civil penalty of not to exceed \$10,000 for each day during which the violation continues (415 ILCS 5/42). This form has been approved by

Project Name: Villa Park Road Reconstruction/Utility ImprovementsLatitude: 41.883955 Longitude: -87.970370
(Decimal Degrees) (-Decimal Degrees)**Source Site Certification****III. Descriptions of Current and Past Uses of Source Site**

Describe the current and past uses of the site and nearby properties.* Attach additional information as needed. The description must take into account, at a minimum, the following for the source site and for nearby property: (1) use of the properties for commercial or industrial purposes; (2) the use, storage or disposal of chemical or petroleum products in individual containers greater than 5 gallons or collectively more than 50 gallons; (3) the current or past presence of any storage tanks (above ground or underground); (4) any waste storage, treatment or disposal at the properties; (5) any reported releases or any environmental cleanup or removal of contaminants; (6) any environmental liens or governmental notification of environmental violations; (7) any contamination in a well that exceeds the Board's groundwater quality standards; (8) the use, storage, or disposal of transformers or capacitors manufactured before 1979; and (9) any fill dirt brought to the properties from an unknown source or site.

Number of pages attached: 43

Refer to certification statement in section A.1b.

*The description must be sufficient to demonstrate that the source site is not potentially impacted property, thereby allowing the source site owner or operator to provide this certification.

IV. Soil pH Testing Results

Describe the results of soil pH testing showing that the soil pH is within the range of 6.25 to 9.0 and attach any supporting documentation.

Number of pages attached: 1

One sample was collected and tested for pH. Result of the pH test was within the range of 6.25 to 9.0 and are attached.

V. Source Site Owner, Operator or Authorized Representative's Certification Statement and Signature

In accordance with the Illinois Environmental Protection Act [415 ILCS 5/22.51 or 22.51a] and 35 Ill. Adm. Code 1100.205(a), I Gregory W. Wilcox P.E. Winston Engineering (owner, operator or authorized representative of source site) certify that this site is not a potentially impacted property and the soil is presumed to be uncontaminated soil. I also certify that the soil pH is within the range of 6.25 to 9.0. I further certify that the soil has not been removed from the site as part of a cleanup or removal of contaminants. Additionally, I certify that I am either the site owner or operator or a duly authorized representative of the site owner or site operator and am authorized to sign this form. Furthermore, I certify that all information submitted, including but not limited to, all attachments and other information, is to the best of my knowledge and belief, true, accurate and complete.

Any person who knowingly makes a false, fictitious, or fraudulent material statement, orally or in writing, to the Illinois EPA commits a Class 4 felony. A second or subsequent offense after conviction is a Class 3 felony. (415 ILCS 5/44(h))

 Owner Operator Owner's Duly Authorized Representative Operator's Duly Authorized Representative

Gregory W. Wilcox P.E. Winston Engineering
Printed Name

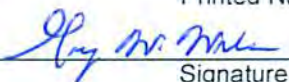
Signature

10/5/16
Date

Appendix A.1a

Certification statement

NOT FOR BID

A.1b

Villa Park Road Reconstruction/Utility Improvements

Astor Ct. /Myrtle Ave. /Crescent Dr.

Villa Park, IL 60181

Environmental Report 10/5/16

Environmental Database Review

On 9/16/16, Winston Engineering mobilized to conduct a site investigation of the material originally generated from the project located on Astor Ct., Myrtle Ave., and Crescent Dr. in Villa Park. A site investigation and Environmental Database Review concluded that the project site has a low probability of being environmental concerns. Environmental Database Report can be found in section A.4b.

Based on the low probability of environmental concerns and shallow excavation depths, the determination was made that pH sampling of the streets was necessary.

Soil Sampling

On 9/28/16 Winston Engineering collected one sample at an approximate depth of 5 ft below grade. The report of the pH test can be found in A.3b.

Conclusion

The pH result of the soil sample was 7.91 which is within the accepted pH range of 6.25 to 9.0 for CCDD or USFO disposal.

Appendix A.2

A.2b Site Map

A.2c-Site Map (With pH soil boring location)

NOT FOR BID

Villa Park Road Recon/Utility Improvements

A.2b Project Location

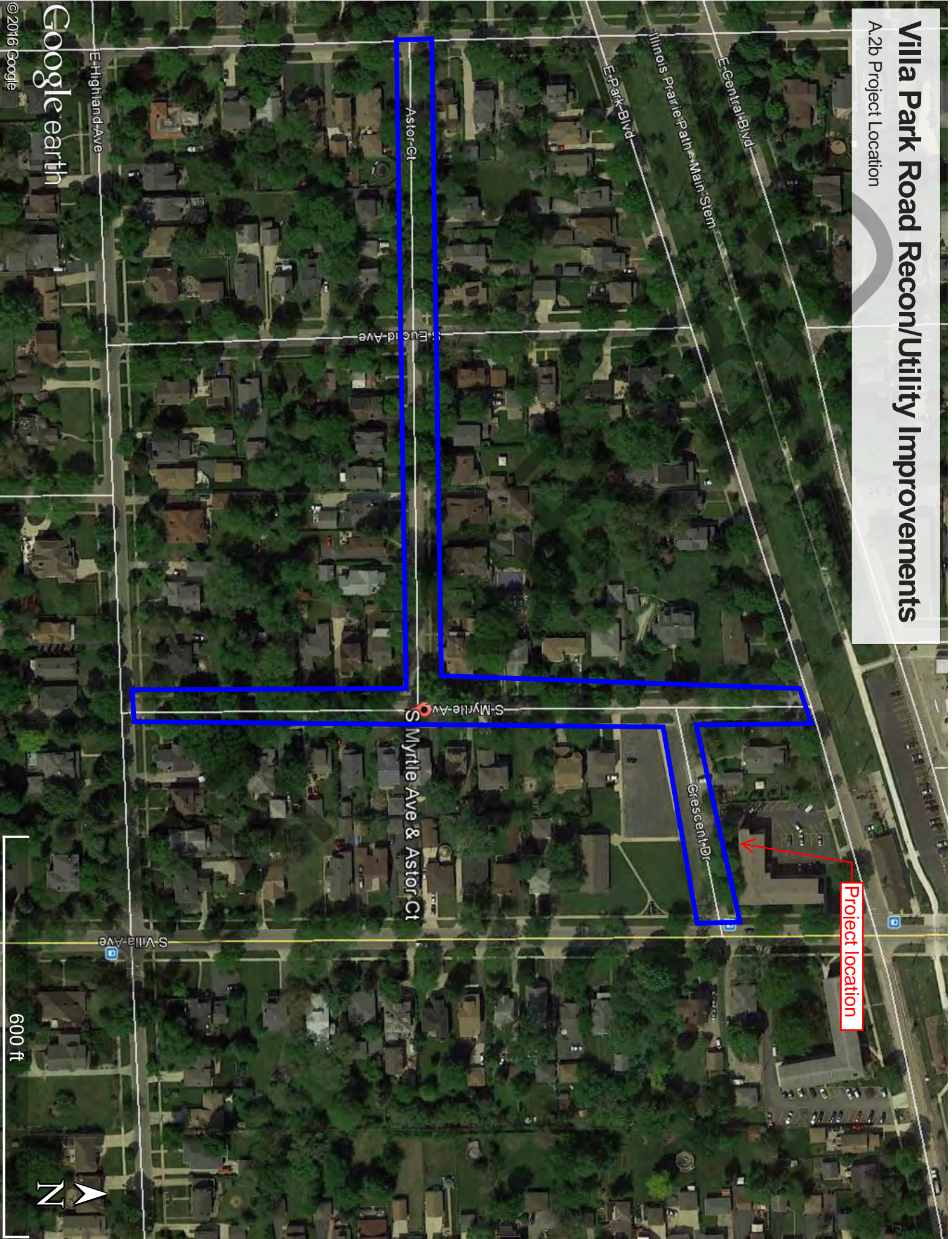

Project location

Grescent Dr

S Myrtle Ave
S Myrtle Ave & Astor Ct

Astor Ct

Eugene Ave

E Highland Ave

S Villa Ave

Google earth

© 2016 Google

600 ft



Villa Park Road Recon/Utility Improvements

A.2.c Project Location with pH boring location

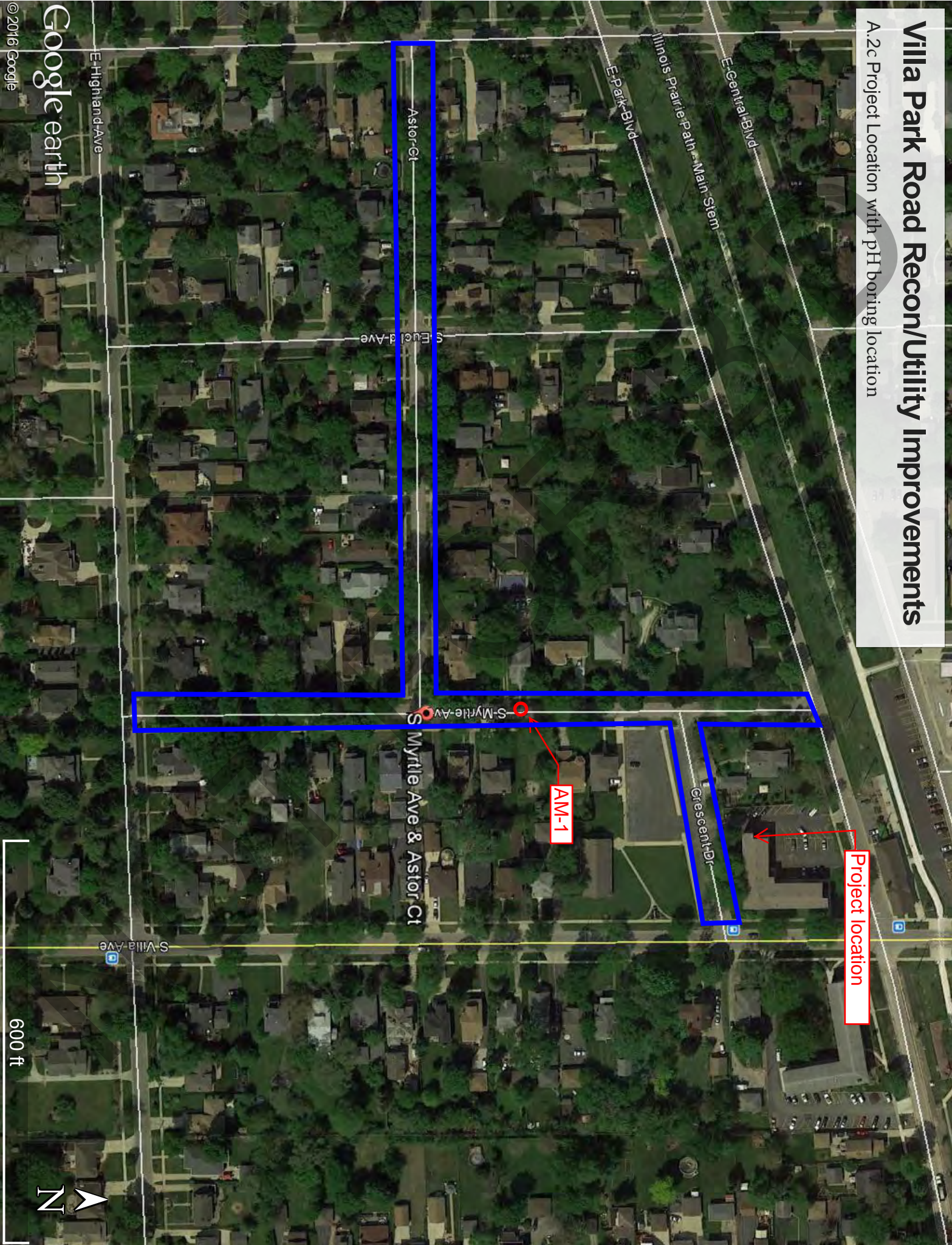

Project location

AM-1

Astor Ct

S Euclid Ave

S Myrtle Ave

S Myrtle Ave & Astor Ct

Grescent Dr

E Highland Ave

E Park Blvd

E Central Blvd

Illinois Prairie Path
Main Street

S Villa Ave

Google earth

© 2016 Google

600 ft



Appendix A.3

A.3b pH Results

NOT FOR BID

**WINSTON ENGINEERING**

2256 Southwind Blvd
Bartlett, IL 60103
Phone: 630-503-5028
Fax: 630-524-9020

Sampled By:

- Winston Engineering
 Customer
 Other: _____

Customer Name	Project Name	Project Location	Date Collected	Test Performed By	Date Tested
Rubino Engineering	Villa Park Road Reconstruction/Utility Improvements	Astor Ct. /Myrtle Ave. /Crescent Dr. Villa Park	9/28/16	AP	9/28/16

pH Meter Mfg: Oakton Instruments
Model #: pH 110 Meter

Method Used: NY Dot GTM-24
Calibration: Time:2:30pm Date:9/28

pH Test Results

Soil Sample Number	Soil Sample Name	Sample Matrix	Sample Type	Temp (°C)	pH Test Result
1	AM-1	Solid	Soil	19.8	7.91

Analyst
Signature: _____

Title: Environmental Scientist

Should you have any questions regarding your pH test results, or need additional information please call us at (630) 503-5028

Appendix A.4

EDR Report

NOT FOR BID

EDR VISTACheck® Report

Bluff City Materials, Inc.
267 S Myrtle Ave
villa park, IL 60181

A.4b EDR Report

Latitude (North): 41.884457 - 41°53'04.0452"
Longitude (West): 87.970376 - 87°58'13.3536"

October 05, 2016



Nationwide Customer Service
Telephone: 1-800-352-0050
Internet: www.edrnet.com



- ★ Target Property
- ▲ Sites
- National Priority List Sites
- Dept. Defense Sites
- Indian Reservations BIA

EDR VISTACheck® Report

<u>SECTION</u>	<u>PAGE</u>
Map Findings Summary	3
Map Findings	7
Orphan Summary	36

Disclaimer - Copyright and Trademark Notice

This Report contains certain information obtained from a variety of public and other sources reasonably available to Environmental Data Resources, Inc. It cannot be concluded from this Report that coverage information for the target and surrounding properties does not exist from other sources. **NO WARRANTY EXPRESSED OR IMPLIED, IS MADE WHATSOEVER IN CONNECTION WITH THIS REPORT. ENVIRONMENTAL DATA RESOURCES, INC. SPECIFICALLY DISCLAIMS THE MAKING OF ANY SUCH WARRANTIES, INCLUDING WITHOUT LIMITATION, MERCHANTABILITY OR FITNESS FOR A PARTICULAR USE OR PURPOSE. ALL RISK IS ASSUMED BY THE USER. IN NO EVENT SHALL ENVIRONMENTAL DATA RESOURCES, INC. BE LIABLE TO ANYONE, WHETHER ARISING OUT OF ERRORS OR OMISSIONS, NEGLIGENCE, ACCIDENT OR ANY OTHER CAUSE, FOR ANY LOSS OF DAMAGE, INCLUDING, WITHOUT LIMITATION, SPECIAL, INCIDENTAL, CONSEQUENTIAL, OR EXEMPLARY DAMAGES. ANY LIABILITY ON THE PART OF ENVIRONMENTAL DATA RESOURCES, INC. IS STRICTLY LIMITED TO A REFUND OF THE AMOUNT PAID FOR THIS REPORT.** Purchaser accepts this Report "AS IS". Any analyses, estimates, ratings, environmental risk levels or risk codes provided in this Report are provided for illustrative purposes only, and are not intended to provide, nor should they be interpreted as providing any facts regarding, or prediction or forecast of, any environmental risk for any property. Only a Phase I Environmental Site Assessment performed by an environmental professional can provide information regarding the environmental risk for any property. Additionally, the information provided in this Report is not to be construed as legal advice.

Copyright 2016 by Environmental Data Resources, Inc. All rights reserved. Reproduction in any media or format, in whole or in part, of any report or map of Environmental Data Resources, Inc., or its affiliates, is prohibited without prior written permission.

EDR and its logos (including Sanborn and Sanborn Map) are trademarks of Environmental Data Resources, Inc. or its affiliates. All other trademarks used herein are the property of their respective owners.

MAP FINDINGS SUMMARY

Database	Search Distance (Miles)	Target Property	< 1/8	1/8 - 1/4	1/4 - 1/2	1/2 - 1	> 1	Total Plotted
STANDARD ENVIRONMENTAL RECORDS								
Federal NPL site list								
NPL	0.500		0	0	0	NR	NR	0
Proposed NPL	0.500		0	0	0	NR	NR	0
NPL LIENS	TP		NR	NR	NR	NR	NR	0
Federal Delisted NPL site list								
Delisted NPL	0.500		0	0	0	NR	NR	0
Federal CERCLIS list								
FEDERAL FACILITY	0.500		0	0	0	NR	NR	0
SEMS	0.500		0	0	0	NR	NR	0
Federal CERCLIS NFRAP site list								
SEMS-ARCHIVE	0.500		0	0	0	NR	NR	0
Federal RCRA CORRACTS facilities list								
CORRACTS	0.500		0	0	0	NR	NR	0
Federal RCRA non-CORRACTS TSD facilities list								
RCRA-TSDF	0.500		0	0	0	NR	NR	0
Federal RCRA generators list								
RCRA-LQG	0.250		0	0	NR	NR	NR	0
RCRA-SQG	0.250		0	1	NR	NR	NR	1
RCRA-CESQG	0.250		0	0	NR	NR	NR	0
Federal institutional controls / engineering controls registries								
LUCIS	0.500		0	0	0	NR	NR	0
US ENG CONTROLS	0.500		0	0	0	NR	NR	0
US INST CONTROL	0.500		0	0	0	NR	NR	0
Federal ERNS list								
ERNS	TP		NR	NR	NR	NR	NR	0
State- and tribal - equivalent CERCLIS								
SSU	0.500		0	0	0	NR	NR	0
State and tribal landfill and/or solid waste disposal site lists								
SWF/LF	0.500		0	0	2	NR	NR	2
CCDD	0.500		0	0	0	NR	NR	0
LF SPECIAL WASTE	0.500		0	0	0	NR	NR	0
IL NIPC	0.500		0	0	0	NR	NR	0
State and tribal leaking storage tank lists								
LUST	0.500		0	4	7	NR	NR	11

MAP FINDINGS SUMMARY

Database	Search Distance (Miles)	Target Property	< 1/8	1/8 - 1/4	1/4 - 1/2	1/2 - 1	> 1	Total Plotted
INDIAN LUST	0.500		0	0	0	NR	NR	0
LUST TRUST	0.500		0	0	0	NR	NR	0
State and tribal registered storage tank lists								
FEMA UST	0.250		0	0	NR	NR	NR	0
UST	0.250		1	3	NR	NR	NR	4
AST	0.250		0	0	NR	NR	NR	0
INDIAN UST	0.250		0	0	NR	NR	NR	0
State and tribal institutional control / engineering control registries								
ENG CONTROLS	0.500		0	0	1	NR	NR	1
INST CONTROL	0.500		0	1	1	NR	NR	2
State and tribal voluntary cleanup sites								
INDIAN VCP	0.500		0	0	0	NR	NR	0
SRP	0.500		0	1	1	NR	NR	2
State and tribal Brownfields sites								
BROWNFIELDS	0.500		0	0	0	NR	NR	0
ADDITIONAL ENVIRONMENTAL RECORDS								
Local Brownfield lists								
US BROWNFIELDS	0.500		0	0	0	NR	NR	0
Local Lists of Landfill / Solid Waste Disposal Sites								
INDIAN ODI	0.500		0	0	0	NR	NR	0
ODI	0.500		0	0	0	NR	NR	0
DEBRIS REGION 9	0.500		0	0	0	NR	NR	0
Local Lists of Hazardous waste / Contaminated Sites								
US HIST CDL	TP		NR	NR	NR	NR	NR	0
CDL	TP		NR	NR	NR	NR	NR	0
US CDL	TP		NR	NR	NR	NR	NR	0
Local Land Records								
LIENS 2	TP		NR	NR	NR	NR	NR	0
Records of Emergency Release Reports								
HMIRS	TP		NR	NR	NR	NR	NR	0
SPILLS	TP		NR	NR	NR	NR	NR	0
Other Ascertainable Records								
RCRA NonGen / NLR	TP		NR	NR	NR	NR	NR	0
FUDS	0.500		0	0	0	NR	NR	0
DOD	0.500		0	0	0	NR	NR	0
SCRD DRYCLEANERS	0.500		0	0	0	NR	NR	0

MAP FINDINGS SUMMARY

Database	Search Distance (Miles)	Target Property	< 1/8	1/8 - 1/4	1/4 - 1/2	1/2 - 1	> 1	Total Plotted
US FIN ASSUR	TP		NR	NR	NR	NR	NR	0
EPA WATCH LIST	TP		NR	NR	NR	NR	NR	0
2020 COR ACTION	0.250		0	0	NR	NR	NR	0
TSCA	TP		NR	NR	NR	NR	NR	0
TRIS	TP		NR	NR	NR	NR	NR	0
SSTS	TP		NR	NR	NR	NR	NR	0
ROD	0.500		0	0	0	NR	NR	0
RMP	TP		NR	NR	NR	NR	NR	0
RAATS	TP		NR	NR	NR	NR	NR	0
PRP	TP		NR	NR	NR	NR	NR	0
PADS	TP		NR	NR	NR	NR	NR	0
ICIS	TP		NR	NR	NR	NR	NR	0
FTTS	TP		NR	NR	NR	NR	NR	0
MLTS	TP		NR	NR	NR	NR	NR	0
COAL ASH DOE	TP		NR	NR	NR	NR	NR	0
COAL ASH EPA	0.500		0	0	0	NR	NR	0
PCB TRANSFORMER	TP		NR	NR	NR	NR	NR	0
RADINFO	TP		NR	NR	NR	NR	NR	0
HIST FTTS	TP		NR	NR	NR	NR	NR	0
DOT OPS	TP		NR	NR	NR	NR	NR	0
CONSENT	0.500		0	0	0	NR	NR	0
INDIAN RESERV	0.500		0	0	0	NR	NR	0
FUSRAP	1.000		0	0	0	0	NR	0
UMTRA	0.500		0	0	0	NR	NR	0
LEAD SMELTERS	TP		NR	NR	NR	NR	NR	0
US AIRS	TP		NR	NR	NR	NR	NR	0
US MINES	0.250		0	0	NR	NR	NR	0
FINDS	TP		NR	NR	NR	NR	NR	0
UXO	1.000		0	0	0	0	NR	0
DOCKET HWC	TP		NR	NR	NR	NR	NR	0
AIRS	TP		NR	NR	NR	NR	NR	0
BOL	TP		NR	NR	NR	NR	NR	0
CHICAGO ENV	TP		NR	NR	NR	NR	NR	0
COAL ASH	0.500		0	0	0	NR	NR	0
DRYCLEANERS	0.250		0	0	NR	NR	NR	0
Financial Assurance	TP		NR	NR	NR	NR	NR	0
HWAR	TP		NR	NR	NR	NR	NR	0
IMPDMNT	0.500		0	0	0	NR	NR	0
NPDES	TP		NR	NR	NR	NR	NR	0
PIMW	0.250		0	0	NR	NR	NR	0
TIER 2	TP		NR	NR	NR	NR	NR	0
UIC	TP		NR	NR	NR	NR	NR	0
ECHO	TP		NR	NR	NR	NR	NR	0
FUELS PROGRAM	0.250		0	0	NR	NR	NR	0

EDR HIGH RISK HISTORICAL RECORDS

EDR Exclusive Records

EDR MGP	0.500		0	0	0	NR	NR	0
EDR Hist Auto	0.250		1	2	NR	NR	NR	3

MAP FINDINGS SUMMARY

Database	Search Distance (Miles)	Target Property	< 1/8	1/8 - 1/4	1/4 - 1/2	1/2 - 1	> 1	Total Plotted
EDR Hist Cleaner	0.250		0	0	NR	NR	NR	0
<u>EDR RECOVERED GOVERNMENT ARCHIVES</u>								
<i>Exclusive Recovered Govt. Archives</i>								
RGA HWS	0.500		0	0	0	NR	NR	0
RGA LF	0.500		0	0	0	NR	NR	0
RGA LUST	0.500		0	5	10	NR	NR	15
- Totals --		0	2	17	22	0	0	41

NOTES:

TP = Target Property

NR = Not Requested at this Search Distance

Sites may be listed in more than one database

MAP FINDINGS

Map ID
Direction
Distance
Distance (ft.)Site

EDR ID Number

Database(s) EPA ID Number

1
North
< 1/8
0.101 mi.
531 ft.

324 E CENTRAL BLVD
VILLA PARK, IL 60181

EDR Hist Auto 1015425823
N/A

EDR Historical Auto Stations:

Name: M & M AUTO SERVICE
Year: 1999
Address: 324 E CENTRAL BLVD

Name: M & M AUTO SERVICE
Year: 2000
Address: 324 E CENTRAL BLVD

Name: M & M AUTO SERVICE
Year: 2001
Address: 324 E CENTRAL BLVD

Name: M & M AUTO SERVICE
Year: 2002
Address: 324 E CENTRAL BLVD

Name: M & M AUTO SERVICE
Year: 2003
Address: 324 E CENTRAL BLVD

Name: M & M AUTO SERVICE
Year: 2004
Address: 324 E CENTRAL BLVD

Name: M & M AUTO SERVICE
Year: 2006
Address: 324 E CENTRAL BLVD

Name: M & M AUTO SERVICE
Year: 2007
Address: 324 E CENTRAL BLVD

Name: M & M AUTO SERVICE
Year: 2008
Address: 324 E CENTRAL BLVD

Name: M & M AUTO SERVICE
Year: 2009
Address: 324 E CENTRAL BLVD

Name: M & M AUTO SERVICE
Year: 2011
Address: 324 E CENTRAL BLVD

Name: M & M AUTO SERVICE
Year: 2012
Address: 324 E CENTRAL BLVD

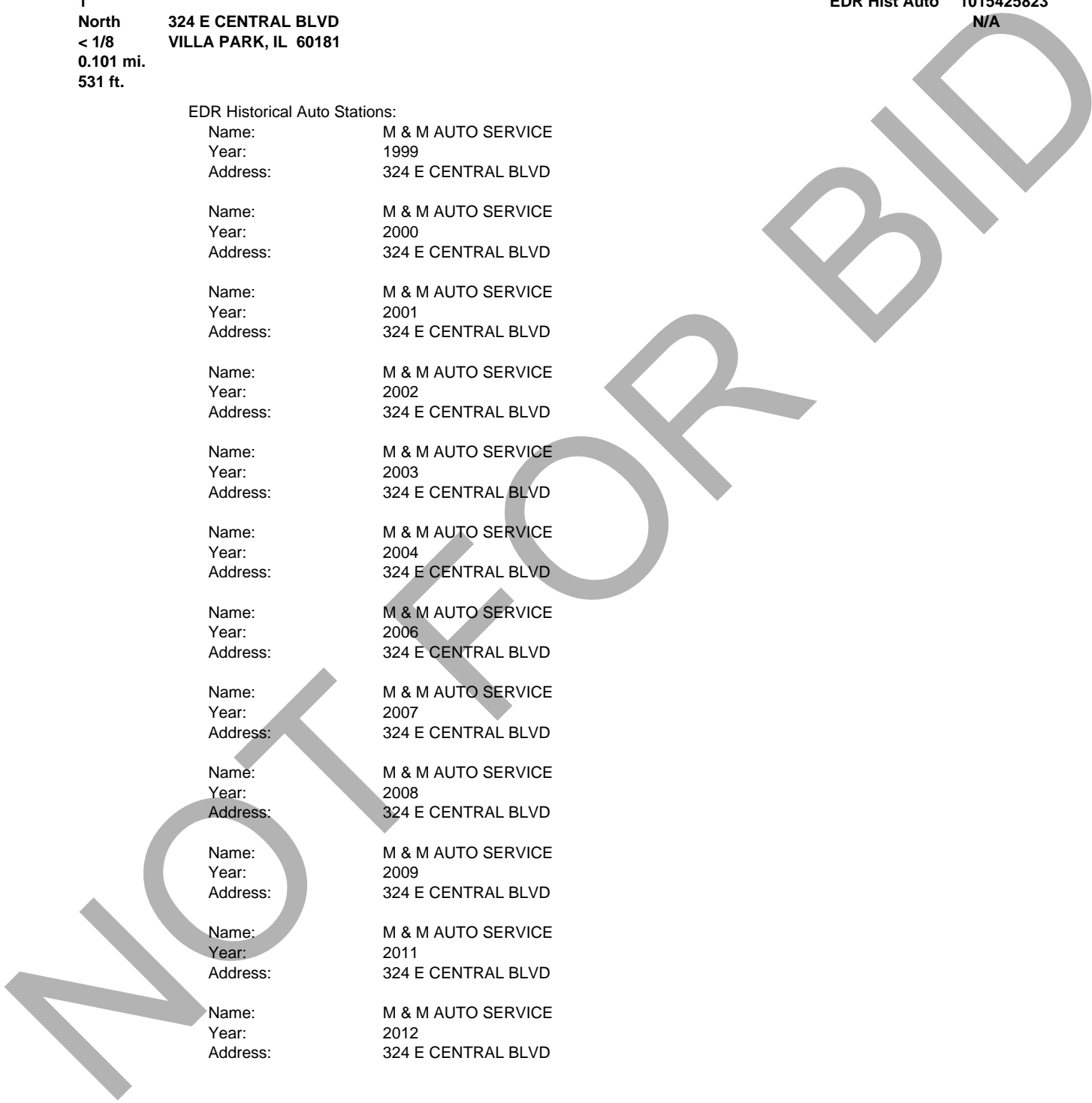

MAP FINDINGS

Map ID
 Direction
 Distance
 Distance (ft.)Site

EDR ID Number

Database(s) EPA ID Number

2
NE
 < 1/8
 0.102 mi.
 538 ft.

213 - 217 SOUTH VILLA AVE BUILDING
213 - 217 SOUTH VILLA AVE
VILLA PARK, IL 60181

UST **U003669452**
N/A

UST:

Facility ID: 2038333
 Facility Status: EXEMPT
Facility Type: COMMERCIAL / RETAIL
 Owner Id: U0028087
 Owner Name: Villa Park Trust & Savings #2077
 Owner Address: 236 W Roosevelt %ReMax Achievers
 Owner City,St,Zip: Villa Park, IL 60181

Tank Number: 1
Tank Status: Exempt from registration
 Tank Capacity: 2000
 Tank Substance: Heating Oil
 Last Used Date: 12/1/1973
 OSFM First Notify Date: Not reported
 Red Tag Issue Date: Not reported
 Install Date: Not reported
Green Tag Decal: Not reported
Green Tag Issue Date: Not reported
Green Tag Expire Date: Not reported
 Fee Due: Not reported
 Motor Fuel Permit Inspection Date: Not reported
 Motor Fuel Permit Expiration Date: Not reported
 MOTOR FUEL TYPE: Not reported
 Pending Nov: N
 IEMA: 99-1024
 Equipment Type: Not reported
 Equipment: Not reported
 Last Passing Date: Not reported
 Test Expire Date: Not reported

3
NNE
 1/8-1/4
 0.138 mi.
 727 ft.

207 S VILLA AVE
VILLA PARK, IL 60181

EDR Hist Auto **1015315311**
N/A

EDR Historical Auto Stations:

Name: MIDWEST AUTO ELECTRONICS
 Year: 2007
 Address: 207 S VILLA AVE

Name: MIDWEST AUTO ELECTRONICS
 Year: 2009
 Address: 207 S VILLA AVE

MAP FINDINGS

Map ID
 Direction
 Distance
 Distance (ft.)Site

EDR ID Number

Database(s) EPA ID Number

A4 **MAHONEY, MICHELE**
NE **213-217 SOUTH VILLA AVE.**
1/8-1/4 **VILLA PARK, IL**
0.144 mi.
762 ft. **Site 1 of 2 in cluster A**

RGA LUST **S115511979**
 N/A

RGA LUST:

2012	MAHONEY, MICHELE	213-217 SOUTH VILLA AVE.
2011	MAHONEY, MICHELE	213-217 SOUTH VILLA AVE.
2010	MAHONEY, MICHELE	213-217 SOUTH VILLA AVE.
2009	MAHONEY, MICHELE	213-217 SOUTH VILLA AVE.
2008	MAHONEY, MICHELE	213-217 SOUTH VILLA AVE.
2007	MAHONEY, MICHELE	213-217 SOUTH VILLA AVE.
2006	MAHONEY, MICHELE	213-217 SOUTH VILLA AVE.
2005	MAHONEY, MICHELE	213-217 SOUTH VILLA AVE.
2004	MAHONEY, MICHELE	213-217 SOUTH VILLA AVE.
2003	MAHONEY, MICHELE	213-217 SOUTH VILLA AVE.
2002	MAHONEY, MICHELE	213-217 SOUTH VILLA AVE.
2001	MAHONEY, MICHELE	213-217 SOUTH VILLA AVE.
2000	MAHONEY, MICHELE	213-217 SOUTH VILLA AVE.

A5 **MAHONEY, MICHELE**
NE **213-217 SOUTH VILLA AVE.**
1/8-1/4 **VILLA PARK, IL 60181**
0.144 mi.
762 ft. **Site 2 of 2 in cluster A**

LUST **S104529668**
 N/A

LUST:

Incident Num: 991024
 IL EPA Id: 0430805126
 Product: Other Petroleum
 IEMA Date: 04/26/1999
 Project Manager: Salch
 Project Manager Phone: Not reported
 Email: Not reported
 PRP Name: Michele Mahoney
 PRP Contact: Not reported
 PRP Address: P.O. Box 1283
 PRP City,St,Zip: Wayne, IL 60181
 PRP Phone: 6303779903
 Site Classification: Not reported
 Section 57.5(g) Letter: 732
 Date Section 57.5(g) Letter: Not reported
 Non LUST Determination Letter: Not reported
 20 Report Received: 05/14/1999
 45 Report Received: 08/09/1999
NFA/NFR Letter: 09/02/1999
 NFR Date Recorded: 10/12/1999

6 **ASSOCIATED TECHNICAL SVCS LTD**
North **321 E KENILWORTH AVE**
1/8-1/4 **VILLA PARK, IL 60181**
0.146 mi.
771 ft.

INST CONTROL **S118193829**
 SRP **N/A**
 BOL

IL INSTUTIONAL CONTROL:

Illinois EPA Id: 0430805186
 NFR Letter: 02/11/2016
 Date NFR Recorded: Not reported

MAP FINDINGS

Map ID
 Direction
 Distance
 Distance (ft.)Site

EDR ID Number

Database(s) EPA ID Number

ASSOCIATED TECHNICAL SVCS LTD (Continued)

S118193829

Comprehensive / Focused: Focused
 Remediation Applicant Name: Ralph Gross
 RA Company: Associated Technical Services Ltd
 RA Address: 524 West Saint Charles Road
 RA City,St,Zip: Villa Park, IL 60181
 Worker Caution: No
 Acres: 0.69
 Land Use: Industrial/Commercial
 Ground Water Use Restriction: Yes
 Highway Authority Agreement: No
 Ordinance: No
 Industrial - Commercial: Yes
 Slab on Grade: Yes
 BCT: Yes
 Building Slab: No
 Asphalt Used: No
 Concrete Used: No
 Clean Soil 3ft: No
 Clean Soil 10ft: No
 Alternate Barrier: No

SRP:

IL EPA Id: 0430805186
 US EPA Id: Not reported
 Longitude: -87.970407
 Latitude: 41.886284
 Contact Name: Ralph Gross
 Contact Address: 524 West Saint Charles Road
 Contact City,St,Zip: Villa Park, IL 60181
 Date Enrolled: 07/27/2015
 Point Of Contact: Tom Forsmark
 Consultant Company: ETS Environmental & Associates, LLC
 Consultant Address: 204 Dearborn Court
 Consultant City,St,Zip: Geneva, IL 60134
 Proj Mgr Assigned: James Baldwin
 Sec. 4 Letter Date: Not reported
 Active: No
 Remediation Applicant Co: Associated Technical Services Ltd
 Remediation Applicant Name: Ralph Gross
 Remediation Applicant Company: Associated Technical Services Ltd
 Remediation Applicant Address: 524 West Saint Charles Road
 Remediation Applicant City,St,Zip: Villa Park, IL 60181
 Illinois EPA: 0430805186
 Site Name: Associated Technical Services Ltd
 NFR Letter: 2016-02-11
 NFR Letter Date Recorded: Not reported
 Comprehensive/Focused: Focused
 Worker Caution: No
 Acres: 0.69
 Land Use: Industrial/Commercial
 Ground Water Use Restriction: Yes
 Highway Authority Agreement: No
 Ordinance: No
 Industrial - Commercial: Yes
 Slab on Grade: Yes
 BCT: Yes
 Building Slab: No

MAP FINDINGS

Map ID
 Direction
 Distance
 Distance (ft.)Site

EDR ID Number
 EPA ID Number

Database(s)

ASSOCIATED TECHNICAL SVCS LTD (Continued)

S118193829

Asphalt Used: No
 Concrete Used: No
 Clean Soil 3ft: No
 Clean Soil 10ft: No
 Alternate Barrier: No

Click here for IL SRP:

BOL:

Site Id: 170002111391
 Inv Num: 0430805186
 Interest Name: Associated Technical Svcs Ltd
 Interest Type: BOL
 Media Code: LAND

**B7
 NNW
 1/8-1/4
 0.165 mi.
 871 ft.**

**KENILWORTH PARK TOWNHOMES
 260 EAST KENILWORTH AVENUE
 VILLA PARK, IL 60181**

**LUST U004051878
 UST N/A**

Site 1 of 2 in cluster B

LUST:

Incident Num: 20060530
 IL EPA Id: 0430805168
 Product: Other Petroleum
 IEMA Date: 05/04/2006
 Project Manager: Harlow
 Project Manager Phone: Not reported
 Email: Not reported
 PRP Name: Not reported
 PRP Contact: Not reported
 PRP Address: Not reported
 PRP City,St,Zip: Not reported
 PRP Phone: Not reported
 Site Classification: Not reported
 Section 57.5(g) Letter: 734
 Date Section 57.5(g) Letter: Not reported
 Non LUST Determination Letter: Not reported
 20 Report Received: 05/19/2006
 45 Report Received: 07/11/2006
NFA/NFR Letter: 09/05/2006
 NFR Date Recorded: 10/05/2006

UST:

Facility ID: 2043211
 Facility Status: EXEMPT
Facility Type: NONE
 Owner Id: U0033356
 Owner Name: New Urban Communities
 Owner Address: 99 South Villa Avenue
 Owner City,St,Zip: Villa Park, IL 60181

Tank Number: 1
Tank Status: Exempt from registration
 Tank Capacity: 3000
 Tank Substance: Heating Oil

MAP FINDINGS

Map ID
 Direction
 Distance
 Distance (ft.)Site

EDR ID Number
 EPA ID Number

Database(s)

KENILWORTH PARK TOWNHOMES (Continued)

U004051878

Last Used Date: 12/31/1973
 OSFM First Notify Date: Not reported
 Red Tag Issue Date: Not reported
 Install Date: Not reported
Green Tag Decal: Not reported
Green Tag Issue Date: Not reported
Green Tag Expire Date: Not reported
 Fee Due: Not reported
 Motor Fuel Permit Inspection Date: Not reported
 Motor Fuel Permit Expiration Date: Not reported
 MOTOR FUEL TYPE: Not reported
 Pending Nov: N
 IEMA: 06-0530
 Equipment Type: Not reported
 Equipment: Not reported
 Last Passing Date: Not reported
 Test Expire Date: Not reported

Tank Number: 2
Tank Status: Exempt from registration
 Tank Capacity: 1000
 Tank Substance: Heating Oil
 Last Used Date: 12/31/1973
 OSFM First Notify Date: Not reported
 Red Tag Issue Date: Not reported
 Install Date: Not reported
Green Tag Decal: Not reported
Green Tag Issue Date: Not reported
Green Tag Expire Date: Not reported
 Fee Due: Not reported
 Motor Fuel Permit Inspection Date: Not reported
 Motor Fuel Permit Expiration Date: Not reported
 MOTOR FUEL TYPE: Not reported
 Pending Nov: N
 IEMA: Not reported
 Equipment Type: Not reported
 Equipment: Not reported
 Last Passing Date: Not reported
 Test Expire Date: Not reported

**B8
 NNW
 1/8-1/4
 0.165 mi.
 871 ft.**

**NEW URBAN COMMUNITIES
 260 EAST KENILWORTH AVENUE
 VILLA PARK, IL**

**RGA LUST S115514257
 N/A**

Site 2 of 2 in cluster B

RGA LUST:

2012	NEW URBAN COMMUNITIES	260 EAST KENILWORTH AVENUE
2011	NEW URBAN COMMUNITIES	260 EAST KENILWORTH AVENUE
2010	NEW URBAN COMMUNITIES	260 EAST KENILWORTH AVENUE
2009	NEW URBAN COMMUNITIES	260 EAST KENILWORTH AVENUE
2008	NEW URBAN COMMUNITIES	260 EAST KENILWORTH AVENUE
2007	NEW URBAN COMMUNITIES	260 EAST KENILWORTH AVENUE
2006	NEW URBAN COMMUNITIES	260 EAST KENILWORTH AVENUE

MAP FINDINGS

Map ID
 Direction
 Distance
 Distance (ft.)Site

EDR ID Number

Database(s) EPA ID Number

C9 LINCOLN PROPERTY CO OVALTINE
NNE ONE OVALTINE CT
1/8-1/4 VILLA PARK, IL 60181
0.198 mi.
1043 ft. Site 1 of 7 in cluster C

UST 1000292640
RCRA NonGen / NLR ILD083076612

UST:

Facility ID: 2039594
 Facility Status: CLOSED
Facility Type: NONE
 Owner Id: U0029366
 Owner Name: Lincoln Property Company
 Owner Address: 2603 West 22nd Street Suite 22
 Owner City,St,Zip: Oak Brook, IL 60523

Tank Number: 1
Tank Status: Exempt from registration
 Tank Capacity: 1100
 Tank Substance: Mineral Spirits
 Last Used Date: 1/1/1973
 OSFM First Notify Date: Not reported
 Red Tag Issue Date: Not reported
 Install Date: Not reported
Green Tag Decal: Not reported
Green Tag Issue Date: Not reported
Green Tag Expire Date: Not reported
 Fee Due: Not reported
 Motor Fuel Permit Inspection Date: Not reported
 Motor Fuel Permit Expiration Date: Not reported
 MOTOR FUEL TYPE: Not reported
 Pending Nov: N
 IEMA: 00-0540, 00-0541
 Equipment Type: Not reported
 Equipment: Not reported
 Last Passing Date: Not reported
 Test Expire Date: Not reported

Tank Number: 2
Tank Status: Exempt from registration
 Tank Capacity: 1500
 Tank Substance: Gasoline
 Last Used Date: 1/1/1973
 OSFM First Notify Date: Not reported
 Red Tag Issue Date: Not reported
 Install Date: Not reported
Green Tag Decal: Not reported
Green Tag Issue Date: Not reported
Green Tag Expire Date: Not reported
 Fee Due: Not reported
 Motor Fuel Permit Inspection Date: Not reported
 Motor Fuel Permit Expiration Date: Not reported
 MOTOR FUEL TYPE: Not reported
 Pending Nov: N
 IEMA: Not reported
 Equipment Type: Not reported
 Equipment: Not reported
 Last Passing Date: Not reported
 Test Expire Date: Not reported

MAP FINDINGS

Map ID
 Direction
 Distance
 Distance (ft.)Site

EDR ID Number

Database(s) EPA ID Number

LINCOLN PROPERTY CO OVALTINE (Continued)

1000292640

RCRA NonGen / NLR:

Date form received by agency: 04/25/2000
 Facility name: LINCOLN PROPERTY CO OVALTINE
 Facility address: ONE OVALTINE CT
 VILLA PARK, IL 60181
 EPA ID: ILD083076612
 Contact: ERIC HOLST
 Contact address: ONE OVALTINE CT
 VILLA PARK, IL 60181
 Contact country: US
 Contact telephone: (630) 530-0759
 Contact email: Not reported
 EPA Region: 05
 Classification: Non-Generator
 Description: Handler: Non-Generators do not presently generate hazardous waste

Owner/Operator Summary:

Owner/operator name: NAME NOT REPORTED
 Owner/operator address: ADDRESS NOT REPORTED
 CITY NOT REPORTED, AK 99998
 Owner/operator country: Not reported
 Owner/operator telephone: (312) 555-1212
 Legal status: Private
 Owner/Operator Type: Operator
 Owner/Op start date: Not reported
 Owner/Op end date: Not reported

Owner/operator name: LINCOLN PROPERTY CO
 Owner/operator address: 2603 W 22ND ST SUITE 22
 OAK BROOK, IL 60521
 Owner/operator country: Not reported
 Owner/operator telephone: (630) 572-6663
 Legal status: Private
 Owner/Operator Type: Owner
 Owner/Op start date: Not reported
 Owner/Op end date: Not reported

Handler Activities Summary:

U.S. importer of hazardous waste: No
 Mixed waste (haz. and radioactive): No
 Recycler of hazardous waste: No
 Transporter of hazardous waste: No
 Treater, storer or disposer of HW: No
 Underground injection activity: No
 On-site burner exemption: No
 Furnace exemption: No
 Used oil fuel burner: No
 Used oil processor: No
 User oil refiner: No
 Used oil fuel marketer to burner: No
 Used oil Specification marketer: No
 Used oil transfer facility: No
 Used oil transporter: No

. Waste code: D001
 . Waste name: IGNITABLE WASTE

MAP FINDINGS

Map ID
 Direction
 Distance
 Distance (ft.)Site

EDR ID Number

Database(s) EPA ID Number

LINCOLN PROPERTY CO OVALTINE (Continued)

1000292640

- . Waste code: D002
- . Waste name: CORROSIVE WASTE

- . Waste code: D003
- . Waste name: REACTIVE WASTE

- . Waste code: F003
- . Waste name: THE FOLLOWING SPENT NONHALOGENATED SOLVENTS: XYLENE, ACETONE, ETHYL ACETATE, ETHYL BENZENE, ETHYL ETHER, METHYL ISOBUTYL KETONE, N-BUTYL ALCOHOL, CYCLOHEXANONE, AND METHANOL; ALL SPENT SOLVENT MIXTURES/BLENDS CONTAINING, BEFORE USE, ONLY THE ABOVE SPENT NONHALOGENATED SOLVENTS; AND ALL SPENT SOLVENT MIXTURES/BLENDS CONTAINING, BEFORE USE, ONE OR MORE OF THE ABOVE NONHALOGENATED SOLVENTS, AND A TOTAL OF TEN PERCENT OR MORE (BY VOLUME) OF ONE OR MORE OF THOSE SOLVENTS LISTED IN F001, F002, F004, AND F005; AND STILL BOTTOMS FROM THE RECOVERY OF THESE SPENT SOLVENTS AND SPENT SOLVENT MIXTURES.

- . Waste code: F005
- . Waste name: THE FOLLOWING SPENT NONHALOGENATED SOLVENTS: TOLUENE, METHYL ETHYL KETONE, CARBON DISULFIDE, ISOBUTANOL, PYRIDINE, BENZENE, 2-ETHOXYETHANOL, AND 2-NITROPROPANE; ALL SPENT SOLVENT MIXTURES/BLENDS CONTAINING, BEFORE USE, A TOTAL OF TEN PERCENT OR MORE (BY VOLUME) OF ONE OR MORE OF THE ABOVE NONHALOGENATED SOLVENTS OR THOSE SOLVENTS LISTED IN F001, F002, OR F004; AND STILL BOTTOMS FROM THE RECOVERY OF THESE SPENT SOLVENTS AND SPENT SOLVENT MIXTURES.

- . Waste code: U242
- . Waste name: U242

- Violation Status: No violations found

C10 LINCOLN PROPERTY CO.
NNE 1 OVALTINE CT.
 1/8-1/4 VILLA PARK, IL 60181
 0.198 mi.
 1043 ft. Site 2 of 7 in cluster C

LUST S104530570
BOL N/A

LUST:
 Incident Num: 20000540
 IL EPA Id: 0430805008
 Product: Other Petroleum
 IEMA Date: 03/28/2000
 Project Manager: Bloome
 Project Manager Phone: Not reported
 Email: Not reported
 PRP Name: Lincoln Property Co.
 PRP Contact: Eric Holst
 PRP Address: 1 Ovaltine Ct.
 PRP City,St,Zip: Villa Park, IL 60181
 PRP Phone: 6305300759
 Site Classification: Not reported
 Section 57.5(g) Letter: 732
 Date Section 57.5(g) Letter: Not reported
 Non LUST Determination Letter: Not reported
 20 Report Received: 04/24/2000
 45 Report Received: 05/22/2000
NFA/NFR Letter: 08/24/2000
 NFR Date Recorded: 09/18/2000

MAP FINDINGS

Map ID
 Direction
 Distance
 Distance (ft.)Site

EDR ID Number

Database(s) EPA ID Number

LINCOLN PROPERTY CO. (Continued)

S104530570

Incident Num: 20000541
 IL EPA Id: 0430805008
 Product: Gasoline
 IEMA Date: 03/28/2000
 Project Manager: Bloome
 Project Manager Phone: Not reported
 Email: Not reported
 PRP Name: Lincoln Properties Co.
 PRP Contact: Eric Holst
 PRP Address: 1 Ovaltine Ct.
 PRP City,St,Zip: Villa Park, IL 60181
 PRP Phone: 6305300759
 Site Classification: Not reported
 Section 57.5(g) Letter: 732
 Date Section 57.5(g) Letter: Not reported
 Non LUST Determination Letter: Not reported
 20 Report Received: 04/24/2000
 45 Report Received: 05/22/2000
NFA/NFR Letter: 08/24/2000
 NFR Date Recorded: 09/18/2000

BOL:

Site Id: 170000174745
 Inv Num: 0430805008
 Interest Name: Lincoln Properties Co
 Interest Type: BOL
 Media Code: LAND

**C11
 NNE
 1/8-1/4
 0.198 mi.
 1043 ft.**

**LINCOLN PROPERTY CO.
 1 OVALTINE CT.
 VILLA PARK, IL**

**RGA LUST S115511534
 N/A**

Site 3 of 7 in cluster C

RGA LUST:

2012	LINCOLN PROPERTY CO.	1 OVALTINE CT.
2011	LINCOLN PROPERTY CO.	1 OVALTINE CT.
2010	LINCOLN PROPERTY CO.	1 OVALTINE CT.
2009	LINCOLN PROPERTY CO.	1 OVALTINE CT.
2008	LINCOLN PROPERTY CO.	1 OVALTINE CT.
2007	LINCOLN PROPERTY CO.	1 OVALTINE CT.
2006	LINCOLN PROPERTY CO.	1 OVALTINE CT.
2005	LINCOLN PROPERTY CO.	1 OVALTINE CT.
2004	LINCOLN PROPERTY CO.	1 OVALTINE CT.
2003	LINCOLN PROPERTY CO.	1 OVALTINE CT.
2002	LINCOLN PROPERTY CO.	1 OVALTINE CT.
2001	LINCOLN PROPERTY CO.	1 OVALTINE CT.
2000	LINCOLN PROPERTY CO.	1 OVALTINE CT.

MAP FINDINGS

Map ID
 Direction
 Distance
 Distance (ft.)Site

EDR ID Number

Database(s) EPA ID Number

C12 **LINCOLN PROPERTIES CO.**
NNE **1 OVALTINE CT.**
1/8-1/4 **VILLA PARK, IL**
0.198 mi.
1043 ft. **Site 4 of 7 in cluster C**

RGA LUST **S115511533**
N/A

RGA LUST:

2012	LINCOLN PROPERTIES CO.	1 OVALTINE CT.
2011	LINCOLN PROPERTIES CO.	1 OVALTINE CT.
2010	LINCOLN PROPERTIES CO.	1 OVALTINE CT.
2009	LINCOLN PROPERTIES CO.	1 OVALTINE CT.
2008	LINCOLN PROPERTIES CO.	1 OVALTINE CT.
2007	LINCOLN PROPERTIES CO.	1 OVALTINE CT.
2006	LINCOLN PROPERTIES CO.	1 OVALTINE CT.
2005	LINCOLN PROPERTIES CO.	1 OVALTINE CT.
2004	LINCOLN PROPERTIES CO.	1 OVALTINE CT.
2003	LINCOLN PROPERTIES CO.	1 OVALTINE CT.
2002	LINCOLN PROPERTIES CO.	1 OVALTINE CT.
2001	LINCOLN PROPERTIES CO.	1 OVALTINE CT.
2000	LINCOLN PROPERTIES CO.	1 OVALTINE CT.

C13 **VILLA PARK MATERIAL CO**
NNE **110 S VILLA AVE**
1/8-1/4 **VILLA PARK, IL 60181**
0.219 mi.
1154 ft. **Site 5 of 7 in cluster C**

UST **U001135452**
N/A

UST:

Facility ID:	2019073
Facility Status:	EXEMPT
Facility Type:	PETROLEUM DISTRIBUTOR
Owner Id:	U0015733
Owner Name:	Villa Park Material Co
Owner Address:	110 S Villa Ave
Owner City,St,Zip:	Villa Park, IL 60181
Tank Number:	1
Tank Status:	Exempt from registration
Tank Capacity:	1000
Tank Substance:	Not reported
Last Used Date:	5/1/1982
OSFM First Notify Date:	4/2/1986
Red Tag Issue Date:	Not reported
Install Date:	1/1/1962
Green Tag Decal:	Not reported
Green Tag Issue Date:	Not reported
Green Tag Expire Date:	Not reported
Fee Due:	Not reported
Motor Fuel Permit Inspection Date:	Not reported
Motor Fuel Permit Expiration Date:	Not reported
MOTOR FUEL TYPE:	Not reported
Pending Nov:	N
IEMA:	Not reported
Equipment Type:	Not reported
Equipment:	Not reported
Last Passing Date:	Not reported
Test Expire Date:	Not reported

MAP FINDINGS

Map ID Direction Distance Distance (ft.) Site Database(s) EPA ID Number EDR ID Number

C14 RUGAARD, PRESTON LUST S104524477
NNE 110 SOUTH VILLA AVE. N/A
 1/8-1/4 VILLA PARK, IL 60181
 0.219 mi.
 1154 ft. Site 6 of 7 in cluster C

LUST:
 Incident Num: 922860
 IL EPA Id: 0430805094
 Product: Non-Petroleum Product
 IEMA Date: 10/12/1992
 Project Manager: NOT ASSIGNED
 Project Manager Phone: Not reported
 Email: Not reported
 PRP Name: Preston Rugaard
 PRP Contact: Not reported
 PRP Address: 54 East St. Charles Rd.
 PRP City, St, Zip: Villa Park, IL 60181
 PRP Phone: Not reported
 Site Classification: Not reported
 Section 57.5(g) Letter: 731
 Date Section 57.5(g) Letter: Not reported
 Non LUST Determination Letter: Not reported
 20 Report Received: 03/19/1993
 45 Report Received: Not reported
NFA/NFR Letter: Not reported
 NFR Date Recorded: Not reported

C15 RUGAARD, PRESTON RGA LUST S115517384
NNE 110 SOUTH VILLA AVE. N/A
 1/8-1/4 VILLA PARK, IL
 0.219 mi.
 1154 ft. Site 7 of 7 in cluster C

RGA LUST:

2012	RUGAARD, PRESTON	110 SOUTH VILLA AVE.
2011	RUGAARD, PRESTON	110 SOUTH VILLA AVE.
2010	RUGAARD, PRESTON	110 SOUTH VILLA AVE.
2009	RUGAARD, PRESTON	110 SOUTH VILLA AVE.
2008	RUGAARD, PRESTON	110 SOUTH VILLA AVE.
2007	RUGAARD, PRESTON	110 SOUTH VILLA AVE.
2006	RUGAARD, PRESTON	110 SOUTH VILLA AVE.
2005	RUGAARD, PRESTON	110 SOUTH VILLA AVE.
2004	RUGAARD, PRESTON	110 SOUTH VILLA AVE.
2003	RUGAARD, PRESTON	110 SOUTH VILLA AVE.
2002	RUGAARD, PRESTON	110 SOUTH VILLA AVE.
2001	RUGAARD, PRESTON	110 SOUTH VILLA AVE.
2000	RUGAARD, PRESTON	110 SOUTH VILLA AVE.

D16 EDR Hist Auto 1015119406
NNE 100 S VILLA AVE N/A
 1/8-1/4 VILLA PARK, IL 60181
 0.237 mi.
 1251 ft. Site 1 of 2 in cluster D

EDR Historical Auto Stations:
 Name: VILLA PARK BODY SHOP INCORPORATED
 Year: 1999
 Address: 100 S VILLA AVE

MAP FINDINGS

Map ID
 Direction
 Distance
 Distance (ft.) Site

EDR ID Number

Database(s) EPA ID Number

(Continued)

1015119406

Name: VILLA PARK BODY SHOP INCORPORATED
 Year: 2000
 Address: 100 S VILLA AVE

Name: VILLA PARK AUTO BODY INC
 Year: 2001
 Address: 100 S VILLA AVE

Name: VILLA PARK AUTO BODY INC
 Year: 2002
 Address: 100 S VILLA AVE

Name: VILLA PARK AUTO BODY INC
 Year: 2004
 Address: 100 S VILLA AVE

Name: VILLA PARK AUTO BODY INC
 Year: 2006
 Address: 100 S VILLA AVE

Name: VILLA PARK AUTO BODY INC
 Year: 2007
 Address: 100 S VILLA AVE

Name: VILLA PARK AUTO BODY
 Year: 2008
 Address: 100 S VILLA AVE

Name: VILLA PARK AUTO BODY INC
 Year: 2009
 Address: 100 S VILLA AVE

Name: VILLA PARK BODY SHOP INC
 Year: 2010
 Address: 100 S VILLA AVE

Name: VILLA PARK BODY SHOP INC
 Year: 2011
 Address: 100 S VILLA AVE

Name: VILLA PARK BODY SHOP INC
 Year: 2012
 Address: 100 S VILLA AVE

D17 VILLA PARK BODY SHOP INC
 NNE 100 S VILLA AVE
 1/8-1/4 VILLA PARK, IL 60181
 0.237 mi.
 1251 ft. Site 2 of 2 in cluster D

RCRA-SQG 1000275673
 FINDS ILD065816480
 ECHO

RCRA-SQG:
 Date form received by agency: 06/10/1988
 Facility name: VILLA PARK BODY SHOP INC
 Facility address: 100 S VILLA AVE
 VILLA PARK, IL 60181
 EPA ID: ILD065816480
 Contact: GEORGE RENTZ
 Contact address: 100 S VILLA AVE

MAP FINDINGS

Map ID
 Direction
 Distance
 Distance (ft.)Site

EDR ID Number
 EPA ID Number

Database(s)

VILLA PARK BODY SHOP INC (Continued)

1000275673

VILLA PARK, IL 60181
 Contact country: US
 Contact telephone: (312) 530-2324
 Contact email: Not reported
 EPA Region: 05
 Classification: Small Small Quantity Generator
 Description: Handler: generates more than 100 and less than 1000 kg of hazardous waste during any calendar month and accumulates less than 6000 kg of hazardous waste at any time; or generates 100 kg or less of hazardous waste during any calendar month, and accumulates more than 1000 kg of hazardous waste at any time

Owner/Operator Summary:

Owner/operator name: RENTZ GEORGE AND RICHARD
 Owner/operator address: ADDRESS NOT REPORTED
 CITY NOT REPORTED, AK 99998
 Owner/operator country: Not reported
 Owner/operator telephone: (312) 555-1212
 Legal status: Private
 Owner/Operator Type: Owner
 Owner/Op start date: Not reported
 Owner/Op end date: Not reported

Owner/operator name: NAME NOT REPORTED
 Owner/operator address: ADDRESS NOT REPORTED
 CITY NOT REPORTED, AK 99998
 Owner/operator country: Not reported
 Owner/operator telephone: (312) 555-1212
 Legal status: Private
 Owner/Operator Type: Operator
 Owner/Op start date: Not reported
 Owner/Op end date: Not reported

Handler Activities Summary:

U.S. importer of hazardous waste: No
 Mixed waste (haz. and radioactive): No
 Recycler of hazardous waste: No
 Transporter of hazardous waste: No
 Treater, storer or disposer of HW: No
 Underground injection activity: No
 On-site burner exemption: No
 Furnace exemption: No
 Used oil fuel burner: No
 Used oil processor: No
 User oil refiner: No
 Used oil fuel marketer to burner: No
 Used oil Specification marketer: No
 Used oil transfer facility: No
 Used oil transporter: No

. Waste code: D000
 . Waste name: Not Defined
 . Waste code: D001
 . Waste name: IGNITABLE WASTE

MAP FINDINGS

Map ID
 Direction
 Distance
 Distance (ft.)Site

EDR ID Number

Database(s) EPA ID Number

VILLA PARK BODY SHOP INC (Continued)

1000275673

. Waste code: F003
 . Waste name: THE FOLLOWING SPENT NONHALOGENATED SOLVENTS: XYLENE, ACETONE, ETHYL ACETATE, ETHYL BENZENE, ETHYL ETHER, METHYL ISOBUTYL KETONE, N-BUTYL ALCOHOL, CYCLOHEXANONE, AND METHANOL; ALL SPENT SOLVENT MIXTURES/BLENDS CONTAINING, BEFORE USE, ONLY THE ABOVE SPENT NONHALOGENATED SOLVENTS; AND ALL SPENT SOLVENT MIXTURES/BLENDS CONTAINING, BEFORE USE, ONE OR MORE OF THE ABOVE NONHALOGENATED SOLVENTS, AND A TOTAL OF TEN PERCENT OR MORE (BY VOLUME) OF ONE OR MORE OF THOSE SOLVENTS LISTED IN F001, F002, F004, AND F005; AND STILL BOTTOMS FROM THE RECOVERY OF THESE SPENT SOLVENTS AND SPENT SOLVENT MIXTURES.

. Waste code: F005
 . Waste name: THE FOLLOWING SPENT NONHALOGENATED SOLVENTS: TOLUENE, METHYL ETHYL KETONE, CARBON DISULFIDE, ISOBUTANOL, PYRIDINE, BENZENE, 2-ETHOXYETHANOL, AND 2-NITROPROPANE; ALL SPENT SOLVENT MIXTURES/BLENDS CONTAINING, BEFORE USE, A TOTAL OF TEN PERCENT OR MORE (BY VOLUME) OF ONE OR MORE OF THE ABOVE NONHALOGENATED SOLVENTS OR THOSE SOLVENTS LISTED IN F001, F002, OR F004; AND STILL BOTTOMS FROM THE RECOVERY OF THESE SPENT SOLVENTS AND SPENT SOLVENT MIXTURES.

Violation Status: No violations found

FINDS:

Registry ID: 110005835917

Environmental Interest/Information System

ACES (Illinois - Agency Compliance And Enforcement System) is the Illinois EPA Project to facilitate the permitting operations

RCRAInfo is a national information system that supports the Resource Conservation and Recovery Act (RCRA) program through the tracking of events and activities related to facilities that generate, transport, and treat, store, or dispose of hazardous waste. RCRAInfo allows RCRA program staff to track the notification, permit, compliance, and corrective action activities required under RCRA.

ECHO:

Envid: 1000275673
 Registry ID: 110005835917
 DFR URL: http://echo.epa.gov/detailed_facility_report?fid=110005835917

E18 SHELL OIL CO.
NNE 401 EAST ST. CHARLES RD.
1/4-1/2 VILLA PARK, IL
0.371 mi.
1961 ft. Site 1 of 3 in cluster E

RGA LUST S115518312
N/A

RGA LUST:

2012	SHELL OIL CO.	401 EAST ST. CHARLES RD.
2012	SHELL OIL CO.	401 EAST ST. CHARLES RD.
2011	SHELL OIL CO.	401 EAST ST. CHARLES RD.
2011	SHELL OIL CO.	401 EAST ST. CHARLES RD.
2010	SHELL OIL CO.	401 EAST ST. CHARLES RD.
2010	SHELL OIL CO.	401 EAST ST. CHARLES RD.
2009	SHELL OIL CO.	401 EAST ST. CHARLES RD.

MAP FINDINGS

Map ID
 Direction
 Distance
 Distance (ft.)Site

EDR ID Number

Database(s) EPA ID Number

SHELL OIL CO. (Continued)

S115518312

2009	SHELL OIL CO.	401 EAST ST. CHARLES RD.
2008	SHELL OIL CO.	401 EAST ST. CHARLES RD.
2008	SHELL OIL CO.	401 EAST ST. CHARLES RD.
2007	SHELL OIL CO.	401 EAST ST. CHARLES RD.
2007	SHELL OIL CO.	401 EAST ST. CHARLES RD.
2006	SHELL OIL CO.	401 EAST ST. CHARLES RD.
2006	SHELL OIL CO.	401 EAST ST. CHARLES RD.
2005	SHELL OIL CO.	401 EAST ST. CHARLES RD.
2005	SHELL OIL CO.	401 EAST ST. CHARLES RD.
2004	SHELL OIL CO.	401 EAST ST. CHARLES RD.
2004	SHELL OIL CO.	401 EAST ST. CHARLES RD.
2003	SHELL OIL CO.	401 EAST ST. CHARLES RD.
2003	SHELL OIL CO.	401 EAST ST. CHARLES RD.
2002	SHELL OIL CO.	401 EAST ST. CHARLES RD.
2002	SHELL OIL CO.	401 EAST ST. CHARLES RD.
2001	SHELL OIL CO.	401 EAST ST. CHARLES RD.
2001	SHELL OIL CO.	401 EAST ST. CHARLES RD.
2000	SHELL OIL CO.	401 EAST ST. CHARLES RD.
2000	SHELL OIL CO.	401 EAST ST. CHARLES RD.

E19
NNE
 1/4-1/2
 0.371 mi.
 1961 ft.

SHELL OIL CO.
401 EAST ST. CHARLES RD.
VILLA PARK, IL 60181

LUST S104521508
N/A

Site 2 of 3 in cluster E

LUST:

Incident Num:	970076
IL EPA Id:	0430805060
Product:	Gasoline
IEMA Date:	01/14/1997
Project Manager:	Urish
Project Manager Phone:	(217) 524-5596
Email:	Matt.Urish@illinois.gov
PRP Name:	Equilon Enterprises LLC
PRP Contact:	Lisa Schoedel
PRP Address:	603 Diehl Rd., Suite 103
PRP City,St,Zip:	Naperville, IL 60563
PRP Phone:	6302764206
Site Classification:	HIGH
Section 57.5(g) Letter:	732
Date Section 57.5(g) Letter:	Not reported
Non LUST Determination Letter:	Not reported
20 Report Received:	03/25/1997
45 Report Received:	03/25/1997
NFA/NFR Letter:	04/20/2001
NFR Date Recorded:	05/11/2001

Incident Num:	970855
IL EPA Id:	0430805060
Product:	Used Oil
IEMA Date:	05/15/1997
Project Manager:	Urish
Project Manager Phone:	(217) 524-5596
Email:	Matt.Urish@illinois.gov
PRP Name:	Equilon Enterprises LLC
PRP Contact:	Lisa Schoedel
PRP Address:	603 Diehl Rd., Suite 103
PRP City,St,Zip:	Naperville, IL 60563

MAP FINDINGS

Map ID
 Direction
 Distance
 Distance (ft.)Site

EDR ID Number

Database(s) EPA ID Number

SHELL OIL CO. (Continued)

S104521508

PRP Phone: 6302764206
 Site Classification: HIGH
 Section 57.5(g) Letter: 732
 Date Section 57.5(g) Letter: Not reported
 Non LUST Determination Letter: Not reported
 20 Report Received: 08/28/1997
 45 Report Received: 08/28/1997
NFA/NFR Letter: 04/20/2001
 NFR Date Recorded: 05/11/2001

Incident Num: 20081051
 IL EPA Id: 0430805060
 Product: Gasoline
 IEMA Date: 07/15/2008
 Project Manager: Urish
 Project Manager Phone: (217) 524-5596
 Email: Matt.Urish@illinois.gov
 PRP Name: Not reported
 PRP Contact: Not reported
 PRP Address: Not reported
 PRP City,St,Zip: Not reported
 PRP Phone: Not reported
 Site Classification: Not reported
 Section 57.5(g) Letter: 734
 Date Section 57.5(g) Letter: Not reported
 Non LUST Determination Letter: 2009-01-12
 20 Report Received: 08/11/2008
 45 Report Received: 08/29/2008
NFA/NFR Letter: Not reported
 NFR Date Recorded: Not reported

E20
NNE
 1/4-1/2
 0.371 mi.
 1961 ft.

SHELL OIL PRODUCTS US
401 EAST ST. CHARLES ROAD
VILLA PARK, IL

RGA LUST S115518600
N/A

Site 3 of 3 in cluster E

RGA LUST:

2012	SHELL OIL PRODUCTS US	401 EAST ST. CHARLES ROAD
2011	SHELL OIL PRODUCTS US	401 EAST ST. CHARLES ROAD
2010	SHELL OIL PRODUCTS US	401 EAST ST. CHARLES ROAD
2009	SHELL OIL PRODUCTS US	401 EAST ST. CHARLES ROAD
2008	SHELL OIL PRODUCTS US	401 EAST ST. CHARLES ROAD

F21
West
 1/4-1/2
 0.374 mi.
 1973 ft.

ST. ALEXANDER'S CHURCH
300 SOUTH CORNELL AVENUE
VILLA PARK, IL 60181

LUST S108480381
N/A

Site 1 of 2 in cluster F

LUST:

Incident Num: 20070157
 IL EPA Id: 0430805171
 Product: Other Petroleum
 IEMA Date: 02/15/2007
 Project Manager: Friedel
 Project Manager Phone: (217) 785-5736

MAP FINDINGS

Map ID
 Direction
 Distance
 Distance (ft.)Site

EDR ID Number
 EPA ID Number

Database(s)

ST. ALEXANDER'S CHURCH (Continued)

S108480381

Email: Melinda.Friedel@illinois.gov
 PRP Name: Not reported
 PRP Contact: Not reported
 PRP Address: Not reported
 PRP City,St,Zip: Not reported
 PRP Phone: Not reported
 Site Classification: Not reported
 Section 57.5(g) Letter: 734
 Date Section 57.5(g) Letter: Not reported
 Non LUST Determination Letter: Not reported
 20 Report Received: 03/12/2007
 45 Report Received: 04/02/2007
NFA/NFR Letter: 06/13/2007
 NFR Date Recorded: 08/23/2007

F22
 West
 1/4-1/2
 0.374 mi.
 1973 ft.

ST. ALEXANDER'S CHURCH
300 SOUTH CORNELL AVENUE
VILLA PARK, IL

RGA LUST S115519607
N/A

Site 2 of 2 in cluster F

RGA LUST:

2012	ST. ALEXANDER'S CHURCH	300 SOUTH CORNELL AVENUE
2011	ST. ALEXANDER'S CHURCH	300 SOUTH CORNELL AVENUE
2010	ST. ALEXANDER'S CHURCH	300 SOUTH CORNELL AVENUE
2009	ST. ALEXANDER'S CHURCH	300 SOUTH CORNELL AVENUE
2008	ST. ALEXANDER'S CHURCH	300 SOUTH CORNELL AVENUE
2007	ST. ALEXANDER'S CHURCH	300 SOUTH CORNELL AVENUE

G23
 NNW
 1/4-1/2
 0.377 mi.
 1993 ft.

TIRE CENTERS, INC.
299 EAST ST. CHARLES RD.
VILLA PARK, IL

RGA LUST S115520699
N/A

Site 1 of 2 in cluster G

RGA LUST:

2012	TIRE CENTERS, INC.	299 EAST ST. CHARLES RD.
2011	TIRE CENTERS, INC.	299 EAST ST. CHARLES RD.
2010	TIRE CENTERS, INC.	299 EAST ST. CHARLES RD.
2009	TIRE CENTERS, INC.	299 EAST ST. CHARLES RD.
2008	TIRE CENTERS, INC.	299 EAST ST. CHARLES RD.
2007	TIRE CENTERS, INC.	299 EAST ST. CHARLES RD.
2006	TIRE CENTERS, INC.	299 EAST ST. CHARLES RD.
2005	TIRE CENTERS, INC.	299 EAST ST. CHARLES RD.
2004	TIRE CENTERS, INC.	299 EAST ST. CHARLES RD.
2003	TIRE CENTERS, INC.	299 EAST ST. CHARLES RD.
2002	TIRE CENTERS, INC.	299 EAST ST. CHARLES RD.
2001	TIRE CENTERS, INC.	299 EAST ST. CHARLES RD.
2000	TIRE CENTERS, INC.	299 EAST ST. CHARLES RD.

MAP FINDINGS

Map ID
 Direction
 Distance
 Distance (ft.)Site

EDR ID Number

Database(s) EPA ID Number

G24 **TIRE CENTERS, INC.**
NNW **299 EAST ST. CHARLES RD.**
1/4-1/2 **VILLA PARK, IL 60181**
0.377 mi.
1993 ft. **Site 2 of 2 in cluster G**

LUST **S104529213**
N/A

LUST:

Incident Num: 982780
 IL EPA Id: 0430805107
 Product: Used Oil
 IEMA Date: 11/09/1998
 Project Manager: Wallace
 Project Manager Phone: Not reported
 Email: Not reported
 PRP Name: Tire Centers, Inc.
 PRP Contact: Scott Lippoldt
 PRP Address: 299 East St. Charles Rd.
 PRP City,St,Zip: Villa Park, IL 60181
 PRP Phone: 6308323160
 Site Classification: Not reported
 Section 57.5(g) Letter: 732
 Date Section 57.5(g) Letter: Not reported
 Non LUST Determination Letter: Not reported
 20 Report Received: 11/23/1998
 45 Report Received: 01/11/1999
NFA/NFR Letter: 04/05/1999
 NFR Date Recorded: 04/26/1999

H25 **OAKFIELD FORD**
NNE **443 EAST ST. CHARLES RD.**
1/4-1/2 **VILLA PARK, IL**
0.404 mi.
2131 ft. **Site 1 of 2 in cluster H**

RGA LUST **S115514793**
N/A

RGA LUST:

2012	OAKFIELD FORD	443 EAST ST. CHARLES RD.
2011	OAKFIELD FORD	443 EAST ST. CHARLES RD.
2010	OAKFIELD FORD	443 EAST ST. CHARLES RD.
2009	OAKFIELD FORD	443 EAST ST. CHARLES RD.
2008	OAKFIELD FORD	443 EAST ST. CHARLES RD.
2007	OAKFIELD FORD	443 EAST ST. CHARLES RD.
2006	OAKFIELD FORD	443 EAST ST. CHARLES RD.
2005	OAKFIELD FORD	443 EAST ST. CHARLES RD.
2004	OAKFIELD FORD	443 EAST ST. CHARLES RD.
2003	OAKFIELD FORD	443 EAST ST. CHARLES RD.
2002	OAKFIELD FORD	443 EAST ST. CHARLES RD.
2001	OAKFIELD FORD	443 EAST ST. CHARLES RD.
2000	OAKFIELD FORD	443 EAST ST. CHARLES RD.

H26 **OAKFIELD FORD**
NNE **443 E ST CHARLES RD**
1/4-1/2 **VILLA PARK, IL 60181**
0.404 mi.
2131 ft. **Site 2 of 2 in cluster H**

RCRA-SQG **1000612027**
LUST **ILD984822452**
FINDS
ECHO

RCRA-SQG:

Date form received by agency: 04/25/1991
 Facility name: OAKFIELD FORD
 Facility address: 443 E ST CHARLES RD

MAP FINDINGS

Map ID
 Direction
 Distance
 Distance (ft.)Site

EDR ID Number

Database(s) EPA ID Number

OAKFIELD FORD (Continued)

1000612027

EPA ID: VILLA PARK, IL 60181
 ILD984822452
 Contact: MICHAEL MOESE
 Contact address: 443 E ST CHARLES RD
 VILLA PARK, IL 60181
 Contact country: US
 Contact telephone: (708) 534-7600
 Contact email: Not reported
 EPA Region: 05
 Classification: Small Small Quantity Generator
 Description: Handler: generates more than 100 and less than 1000 kg of hazardous waste during any calendar month and accumulates less than 6000 kg of hazardous waste at any time; or generates 100 kg or less of hazardous waste during any calendar month, and accumulates more than 1000 kg of hazardous waste at any time

Owner/Operator Summary:

Owner/operator name: OAKFORD FORD CO
 Owner/operator address: Not reported
 Not reported
 Owner/operator country: Not reported
 Owner/operator telephone: Not reported
 Legal status: Private
 Owner/Operator Type: Owner
 Owner/Op start date: Not reported
 Owner/Op end date: Not reported

Handler Activities Summary:

U.S. importer of hazardous waste: No
 Mixed waste (haz. and radioactive): No
 Recycler of hazardous waste: No
 Transporter of hazardous waste: No
 Treater, storer or disposer of HW: No
 Underground injection activity: No
 On-site burner exemption: No
 Furnace exemption: No
 Used oil fuel burner: No
 Used oil processor: No
 User oil refiner: No
 Used oil fuel marketer to burner: No
 Used oil Specification marketer: No
 Used oil transfer facility: No
 Used oil transporter: No

Waste code: D001
 Waste name: IGNITABLE WASTE

Waste code: D008
 Waste name: LEAD

Violation Status: No violations found

LUST:

Incident Num: 981438
 IL EPA Id: 0430805058
 Product: Gasoline, Used Oil
 IEMA Date: 06/15/1998

MAP FINDINGS

Map ID
 Direction
 Distance
 Distance (ft.)Site

EDR ID Number
 EPA ID Number

Database(s)

OAKFIELD FORD (Continued)

1000612027

Project Manager: Davis
 Project Manager Phone: (217) 785-7492
 Email: Valerie.A.Davis@illinois.gov
 PRP Name: Oakfield Ford
 PRP Contact: Jack Cronan
 PRP Address: 443 East St. Charles Rd.
 PRP City,St,Zip: Villa Park, IL 60181
 PRP Phone: 6308347600
 Site Classification: Not reported
 Section 57.5(g) Letter: 732
 Date Section 57.5(g) Letter: Not reported
 Non LUST Determination Letter: Not reported
 20 Report Received: 07/01/1998
 45 Report Received: 09/04/1998
NFA/NFR Letter: 09/29/1998
 NFR Date Recorded: 10/30/1998

FINDS:

Registry ID: 110005888762

Environmental Interest/Information System

ACES (Illinois - Agency Compliance And Enforcement System) is the Illinois EPA Project to facilitate the permitting operations

RCRAInfo is a national information system that supports the Resource Conservation and Recovery Act (RCRA) program through the tracking of events and activities related to facilities that generate, transport, and treat, store, or dispose of hazardous waste. RCRAInfo allows RCRA program staff to track the notification, permit, compliance, and corrective action activities required under RCRA.

ECHO:

Envid: 1000612027
 Registry ID: 110005888762
 DFR URL: http://echo.epa.gov/detailed_facility_report?fid=110005888762

27
 NNW
 1/4-1/2
 0.414 mi.
 2188 ft.

HAFER CLEANERS
159 EAST ST CHARLES
VILLA PARK, IL 60181

ENG CONTROLS S111826400
INST CONTROL N/A
SRP
DRYCLEANERS

ENGINEERING CONTROLS:

Illinois Epa Id: 0430805027
 NFR Letter: 06/28/2013
 Date NFR Recorded: 07/24/2013
 Comprehensive / Focused: Focused
 Remediation Applicant Name: John Babb
 RA Company: Babb Enterprises, Inc.
 RA Address: 712 Wayside Court
 RA City,St,Zip: Franklin, TN 37069
 Worker Caution: Yes
 Acres: 0.344
 Land Use: Industrial/Commercial
 Ground Water Use Restriction:No

MAP FINDINGS

Map ID
 Direction
 Distance
 Distance (ft.)Site

EDR ID Number

Database(s) EPA ID Number

HAFER CLEANERS (Continued)

S111826400

Highway Authority Agreement: No
 Ordinance: Yes
 Industrial - Commercial: Yes
 Slab on Grade: No
 BCT: No
 Building Slab: Yes
 Asphalt Used: Yes
 Concrete Used: No
 Clean Soil 3ft: No
 Clean Soil 10ft: No
 Alternate Barrier: No

IL INSTUTIONAL CONTROL:

Illinois EPA Id: 0430805027
 NFR Letter: 06/28/2013
 Date NFR Recorded: 07/24/2013
 Comprehensive / Focused: Focused
 Remediation Applicant Name: John Babb
 RA Company: Babb Enterprises, Inc.
 RA Address: 712 Wayside Court
 RA City,St,Zip: Franklin, TN 37069
 Worker Caution: Yes
 Acres: 0.344
 Land Use: Industrial/Commercial
 Ground Water Use Restriction: No
 Highway Authority Agreement: No
 Ordinance: Yes
 Industrial - Commercial: Yes
 Slab on Grade: No
 BCT: No
 Building Slab: Yes
 Asphalt Used: Yes
 Concrete Used: No
 Clean Soil 3ft: No
 Clean Soil 10ft: No
 Alternate Barrier: No

SRP:

IL EPA Id: 0430805027
 US EPA Id: ILD981793508
 Longitude: -87.973941
 Latitude: 41.889549
 Contact Name: John Babb
 Contact Address: 712 Wayside Court
 Contact City,St,Zip: Franklin, TN 37069
 Date Enrolled: 09/20/2012
 Point Of Contact: Marie Mueller
 Consultant Company: Mostardi Platt
 Consultant Address: 888 Industrial Drive
 Consultant City,St,Zip: Elmhurst, IL 60126
 Proj Mgr Assigned: Andrew Catlin
 Sec. 4 Letter Date: Not reported
 Active: No
 Remediation Applicant Co: Babb Enterprises, Inc.
 Remediation Applicant Name: John Babb
 Remediation Applicant Company: Babb Enterprises, Inc.

MAP FINDINGS

Map ID
 Direction
 Distance
 Distance (ft.)Site

EDR ID Number
 EPA ID Number

Database(s)

HAFER CLEANERS (Continued)

S111826400

Remediation Applicant Address: 712 Wayside Court
 Remediation Applicant City,St,Zip: Franklin, TN 37069
 Illinois EPA: 0430805027
 Site Name: Hafer Cleaners
 NFR Letter: 2013-06-28
 NFR Letter Date Recorded: 2013-07-24
 Comprehensive/Focused: Focused
 Worker Caution: Yes
 Acres: 0.344
 Land Use: Industrial/Commercial
 Ground Water Use Restriction: No
 Highway Authority Agreement: No
 Ordinance: Yes
 Industrial - Commercial: Yes
 Slab on Grade: No
 BCT: No
 Building Slab: Yes
 Asphalt Used: Yes
 Concrete Used: No
 Clean Soil 3ft: No
 Clean Soil 10ft: No
 Alternate Barrier: No

Click here for IL SRP:

DRYCLEANERS:

Facility Id: 2923-4441-01
 DC No: DC-01137
 Facility Contact: BRIAN YIM
 License Expires: 12/31/2016

28
 West
 1/4-1/2
 0.435 mi.
 2298 ft.

**HARTNETT U-SAVE GAS STATION
 5 WEST PARK BLVD.
 VILLA PARK, IL 60181**

**LUST S104524916
 N/A**

LUST:

Incident Num: 921364
 IL EPA Id: 0430805079
 Product: Unleaded Gas
 IEMA Date: 05/20/1992
 Project Manager: Hamilton
 Project Manager Phone: Not reported
 Email: Not reported
 PRP Name: Hartnett U-Save Gas
 PRP Contact: Tom Hartnett
 PRP Address: P.O. Box 1362
 PRP City,St,Zip: Elmhurst, IL 60126
 PRP Phone: Not reported
 Site Classification: Not reported
 Section 57.5(g) Letter: 731
 Date Section 57.5(g) Letter: Not reported
 Non LUST Determination Letter: Not reported
 20 Report Received: 06/08/1992
 45 Report Received: 12/11/1992

MAP FINDINGS

Map ID
 Direction
 Distance
 Distance (ft.)Site

EDR ID Number

Database(s) EPA ID Number

HARTNETT U-SAVE GAS STATION (Continued)

S104524916

NFA/NFR Letter: 03/17/1994
NFR Date Recorded: Not reported

29
NNW
1/4-1/2
0.451 mi.
2380 ft.

ELMHURST
ELMHURST, IL 60553

SWF/LF S108111341
N/A

IL WMRC_LF:
 Region: WMRC
 General: Not reported
 IEPA ID Number: 439999999
 Municipal Waste: Not reported
 Provisional IEPA ID: 043035000B
 Septic: Not reported
 NIPC Map Number: Not reported
 Animal: Not reported
 Owner Name: NOT AVAILABLE
 Pathological: Not reported
 Operator: NOT AVAILABLE
 Industrial: Not reported
 PO Box: Not reported
 Foundry Sand: Not reported
 Incinerator Ash: Not reported
 Slag: Not reported
 Hazardous: Not reported
 Hazardous Liquid: Not reported
 Radiation: Not reported
 Demolition: Not reported
 Lat/Long: 415324/875830
 Landscaping: Not reported
 Oil Field: Not reported
 Primemer ID: 3
 Special: Not reported
 Township: 38N
 Other: Not reported
 Range: 11E
 Unknown: X
 Section: Not reported
 Quarter Section1: Not reported
 Quarter Section2: Not reported
 Quarter Section3: Not reported
 Quarter Section4: Not reported
 IEPA: Not reported
 ISGS: Not reported
 PollutionControlBoard: Not reported
 IDM&M: Not reported
 DPH: Not reported
 Operational Status: Not reported
 Local Agency: X
 Permit Status: Not reported
 Agency: NIPC
 IEPA Permit Date: Not reported
 Source Other: Not reported
 Close Date: Not reported
 Reaction: Not reported
 RCRA Facility: Not reported

MAP FINDINGS

Map ID
 Direction
 Distance
 Distance (ft.)Site

EDR ID Number

Database(s) EPA ID Number

ELMHURST (Continued)

S108111341

Date Discover: Not reported
 GW Monitoring: Not reported
 Date Cleaned: Not reported
 FD Site: Not reported
 Offsite Waste: Not reported
 Landfill Size: Not reported
 Random Dump: Not reported
 Size Fill: Not reported
 Open Dump: Not reported
 Leachate Collected: Not reported
 Abandonment: Not reported
 Other: Not reported
 Recompacted Clay: Not reported
 In-situ Clay: Not reported
 Secured Containers: Not reported
 Combination: Not reported
 Landfill: Not reported
 None: Not reported
 Incineration: Not reported
 Other: Not reported
 SurFACE Impoundment: Not reported
 Land Application: Not reported

**30
 ENE
 1/4-1/2
 0.457 mi.
 2414 ft.**

**KROTT, EUGENE
 439 MADISON
 VILLA PARK, IL 60181**

**SWF/LF 1008141517
 FINDS N/A
 BOL
 ECHO**

IL WMRC_LF:
 Region: WMRC
 General: X
 IEPA ID Number: 430800001
 Municipal Waste: Not reported
 Provisional IEPA ID: Not reported
 Septic: Not reported
 NIPC Map Number: 304
 Animal: Not reported
 Owner Name: EUGENE KROTT
 Pathological: Not reported
 Operator: EUGENE KROTT
 Industrial: Not reported
 PO Box: Not reported
 Foundry Sand: Not reported
 Incinerator Ash: Not reported
 Slag: Not reported
 Hazardous: Not reported
 Hazardous Liquid: Not reported
 Radiation: Not reported
 Demolition: Not reported
 Lat/Long: 415315/875745
 Landscaping: Not reported
 Oil Field: Not reported
 Primemer ID: 3
 Special: Not reported
 Township: 39N
 Other: Not reported
 Range: 11E

MAP FINDINGS

Map ID
 Direction
 Distance
 Distance (ft.)Site

EDR ID Number
 EPA ID Number

Database(s)

KROTT, EUGENE (Continued)

1008141517

Unknown:	Not reported
Section:	15
Quarter Section1:	NE
Quarter Section2:	Not reported
Quarter Section3:	Not reported
Quarter Section4:	Not reported
IEPA:	X
ISGS:	Not reported
PollutionControlBoard:	Not reported
IDM&M:	Not reported
DPH:	Not reported
Operational Status:	CLOSED FINAL COVER
Local Agency:	Not reported
Permit Status:	UNPERMITTED UNAUTHORIZED
Agency:	NIPC
IEPA Permit Date:	Not reported
Source Other:	Not reported
Close Date:	22376
Reaction:	Not reported
RCRA Facility:	Not reported
Date Discover:	Not reported
GW Monitoring:	NO
Date Cleaned:	Not reported
FD Site:	Not reported
Offsite Waste:	Not reported
Landfill Size:	Not reported
Random Dump:	Not reported
Size Fill:	Not reported
Open Dump:	Not reported
Leachate Collected:	Not reported
Abandonment:	Not reported
Other:	Not reported
Recompacted Clay:	Not reported
In-situ Clay:	Not reported
Secured Containers:	Not reported
Combination:	Not reported
Landfill:	X
None:	Not reported
Incineration:	Not reported
Other:	Not reported
Surface Impoundment:	Not reported
Land Application:	Not reported

FINDS:

Registry ID: 110018382613

Environmental Interest/Information System

ACES (Illinois - Agency Compliance And Enforcement System) is the Illinois EPA Project to facilitate the permitting operations

BOL:

Site Id: 170000560097
 Inv Num: 0430800001
 Interest Name: Krott, Eugene

MAP FINDINGS

Map ID
 Direction
 Distance
 Distance (ft.)Site

EDR ID Number
 EPA ID Number

Database(s)

KROTT, EUGENE (Continued)

1008141517

Interest Type: BOL
 Media Code: LAND

ECHO:

Envid: 1008141517
 Registry ID: 110018382613
 DFR URL: http://echo.epa.gov/detailed_facility_report?fid=110018382613

**I31
 NW
 1/4-1/2
 0.460 mi.
 2428 ft.**

**HEIDEMEIER, ROSALIE ESTATE OF
 109 EAST ST. CHARLES RD.
 VILLA PARK, IL**

RGA LUST

**S115507785
 N/A**

Site 1 of 2 in cluster I

RGA LUST:

2012	HEIDEMEIER, ROSALIE ESTATE OF	109 EAST ST. CHARLES RD.
2011	HEIDEMEIER, ROSALIE ESTATE OF	109 EAST ST. CHARLES RD.
2010	HEIDEMEIER, ROSALIE ESTATE OF	109 EAST ST. CHARLES RD.
2009	HEIDEMEIER, ROSALIE ESTATE OF	109 EAST ST. CHARLES RD.
2008	HEIDEMEIER, ROSALIE ESTATE OF	109 EAST ST. CHARLES RD.
2007	HEIDEMEIER, ROSALIE ESTATE OF	109 EAST ST. CHARLES RD.
2006	HEIDEMEIER, ROSALIE ESTATE OF	109 EAST ST. CHARLES RD.
2005	HEIDEMEIER, ROSALIE ESTATE OF	109 EAST ST. CHARLES RD.
2004	HEIDEMEIER, ROSALIE ESTATE OF	109 EAST ST. CHARLES RD.
2003	HEIDEMEIER, ROSALIE ESTATE OF	109 EAST ST. CHARLES RD.
2002	HEIDEMEIER, ROSALIE ESTATE OF	109 EAST ST. CHARLES RD.
2001	HEIDEMEIER, ROSALIE ESTATE OF	109 EAST ST. CHARLES RD.
2000	HEIDEMEIER, ROSALIE ESTATE OF	109 EAST ST. CHARLES RD.

**I32
 NW
 1/4-1/2
 0.460 mi.
 2428 ft.**

**HEIDEMEIER, ROSALIE ESTATE OF
 109 EAST ST. CHARLES RD.
 VILLA PARK, IL 60181**

LUST

**S104524492
 N/A**

Site 2 of 2 in cluster I

LUST:

Incident Num: 922809
 IL EPA Id: 0430805085
 Product: Gasoline
 IEMA Date: 10/06/1992
 Project Manager: Irwin
 Project Manager Phone: Not reported
 Email: Not reported
 PRP Name: Estate of Rosalie Heidelemier
 PRP Contact: Chuck Brown
 PRP Address: OS 560 Rt. 83
 PRP City,St,Zip: Oak Brook Terrace, IL 60181
 PRP Phone: Not reported
 Site Classification: Not reported
 Section 57.5(g) Letter: 731
 Date Section 57.5(g) Letter: Not reported
 Non LUST Determination Letter: Not reported
 20 Report Received: 01/15/1993
 45 Report Received: 01/15/1993
NFA/NFR Letter: 04/06/1993
 NFR Date Recorded: Not reported

MAP FINDINGS

Map ID			EDR ID Number
Direction			
Distance			
Distance (ft.)	Site	Database(s)	EPA ID Number

33 ENE 1/4-1/2 0.464 mi. 2449 ft.	SALT CREEK SANITARY DIST. 201 SOUTH RT. 83 VILLA PARK, IL	RGA LUST	S115517574 N/A
--	--	-----------------	---------------------------------

RGA LUST:

2012	SALT CREEK SANITARY DIST.	201 SOUTH RT. 83
2011	SALT CREEK SANITARY DIST.	201 SOUTH RT. 83
2010	SALT CREEK SANITARY DIST.	201 SOUTH RT. 83
2009	SALT CREEK SANITARY DIST.	201 SOUTH RT. 83
2008	SALT CREEK SANITARY DIST.	201 SOUTH RT. 83
2007	SALT CREEK SANITARY DIST.	201 SOUTH RT. 83
2006	SALT CREEK SANITARY DIST.	201 SOUTH RT. 83
2005	SALT CREEK SANITARY DIST.	201 SOUTH RT. 83
2004	SALT CREEK SANITARY DIST.	201 SOUTH RT. 83
2003	SALT CREEK SANITARY DIST.	201 SOUTH RT. 83
2002	SALT CREEK SANITARY DIST.	201 SOUTH RT. 83
2001	SALT CREEK SANITARY DIST.	201 SOUTH RT. 83
2000	SALT CREEK SANITARY DIST.	201 SOUTH RT. 83

34 WSW 1/4-1/2 0.468 mi. 2473 ft.	HARTNETT U-SAVE GAS STATION 5 WEST PARK BLVD. VILLA PARK, IL	RGA LUST	S115507667 N/A
--	---	-----------------	---------------------------------

RGA LUST:

2012	HARTNETT U-SAVE GAS STATION	5 WEST PARK BLVD.
2011	HARTNETT U-SAVE GAS STATION	5 WEST PARK BLVD.
2010	HARTNETT U-SAVE GAS STATION	5 WEST PARK BLVD.
2009	HARTNETT U-SAVE GAS STATION	5 WEST PARK BLVD.
2008	HARTNETT U-SAVE GAS STATION	5 WEST PARK BLVD.
2007	HARTNETT U-SAVE GAS STATION	5 WEST PARK BLVD.
2006	HARTNETT U-SAVE GAS STATION	5 WEST PARK BLVD.
2005	HARTNETT U-SAVE GAS STATION	5 WEST PARK BLVD.
2004	HARTNETT U-SAVE GAS STATION	5 WEST PARK BLVD.
2003	HARTNETT U-SAVE GAS STATION	5 WEST PARK BLVD.
2002	HARTNETT U-SAVE GAS STATION	5 WEST PARK BLVD.
2001	HARTNETT U-SAVE GAS STATION	5 WEST PARK BLVD.
2000	HARTNETT U-SAVE GAS STATION	5 WEST PARK BLVD.

J35 ENE 1/4-1/2 0.473 mi. 2498 ft.	ILLINOIS BELL TELEPHONE 631 EAST WILDWOOD ST. VILLA PARK, IL 60181 Site 1 of 2 in cluster J	LUST	S104524700 N/A
---	--	-------------	---------------------------------

LUST:

Incident Num:	922082
IL EPA Id:	0430805078
Product:	Gasoline, Diesel
IEMA Date:	07/30/1992
Project Manager:	Kuhlman
Project Manager Phone:	(217) 785-5715
Email:	Eric.Kuhlman@illinois.gov
PRP Name:	Illinois Bell Telephone
PRP Contact:	Thomas Scheer
PRP Address:	900 North Villa
PRP City,St,Zip:	Villa Park, IL 60181

MAP FINDINGS

Map ID
 Direction
 Distance
 Distance (ft.)Site

EDR ID Number

Database(s) EPA ID Number

ILLINOIS BELL TELEPHONE (Continued)

S104524700

PRP Phone: Not reported
 Site Classification: Not reported
 Section 57.5(g) Letter: 731
 Date Section 57.5(g) Letter: Not reported
 Non LUST Determination Letter: Not reported
 20 Report Received: 08/10/1992
 45 Report Received: 11/23/1992
NFA/NFR Letter: 02/09/2005
 NFR Date Recorded: 03/28/2005

**J36
 ENE
 1/4-1/2
 0.473 mi.
 2498 ft.**

**ILLINOIS BELL TELEPHONE
 631 EAST WILDWOOD ST.
 VILLA PARK, IL**

**RGA LUST S115508749
 N/A**

Site 2 of 2 in cluster J

RGA LUST:

2012	ILLINOIS BELL TELEPHONE	631 EAST WILDWOOD ST.
2011	ILLINOIS BELL TELEPHONE	631 EAST WILDWOOD ST.
2010	ILLINOIS BELL TELEPHONE	631 EAST WILDWOOD ST.
2009	ILLINOIS BELL TELEPHONE	631 EAST WILDWOOD ST.
2008	ILLINOIS BELL TELEPHONE	631 EAST WILDWOOD ST.
2007	ILLINOIS BELL TELEPHONE	631 EAST WILDWOOD ST.
2006	ILLINOIS BELL TELEPHONE	631 EAST WILDWOOD ST.
2005	ILLINOIS BELL TELEPHONE	631 EAST WILDWOOD ST.
2004	ILLINOIS BELL TELEPHONE	631 EAST WILDWOOD ST.
2003	ILLINOIS BELL TELEPHONE	631 EAST WILDWOOD ST.
2002	ILLINOIS BELL TELEPHONE	631 EAST WILDWOOD ST.
2001	ILLINOIS BELL TELEPHONE	631 EAST WILDWOOD ST.
2000	ILLINOIS BELL TELEPHONE	631 EAST WILDWOOD ST.

**37
 ESE
 1/4-1/2
 0.497 mi.
 2624 ft.**

**JUS FUN AMUSEMENTS
 480 SOUTH RT. 83
 OAKBROOK TERRACE, IL**

**RGA LUST S115510138
 N/A**

RGA LUST:

2012	JUS FUN AMUSEMENTS	480 SOUTH RT. 83
2011	JUS FUN AMUSEMENTS	480 SOUTH RT. 83
2010	JUS FUN AMUSEMENTS	480 SOUTH RT. 83
2009	JUS FUN AMUSEMENTS	480 SOUTH RT. 83
2001	JUS FUN AMUSEMENTS	480 SOUTH RT. 83
2000	JUS FUN AMUSEMENTS	480 SOUTH RT. 83

Count: 3 records

ORPHAN SUMMARY

City	EDR ID	Site Name	Site Address	Zip	Database(s)
ELMHURST	S118559141	CROWN METAL MANUFACTURING CO (PARKING LOT IN VILLA PARK)	765 S IL ROUTE 83	60126	INST CONTROL, SRP
LOMBARD	S108966700	LOMBARD VILLAGE OF	SE CORNER OF PARKSIDE AVENUE & MAIN STREET	60148	LUST
VILLA PARK	S118562359	SPARAGNA, PHIL	17 - 19 EAST PARK BOULEVARD	60181	LUST

NOT FOR BLD



Bureau of Land • 1021 North Grand Avenue East • P.O. Box 19276 • Springfield • Illinois • 62794-9276

Uncontaminated Soil Certification by Licensed Professional Engineer or Licensed Professional Geologist for Use of Uncontaminated Soil as Fill in a CCDD or Uncontaminated Soil Fill Operation LPC-663

Revised in accordance with 35 Ill. Adm. Code 1100, as amended by PCB R2012-009 (eff. Aug. 27, 2012)

This certification form is to be used by professional engineers and professional geologists to certify, pursuant to 35 Ill. Adm. Code 1100.205(a)(1)(B), that soil (i) is uncontaminated soil and (ii) is within a pH range of 6.26 to 9.0. If you have questions about this form, please telephone the Bureau of Land Permit Section at 217/524-3300.

This form may be completed online, saved locally, printed and signed, and submitted to prospective clean construction or demolition debris (CCDD) fill operations or uncontaminated soil fill operations.

I. Source Location Information

(Describe the location of the source of the uncontaminated soil)

Project Name: Villa Park Road Reconstruction/Utility Improvements Office Phone Number, if available: _____

Physical Site Location (address, including number and street):
Central Blvd/Myrtle Ave/Cortesi Ave

City: Villa Park State: IL Zip Code: 60181

County: DuPage Township: _____

Lat/Long of approximate center of site in decimal degrees (DD.ddddd) to five decimal places (e.g., 40.67890, -90.12345):

Latitude: 41.885831 Longitude: -87.970416
(Decimal Degrees) (-Decimal Degrees)

Identify how the lat/long data were determined:
 GPS Map Interpolation Photo Interpolation Survey Other

IEPA Site Number(s), if assigned: _____ BOL: _____ BOW: _____ BOA: _____

II. Owner/Operator Information for Source Site

Site Owner
Name: Village of Villa Park
Street Address: 20 S. Ardmore Ave.
PO Box: _____
City: Villa Park State: IL
Zip Code: 60181 Phone: 630.834.8500
Contact: _____
Email, if available: _____

Site Operator
Name: _____
Street Address: _____
PO Box: _____
City: _____ State: _____
Zip Code: _____ Phone: _____
Contact: _____
Email, if available: _____

This Agency is authorized to require this information under Section 4 and Title X of the Environmental Protection Act (415 ILCS 5/4, 5/39). Failure to disclose this information may result in: a civil penalty of not to exceed \$50,000 for the violation and an additional civil penalty of not to exceed \$10,000 for each day during which the violation continues (415 ILCS 5/42). This form has been approved by the Forms LPC 663 Rev. 8/2012 Management Center.

Project Name: Villa Park Road Reconstruction/Utility Improvement

Latitude: 41.885831 Longitude: -87.970416

Uncontaminated Site Certification

III. Basis for Certification and Attachments

For each item listed below, reference the attachments to this form that provide the required information.

- a. A Description of the soil sample points and how they were determined to be sufficient in number and appropriately located [35 Ill. Adm. Code 1100.610(a)]:

Refer to attachment A.1b.

- b. Analytical soil testing results to show that soil chemical constituents comply with the maximum allowable concentrations established pursuant to 35 Ill. Adm. Code Part 1100, Subpart F and that the soil pH is within the range of 6.25 to 9.0, including the documentation of chain of custody control, a copy of the lab analysis; the accreditation status of the laboratory performing the analysis; and certification by an authorized agent of the laboratory that the analysis has been performed in accordance with the Agency's rules for the accreditation of environmental and the scope of the accreditation [35 Ill. Adm. Code 1100.201(g), 1100.205(a), 1100.610]:

Five samples were analyzed for BETX,PNAs,Lead, and field pH. Lab results were below maximum allowable concentrations and within acceptable pH range. See attached reports.

IV. Certification Statement, Signature and Seal of Licensed Professional Engineer or Licensed Professional Geologist

I, Gregory W. Wilcox, P.E. (name of licensed professional engineer or geologist) certify under penalty of law that the information submitted, including but not limited to, all attachments and other information, is to the best of my knowledge and belief, true, accurate and complete. In accordance with the Environmental Protection Act [415 ILCS 5/22.51 or 22.51a] and 35 Ill. Adm. Code 1100.205(a), I certify that the soil from this site is uncontaminated soil. I also certify that the soil pH is within the range of 6.25 to 9.0. In addition, I certify that the soil has not been removed from the site as part of a cleanup or removal of contaminants. All necessary documentation is attached.

Any person who knowingly makes a false, fictitious, or fraudulent material statement, orally or in writing, to the Illinois EPA commits a Class 4 felony. A second or subsequent offense after conviction is a Class 3 felony. (415 ILCS 5/44(h))

Company Name: Winston Engineering

Street Address: 2256 Southwind Blvd

City: Bartlett State: IL Zip Code: 60103

Phone: 630-503-5028

Gregory W. Wilcox, P.E.

Printed Name:

Gregory W. Wilcox

10/5/16

Licensed Professional Engineer or
Licensed Professional Geologist Signature:

Date:



P.E. or L.P.G. Seal:

Appendix A.1a

Certification statement

NOT FOR BID

A.1b

Villa Park Road Reconstruction/Utility Improvements

Central Blvd. /Myrtle Ave. /Cortesi Ave.

Villa Park, IL 60181

Environmental Report 10/4/16

Environmental Database Review

On 9/16/16, Winston Engineering mobilized to conduct a site investigation of material originally generated from the project sites located on Central Blvd., Myrtle Ave., and Cortesi Ave. in Villa Park. The project locations can be found in A.2b. Prior to the site investigation, an Environmental Database Review (EDR) was conducted (see A.5b). After reviewing the EDR report, Winston Engineering found multiple records in close proximity to the project site including leaking underground storage tanks.

Based on the fact the records were located in close proximity to the project sites, the determination was made that additional sampling of the project site was necessary.

Soil Sampling

Eight soil samples were collected at approximate depths of 0 to 5 ft. below grade. The samples were screened for fuels and volatiles with a Photoionization Detector (PID). PID readings were recorded as below background. Based on the composition of the soil and the project site dimensions, eight samples were submitted to Prairie Analytical. Five samples were tested for BTEX, PNAs, Lead, and field pH. The locations of these samples can be found in A.2c.

Conclusion

Lab analysis found that the soil samples had below Maximum Allowable Concentrations of BTEX, PNAs, and Lead along with being in the acceptable pH range of 6.25 to 9.0 for CCDD or USFO disposal. Lab reports can be found in section A.4.

Appendix A.2

Site Maps

A.2b Project Map

A.2c Soil Borings Map

NOT FOR BID

Villa Park Rd. Reconstruction/Utility Improvements

A.2b Project Location Map

E. Willard Ave.

Great Western Trail

E. Kenilworth Ave.

S. Cortesi Ave.

Illinois Prairie Path - Main Stem

Project location

Astor Ct.

S. Euclid Ave.

S Myrtle Ave & Astor Ct

Crescent Dr.

S. Villa Ave.

Google earth

© 2016 Google

S. Oakland Ave

1000 ft

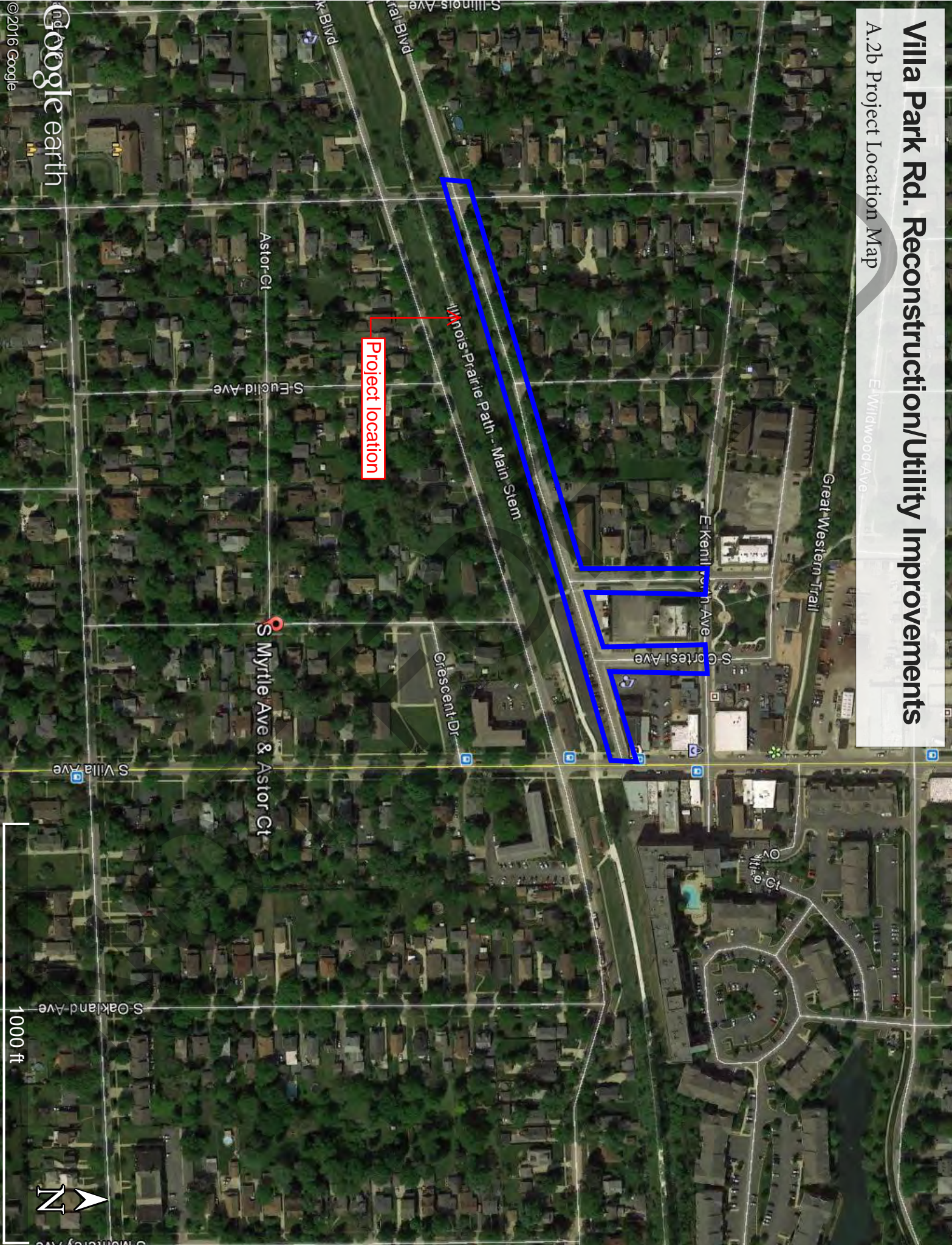

Villa Park Rd. Reconstruction/Utility Improvements

A.2c Soil Borings Map

E. Wildwood Ave.

Great Western Trail

E. Kenilworth Ave.

S. Cross Ave.

Crescent Dr.

Illinois Prairie Path - Main Stem

Project location

S Myrtle Ave & Astor Ct

S Euclid Ave

Astor Ct

V-3

V-4

V-5

V-6

V-7

V-8

V-2

V-1



Appendix A.3

Analytical Tables

A.3b- BETX

A.3c- PNAs

A.3d- Lead/pH

NOT FOR BID

A.3b- BETX

Winston Engineering						WINSTON ENGINEERING 2256 Southwind Blvd Bartlett, IL 60103 Phone: 630-503-5028 Fax: 630-524-9020	
Project: Villa Park Rd Recon-Central Blvd							
Work Order: 1610759							
Chemical Name	CCDD Limits	1610759-01 VP-1 09/28/2016	1610759-02 VP-2 09/28/2016	1610759-04 VP-4 09/28/2016	1610759-05 VP-5 09/28/2016	1610759-07 VP-7 09/28/2016	
BETX							
SW5035/8260B(mg/kg dry)							
Benzene	0.03	< 0.00490	< 0.00415	< 0.00388	< 0.0148	< 0.0164	
Ethylbenzene	13	< 0.00490	< 0.00415	< 0.00388	< 0.0148	< 0.0164	
Toluene	12	< 0.00490	< 0.00415	< 0.00388	< 0.0148	< 0.0164	
Xylenes (total)	5100	< 0.0147	< 0.0124	< 0.0116	< 0.0444	< 0.0492	
Notes:							
All results are reported as mg/kg-dry unless otherwise noted.							
Bold/Shaded results indicate concentrations exceeding CCDD MACS							
CCDD Limits are values of disposal within a populated area in a MSA county excluding Chicago							

NOT FOR

A.3c- PNAS

Winston Engineering		WINSTON ENGINEERING
Project: Villa Park Rd Recon-Central Blvd		WINSTON ENGINEERING
Work Order: 1610759		2256 Southwind Blvd Bartlett, IL 60103 Phone: 630-503-5028 Fax: 630-524-9020
		

Chemical Name	CCDD Limits		1610759-04	1610759-05	1610759-07
	VP-1	VP-2			
	1610759-01	1610759-02	1610759-04	1610759-05	1610759-07
	09/28/2016	09/28/2016	09/28/2016	09/28/2016	09/28/2016

PNAS						
SW8270C (mg/kg dry)	570	< 0.365	< 0.391	< 0.414	< 0.392	< 0.403
Acenaphthene	570	< 0.365	< 0.391	< 0.414	< 0.392	< 0.403
Acenaphthylene	85	< 0.365	< 0.391	< 0.414	< 0.392	< 0.403
Anthracene	12000	< 0.365	< 0.391	< 0.414	< 0.392	< 0.403
Benzo(a)anthracene	0.9	< 0.365	< 0.391	< 0.414	< 0.392	< 0.403
Benzo(b)fluoranthene	0.9	< 0.365	< 0.391	< 0.414	< 0.392	< 0.403
Benzo(k)fluoranthene	9	< 0.365	< 0.391	< 0.414	< 0.392	< 0.403
Benzo(g,h,i)perylene	2300	< 0.365	< 0.391	< 0.414	< 0.392	< 0.403
Benzo(a)pyrene	2.1	< 0.0657	< 0.0704	< 0.0746	< 0.0706	< 0.0725
Chrysene	88	< 0.365	< 0.391	< 0.414	< 0.392	< 0.403
Dibenz(a,h)anthracene	0.09	< 0.0657	< 0.0704	< 0.0746	< 0.0706	< 0.0725
Fluoranthene	3100	< 0.365	< 0.391	< 0.414	< 0.392	< 0.403
Fluorene	560	< 0.365	< 0.391	< 0.414	< 0.392	< 0.403
Indeno(1,2,3-cd)pyrene	0.9	< 0.365	< 0.391	< 0.414	< 0.392	< 0.403
Naphthalene	1.8	< 0.365	< 0.391	< 0.414	< 0.392	< 0.403
Phenanthrene	210	< 0.365	< 0.391	< 0.414	< 0.392	< 0.403
Pyrene	2300	< 0.365	< 0.391	< 0.414	< 0.392	< 0.403

Notes:

All results are reported as mg/kg-dry unless otherwise noted.

Bold/Shaded results indicate concentrations exceeding CCDD MACS

CCDD Limits are values of disposal within a populated area in a MSA county excluding Chicago

A.3d - Lead/pH

Winston Engineering				 WINSTON ENGINEERING 2256 Southwind Blvd Bartlett, IL 60103 Phone: 630-503-5028 Fax: 630-524-9020			
Project: Villa Park Rd Recon-Central Blvd							
Work Order: 1610759							
Chemical Name	CCDD Limits	1610759-01 VP-1 09/28/2016	1610759-02 VP-2 09/28/2016	1610759-04 VP-4 09/28/2016	1610759-05 VP-5 09/28/2016	1610759-07 VP-7 09/28/2016	
INORG							
ASTM D2974 (%)							
Percent Solids	~	88.5	84.7	79.7	84.4	80.6	
SW6010B (mg/kg dry)							
Lead	107	39.6	13.8	14.3	44.0	27.6	
NY Dot GTM-24							
pH	6.25-9	7.68	7.63	7.56	7.39	7.22	
Notes:	All results are reported as mg/kg-dry unless otherwise noted.						
	Bold/Shaded results indicate concentrations exceeding CCDD MACS						
	CCDD Limits are values of disposal within a populated area in a MSA county excluding Chicago						

NOT FOR

Appendix A.4

Lab Reports

A.4b- BETX/PNAs/Lead

A.4c pH

NOT FOR BID



A.4b- BETX/PNAs/Lead

Monday, October 3, 2016

Andy Paxson
Winston Engineering
2250 Southwind Boulevard
Bartlett, IL 60103
TEL: (630) 917-1158
FAX: (630) 524-9020

RE: Villa Park Rd Recon-Central Blvd

PAS WO: 1610759

Prairie Analytical Systems, Inc. received 8 sample(s) on 9/29/2016 for the analyses presented in the following report.

All applicable quality control procedures met method specific acceptance criteria unless otherwise noted.

This report shall not be reproduced, except in full, without the prior written consent of Prairie Analytical Systems, Inc.

If you have any questions, please feel free to contact me at (217) 753-1148.

Respectfully submitted,

Kristen A. Potter
Project Manager

Certifications: NELAP/NELAC - IL #100323

1210 Capital Airport Drive	*	Springfield, IL 62707	*	1.217.753.1148	*	1.217.753.1152 Fax
9114 Virginia Road Suite #112	*	Lake in the Hills, IL 60156	*	1.847.651.2604	*	1.847.458.0538 Fax

LABORATORY RESULTS

Client: Winston Engineering
Project: Villa Park Rd Recon-Central Blvd
Client Sample ID: VP-1
Collection Date: 9/28/16 8:45

Lab Order: 16I0759
Lab ID: 16I0759-01
Matrix: Solid

Analyses	Result	Limit	Qual	Units	DF	Date Prepared	Date Analyzed	Method	Analyst
Volatile Organic Compounds by GC-MS									
*Benzene	U	0.00490		mg/Kg dry	1	9/30/16 12:30	9/30/16 15:46	SW8260B Re	JLS
*Ethylbenzene	U	0.00490		mg/Kg dry	1	9/30/16 12:30	9/30/16 15:46	SW8260B Re	JLS
*Toluene	U	0.00490		mg/Kg dry	1	9/30/16 12:30	9/30/16 15:46	SW8260B Re	JLS
*Xylenes (total)	U	0.0147		mg/Kg dry	1	9/30/16 12:30	9/30/16 15:46	SW8260B Re	JLS
<i>Surrogate: 4-Bromofluorobenzene</i>		75 %		75-120		9/30/16 12:30	9/30/16 15:46	SW8260B Re	JLS
<i>Surrogate: 1,2-Dichloroethane-d4</i>		120 % S2		75-119		9/30/16 12:30	9/30/16 15:46	SW8260B Re	JLS
<i>Surrogate: Toluene-d8</i>		121 % S2		78-114		9/30/16 12:30	9/30/16 15:46	SW8260B Re	JLS
Semi-Volatile Organic Compounds by GC-MS									
*Acenaphthene	U	0.365		mg/Kg dry	1	9/30/16 14:07	9/30/16 20:33	SW8270C	AJD
*Acenaphthylene	U	0.365		mg/Kg dry	1	9/30/16 14:07	9/30/16 20:33	SW8270C	AJD
*Anthracene	U	0.365		mg/Kg dry	1	9/30/16 14:07	9/30/16 20:33	SW8270C	AJD
*Benzo(a)anthracene	U	0.365		mg/Kg dry	1	9/30/16 14:07	9/30/16 20:33	SW8270C	AJD
*Benzo(b)fluoranthene	U	0.365		mg/Kg dry	1	9/30/16 14:07	9/30/16 20:33	SW8270C	AJD
*Benzo(k)fluoranthene	U	0.365		mg/Kg dry	1	9/30/16 14:07	9/30/16 20:33	SW8270C	AJD
*Benzo(g,h,i)perylene	U	0.365		mg/Kg dry	1	9/30/16 14:07	9/30/16 20:33	SW8270C	AJD
*Benzo(a)pyrene	U	0.0657		mg/Kg dry	1	9/30/16 14:07	9/30/16 20:33	SW8270C	AJD
*Chrysene	U	0.365		mg/Kg dry	1	9/30/16 14:07	9/30/16 20:33	SW8270C	AJD
*Dibenz(a,h)anthracene	U	0.0657		mg/Kg dry	1	9/30/16 14:07	9/30/16 20:33	SW8270C	AJD
*Fluoranthene	U	0.365		mg/Kg dry	1	9/30/16 14:07	9/30/16 20:33	SW8270C	AJD
*Fluorene	U	0.365		mg/Kg dry	1	9/30/16 14:07	9/30/16 20:33	SW8270C	AJD
*Indeno(1,2,3-cd)pyrene	U	0.365		mg/Kg dry	1	9/30/16 14:07	9/30/16 20:33	SW8270C	AJD
*Naphthalene	U	0.365		mg/Kg dry	1	9/30/16 14:07	9/30/16 20:33	SW8270C	AJD
*Phenanthrene	U	0.365		mg/Kg dry	1	9/30/16 14:07	9/30/16 20:33	SW8270C	AJD
*Pyrene	U	0.365		mg/Kg dry	1	9/30/16 14:07	9/30/16 20:33	SW8270C	AJD
<i>Surrogate: 2-Fluorobiphenyl</i>		56 %		38-122		9/30/16 14:07	9/30/16 20:33	SW8270C	AJD
<i>Surrogate: Nitrobenzene-d5</i>		67 %		45-136		9/30/16 14:07	9/30/16 20:33	SW8270C	AJD
<i>Surrogate: 4-Terphenyl-d14</i>		75 %		57-122		9/30/16 14:07	9/30/16 20:33	SW8270C	AJD
Metals by ICP									
*Lead	39.6	0.262		mg/Kg dry	1	9/30/16 12:30	10/3/16 11:18	SW6010B	JTC
Conventional Chemistry Parameters									
Percent Solids	88.5	0.100		%	1	9/30/16 14:35	10/3/16 9:58	ASTM D2974	ADH

LABORATORY RESULTS

Client: Winston Engineering
Project: Villa Park Rd Recon-Central Blvd
Client Sample ID: VP-2
Collection Date: 9/28/16 9:30

Lab Order: 16I0759
Lab ID: 16I0759-02
Matrix: Solid

Analyses	Result	Limit	Qual	Units	DF	Date Prepared	Date Analyzed	Method	Analyst
Volatile Organic Compounds by GC-MS									
*Benzene	U	0.00415		mg/Kg dry	1	9/30/16 12:30	9/30/16 16:16	SW8260B Re	JLS
*Ethylbenzene	U	0.00415		mg/Kg dry	1	9/30/16 12:30	9/30/16 16:16	SW8260B Re	JLS
*Toluene	U	0.00415		mg/Kg dry	1	9/30/16 12:30	9/30/16 16:16	SW8260B Re	JLS
*Xylenes (total)	U	0.0124		mg/Kg dry	1	9/30/16 12:30	9/30/16 16:16	SW8260B Re	JLS
Surrogate: 4-Bromofluorobenzene		96 %		75-120		9/30/16 12:30	9/30/16 16:16	SW8260B Re	JLS
Surrogate: 1,2-Dichloroethane-d4		118 %		75-119		9/30/16 12:30	9/30/16 16:16	SW8260B Re	JLS
Surrogate: Toluene-d8		103 %		78-114		9/30/16 12:30	9/30/16 16:16	SW8260B Re	JLS
Semi-Volatile Organic Compounds by GC-MS									
*Acenaphthene	U	0.391		mg/Kg dry	1	9/30/16 14:07	9/30/16 21:04	SW8270C	AJD
*Acenaphthylene	U	0.391		mg/Kg dry	1	9/30/16 14:07	9/30/16 21:04	SW8270C	AJD
*Anthracene	U	0.391		mg/Kg dry	1	9/30/16 14:07	9/30/16 21:04	SW8270C	AJD
*Benzo(a)anthracene	U	0.391		mg/Kg dry	1	9/30/16 14:07	9/30/16 21:04	SW8270C	AJD
*Benzo(b)fluoranthene	U	0.391		mg/Kg dry	1	9/30/16 14:07	9/30/16 21:04	SW8270C	AJD
*Benzo(k)fluoranthene	U	0.391		mg/Kg dry	1	9/30/16 14:07	9/30/16 21:04	SW8270C	AJD
*Benzo(g,h,i)perylene	U	0.391		mg/Kg dry	1	9/30/16 14:07	9/30/16 21:04	SW8270C	AJD
*Benzo(a)pyrene	U	0.0704		mg/Kg dry	1	9/30/16 14:07	9/30/16 21:04	SW8270C	AJD
*Chrysene	U	0.391		mg/Kg dry	1	9/30/16 14:07	9/30/16 21:04	SW8270C	AJD
*Dibenz(a,h)anthracene	U	0.0704		mg/Kg dry	1	9/30/16 14:07	9/30/16 21:04	SW8270C	AJD
*Fluoranthene	U	0.391		mg/Kg dry	1	9/30/16 14:07	9/30/16 21:04	SW8270C	AJD
*Fluorene	U	0.391		mg/Kg dry	1	9/30/16 14:07	9/30/16 21:04	SW8270C	AJD
*Indeno(1,2,3-cd)pyrene	U	0.391		mg/Kg dry	1	9/30/16 14:07	9/30/16 21:04	SW8270C	AJD
*Naphthalene	U	0.391		mg/Kg dry	1	9/30/16 14:07	9/30/16 21:04	SW8270C	AJD
*Phenanthrene	U	0.391		mg/Kg dry	1	9/30/16 14:07	9/30/16 21:04	SW8270C	AJD
*Pyrene	U	0.391		mg/Kg dry	1	9/30/16 14:07	9/30/16 21:04	SW8270C	AJD
Surrogate: 2-Fluorobiphenyl		70 %		38-122		9/30/16 14:07	9/30/16 21:04	SW8270C	AJD
Surrogate: Nitrobenzene-d5		90 %		45-136		9/30/16 14:07	9/30/16 21:04	SW8270C	AJD
Surrogate: 4-Terphenyl-d14		79 %		57-122		9/30/16 14:07	9/30/16 21:04	SW8270C	AJD
Metals by ICP									
*Lead	13.8	0.270		mg/Kg dry	1	9/30/16 12:30	10/3/16 11:24	SW6010B	JTC
Conventional Chemistry Parameters									
Percent Solids	84.7	0.100		%	1	9/30/16 14:35	10/3/16 9:58	ASTM D2974	ADH

LABORATORY RESULTS

Client: Winston Engineering
Project: Villa Park Rd Recon-Central Blvd
Client Sample ID: VP-4
Collection Date: 9/28/16 9:55

Lab Order: 16I0759
Lab ID: 16I0759-04
Matrix: Solid

Analyses	Result	Limit	Qual	Units	DF	Date Prepared	Date Analyzed	Method	Analyst
Volatile Organic Compounds by GC-MS									
*Benzene	U	0.00388		mg/Kg dry	1	9/30/16 12:30	9/30/16 16:46	SW8260B Re	JLS
*Ethylbenzene	U	0.00388		mg/Kg dry	1	9/30/16 12:30	9/30/16 16:46	SW8260B Re	JLS
*Toluene	U	0.00388		mg/Kg dry	1	9/30/16 12:30	9/30/16 16:46	SW8260B Re	JLS
*Xylenes (total)	U	0.0116		mg/Kg dry	1	9/30/16 12:30	9/30/16 16:46	SW8260B Re	JLS
<i>Surrogate: 4-Bromofluorobenzene</i>		80 %		75-120		9/30/16 12:30	9/30/16 16:46	SW8260B Re	JLS
<i>Surrogate: 1,2-Dichloroethane-d4</i>		120 % S2		75-119		9/30/16 12:30	9/30/16 16:46	SW8260B Re	JLS
<i>Surrogate: Toluene-d8</i>		110 %		78-114		9/30/16 12:30	9/30/16 16:46	SW8260B Re	JLS
Semi-Volatile Organic Compounds by GC-MS									
*Acenaphthene	U	0.414		mg/Kg dry	1	9/30/16 14:07	9/30/16 21:35	SW8270C	AJD
*Acenaphthylene	U	0.414		mg/Kg dry	1	9/30/16 14:07	9/30/16 21:35	SW8270C	AJD
*Anthracene	U	0.414		mg/Kg dry	1	9/30/16 14:07	9/30/16 21:35	SW8270C	AJD
*Benzo(a)anthracene	U	0.414		mg/Kg dry	1	9/30/16 14:07	9/30/16 21:35	SW8270C	AJD
*Benzo(b)fluoranthene	U	0.414		mg/Kg dry	1	9/30/16 14:07	9/30/16 21:35	SW8270C	AJD
*Benzo(k)fluoranthene	U	0.414		mg/Kg dry	1	9/30/16 14:07	9/30/16 21:35	SW8270C	AJD
*Benzo(g,h,i)perylene	U	0.414		mg/Kg dry	1	9/30/16 14:07	9/30/16 21:35	SW8270C	AJD
*Benzo(a)pyrene	U	0.0746		mg/Kg dry	1	9/30/16 14:07	9/30/16 21:35	SW8270C	AJD
*Chrysene	U	0.414		mg/Kg dry	1	9/30/16 14:07	9/30/16 21:35	SW8270C	AJD
*Dibenz(a,h)anthracene	U	0.0746		mg/Kg dry	1	9/30/16 14:07	9/30/16 21:35	SW8270C	AJD
*Fluoranthene	U	0.414		mg/Kg dry	1	9/30/16 14:07	9/30/16 21:35	SW8270C	AJD
*Fluorene	U	0.414		mg/Kg dry	1	9/30/16 14:07	9/30/16 21:35	SW8270C	AJD
*Indeno(1,2,3-cd)pyrene	U	0.414		mg/Kg dry	1	9/30/16 14:07	9/30/16 21:35	SW8270C	AJD
*Naphthalene	U	0.414		mg/Kg dry	1	9/30/16 14:07	9/30/16 21:35	SW8270C	AJD
*Phenanthrene	U	0.414		mg/Kg dry	1	9/30/16 14:07	9/30/16 21:35	SW8270C	AJD
*Pyrene	U	0.414		mg/Kg dry	1	9/30/16 14:07	9/30/16 21:35	SW8270C	AJD
<i>Surrogate: 2-Fluorobiphenyl</i>		60 %		38-122		9/30/16 14:07	9/30/16 21:35	SW8270C	AJD
<i>Surrogate: Nitrobenzene-d5</i>		80 %		45-136		9/30/16 14:07	9/30/16 21:35	SW8270C	AJD
<i>Surrogate: 4-Terphenyl-d14</i>		73 %		57-122		9/30/16 14:07	9/30/16 21:35	SW8270C	AJD
Metals by ICP									
*Lead	14.3	0.306		mg/Kg dry	1	9/30/16 12:30	10/3/16 11:30	SW6010B	JTC
Conventional Chemistry Parameters									
Percent Solids	79.7	0.100		%	1	9/30/16 14:35	10/3/16 9:58	ASTM D2974	ADH

LABORATORY RESULTS

Client: Winston Engineering
Project: Villa Park Rd Recon-Central Blvd
Client Sample ID: VP-5
Collection Date: 9/28/16 10:05

Lab Order: 16I0759
Lab ID: 16I0759-05
Matrix: Solid

Analyses	Result	Limit	Qual	Units	DF	Date Prepared	Date Analyzed	Method	Analyst
Volatile Organic Compounds by GC-MS									
*Benzene	U	0.0148		mg/Kg dry	1	9/30/16 12:30	9/30/16 17:16	SW8260B Re	JLS
*Ethylbenzene	U	0.0148		mg/Kg dry	1	9/30/16 12:30	9/30/16 17:16	SW8260B Re	JLS
*Toluene	U	0.0148		mg/Kg dry	1	9/30/16 12:30	9/30/16 17:16	SW8260B Re	JLS
*Xylenes (total)	U	0.0444		mg/Kg dry	1	9/30/16 12:30	9/30/16 17:16	SW8260B Re	JLS
Surrogate: 4-Bromofluorobenzene		102 %		75-120		9/30/16 12:30	9/30/16 17:16	SW8260B Re	JLS
Surrogate: 1,2-Dichloroethane-d4		105 %		75-119		9/30/16 12:30	9/30/16 17:16	SW8260B Re	JLS
Surrogate: Toluene-d8		100 %		78-114		9/30/16 12:30	9/30/16 17:16	SW8260B Re	JLS
Semi-Volatile Organic Compounds by GC-MS									
*Acenaphthene	U	0.392		mg/Kg dry	1	9/30/16 14:07	9/30/16 22:06	SW8270C	AJD
*Acenaphthylene	U	0.392		mg/Kg dry	1	9/30/16 14:07	9/30/16 22:06	SW8270C	AJD
*Anthracene	U	0.392		mg/Kg dry	1	9/30/16 14:07	9/30/16 22:06	SW8270C	AJD
*Benzo(a)anthracene	U	0.392		mg/Kg dry	1	9/30/16 14:07	9/30/16 22:06	SW8270C	AJD
*Benzo(b)fluoranthene	U	0.392		mg/Kg dry	1	9/30/16 14:07	9/30/16 22:06	SW8270C	AJD
*Benzo(k)fluoranthene	U	0.392		mg/Kg dry	1	9/30/16 14:07	9/30/16 22:06	SW8270C	AJD
*Benzo(g,h,i)perylene	U	0.392		mg/Kg dry	1	9/30/16 14:07	9/30/16 22:06	SW8270C	AJD
*Benzo(a)pyrene	U	0.0706		mg/Kg dry	1	9/30/16 14:07	9/30/16 22:06	SW8270C	AJD
*Chrysene	U	0.392		mg/Kg dry	1	9/30/16 14:07	9/30/16 22:06	SW8270C	AJD
*Dibenz(a,h)anthracene	U	0.0706		mg/Kg dry	1	9/30/16 14:07	9/30/16 22:06	SW8270C	AJD
*Fluoranthene	U	0.392		mg/Kg dry	1	9/30/16 14:07	9/30/16 22:06	SW8270C	AJD
*Fluorene	U	0.392		mg/Kg dry	1	9/30/16 14:07	9/30/16 22:06	SW8270C	AJD
*Indeno(1,2,3-cd)pyrene	U	0.392		mg/Kg dry	1	9/30/16 14:07	9/30/16 22:06	SW8270C	AJD
*Naphthalene	U	0.392		mg/Kg dry	1	9/30/16 14:07	9/30/16 22:06	SW8270C	AJD
*Phenanthrene	U	0.392		mg/Kg dry	1	9/30/16 14:07	9/30/16 22:06	SW8270C	AJD
*Pyrene	U	0.392		mg/Kg dry	1	9/30/16 14:07	9/30/16 22:06	SW8270C	AJD
Surrogate: 2-Fluorobiphenyl		49 %		38-122		9/30/16 14:07	9/30/16 22:06	SW8270C	AJD
Surrogate: Nitrobenzene-d5		56 %		45-136		9/30/16 14:07	9/30/16 22:06	SW8270C	AJD
Surrogate: 4-Terphenyl-d14		66 %		57-122		9/30/16 14:07	9/30/16 22:06	SW8270C	AJD
Metals by ICP									
*Lead	44.0	0.272		mg/Kg dry	1	9/30/16 12:30	10/3/16 11:35	SW6010B	JTC
Conventional Chemistry Parameters									
Percent Solids	84.4	0.100		%	1	9/30/16 14:35	10/3/16 9:58	ASTM D2974	ADH

LABORATORY RESULTS

Client: Winston Engineering
 Project: Villa Park Rd Recon-Central Blvd
 Client Sample ID: VP-7
 Collection Date: 9/28/16 10:25

Lab Order: 16I0759
 Lab ID: 16I0759-07
 Matrix: Solid

Analyses	Result	Limit	Qual	Units	DF	Date Prepared	Date Analyzed	Method	Analyst
Volatile Organic Compounds by GC-MS									
*Benzene	U	0.0164		mg/Kg dry	1	9/30/16 12:30	9/30/16 17:46	SW8260B Re	JLS
*Ethylbenzene	U	0.0164		mg/Kg dry	1	9/30/16 12:30	9/30/16 17:46	SW8260B Re	JLS
*Toluene	U	0.0164		mg/Kg dry	1	9/30/16 12:30	9/30/16 17:46	SW8260B Re	JLS
*Xylenes (total)	U	0.0492		mg/Kg dry	1	9/30/16 12:30	9/30/16 17:46	SW8260B Re	JLS
Surrogate: 4-Bromofluorobenzene		105 %		75-120		9/30/16 12:30	9/30/16 17:46	SW8260B Re	JLS
Surrogate: 1,2-Dichloroethane-d4		104 %		75-119		9/30/16 12:30	9/30/16 17:46	SW8260B Re	JLS
Surrogate: Toluene-d8		96 %		78-114		9/30/16 12:30	9/30/16 17:46	SW8260B Re	JLS
Semi-Volatile Organic Compounds by GC-MS									
*Acenaphthene	U	0.403		mg/Kg dry	1	9/30/16 14:07	9/30/16 22:37	SW8270C	AJD
*Acenaphthylene	U	0.403		mg/Kg dry	1	9/30/16 14:07	9/30/16 22:37	SW8270C	AJD
*Anthracene	U	0.403		mg/Kg dry	1	9/30/16 14:07	9/30/16 22:37	SW8270C	AJD
*Benzo(a)anthracene	U	0.403		mg/Kg dry	1	9/30/16 14:07	9/30/16 22:37	SW8270C	AJD
*Benzo(b)fluoranthene	U	0.403		mg/Kg dry	1	9/30/16 14:07	9/30/16 22:37	SW8270C	AJD
*Benzo(k)fluoranthene	U	0.403		mg/Kg dry	1	9/30/16 14:07	9/30/16 22:37	SW8270C	AJD
*Benzo(g,h,i)perylene	U	0.403		mg/Kg dry	1	9/30/16 14:07	9/30/16 22:37	SW8270C	AJD
*Benzo(a)pyrene	U	0.0725		mg/Kg dry	1	9/30/16 14:07	9/30/16 22:37	SW8270C	AJD
*Chrysene	U	0.403		mg/Kg dry	1	9/30/16 14:07	9/30/16 22:37	SW8270C	AJD
*Dibenz(a,h)anthracene	U	0.0725		mg/Kg dry	1	9/30/16 14:07	9/30/16 22:37	SW8270C	AJD
*Fluoranthene	U	0.403		mg/Kg dry	1	9/30/16 14:07	9/30/16 22:37	SW8270C	AJD
*Fluorene	U	0.403		mg/Kg dry	1	9/30/16 14:07	9/30/16 22:37	SW8270C	AJD
*Indeno(1,2,3-cd)pyrene	U	0.403		mg/Kg dry	1	9/30/16 14:07	9/30/16 22:37	SW8270C	AJD
*Naphthalene	U	0.403		mg/Kg dry	1	9/30/16 14:07	9/30/16 22:37	SW8270C	AJD
*Phenanthrene	U	0.403		mg/Kg dry	1	9/30/16 14:07	9/30/16 22:37	SW8270C	AJD
*Pyrene	U	0.403		mg/Kg dry	1	9/30/16 14:07	9/30/16 22:37	SW8270C	AJD
Surrogate: 2-Fluorobiphenyl		54 %		38-122		9/30/16 14:07	9/30/16 22:37	SW8270C	AJD
Surrogate: Nitrobenzene-d5		66 %		45-136		9/30/16 14:07	9/30/16 22:37	SW8270C	AJD
Surrogate: 4-Terphenyl-d14		69 %		57-122		9/30/16 14:07	9/30/16 22:37	SW8270C	AJD
Metals by ICP									
*Lead	27.6	0.302		mg/Kg dry	1	9/30/16 12:30	10/3/16 11:41	SW6010B	JTC
Conventional Chemistry Parameters									
Percent Solids	80.6	0.100		%	1	9/30/16 14:35	10/3/16 9:58	ASTM D2974	ADH

LABORATORY RESULTS

Client: Winston Engineering
 Project: Villa Park Rd Recon-Central Blvd

Lab Order: 1610759

Volatile Organic Compounds by GC-MS - Quality Control

Analyte	Result	Reporting Limit	Units	Spike Level	Source Result	%REC	%REC Limits	RPD	RPD Limit	Notes
---------	--------	-----------------	-------	-------------	---------------	------	-------------	-----	-----------	-------

Batch Z005807 - SW 5035A VOA

Blank (Z005807-BLK1)

Prepared & Analyzed: 09/30/2016

Benzene	U	0.00500	mg/Kg wet							
Ethylbenzene	U	0.00500	mg/Kg wet							
Toluene	U	0.00500	mg/Kg wet							
Xylenes (total)	U	0.0150	mg/Kg wet							
Surrogate: 4-Bromofluorobenzene	0.0544		mg/Kg wet	0.050000		109	75-120			
Surrogate: 1,2-Dichloroethane-d4	0.0498		mg/Kg wet	0.050000		100	75-119			
Surrogate: Toluene-d8	0.0470		mg/Kg wet	0.050000		94	78-114			

LCS (Z005807-BS1)

Prepared & Analyzed: 09/30/2016

Benzene	0.0419	0.00500	mg/Kg wet	0.050000		84	80-130			
Ethylbenzene	0.0435	0.00500	mg/Kg wet	0.050000		87	77-132			
Toluene	0.0402	0.00500	mg/Kg wet	0.050000		80	80-130			
Xylenes (total)	0.135	0.0150	mg/Kg wet	0.15000		90	80-130			
Surrogate: 4-Bromofluorobenzene	0.0529		mg/Kg wet	0.050000		106	75-120			
Surrogate: 1,2-Dichloroethane-d4	0.0473		mg/Kg wet	0.050000		95	75-119			
Surrogate: Toluene-d8	0.0460		mg/Kg wet	0.050000		92	78-114			

Matrix Spike (Z005807-MS1)

Source: 1610728-01RE1

Prepared & Analyzed: 09/30/2016

Benzene	0.0643	0.0119	mg/Kg wet	0.11905	ND	54	50-140			
Ethylbenzene	0.0446	0.0119	mg/Kg wet	0.11905	ND	37	50-140			S
Toluene	0.0559	0.0119	mg/Kg wet	0.11905	ND	47	55-135			S
Xylenes (total)	0.119	0.0357	mg/Kg wet	0.35714	ND	33	60-130			S
Surrogate: 4-Bromofluorobenzene	0.106		mg/Kg wet	0.11905		89	75-120			
Surrogate: 1,2-Dichloroethane-d4	0.129		mg/Kg wet	0.11905		109	75-119			
Surrogate: Toluene-d8	0.124		mg/Kg wet	0.11905		104	78-114			

Matrix Spike Dup (Z005807-MSD1)

Source: 1610728-01RE1

Prepared & Analyzed: 09/30/2016

Benzene	0.0768	0.0106	mg/Kg wet	0.10593	ND	73	50-140	18	20	
Ethylbenzene	0.0700	0.0106	mg/Kg wet	0.10593	ND	66	50-140	44	20	R
Toluene	0.0804	0.0106	mg/Kg wet	0.10593	ND	76	55-135	36	20	R
Xylenes (total)	0.204	0.0318	mg/Kg wet	0.31780	ND	64	60-130	53	20	R
Surrogate: 4-Bromofluorobenzene	0.0925		mg/Kg wet	0.10593		87	75-120			
Surrogate: 1,2-Dichloroethane-d4	0.105		mg/Kg wet	0.10593		99	75-119			
Surrogate: Toluene-d8	0.118		mg/Kg wet	0.10593		111	78-114			

LABORATORY RESULTS

Client: Winston Engineering
 Project: Villa Park Rd Recon-Central Blvd Lab Order: 1610759
 Semi-Volatile Organic Compounds by GC-MS - Quality Control

Analyte	Result	Reporting Limit	Units	Spike Level	Source Result	%REC	%REC Limits	RPD	RPD Limit	Notes
---------	--------	-----------------	-------	-------------	---------------	------	-------------	-----	-----------	-------

Batch Z005803 - SW 3550B PNA

Blank (Z005803-BLK1)

Prepared & Analyzed: 09/30/2016

Acenaphthene	U	0.333	mg/Kg wet							
Acenaphthylene	U	0.333	mg/Kg wet							
Anthracene	U	0.333	mg/Kg wet							
Benzo(a)anthracene	U	0.333	mg/Kg wet							
Benzo(b)fluoranthene	U	0.333	mg/Kg wet							
Benzo(k)fluoranthene	U	0.333	mg/Kg wet							
Benzo(g,h,i)perylene	U	0.333	mg/Kg wet							
Benzo(a)pyrene	U	0.0600	mg/Kg wet							
Chrysene	U	0.333	mg/Kg wet							
Dibenz(a,h)anthracene	U	0.0600	mg/Kg wet							
Fluoranthene	U	0.333	mg/Kg wet							
Fluorene	U	0.333	mg/Kg wet							
Indeno(1,2,3-cd)pyrene	U	0.333	mg/Kg wet							
Naphthalene	U	0.333	mg/Kg wet							
Phenanthrene	U	0.333	mg/Kg wet							
Pyrene	U	0.333	mg/Kg wet							
Surrogate: 2-Fluorobiphenyl	0.505		mg/Kg wet	0.66667		76	38-122			
Surrogate: Nitrobenzene-d5	0.615		mg/Kg wet	0.66667		92	45-136			
Surrogate: 4-Terphenyl-d14	0.517		mg/Kg wet	0.66667		78	57-122			

LCS (Z005803-BS1)

Prepared & Analyzed: 09/30/2016

Acenaphthene	0.862	0.333	mg/Kg wet	0.66667		129	50-135			
Acenaphthylene	0.696	0.333	mg/Kg wet	0.66667		104	51-134			
Anthracene	0.849	0.333	mg/Kg wet	0.66667		127	52-117			S1
Benzo(a)anthracene	0.719	0.333	mg/Kg wet	0.66667		108	50-126			
Benzo(b)fluoranthene	0.948	0.333	mg/Kg wet	0.66667		142	57-134			S1
Benzo(k)fluoranthene	0.953	0.333	mg/Kg wet	0.66667		143	59-168			
Benzo(g,h,i)perylene	0.707	0.333	mg/Kg wet	0.66667		106	56-147			
Benzo(a)pyrene	0.964	0.0600	mg/Kg wet	0.66667		145	41-133			S1
Chrysene	0.430	0.333	mg/Kg wet	0.66667		64	52-127			
Dibenz(a,h)anthracene	0.422	0.0600	mg/Kg wet	0.66667		63	60-170			
Fluoranthene	0.740	0.333	mg/Kg wet	0.66667		111	57-130			
Fluorene	0.659	0.333	mg/Kg wet	0.66667		99	47-154			
Indeno(1,2,3-cd)pyrene	0.817	0.333	mg/Kg wet	0.66667		122	59-132			
Naphthalene	0.782	0.333	mg/Kg wet	0.66667		117	40-135			
Phenanthrene	0.838	0.333	mg/Kg wet	0.66667		126	54-126			
Pyrene	0.875	0.333	mg/Kg wet	0.66667		131	57-132			
Surrogate: 2-Fluorobiphenyl	0.518		mg/Kg wet	0.66667		78	38-122			
Surrogate: Nitrobenzene-d5	0.591		mg/Kg wet	0.66667		89	45-136			
Surrogate: 4-Terphenyl-d14	0.585		mg/Kg wet	0.66667		88	57-122			

LABORATORY RESULTS

Client: Winston Engineering
 Project: Villa Park Rd Recon-Central Blvd Lab Order: 1610759
 Semi-Volatile Organic Compounds by GC-MS - Quality Control

Analyte	Result	Reporting Limit	Units	Spike Level	Source Result	%REC	%REC Limits	RPD	RPD Limit	Notes
---------	--------	-----------------	-------	-------------	---------------	------	-------------	-----	-----------	-------

Batch Z005803 - SW 3550B PNA

Matrix Spike (Z005803-MS1)	Source: 1610759-05			Prepared & Analyzed: 09/30/2016						
Acenaphthene	0.962	0.391	mg/Kg dry	0.78198	ND	123	50-135			
Acenaphthylene	0.764	0.391	mg/Kg dry	0.78198	ND	98	51-134			
Anthracene	0.909	0.391	mg/Kg dry	0.78198	0.0199	114	52-117			
Benzo(a)anthracene	0.720	0.391	mg/Kg dry	0.78198	0.106	79	50-126			
Benzo(b)fluoranthene	0.665	0.391	mg/Kg dry	0.78198	0.0509	79	57-134			
Benzo(k)fluoranthene	0.680	0.391	mg/Kg dry	0.78198	0.0565	80	59-168			
Benzo(g,h,i)perylene	0.430	0.391	mg/Kg dry	0.78198	ND	55	56-147			S
Benzo(a)pyrene	0.567	0.0704	mg/Kg dry	0.78198	0.0528	66	41-133			
Chrysene	0.547	0.391	mg/Kg dry	0.78198	0.0744	60	52-127			
Dibenz(a,h)anthracene	0.287	0.0704	mg/Kg dry	0.78198	ND	37	60-170			S
Fluoranthene	0.927	0.391	mg/Kg dry	0.78198	0.186	95	57-130			
Fluorene	0.722	0.391	mg/Kg dry	0.78198	ND	92	47-154			
Indeno(1,2,3-cd)pyrene	0.506	0.391	mg/Kg dry	0.78198	ND	65	59-132			
Naphthalene	0.886	0.391	mg/Kg dry	0.78198	ND	113	40-135			
Phenanthrene	0.934	0.391	mg/Kg dry	0.78198	0.0823	109	54-126			
Pyrene	1.06	0.391	mg/Kg dry	0.78198	0.130	120	57-132			
Surrogate: 2-Fluorobiphenyl	0.557		mg/Kg dry	0.78198		71	38-122			
Surrogate: Nitrobenzene-d5	0.685		mg/Kg dry	0.78198		88	45-136			
Surrogate: 4-Terphenyl-d14	0.624		mg/Kg dry	0.78198		80	57-122			

Matrix Spike Dup (Z005803-MSD1)	Source: 1610759-05			Prepared & Analyzed: 09/30/2016						
Acenaphthene	0.928	0.392	mg/Kg dry	0.78379	ND	118	50-135	4	20	
Acenaphthylene	0.749	0.392	mg/Kg dry	0.78379	ND	96	51-134	2	20	
Anthracene	0.883	0.392	mg/Kg dry	0.78379	0.0199	110	52-117	3	20	
Benzo(a)anthracene	0.691	0.392	mg/Kg dry	0.78379	0.106	75	50-126	4	20	
Benzo(b)fluoranthene	0.690	0.392	mg/Kg dry	0.78379	0.0509	82	57-134	4	20	
Benzo(k)fluoranthene	0.682	0.392	mg/Kg dry	0.78379	0.0565	80	59-168	0.3	20	
Benzo(g,h,i)perylene	0.407	0.392	mg/Kg dry	0.78379	ND	52	56-147	5	20	S
Benzo(a)pyrene	0.595	0.0705	mg/Kg dry	0.78379	0.0528	69	41-133	5	20	
Chrysene	0.499	0.392	mg/Kg dry	0.78379	0.0744	54	52-127	9	20	
Dibenz(a,h)anthracene	0.313	0.0705	mg/Kg dry	0.78379	ND	40	60-170	9	20	S
Fluoranthene	0.826	0.392	mg/Kg dry	0.78379	0.186	82	57-130	12	20	
Fluorene	0.721	0.392	mg/Kg dry	0.78379	ND	92	47-154	0.2	20	
Indeno(1,2,3-cd)pyrene	0.465	0.392	mg/Kg dry	0.78379	ND	59	59-132	8	20	
Naphthalene	0.856	0.392	mg/Kg dry	0.78379	ND	109	40-135	3	20	
Phenanthrene	0.877	0.392	mg/Kg dry	0.78379	0.0823	101	54-126	6	20	
Pyrene	0.959	0.392	mg/Kg dry	0.78379	0.130	106	57-132	10	20	
Surrogate: 2-Fluorobiphenyl	0.539		mg/Kg dry	0.78379		69	38-122			
Surrogate: Nitrobenzene-d5	0.701		mg/Kg dry	0.78379		89	45-136			
Surrogate: 4-Terphenyl-d14	0.595		mg/Kg dry	0.78379		76	57-122			

LABORATORY RESULTS

Client: Winston Engineering
Project: Villa Park Rd Recon-Central Blvd

Lab Order: 1610759

Metals by ICP - Quality Control

Analyte	Result	Reporting Limit	Units	Spike Level	Source Result	%REC	%REC Limits	RPD	RPD Limit	Notes
---------	--------	-----------------	-------	-------------	---------------	------	-------------	-----	-----------	-------

Batch Z005801 - SW 3050B Metals

Blank (Z005801-BLK1)

Prepared: 09/30/2016 Analyzed: 10/03/2016

Lead U 0.250 mg/Kg wet

LCS (Z005801-BS1)

Prepared: 09/30/2016 Analyzed: 10/03/2016

Lead 25.6 0.250 mg/Kg wet 25.000 102 80-120

Matrix Spike (Z005801-MS1)

Source: 1610764-06

Prepared: 09/30/2016 Analyzed: 10/03/2016

Lead 38.9 0.292 mg/Kg dry 29.178 15.8 79 75-125

Matrix Spike Dup (Z005801-MSD1)

Source: 1610764-06

Prepared: 09/30/2016 Analyzed: 10/03/2016

Lead 38.9 0.292 mg/Kg dry 29.207 15.8 79 75-125 0.06 20

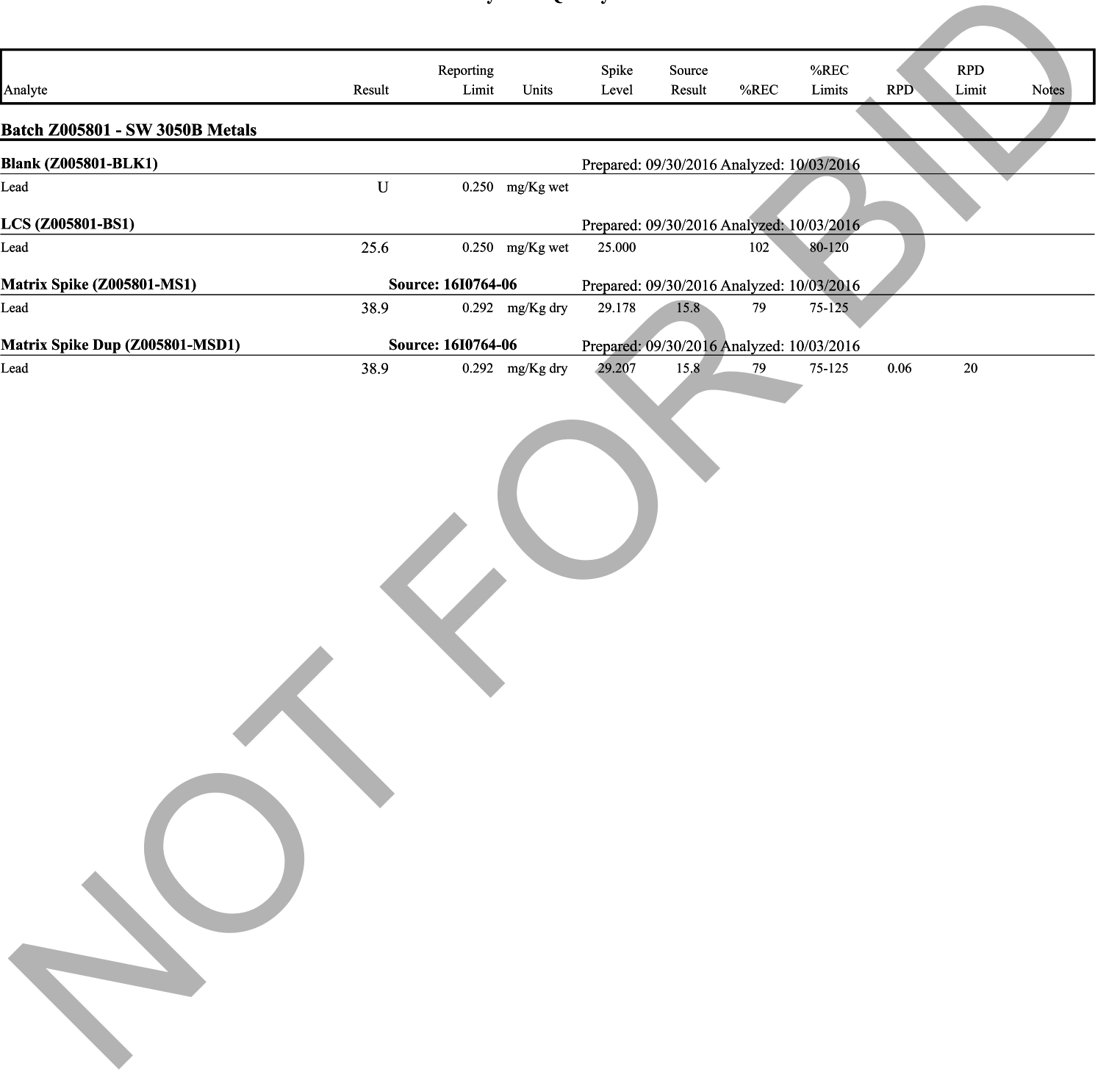

LABORATORY RESULTS

Client: Winston Engineering

Project: Villa Park Rd Recon-Central Blvd

Lab Order: 16I0759

Conventional Chemistry Parameters - Quality Control

Analyte	Result	Reporting Limit	Units	Spike Level	Source Result	%REC	%REC Limits	RPD	RPD Limit	Notes
---------	--------	-----------------	-------	-------------	---------------	------	-------------	-----	-----------	-------

Batch Z005806 - ASTM D2974 Solids

Blank (Z005806-BLK1)

Prepared: 09/30/2016 Analyzed: 10/03/2016

Percent Solids	U	0.100	%							
----------------	---	-------	---	--	--	--	--	--	--	--

Duplicate (Z005806-DUP1)

Source: 16I0759-01

Prepared: 09/30/2016 Analyzed: 10/03/2016

Percent Solids	87.7	0.100	%		88.5			0.9	20	
----------------	------	-------	---	--	------	--	--	-----	----	--

NOT FOR BLD

LABORATORY RESULTS

Client: Winston Engineering

Project: Villa Park Rd Recon-Central Blvd

Lab Order: 16I0759

Notes and Definitions

- S2 Surrogate recovery exceeds the acceptance criteria due to matrix interference, but there is no observable concentration in associated analyte(s).
- S1 Analyte exceeds the laboratory control sample acceptance criteria, but there is no observable concentration in the sample.
- S Spike recovery outside acceptance limits.
- R RPD outside acceptance limits.
- * NELAC certified compound.
- U Analyte not detected (i.e. less than RL or MDL).

NOT FOR BID

Chain of Custody Record

Central IL-1210 Capital Airport Drive - Springfield, IL 62707-8499 - Phone (217) 753-1148 - Facsimile (217) 753-1152
 Chicago Office - 9114 Virginia Rd, Ste 112 - Lake in the Hills, IL 60156 - Phone (847) 551-2604 - Facsimile (847) 458-9690



Prairie Analytical
 Systems, Incorporated

www.prairieanalytical.com

Client	Winston Engineering		Analysis and/or method Requested		Reporting	
Address	2256 Southwind Blvd				TACO	
City, State Zip Code	Bartlett, IL, 60103				Resid	
Phone / Facsimile No.	708-447-1100 ext 289 / andyp@grp7.com				Ind/Comm	
Client Project	Villa Park Road Recon-Central Blvd./adjacent roads				CALM	
Location	Central Blvd./Cortesi Ave./Myrtle Ave.		Field pH		A ___ B ___ C ___	
Sampler(s) / Phone	Andy Paxson / 630-768-7191		Hold		RISC	
Turn-around Time	Standard [x] Rush [] Date Required		Lead		Resid	
P.O. # or Invoice To	Winston Engineering		PNAs		Indust	
Contact Person	Andy Paxson		BETX			

Sample Description	Sampling		Matrix Code ¹	Total # of Containers	Sample		GW - Groundwater	NA - Non-aqueous Liquid	S - Solids	D - Other (Specify)	Received By	Date	Time	Method of Analysis
	Date	Time			Comp	Grab								
VP-1	9/28/2016	8:45am	S	5	X	X						9/29/16	1125	
VP-2	9/28/2016	9:30am	S	5	X	X						9/29/16	125	
VP-3	9/28/2016	9:40am	S	5	X	X			X			9/30/16	1020	UPS
VP-4	9/28/2016	9:55am	S	5	X	X								
VP-5	9/28/2016	10:05am	S	5	X	X								
VP-6	9/28/2016	10:15am	S	5	X	X			X					
VP-7	9/28/2016	10:25am	S	5	X	X								
VP-8	9/28/2016	10:40am	S	5	X	X			X					

M = Matrix Code	A - Aqueous	DW - Drinking Water	GW - Groundwater	NA - Non-aqueous Liquid	S - Solids	D - Other (Specify)
Relinquished By						
M. Coert		9/29/16 11:25am		Matthew Weller		9/29/16 1125
C.P.S.		9/29/16 1255		W. Coert		9/29/16 125
		9/29/16 1700		Jenna Holman		9/30/16 1020
Special Instructions:						
On Wet Ice			On Wet Ice		Temperature (°C)	
1 1 2 3 4			X / N		2.9	



WINSTON ENGINEERING

2256 Southwind Blvd
Bartlett, IL 60103
Phone: 630-503-5028
Fax: 630-524-9020

Sampled By:

- Winston Engineering
- Customer
- Other: _____

Customer Name	Project Name	Project Location	Date Collected	Test Performed By	Date Tested
Rubino Engineering	Villa Park Road Reconstruction/Utility Improvements	Central Blvd. /Myrtle Ave. /Cortesi Ave. Villa Park	9/29/16	AP	9/29/16

pH Meter Mfg: Oakton Instruments
Model #: pH 110 Meter

Method Used: NY Dot GTM-24
Calibration: Time: 2:10pm Date: 9/29

pH Test Results

Soil Sample Number	Soil Sample Name	Sample Matrix	Sample Type	Temp (°C)	pH Test Result
1	VP-1	Solid	Soil	19.7	7.68
2	VP-2	Solid	Soil	19.8	7.63
3	VP-4	Solid	Soil	19.8	7.56
4	VP-5	Solid	Soil	19.8	7.39
5	VP-7	Solid	Soil	20.0	7.22

Analyst Signature:  Title: Environmental Scientist

Should you have any questions regarding your pH test results, or need additional information please call us at (630) 503-5028

Appendix A.5

EDR Report

NOT FOR BID

EDR VISTACheck® Report

Bluff City Materials, Inc.
324 E CENTRAL BLVD
VILLA PARK, IL 60181

A.5b EDR Report



Nationwide Customer Service
Telephone: 1-800-352-0050
Internet: www.edrnet.com

Latitude (North): 41.885915 - 41°53'09.294"
Longitude (West): 87.970463 - 87°58'13.6668"

September 20, 2016

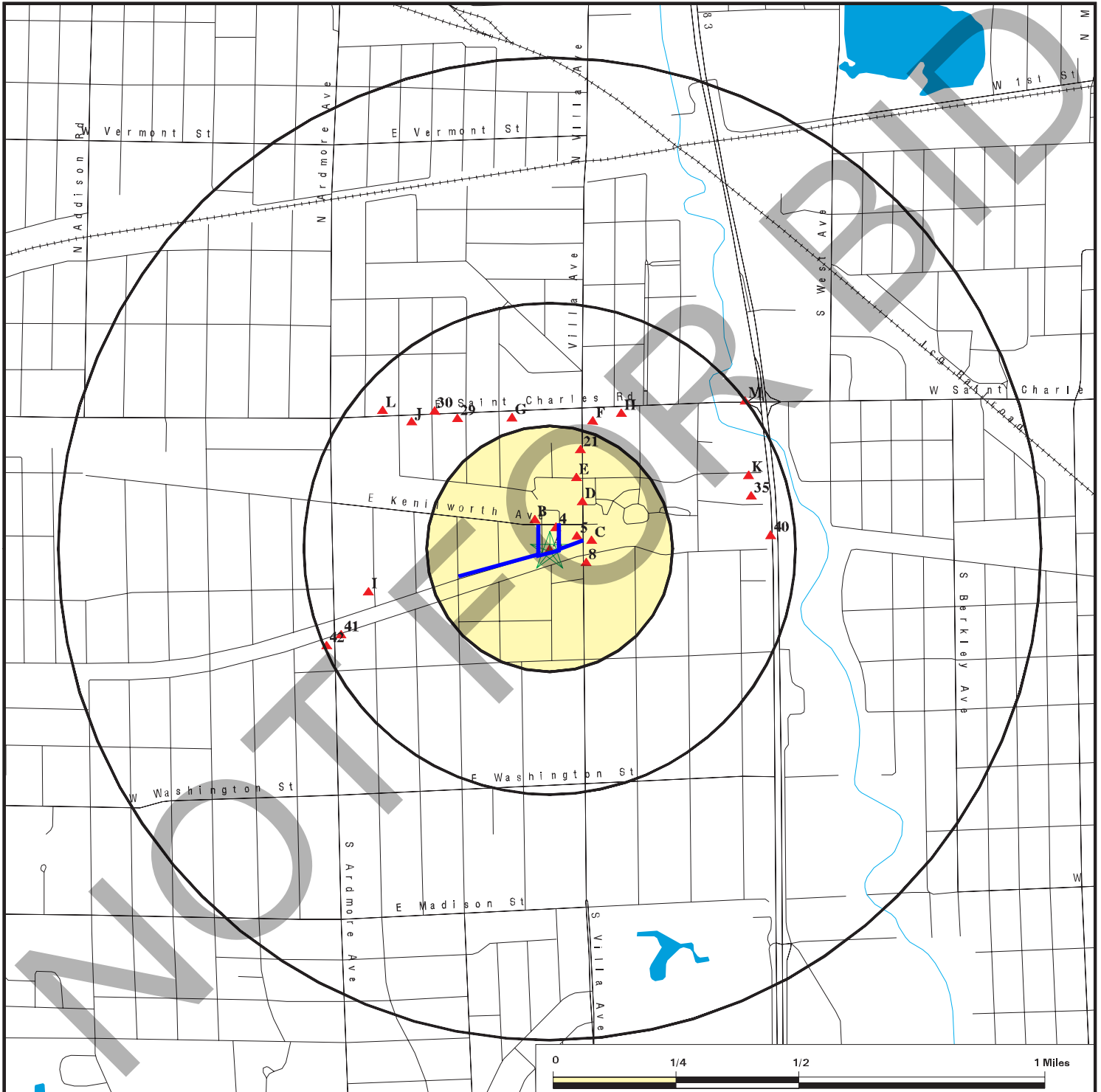

- ★ Target Property
- ▲ Sites
- National Priority List Sites
- Dept. Defense Sites
- Indian Reservations BIA

EDR VISTACheck® Report

<u>SECTION</u>	<u>PAGE</u>
Map Findings Summary	3
Map Findings	7
Orphan Summary	44

Disclaimer - Copyright and Trademark Notice

This Report contains certain information obtained from a variety of public and other sources reasonably available to Environmental Data Resources, Inc. It cannot be concluded from this Report that coverage information for the target and surrounding properties does not exist from other sources. **NO WARRANTY EXPRESSED OR IMPLIED, IS MADE WHATSOEVER IN CONNECTION WITH THIS REPORT. ENVIRONMENTAL DATA RESOURCES, INC. SPECIFICALLY DISCLAIMS THE MAKING OF ANY SUCH WARRANTIES, INCLUDING WITHOUT LIMITATION, MERCHANTABILITY OR FITNESS FOR A PARTICULAR USE OR PURPOSE. ALL RISK IS ASSUMED BY THE USER. IN NO EVENT SHALL ENVIRONMENTAL DATA RESOURCES, INC. BE LIABLE TO ANYONE, WHETHER ARISING OUT OF ERRORS OR OMISSIONS, NEGLIGENCE, ACCIDENT OR ANY OTHER CAUSE, FOR ANY LOSS OF DAMAGE, INCLUDING, WITHOUT LIMITATION, SPECIAL, INCIDENTAL, CONSEQUENTIAL, OR EXEMPLARY DAMAGES. ANY LIABILITY ON THE PART OF ENVIRONMENTAL DATA RESOURCES, INC. IS STRICTLY LIMITED TO A REFUND OF THE AMOUNT PAID FOR THIS REPORT.** Purchaser accepts this Report "AS IS". Any analyses, estimates, ratings, environmental risk levels or risk codes provided in this Report are provided for illustrative purposes only, and are not intended to provide, nor should they be interpreted as providing any facts regarding, or prediction or forecast of, any environmental risk for any property. Only a Phase I Environmental Site Assessment performed by an environmental professional can provide information regarding the environmental risk for any property. Additionally, the information provided in this Report is not to be construed as legal advice.

Copyright 2016 by Environmental Data Resources, Inc. All rights reserved. Reproduction in any media or format, in whole or in part, of any report or map of Environmental Data Resources, Inc., or its affiliates, is prohibited without prior written permission.

EDR and its logos (including Sanborn and Sanborn Map) are trademarks of Environmental Data Resources, Inc. or its affiliates. All other trademarks used herein are the property of their respective owners.

MAP FINDINGS SUMMARY

Database	Search Distance (Miles)	Target Property	< 1/8	1/8 - 1/4	1/4 - 1/2	1/2 - 1	> 1	Total Plotted
STANDARD ENVIRONMENTAL RECORDS								
<i>Federal NPL site list</i>								
NPL	0.500		0	0	0	NR	NR	0
Proposed NPL	0.500		0	0	0	NR	NR	0
NPL LIENS	TP		NR	NR	NR	NR	NR	0
<i>Federal Delisted NPL site list</i>								
Delisted NPL	0.500		0	0	0	NR	NR	0
<i>Federal CERCLIS list</i>								
FEDERAL FACILITY	0.500		0	0	0	NR	NR	0
SEMS	0.500		0	0	0	NR	NR	0
<i>Federal CERCLIS NFRAP site list</i>								
SEMS-ARCHIVE	0.500		0	0	0	NR	NR	0
<i>Federal RCRA CORRACTS facilities list</i>								
CORRACTS	0.500		0	0	0	NR	NR	0
<i>Federal RCRA non-CORRACTS TSD facilities list</i>								
RCRA-TSDF	0.500		0	0	0	NR	NR	0
<i>Federal RCRA generators list</i>								
RCRA-LQG	0.250		0	0	NR	NR	NR	0
RCRA-SQG	0.250		0	1	NR	NR	NR	1
RCRA-CESQG	0.250		0	0	NR	NR	NR	0
<i>Federal institutional controls / engineering controls registries</i>								
LUCIS	0.500		0	0	0	NR	NR	0
US ENG CONTROLS	0.500		0	0	0	NR	NR	0
US INST CONTROL	0.500		0	0	0	NR	NR	0
<i>Federal ERNS list</i>								
ERNS	TP		NR	NR	NR	NR	NR	0
<i>State- and tribal - equivalent CERCLIS</i>								
SSU	0.500		0	0	0	NR	NR	0
<i>State and tribal landfill and/or solid waste disposal site lists</i>								
SWF/LF	0.500		0	0	2	NR	NR	2
CCDD	0.500		0	0	0	NR	NR	0
LF SPECIAL WASTE	0.500		0	0	0	NR	NR	0
IL NIPC	0.500		0	0	0	NR	NR	0
<i>State and tribal leaking storage tank lists</i>								
LUST	0.500		3	1	9	NR	NR	13

MAP FINDINGS SUMMARY

Database	Search Distance (Miles)	Target Property	< 1/8	1/8 - 1/4	1/4 - 1/2	1/2 - 1	> 1	Total Plotted
INDIAN LUST	0.500		0	0	0	NR	NR	0
LUST TRUST	0.500		0	0	0	NR	NR	0
State and tribal registered storage tank lists								
FEMA UST	0.250		0	0	NR	NR	NR	0
UST	0.250		3	1	NR	NR	NR	4
AST	0.250		0	0	NR	NR	NR	0
INDIAN UST	0.250		0	0	NR	NR	NR	0
State and tribal institutional control / engineering control registries								
ENG CONTROLS	0.500		0	0	1	NR	NR	1
INST CONTROL	0.500		1	0	1	NR	NR	2
State and tribal voluntary cleanup sites								
INDIAN VCP	0.500		0	0	0	NR	NR	0
SRP	0.500		1	0	2	NR	NR	3
State and tribal Brownfields sites								
BROWNFIELDS	0.500		0	0	0	NR	NR	0
ADDITIONAL ENVIRONMENTAL RECORDS								
Local Brownfield lists								
US BROWNFIELDS	0.500		0	0	0	NR	NR	0
Local Lists of Landfill / Solid Waste Disposal Sites								
INDIAN ODI	0.500		0	0	0	NR	NR	0
ODI	0.500		0	0	0	NR	NR	0
DEBRIS REGION 9	0.500		0	0	0	NR	NR	0
Local Lists of Hazardous waste / Contaminated Sites								
US HIST CDL	TP		NR	NR	NR	NR	NR	0
CDL	TP		NR	NR	NR	NR	NR	0
US CDL	TP		NR	NR	NR	NR	NR	0
Local Land Records								
LIENS 2	TP		NR	NR	NR	NR	NR	0
Records of Emergency Release Reports								
HMIRS	TP		NR	NR	NR	NR	NR	0
SPILLS	TP		NR	NR	NR	NR	NR	0
Other Ascertainable Records								
RCRA NonGen / NLR	TP		NR	NR	NR	NR	NR	0
FUDS	0.500		0	0	0	NR	NR	0
DOD	0.500		0	0	0	NR	NR	0
SCRD DRYCLEANERS	0.500		0	0	0	NR	NR	0

MAP FINDINGS SUMMARY

Database	Search Distance (Miles)	Target Property	< 1/8	1/8 - 1/4	1/4 - 1/2	1/2 - 1	> 1	Total Plotted
US FIN ASSUR	TP		NR	NR	NR	NR	NR	0
EPA WATCH LIST	TP		NR	NR	NR	NR	NR	0
2020 COR ACTION	0.250		0	0	NR	NR	NR	0
TSCA	TP		NR	NR	NR	NR	NR	0
TRIS	TP		NR	NR	NR	NR	NR	0
SSTS	TP		NR	NR	NR	NR	NR	0
ROD	0.500		0	0	0	NR	NR	0
RMP	TP		NR	NR	NR	NR	NR	0
RAATS	TP		NR	NR	NR	NR	NR	0
PRP	TP		NR	NR	NR	NR	NR	0
PADS	TP		NR	NR	NR	NR	NR	0
ICIS	TP		NR	NR	NR	NR	NR	0
FTTS	TP		NR	NR	NR	NR	NR	0
MLTS	TP		NR	NR	NR	NR	NR	0
COAL ASH DOE	TP		NR	NR	NR	NR	NR	0
COAL ASH EPA	0.500		0	0	0	NR	NR	0
PCB TRANSFORMER	TP		NR	NR	NR	NR	NR	0
RADINFO	TP		NR	NR	NR	NR	NR	0
HIST FTTS	TP		NR	NR	NR	NR	NR	0
DOT OPS	TP		NR	NR	NR	NR	NR	0
CONSENT	0.500		0	0	0	NR	NR	0
INDIAN RESERV	0.500		0	0	0	NR	NR	0
FUSRAP	1.000		0	0	0	0	NR	0
UMTRA	0.500		0	0	0	NR	NR	0
LEAD SMELTERS	TP		NR	NR	NR	NR	NR	0
US AIRS	TP		NR	NR	NR	NR	NR	0
US MINES	0.250		0	0	NR	NR	NR	0
FINDS	TP		NR	NR	NR	NR	NR	0
UXO	1.000		0	0	0	0	NR	0
DOCKET HWC	TP		NR	NR	NR	NR	NR	0
AIRS	TP		NR	NR	NR	NR	NR	0
BOL	TP		NR	NR	NR	NR	NR	0
CHICAGO ENV	TP		NR	NR	NR	NR	NR	0
COAL ASH	0.500		0	0	0	NR	NR	0
DRYCLEANERS	0.250		0	0	NR	NR	NR	0
Financial Assurance	TP		NR	NR	NR	NR	NR	0
HWAR	TP		NR	NR	NR	NR	NR	0
IMPDMNT	0.500		0	0	0	NR	NR	0
NPDES	TP		NR	NR	NR	NR	NR	0
PIMW	0.250		0	0	NR	NR	NR	0
TIER 2	TP		NR	NR	NR	NR	NR	0
UIC	TP		NR	NR	NR	NR	NR	0
ECHO	TP		NR	NR	NR	NR	NR	0
FUELS PROGRAM	0.250		0	0	NR	NR	NR	0

EDR HIGH RISK HISTORICAL RECORDS

EDR Exclusive Records

EDR MGP	0.500		0	0	0	NR	NR	0
EDR Hist Auto	0.250		2	1	NR	NR	NR	3

MAP FINDINGS SUMMARY

Database	Search Distance (Miles)	Target Property	< 1/8	1/8 - 1/4	1/4 - 1/2	1/2 - 1	> 1	Total Plotted
EDR Hist Cleaner	0.250		0	2	NR	NR	NR	2
<u>EDR RECOVERED GOVERNMENT ARCHIVES</u>								
<i>Exclusive Recovered Govt. Archives</i>								
RGA HWS	0.500		0	0	0	NR	NR	0
RGA LF	0.500		0	0	0	NR	NR	0
RGA LUST	0.500		4	1	11	NR	NR	16
- Totals --		0	14	7	26	0	0	47

NOTES:

TP = Target Property

NR = Not Requested at this Search Distance

Sites may be listed in more than one database

MAP FINDINGS

Map ID
 Direction
 Distance
 Distance (ft.)Site

EDR ID Number

Database(s) EPA ID Number

A1
 < 1/8
 1 ft.

324 E CENTRAL BLVD,
 VILLA PARK, IL

SPILLS S117566529
 N/A

Site 1 of 3 in cluster A

SPILLS:

Incident ID: 20140453
 Incident Date: 04/22/2014
 Date Received: Not reported
 Lust Ind: No
 Facility Address: 324 E CENTRAL BLVD,
 Facility City: VILLA PARK
 PRP Name: Unknown
 AC: BOL
 Source Table: dbo_tbl_CONSTRUCTION101

A2
 < 1/8
 1 ft.

324 E CENTRAL BLVD
 VILLA PARK, IL 60181

EDR Hist Auto 1015425823
 N/A

Site 2 of 3 in cluster A

EDR Historical Auto Stations:

Name: M & M AUTO SERVICE
 Year: 1999
 Address: 324 E CENTRAL BLVD

Name: M & M AUTO SERVICE
 Year: 2000
 Address: 324 E CENTRAL BLVD

Name: M & M AUTO SERVICE
 Year: 2001
 Address: 324 E CENTRAL BLVD

Name: M & M AUTO SERVICE
 Year: 2002
 Address: 324 E CENTRAL BLVD

Name: M & M AUTO SERVICE
 Year: 2003
 Address: 324 E CENTRAL BLVD

Name: M & M AUTO SERVICE
 Year: 2004
 Address: 324 E CENTRAL BLVD

Name: M & M AUTO SERVICE
 Year: 2006
 Address: 324 E CENTRAL BLVD

Name: M & M AUTO SERVICE
 Year: 2007
 Address: 324 E CENTRAL BLVD

Name: M & M AUTO SERVICE
 Year: 2008
 Address: 324 E CENTRAL BLVD

MAP FINDINGS

Map ID
 Direction
 Distance
 Distance (ft.)Site

EDR ID Number
 EPA ID Number

Database(s)

(Continued)

1015425823

Name: M & M AUTO SERVICE
 Year: 2009
 Address: 324 E CENTRAL BLVD

Name: M & M AUTO SERVICE
 Year: 2011
 Address: 324 E CENTRAL BLVD

Name: M & M AUTO SERVICE
 Year: 2012
 Address: 324 E CENTRAL BLVD

A3
 < 1/8
 1 ft.

324 E CENTRAL BLVD
 VILLA PARK, IL

SPILLS S116405030
 N/A

Site 3 of 3 in cluster A

IEMA SPILLS:

Incident Number: H-2014-0453
 Incident Report Date: 04/22/2014
 Street Address Of Incident Location: 324 E Central Blvd
 Incident Location City: Villa Park
 Incident Location County: DuPage
 Entered By: Kirgan, Ken (IEMA)
 Date Entered: Not reported
 Data Input Status: Closed
 Leaking Underground Storage Tank (Lust)? : Yes
 Caller: Ann Sarver
 Caller Represents: United States Postal Service
 Hazmat Incident Type: Leak or spill
 Date/Time Occurred: Not reported
 Mile Post: n/a
 Section: n/a
 Township: n/a
 Range: n/a
 Area Involved: Fixed Facility
 Media/Medium Into Which Release Occurred: Ground
 Temp: n/a
 Wind: n/a
 Material Name: suspected gasoline
 Type: Liquid
 Chris Code: unknown
 CAS#: unknown
 UN/NA #: unknown
 302(A) Extremely Hazardous Substance?: Unknown
 Is This A RCRA Hazardous Waste?: Unknown
 Is This A RCRA Regulated Facility?: Unknown
 Container Type: Under ground storage tank
 Container Size: unknown
 Amount Released: unknown
 Rate Of Release/Min: unknown
 Duration Of Release: unknown
 Cause Of Release: unknown
 Estimated Spill Extent: unknown
 Spill Extent Units: Not reported
 Date/Time Incident Occurred: Not reported
 Check If Unknown (Occurrence): v

MAP FINDINGS

Map ID
 Direction
 Distance
 Distance (ft.)Site

EDR ID Number

Database(s) EPA ID Number

(Continued)

S116405030

Date/Time Discovered: 2014-04-22 15:30
 Check If Unknown (Discovered): Not reported
 Where Taken: none
 On Scene Contact: Ann Sarver
 Public Health Risks/Precautions Taken: none
 Number Of People Evacuated: 0
 Assistance Needed From State Agencies: caller would like to be contacted, she can provide information on the report they received on
 Containment/Cleanup Actions And Plans: none
 Responsible Name: unknown to caller
 Facility Manager: unknown to caller
 Facility Manager Phone #: unknown to caller
 Street1: unknown to caller
 Contacted ESDA?: Not reported
 ESDA On Scene?: Not reported
 Specific ESDA Agency Contacted: none
 Contacted Fire Department?: Not reported
 Fire Department On Scene?: Not reported
 Name Of Fire Department Contacted: none
 Contacted Police Department?: Not reported
 Police Department On Scene?: Not reported
 Name Of Police Department Contacted: none
 Sheriff Police Department?: Not reported
 Sheriff Department On Scene?: Not reported
 Name Of Sheriff Department Contacted: none
 Was An Agency Other Than ESDA: Not reported
 Fire Police Or Sheriff Contacted?: Not reported
 Was This Other Agency On Scene?: Not reported
 Name Of Other Agency Contacted: none
 Agency Notified Name: IEMA Region 4
 Date/Time Agency Notified: 2014-04-22 16:33
 Narrative: The caller said the release is coming from next door, which is a closed gas station dating to 1939, located to the south of the caller's property. The address given is believed to be the address of the site the release is coming from.
 Follow Up: Not reported
 Incident Number: H-2014-0453
 Incident Report Date: 04/22/2014
 Street Address Of Incident Location: 324 E Central Blvd
 Incident Location City: Villa Park
 Incident Location County: DuPage
 Entered By: Kirgan, Ken (IEMA)
 Date Entered: Not reported
 Data Input Status: Closed
 Leaking Underground Storage Tank (Lust)? : Yes
 Caller: Ann Sarver
 Caller Represents: United States Postal Service
 Hazmat Incident Type: Leak or spill
 Date/Time Occurred: Not reported
 Mile Post: n/a
 Section: n/a
 Township: n/a
 Range: n/a
 Area Involved: Fixed Facility
 Media/Medium Into Which Release Occurred: Ground
 Temp: n/a
 Wind: n/a

MAP FINDINGS

Map ID
 Direction
 Distance
 Distance (ft.)Site

EDR ID Number
 EPA ID Number

Database(s)

(Continued)

S116405030

Material Name:	suspected gasoline
Type:	Liquid
Chris Code:	unknown
CAS#:	unknown
UN/NA #:	unknown
302(A) Extremely Hazardous Substance?:	Unknown
Is This A RCRA Hazardous Waste?:	Unknown
Is This A RCRA Regulated Facility?:	Unknown
Container Type:	Under ground storage tank
Container Size:	unknown
Amount Released:	unknown
Rate Of Release/Min:	unknown
Duration Of Release:	unknown
Cause Of Release:	unknown
Estimated Spill Extent:	unknown
Spill Extent Units:	Not reported
Date/Time Incident Occurred:	Not reported
Check If Unknown (Occurrence):	v
Date/Time Discovered:	2014-04-22 15:30
Check If Unknown (Discovered):	Not reported
Where Taken:	none
On Scene Contact:	Ann Sarver
Public Health Risks/Precautions Taken:	none
Number Of People Evacuated:	0
Assistance Needed From State Agencies:	caller would like to be contacted, she can provide information on the report they received
Containment/Cleanup Actions And Plans:	none
Responsible Name:	unknown to caller
Facility Manager:	unknown to caller
Facility Manager Phone #:	unknown to caller
Street1:	unknown to caller
Contacted ESDA?:	Not reported
ESDA On Scene?:	Not reported
Specific ESDA Agency Contacted:	none
Contacted Fire Department?:	Not reported
Fire Department On Scene?:	Not reported
Name Of Fire Department Contacted:	none
Contacted Police Department?:	Not reported
Police Department On Scene?:	Not reported
Name Of Police Department Contacted:	none
Sheriff Police Department?:	Not reported
Sheriff Department On Scene?:	Not reported
Name Of Sheriff Department Contacted:	none
Was An Agency Other Than ESDA:	Not reported
Fire Police Or Sheriff Contacted?:	Not reported
Was This Other Agency On Scene?:	Not reported
Name Of Other Agency Contacted:	none
Agency Notified Name:	IEPA, NRTP, OSFM
Date/Time Agency Notified:	2014-04-22 16:33
Narrative:	The caller said the release is coming from next door, which is a closed gas station dating to 1939, located to the south of the caller's property. The address given is believed to be the address of the site the release is coming from.
Follow Up:	Not reported

MAP FINDINGS

Map ID
 Direction
 Distance
 Distance (ft.)Site

EDR ID Number

Database(s) EPA ID Number

4
 NNE
 < 1/8
 0.047 mi.
 248 ft.

ASSOCIATED TECHNICAL SVCS LTD
321 E KENILWORTH AVE
VILLA PARK, IL 60181

INST CONTROL S118193829
SRP N/A
BOL

IL INSTUTIONAL CONTROL:

Illinois EPA Id: 0430805186
 NFR Letter: 02/11/2016
 Date NFR Recorded: Not reported
 Comprehensive / Focused: Focused
 Remediation Applicant Name: Ralph Gross
 RA Company: Associated Technical Services Ltd
 RA Address: 524 West Saint Charles Road
 RA City,St,Zip: Villa Park, IL 60181
 Worker Caution: No
 Acres: 0.69
 Land Use: Industrial/Commercial
 Ground Water Use Restriction: Yes
 Highway Authority Agreement: No
 Ordinance: No
 Industrial - Commercial: Yes
 Slab on Grade: Yes
 BCT: Yes
 Building Slab: No
 Asphalt Used: No
 Concrete Used: No
 Clean Soil 3ft: No
 Clean Soil 10ft: No
 Alternate Barrier: No

SRP:

IL EPA Id: 0430805186
 US EPA Id: Not reported
 Longitude: -87.970407
 Latitude: 41.886284
 Contact Name: Ralph Gross
 Contact Address: 524 West Saint Charles Road
 Contact City,St,Zip: Villa Park, IL 60181
 Date Enrolled: 07/27/2015
 Point Of Contact: Tom Forsmark
 Consultant Company: ETS Environmental & Associates, LLC
 Consultant Address: 204 Dearborn Court
 Consultant City,St,Zip: Geneva, IL 60134
 Proj Mgr Assigned: James Baldwin
 Sec. 4 Letter Date: Not reported
 Active: No
 Remediation Applicant Co: Associated Technical Services Ltd
 Remediation Applicant Name: Ralph Gross
 Remediation Applicant Company: Associated Technical Services Ltd
 Remediation Applicant Address: 524 West Saint Charles Road
 Remediation Applicant City,St,Zip: Villa Park, IL 60181
 Illinois EPA: 0430805186
 Site Name: Associated Technical Services Ltd
 NFR Letter: 2016-02-11
 NFR Letter Date Recorded: Not reported
 Comprehensive/Focused: Focused
 Worker Caution: No
 Acres: 0.69

MAP FINDINGS

Map ID
 Direction
 Distance
 Distance (ft.)Site

EDR ID Number

Database(s) EPA ID Number

ASSOCIATED TECHNICAL SVCS LTD (Continued)

S118193829

Land Use: Industrial/Commercial
 Ground Water Use Restriction: Yes
 Highway Authority Agreement: No
 Ordinance: No
 Industrial - Commercial: Yes
 Slab on Grade: Yes
 BCT: Yes
 Building Slab: No
 Asphalt Used: No
 Concrete Used: No
 Clean Soil 3ft: No
 Clean Soil 10ft: No
 Alternate Barrier: No

Click here for IL SRP:

BOL:

Site Id: 170002111391
 Inv Num: 0430805186
 Interest Name: Associated Technical Svcs Ltd
 Interest Type: BOL
 Media Code: LAND

5
ENE
< 1/8
0.062 mi.
327 ft.

207 S VILLA AVE
VILLA PARK, IL 60181

EDR Hist Auto 1015315311
N/A

EDR Historical Auto Stations:

Name: MIDWEST AUTO ELECTRONICS
 Year: 2007
 Address: 207 S VILLA AVE

Name: MIDWEST AUTO ELECTRONICS
 Year: 2009
 Address: 207 S VILLA AVE

B6
NNW
< 1/8
0.068 mi.
358 ft.

KENILWORTH PARK TOWNHOMES
260 EAST KENILWORTH AVENUE
VILLA PARK, IL 60181

LUST U004051878
UST N/A

Site 1 of 2 in cluster B

LUST:

Incident Num: 20060530
 IL EPA Id: 0430805168
 Product: Other Petroleum
 IEMA Date: 05/04/2006
 Project Manager: Harlow
 Project Manager Phone: Not reported
 Email: Not reported
 PRP Name: Not reported
 PRP Contact: Not reported
 PRP Address: Not reported

MAP FINDINGS

Map ID
 Direction
 Distance
 Distance (ft.)Site

EDR ID Number

Database(s) EPA ID Number

KENILWORTH PARK TOWNHOMES (Continued)

U004051878

PRP City,St,Zip: Not reported
 PRP Phone: Not reported
 Site Classification: Not reported
 Section 57.5(g) Letter: 734
 Date Section 57.5(g) Letter: Not reported
 Non LUST Determination Letter: Not reported
 20 Report Received: 05/19/2006
 45 Report Received: 07/11/2006
NFA/NFR Letter: 09/05/2006
 NFR Date Recorded: 10/05/2006

UST:

Facility ID: 2043211
 Facility Status: EXEMPT
Facility Type: NONE
 Owner Id: U0033356
 Owner Name: New Urban Communities
 Owner Address: 99 South Villa Avenue
 Owner City,St,Zip: Villa Park, IL 60181

Tank Number: 1
Tank Status: Exempt from registration
 Tank Capacity: 3000
 Tank Substance: Heating Oil
 Last Used Date: 12/31/1973
 OSFM First Notify Date: Not reported
 Red Tag Issue Date: Not reported
 Install Date: Not reported
Green Tag Decal: Not reported
Green Tag Issue Date: Not reported
Green Tag Expire Date: Not reported
 Fee Due: Not reported
 Motor Fuel Permit Inspection Date: Not reported
 Motor Fuel Permit Expiration Date: Not reported
 MOTOR FUEL TYPE: Not reported
 Pending Nov: N
 IEMA: 06-0530
 Equipment Type: Not reported
 Equipment: Not reported
 Last Passing Date: Not reported
 Test Expire Date: Not reported

Tank Number: 2
Tank Status: Exempt from registration
 Tank Capacity: 1000
 Tank Substance: Heating Oil
 Last Used Date: 12/31/1973
 OSFM First Notify Date: Not reported
 Red Tag Issue Date: Not reported
 Install Date: Not reported
Green Tag Decal: Not reported
Green Tag Issue Date: Not reported
Green Tag Expire Date: Not reported
 Fee Due: Not reported
 Motor Fuel Permit Inspection Date: Not reported
 Motor Fuel Permit Expiration Date: Not reported

MAP FINDINGS

Map ID
 Direction
 Distance
 Distance (ft.)Site

EDR ID Number
 EPA ID Number

Database(s)

KENILWORTH PARK TOWNHOMES (Continued)

U004051878

MOTOR FUEL TYPE: Not reported
 Pending Nov: N
 IEMA: Not reported
 Equipment Type: Not reported
 Equipment: Not reported
 Last Passing Date: Not reported
 Test Expire Date: Not reported

**B7
 NNW
 < 1/8
 0.068 mi.
 358 ft.**

**NEW URBAN COMMUNITIES
 260 EAST KENILWORTH AVENUE
 VILLA PARK, IL**

RGA LUST

**S115514257
 N/A**

Site 2 of 2 in cluster B

RGA LUST:

2012	NEW URBAN COMMUNITIES	260 EAST KENILWORTH AVENUE
2011	NEW URBAN COMMUNITIES	260 EAST KENILWORTH AVENUE
2010	NEW URBAN COMMUNITIES	260 EAST KENILWORTH AVENUE
2009	NEW URBAN COMMUNITIES	260 EAST KENILWORTH AVENUE
2008	NEW URBAN COMMUNITIES	260 EAST KENILWORTH AVENUE
2007	NEW URBAN COMMUNITIES	260 EAST KENILWORTH AVENUE
2006	NEW URBAN COMMUNITIES	260 EAST KENILWORTH AVENUE

**8
 ESE
 < 1/8
 0.079 mi.
 416 ft.**

**213 - 217 SOUTH VILLA AVE BUILDING
 213 - 217 SOUTH VILLA AVE
 VILLA PARK, IL 60181**

UST

**U003669452
 N/A**

UST:

Facility ID: 2038333
 Facility Status: EXEMPT
Facility Type: COMMERCIAL / RETAIL
 Owner Id: U0028087
 Owner Name: Villa Park Trust & Savings #2077
 Owner Address: 236 W Roosevelt %ReMax Achievers
 Owner City,St,Zip: Villa Park, IL 60181

Tank Number: 1
Tank Status: Exempt from registration
 Tank Capacity: 2000
 Tank Substance: Heating Oil
 Last Used Date: 12/1/1973
 OSFM First Notify Date: Not reported
 Red Tag Issue Date: Not reported
 Install Date: Not reported
Green Tag Decal: Not reported
Green Tag Issue Date: Not reported
Green Tag Expire Date: Not reported
 Fee Due: Not reported
 Motor Fuel Permit Inspection Date: Not reported
 Motor Fuel Permit Expiration Date: Not reported
 MOTOR FUEL TYPE: Not reported
 Pending Nov: N
 IEMA: 99-1024
 Equipment Type: Not reported
 Equipment: Not reported

MAP FINDINGS

Map ID
 Direction
 Distance
 Distance (ft.)Site

EDR ID Number

Database(s) EPA ID Number

213 - 217 SOUTH VILLA AVE BUILDING (Continued)

U003669452

Last Passing Date: Not reported
 Test Expire Date: Not reported

**C9
 ENE
 < 1/8
 0.088 mi.
 463 ft.**

**MAHONEY, MICHELE
 213-217 SOUTH VILLA AVE.
 VILLA PARK, IL**

**RGA LUST S115511979
 N/A**

Site 1 of 2 in cluster C

RGA LUST:

2012	MAHONEY, MICHELE	213-217 SOUTH VILLA AVE.
2011	MAHONEY, MICHELE	213-217 SOUTH VILLA AVE.
2010	MAHONEY, MICHELE	213-217 SOUTH VILLA AVE.
2009	MAHONEY, MICHELE	213-217 SOUTH VILLA AVE.
2008	MAHONEY, MICHELE	213-217 SOUTH VILLA AVE.
2007	MAHONEY, MICHELE	213-217 SOUTH VILLA AVE.
2006	MAHONEY, MICHELE	213-217 SOUTH VILLA AVE.
2005	MAHONEY, MICHELE	213-217 SOUTH VILLA AVE.
2004	MAHONEY, MICHELE	213-217 SOUTH VILLA AVE.
2003	MAHONEY, MICHELE	213-217 SOUTH VILLA AVE.
2002	MAHONEY, MICHELE	213-217 SOUTH VILLA AVE.
2001	MAHONEY, MICHELE	213-217 SOUTH VILLA AVE.
2000	MAHONEY, MICHELE	213-217 SOUTH VILLA AVE.

**C10
 ENE
 < 1/8
 0.088 mi.
 463 ft.**

**MAHONEY, MICHELE
 213-217 SOUTH VILLA AVE.
 VILLA PARK, IL 60181**

**LUST S104529668
 N/A**

Site 2 of 2 in cluster C

LUST:

Incident Num:	991024
IL EPA Id:	0430805126
Product:	Other Petroleum
IEMA Date:	04/26/1999
Project Manager:	Salch
Project Manager Phone:	Not reported
Email:	Not reported
PRP Name:	Michele Mahoney
PRP Contact:	Not reported
PRP Address:	P.O. Box 1283
PRP City,St,Zip:	Wayne, IL 60181
PRP Phone:	6303779903
Site Classification:	Not reported
Section 57.5(g) Letter:	732
Date Section 57.5(g) Letter:	Not reported
Non LUST Determination Letter:	Not reported
20 Report Received:	05/14/1999
45 Report Received:	08/09/1999
NFA/NFR Letter:	09/02/1999
NFR Date Recorded:	10/12/1999

MAP FINDINGS

Map ID
 Direction
 Distance
 Distance (ft.)Site

EDR ID Number

Database(s) EPA ID Number

D11 **LINCOLN PROPERTY CO OVALTINE**
NE **ONE OVALTINE CT**
 < 1/8 **VILLA PARK, IL 60181**
0.110 mi.
581 ft. **Site 1 of 7 in cluster D**

UST **1000292640**
RCRA NonGen / NLR **ILD083076612**

UST:

Facility ID: 2039594
 Facility Status: CLOSED
Facility Type: NONE
 Owner Id: U0029366
 Owner Name: Lincoln Property Company
 Owner Address: 2603 West 22nd Street Suite 22
 Owner City,St,Zip: Oak Brook, IL 60523

Tank Number: 1
Tank Status: Exempt from registration
 Tank Capacity: 1100
 Tank Substance: Mineral Spirits
 Last Used Date: 1/1/1973
 OSFM First Notify Date: Not reported
 Red Tag Issue Date: Not reported
 Install Date: Not reported
Green Tag Decal: Not reported
Green Tag Issue Date: Not reported
Green Tag Expire Date: Not reported
 Fee Due: Not reported
 Motor Fuel Permit Inspection Date: Not reported
 Motor Fuel Permit Expiration Date: Not reported
 MOTOR FUEL TYPE: Not reported
 Pending Nov: N
 IEMA: 00-0540, 00-0541
 Equipment Type: Not reported
 Equipment: Not reported
 Last Passing Date: Not reported
 Test Expire Date: Not reported

Tank Number: 2
Tank Status: Exempt from registration
 Tank Capacity: 1500
 Tank Substance: Gasoline
 Last Used Date: 1/1/1973
 OSFM First Notify Date: Not reported
 Red Tag Issue Date: Not reported
 Install Date: Not reported
Green Tag Decal: Not reported
Green Tag Issue Date: Not reported
Green Tag Expire Date: Not reported
 Fee Due: Not reported
 Motor Fuel Permit Inspection Date: Not reported
 Motor Fuel Permit Expiration Date: Not reported
 MOTOR FUEL TYPE: Not reported
 Pending Nov: N
 IEMA: Not reported
 Equipment Type: Not reported
 Equipment: Not reported
 Last Passing Date: Not reported
 Test Expire Date: Not reported

MAP FINDINGS

Map ID
 Direction
 Distance
 Distance (ft.)Site

EDR ID Number
 EPA ID Number

Database(s)

LINCOLN PROPERTY CO OVALTINE (Continued)

1000292640

RCRA NonGen / NLR:

Date form received by agency: 04/25/2000
 Facility name: LINCOLN PROPERTY CO OVALTINE
 Facility address: ONE OVALTINE CT
 VILLA PARK, IL 60181
 EPA ID: ILD083076612
 Contact: ERIC HOLST
 Contact address: ONE OVALTINE CT
 VILLA PARK, IL 60181
 Contact country: US
 Contact telephone: (630) 530-0759
 Contact email: Not reported
 EPA Region: 05
 Classification: Non-Generator
 Description: Handler: Non-Generators do not presently generate hazardous waste

Owner/Operator Summary:

Owner/operator name: NAME NOT REPORTED
 Owner/operator address: ADDRESS NOT REPORTED
 CITY NOT REPORTED, AK 99998
 Owner/operator country: Not reported
 Owner/operator telephone: (312) 555-1212
 Legal status: Private
 Owner/Operator Type: Operator
 Owner/Op start date: Not reported
 Owner/Op end date: Not reported

Owner/operator name: LINCOLN PROPERTY CO
 Owner/operator address: 2603 W 22ND ST SUITE 22
 OAK BROOK, IL 60521
 Owner/operator country: Not reported
 Owner/operator telephone: (630) 572-6663
 Legal status: Private
 Owner/Operator Type: Owner
 Owner/Op start date: Not reported
 Owner/Op end date: Not reported

Handler Activities Summary:

U.S. importer of hazardous waste: No
 Mixed waste (haz. and radioactive): No
 Recycler of hazardous waste: No
 Transporter of hazardous waste: No
 Treater, storer or disposer of HW: No
 Underground injection activity: No
 On-site burner exemption: No
 Furnace exemption: No
 Used oil fuel burner: No
 Used oil processor: No
 User oil refiner: No
 Used oil fuel marketer to burner: No
 Used oil Specification marketer: No
 Used oil transfer facility: No
 Used oil transporter: No

. Waste code: D001
 . Waste name: IGNITABLE WASTE

MAP FINDINGS

Map ID
 Direction
 Distance
 Distance (ft.)Site

EDR ID Number

Database(s) EPA ID Number

LINCOLN PROPERTY CO OVALTINE (Continued)

1000292640

- . Waste code: D002
- . Waste name: CORROSIVE WASTE

- . Waste code: D003
- . Waste name: REACTIVE WASTE

- . Waste code: F003
- . Waste name: THE FOLLOWING SPENT NONHALOGENATED SOLVENTS: XYLENE, ACETONE, ETHYL ACETATE, ETHYL BENZENE, ETHYL ETHER, METHYL ISOBUTYL KETONE, N-BUTYL ALCOHOL, CYCLOHEXANONE, AND METHANOL; ALL SPENT SOLVENT MIXTURES/BLENDS CONTAINING, BEFORE USE, ONLY THE ABOVE SPENT NONHALOGENATED SOLVENTS; AND ALL SPENT SOLVENT MIXTURES/BLENDS CONTAINING, BEFORE USE, ONE OR MORE OF THE ABOVE NONHALOGENATED SOLVENTS, AND A TOTAL OF TEN PERCENT OR MORE (BY VOLUME) OF ONE OR MORE OF THOSE SOLVENTS LISTED IN F001, F002, F004, AND F005; AND STILL BOTTOMS FROM THE RECOVERY OF THESE SPENT SOLVENTS AND SPENT SOLVENT MIXTURES.

- . Waste code: F005
- . Waste name: THE FOLLOWING SPENT NONHALOGENATED SOLVENTS: TOLUENE, METHYL ETHYL KETONE, CARBON DISULFIDE, ISOBUTANOL, PYRIDINE, BENZENE, 2-ETHOXYETHANOL, AND 2-NITROPROPANE; ALL SPENT SOLVENT MIXTURES/BLENDS CONTAINING, BEFORE USE, A TOTAL OF TEN PERCENT OR MORE (BY VOLUME) OF ONE OR MORE OF THE ABOVE NONHALOGENATED SOLVENTS OR THOSE SOLVENTS LISTED IN F001, F002, OR F004; AND STILL BOTTOMS FROM THE RECOVERY OF THESE SPENT SOLVENTS AND SPENT SOLVENT MIXTURES.

- . Waste code: U242
- . Waste name: U242

- Violation Status: No violations found

D12
 NE
 < 1/8
 0.110 mi.
 581 ft.

**LINCOLN PROPERTY CO.
 1 OVALTINE CT.
 VILLA PARK, IL 60181
 Site 2 of 7 in cluster D**

**LUST S104530570
 BOL N/A**

LUST:
 Incident Num: 20000540
 IL EPA Id: 0430805008
 Product: Other Petroleum
 IEMA Date: 03/28/2000
 Project Manager: Bloome
 Project Manager Phone: Not reported
 Email: Not reported
 PRP Name: Lincoln Property Co.
 PRP Contact: Eric Holst
 PRP Address: 1 Ovaltine Ct.
 PRP City,St,Zip: Villa Park, IL 60181
 PRP Phone: 6305300759
 Site Classification: Not reported
 Section 57.5(g) Letter: 732
 Date Section 57.5(g) Letter: Not reported
 Non LUST Determination Letter: Not reported
 20 Report Received: 04/24/2000
 45 Report Received: 05/22/2000
NFA/NFR Letter: 08/24/2000
 NFR Date Recorded: 09/18/2000

MAP FINDINGS

Map ID
Direction
Distance
Distance (ft.)Site

EDR ID Number
EPA ID Number

Database(s)

LINCOLN PROPERTY CO. (Continued)

S104530570

Incident Num: 20000541
IL EPA Id: 0430805008
Product: Gasoline
IEMA Date: 03/28/2000
Project Manager: Bloome
Project Manager Phone: Not reported
Email: Not reported
PRP Name: Lincoln Properties Co.
PRP Contact: Eric Holst
PRP Address: 1 Ovaltine Ct.
PRP City,St,Zip: Villa Park, IL 60181
PRP Phone: 6305300759
Site Classification: Not reported
Section 57.5(g) Letter: 732
Date Section 57.5(g) Letter: Not reported
Non LUST Determination Letter: Not reported
20 Report Received: 04/24/2000
45 Report Received: 05/22/2000
NFA/NFR Letter: 08/24/2000
NFR Date Recorded: 09/18/2000

BOL:

Site Id: 170000174745
Inv Num: 0430805008
Interest Name: Lincoln Properties Co
Interest Type: BOL
Media Code: LAND

D13
NE
< 1/8
0.110 mi.
581 ft.

LINCOLN PROPERTY CO.
1 OVALTINE CT.
VILLA PARK, IL

RGA LUST

S115511534
N/A

Site 3 of 7 in cluster D

RGA LUST:

2012 LINCOLN PROPERTY CO. 1 OVALTINE CT.
2011 LINCOLN PROPERTY CO. 1 OVALTINE CT.
2010 LINCOLN PROPERTY CO. 1 OVALTINE CT.
2009 LINCOLN PROPERTY CO. 1 OVALTINE CT.
2008 LINCOLN PROPERTY CO. 1 OVALTINE CT.
2007 LINCOLN PROPERTY CO. 1 OVALTINE CT.
2006 LINCOLN PROPERTY CO. 1 OVALTINE CT.
2005 LINCOLN PROPERTY CO. 1 OVALTINE CT.
2004 LINCOLN PROPERTY CO. 1 OVALTINE CT.
2003 LINCOLN PROPERTY CO. 1 OVALTINE CT.
2002 LINCOLN PROPERTY CO. 1 OVALTINE CT.
2001 LINCOLN PROPERTY CO. 1 OVALTINE CT.
2000 LINCOLN PROPERTY CO. 1 OVALTINE CT.

MAP FINDINGS

Map ID
 Direction
 Distance
 Distance (ft.)Site

EDR ID Number

Database(s) EPA ID Number

D14 **LINCOLN PROPERTIES CO.**
NE **1 OVALTINE CT.**
< 1/8 **VILLA PARK, IL**
0.110 mi.
581 ft. **Site 4 of 7 in cluster D**

RGA LUST **S115511533**
N/A

RGA LUST:

2012	LINCOLN PROPERTIES CO.	1 OVALTINE CT.
2011	LINCOLN PROPERTIES CO.	1 OVALTINE CT.
2010	LINCOLN PROPERTIES CO.	1 OVALTINE CT.
2009	LINCOLN PROPERTIES CO.	1 OVALTINE CT.
2008	LINCOLN PROPERTIES CO.	1 OVALTINE CT.
2007	LINCOLN PROPERTIES CO.	1 OVALTINE CT.
2006	LINCOLN PROPERTIES CO.	1 OVALTINE CT.
2005	LINCOLN PROPERTIES CO.	1 OVALTINE CT.
2004	LINCOLN PROPERTIES CO.	1 OVALTINE CT.
2003	LINCOLN PROPERTIES CO.	1 OVALTINE CT.
2002	LINCOLN PROPERTIES CO.	1 OVALTINE CT.
2001	LINCOLN PROPERTIES CO.	1 OVALTINE CT.
2000	LINCOLN PROPERTIES CO.	1 OVALTINE CT.

D15 **VILLA PARK MATERIAL CO**
NNE **110 S VILLA AVE**
1/8-1/4 **VILLA PARK, IL 60181**
0.127 mi.
672 ft. **Site 5 of 7 in cluster D**

UST **U001135452**
N/A

UST:

Facility ID:	2019073
Facility Status:	EXEMPT
Facility Type:	PETROLEUM DISTRIBUTOR
Owner Id:	U0015733
Owner Name:	Villa Park Material Co
Owner Address:	110 S Villa Ave
Owner City,St,Zip:	Villa Park, IL 60181
Tank Number:	1
Tank Status:	Exempt from registration
Tank Capacity:	1000
Tank Substance:	Not reported
Last Used Date:	5/1/1982
OSFM First Notify Date:	4/2/1986
Red Tag Issue Date:	Not reported
Install Date:	1/1/1962
Green Tag Decal:	Not reported
Green Tag Issue Date:	Not reported
Green Tag Expire Date:	Not reported
Fee Due:	Not reported
Motor Fuel Permit Inspection Date:	Not reported
Motor Fuel Permit Expiration Date:	Not reported
MOTOR FUEL TYPE:	Not reported
Pending Nov:	N
IEMA:	Not reported
Equipment Type:	Not reported
Equipment:	Not reported
Last Passing Date:	Not reported
Test Expire Date:	Not reported

MAP FINDINGS

Map ID
 Direction
 Distance
 Distance (ft.)Site

EDR ID Number

Database(s) EPA ID Number

D16 RUGAARD, PRESTON
NNE 110 SOUTH VILLA AVE.
1/8-1/4 VILLA PARK, IL 60181
0.127 mi.
672 ft. Site 6 of 7 in cluster D

LUST S104524477
 N/A

LUST:
 Incident Num: 922860
 IL EPA Id: 0430805094
 Product: Non-Petroleum Product
 IEMA Date: 10/12/1992
 Project Manager: NOT ASSIGNED
 Project Manager Phone: Not reported
 Email: Not reported
 PRP Name: Preston Rugaard
 PRP Contact: Not reported
 PRP Address: 54 East St. Charles Rd.
 PRP City,St,Zip: Villa Park, IL 60181
 PRP Phone: Not reported
 Site Classification: Not reported
 Section 57.5(g) Letter: 731
 Date Section 57.5(g) Letter: Not reported
 Non LUST Determination Letter: Not reported
 20 Report Received: 03/19/1993
 45 Report Received: Not reported
NFA/NFR Letter: Not reported
 NFR Date Recorded: Not reported

D17 RUGAARD, PRESTON
NNE 110 SOUTH VILLA AVE.
1/8-1/4 VILLA PARK, IL
0.127 mi.
672 ft. Site 7 of 7 in cluster D

RGA LUST S115517384
 N/A

RGA LUST:
 2012 RUGAARD, PRESTON 110 SOUTH VILLA AVE.
 2011 RUGAARD, PRESTON 110 SOUTH VILLA AVE.
 2010 RUGAARD, PRESTON 110 SOUTH VILLA AVE.
 2009 RUGAARD, PRESTON 110 SOUTH VILLA AVE.
 2008 RUGAARD, PRESTON 110 SOUTH VILLA AVE.
 2007 RUGAARD, PRESTON 110 SOUTH VILLA AVE.
 2006 RUGAARD, PRESTON 110 SOUTH VILLA AVE.
 2005 RUGAARD, PRESTON 110 SOUTH VILLA AVE.
 2004 RUGAARD, PRESTON 110 SOUTH VILLA AVE.
 2003 RUGAARD, PRESTON 110 SOUTH VILLA AVE.
 2002 RUGAARD, PRESTON 110 SOUTH VILLA AVE.
 2001 RUGAARD, PRESTON 110 SOUTH VILLA AVE.
 2000 RUGAARD, PRESTON 110 SOUTH VILLA AVE.

E18
NNE 100 S VILLA AVE
1/8-1/4 VILLA PARK, IL 60181
0.142 mi.
748 ft. Site 1 of 3 in cluster E

EDR Hist Auto 1015119406
 N/A

EDR Historical Auto Stations:
 Name: VILLA PARK BODY SHOP INCORPORATED
 Year: 1999
 Address: 100 S VILLA AVE

MAP FINDINGS

Map ID
 Direction
 Distance
 Distance (ft.)Site

EDR ID Number

Database(s) EPA ID Number

(Continued)

1015119406

Name: VILLA PARK BODY SHOP INCORPORATED
 Year: 2000
 Address: 100 S VILLA AVE

Name: VILLA PARK AUTO BODY INC
 Year: 2001
 Address: 100 S VILLA AVE

Name: VILLA PARK AUTO BODY INC
 Year: 2002
 Address: 100 S VILLA AVE

Name: VILLA PARK AUTO BODY INC
 Year: 2004
 Address: 100 S VILLA AVE

Name: VILLA PARK AUTO BODY INC
 Year: 2006
 Address: 100 S VILLA AVE

Name: VILLA PARK AUTO BODY INC
 Year: 2007
 Address: 100 S VILLA AVE

Name: VILLA PARK AUTO BODY
 Year: 2008
 Address: 100 S VILLA AVE

Name: VILLA PARK AUTO BODY INC
 Year: 2009
 Address: 100 S VILLA AVE

Name: VILLA PARK BODY SHOP INC
 Year: 2010
 Address: 100 S VILLA AVE

Name: VILLA PARK BODY SHOP INC
 Year: 2011
 Address: 100 S VILLA AVE

Name: VILLA PARK BODY SHOP INC
 Year: 2012
 Address: 100 S VILLA AVE

E19 VILLA PARK BODY SHOP INC
NNE 100 S VILLA AVE
1/8-1/4 VILLA PARK, IL 60181
0.142 mi.
748 ft. Site 2 of 3 in cluster E

RCRA-SQG 1000275673
FINDS ILD065816480
ECHO

RCRA-SQG:
 Date form received by agency: 06/10/1988
 Facility name: VILLA PARK BODY SHOP INC
 Facility address: 100 S VILLA AVE
 VILLA PARK, IL 60181
 EPA ID: ILD065816480
 Contact: GEORGE RENTZ
 Contact address: 100 S VILLA AVE

MAP FINDINGS

Map ID
 Direction
 Distance
 Distance (ft.)Site

EDR ID Number
 EPA ID Number

Database(s)

VILLA PARK BODY SHOP INC (Continued)

1000275673

VILLA PARK, IL 60181
 Contact country: US
 Contact telephone: (312) 530-2324
 Contact email: Not reported
 EPA Region: 05
 Classification: Small Small Quantity Generator
 Description: Handler: generates more than 100 and less than 1000 kg of hazardous waste during any calendar month and accumulates less than 6000 kg of hazardous waste at any time; or generates 100 kg or less of hazardous waste during any calendar month, and accumulates more than 1000 kg of hazardous waste at any time

Owner/Operator Summary:

Owner/operator name: RENTZ GEORGE AND RICHARD
 Owner/operator address: ADDRESS NOT REPORTED
 CITY NOT REPORTED, AK 99998
 Owner/operator country: Not reported
 Owner/operator telephone: (312) 555-1212
 Legal status: Private
 Owner/Operator Type: Owner
 Owner/Op start date: Not reported
 Owner/Op end date: Not reported

Owner/operator name: NAME NOT REPORTED
 Owner/operator address: ADDRESS NOT REPORTED
 CITY NOT REPORTED, AK 99998
 Owner/operator country: Not reported
 Owner/operator telephone: (312) 555-1212
 Legal status: Private
 Owner/Operator Type: Operator
 Owner/Op start date: Not reported
 Owner/Op end date: Not reported

Handler Activities Summary:

U.S. importer of hazardous waste: No
 Mixed waste (haz. and radioactive): No
 Recycler of hazardous waste: No
 Transporter of hazardous waste: No
 Treater, storer or disposer of HW: No
 Underground injection activity: No
 On-site burner exemption: No
 Furnace exemption: No
 Used oil fuel burner: No
 Used oil processor: No
 User oil refiner: No
 Used oil fuel marketer to burner: No
 Used oil Specification marketer: No
 Used oil transfer facility: No
 Used oil transporter: No

. Waste code: D000
 . Waste name: Not Defined

 . Waste code: D001
 . Waste name: IGNITABLE WASTE

MAP FINDINGS

Map ID
Direction
Distance
Distance (ft.)Site

EDR ID Number

Database(s) EPA ID Number

VILLA PARK BODY SHOP INC (Continued)

1000275673

. Waste code: F003
. Waste name: THE FOLLOWING SPENT NONHALOGENATED SOLVENTS: XYLENE, ACETONE, ETHYL ACETATE, ETHYL BENZENE, ETHYL ETHER, METHYL ISOBUTYL KETONE, N-BUTYL ALCOHOL, CYCLOHEXANONE, AND METHANOL; ALL SPENT SOLVENT MIXTURES/BLENDS CONTAINING, BEFORE USE, ONLY THE ABOVE SPENT NONHALOGENATED SOLVENTS; AND ALL SPENT SOLVENT MIXTURES/BLENDS CONTAINING, BEFORE USE, ONE OR MORE OF THE ABOVE NONHALOGENATED SOLVENTS, AND A TOTAL OF TEN PERCENT OR MORE (BY VOLUME) OF ONE OR MORE OF THOSE SOLVENTS LISTED IN F001, F002, F004, AND F005; AND STILL BOTTOMS FROM THE RECOVERY OF THESE SPENT SOLVENTS AND SPENT SOLVENT MIXTURES.

. Waste code: F005
. Waste name: THE FOLLOWING SPENT NONHALOGENATED SOLVENTS: TOLUENE, METHYL ETHYL KETONE, CARBON DISULFIDE, ISOBUTANOL, PYRIDINE, BENZENE, 2-ETHOXYETHANOL, AND 2-NITROPROPANE; ALL SPENT SOLVENT MIXTURES/BLENDS CONTAINING, BEFORE USE, A TOTAL OF TEN PERCENT OR MORE (BY VOLUME) OF ONE OR MORE OF THE ABOVE NONHALOGENATED SOLVENTS OR THOSE SOLVENTS LISTED IN F001, F002, OR F004; AND STILL BOTTOMS FROM THE RECOVERY OF THESE SPENT SOLVENTS AND SPENT SOLVENT MIXTURES.

Violation Status: No violations found

FINDS:

Registry ID: 110005835917

Environmental Interest/Information System

ACES (Illinois - Agency Compliance And Enforcement System) is the Illinois EPA Project to facilitate the permitting operations

RCRAInfo is a national information system that supports the Resource Conservation and Recovery Act (RCRA) program through the tracking of events and activities related to facilities that generate, transport, and treat, store, or dispose of hazardous waste. RCRAInfo allows RCRA program staff to track the notification, permit, compliance, and corrective action activities required under RCRA.

ECHO:

Envid: 1000275673
Registry ID: 110005835917
DFR URL: http://echo.epa.gov/detailed_facility_report?fid=110005835917

E20
NNE 54 S VILLA AVE
1/8-1/4 VILLA PARK, IL 60181
0.171 mi.
901 ft. Site 3 of 3 in cluster E

EDR Hist Cleaner 1015073450
N/A

EDR Historical Cleaners:

Name: ANGIES CLEANERS
Year: 2001
Address: 54 S VILLA AVE

Name: ANGIES CLEANERS
Year: 2002
Address: 54 S VILLA AVE

MAP FINDINGS

Map ID
 Direction
 Distance
 Distance (ft.)Site

EDR ID Number

Database(s) EPA ID Number

(Continued)

1015073450

Name: ANGIES CLEANERS
 Year: 2004
 Address: 54 S VILLA AVE

Name: ANGIES CLEANERS
 Year: 2008
 Address: 54 S VILLA AVE

21
 NNE
 1/8-1/4
 0.213 mi.
 1123 ft.

36 S VILLA AVE
 VILLA PARK, IL 60181

EDR Hist Cleaner 1015049078
 N/A

EDR Historical Cleaners:

Name: JS CLEANERS
 Year: 2001
 Address: 36 S VILLA AVE

Name: JS CLEANERS
 Year: 2002
 Address: 36 S VILLA AVE

Name: JS CLEANERS
 Year: 2009
 Address: 36 S VILLA AVE

F22
 NNE
 1/4-1/2
 0.276 mi.
 1456 ft.

SHELL OIL CO.
 401 EAST ST. CHARLES RD.
 VILLA PARK, IL

RGA LUST S115518312
 N/A

Site 1 of 3 in cluster F

RGA LUST:

2012	SHELL OIL CO.	401 EAST ST. CHARLES RD.
2012	SHELL OIL CO.	401 EAST ST. CHARLES RD.
2011	SHELL OIL CO.	401 EAST ST. CHARLES RD.
2011	SHELL OIL CO.	401 EAST ST. CHARLES RD.
2010	SHELL OIL CO.	401 EAST ST. CHARLES RD.
2010	SHELL OIL CO.	401 EAST ST. CHARLES RD.
2009	SHELL OIL CO.	401 EAST ST. CHARLES RD.
2009	SHELL OIL CO.	401 EAST ST. CHARLES RD.
2008	SHELL OIL CO.	401 EAST ST. CHARLES RD.
2008	SHELL OIL CO.	401 EAST ST. CHARLES RD.
2007	SHELL OIL CO.	401 EAST ST. CHARLES RD.
2007	SHELL OIL CO.	401 EAST ST. CHARLES RD.
2006	SHELL OIL CO.	401 EAST ST. CHARLES RD.
2006	SHELL OIL CO.	401 EAST ST. CHARLES RD.
2005	SHELL OIL CO.	401 EAST ST. CHARLES RD.
2005	SHELL OIL CO.	401 EAST ST. CHARLES RD.
2004	SHELL OIL CO.	401 EAST ST. CHARLES RD.
2004	SHELL OIL CO.	401 EAST ST. CHARLES RD.
2003	SHELL OIL CO.	401 EAST ST. CHARLES RD.
2003	SHELL OIL CO.	401 EAST ST. CHARLES RD.
2002	SHELL OIL CO.	401 EAST ST. CHARLES RD.
2002	SHELL OIL CO.	401 EAST ST. CHARLES RD.

MAP FINDINGS

Map ID
 Direction
 Distance
 Distance (ft.)Site

EDR ID Number
 EPA ID Number

Database(s)

SHELL OIL CO. (Continued)

S115518312

2001 SHELL OIL CO. 401 EAST ST. CHARLES RD.
 2001 SHELL OIL CO. 401 EAST ST. CHARLES RD.
 2000 SHELL OIL CO. 401 EAST ST. CHARLES RD.
 2000 SHELL OIL CO. 401 EAST ST. CHARLES RD.

F23
NNE
1/4-1/2
0.276 mi.
1456 ft.

SHELL OIL CO.
401 EAST ST. CHARLES RD.
VILLA PARK, IL 60181
Site 2 of 3 in cluster F

LUST S104521508
N/A

LUST:

Incident Num: 970076
 IL EPA Id: 0430805060
 Product: Gasoline
 IEMA Date: 01/14/1997
 Project Manager: Urish
 Project Manager Phone: (217) 524-5596
 Email: Matt.Urish@illinois.gov
 PRP Name: Equilon Enterprises LLC
 PRP Contact: Lisa Schoedel
 PRP Address: 603 Diehl Rd., Suite 103
 PRP City,St,Zip: Naperville, IL 60563
 PRP Phone: 6302764206
 Site Classification: HIGH
 Section 57.5(g) Letter: 732
 Date Section 57.5(g) Letter: Not reported
 Non LUST Determination Letter: Not reported
 20 Report Received: 03/25/1997
 45 Report Received: 03/25/1997
NFA/NFR Letter: 04/20/2001
 NFR Date Recorded: 05/11/2001

Incident Num: 970855
 IL EPA Id: 0430805060
 Product: Used Oil
 IEMA Date: 05/15/1997
 Project Manager: Urish
 Project Manager Phone: (217) 524-5596
 Email: Matt.Urish@illinois.gov
 PRP Name: Equilon Enterprises LLC
 PRP Contact: Lisa Schoedel
 PRP Address: 603 Diehl Rd., Suite 103
 PRP City,St,Zip: Naperville, IL 60563
 PRP Phone: 6302764206
 Site Classification: HIGH
 Section 57.5(g) Letter: 732
 Date Section 57.5(g) Letter: Not reported
 Non LUST Determination Letter: Not reported
 20 Report Received: 08/28/1997
 45 Report Received: 08/28/1997
NFA/NFR Letter: 04/20/2001
 NFR Date Recorded: 05/11/2001

Incident Num: 20081051
 IL EPA Id: 0430805060
 Product: Gasoline
 IEMA Date: 07/15/2008
 Project Manager: Urish

MAP FINDINGS

Map ID
 Direction
 Distance
 Distance (ft.)Site

EDR ID Number
 EPA ID Number

Database(s)

SHELL OIL CO. (Continued)

S104521508

Project Manager Phone: (217) 524-5596
 Email: Matt.Urish@illinois.gov
 PRP Name: Not reported
 PRP Contact: Not reported
 PRP Address: Not reported
 PRP City,St,Zip: Not reported
 PRP Phone: Not reported
 Site Classification: Not reported
 Section 57.5(g) Letter: 734
 Date Section 57.5(g) Letter: Not reported
 Non LUST Determination Letter: 2009-01-12
 20 Report Received: 08/11/2008
 45 Report Received: 08/29/2008
NFA/NFR Letter: Not reported
 NFR Date Recorded: Not reported

**F24
 NNE
 1/4-1/2
 0.276 mi.
 1456 ft.**

**SHELL OIL PRODUCTS US
 401 EAST ST. CHARLES ROAD
 VILLA PARK, IL
 Site 3 of 3 in cluster F**

**RGA LUST S115518600
 N/A**

RGA LUST:

2012	SHELL OIL PRODUCTS US	401 EAST ST. CHARLES ROAD
2011	SHELL OIL PRODUCTS US	401 EAST ST. CHARLES ROAD
2010	SHELL OIL PRODUCTS US	401 EAST ST. CHARLES ROAD
2009	SHELL OIL PRODUCTS US	401 EAST ST. CHARLES ROAD
2008	SHELL OIL PRODUCTS US	401 EAST ST. CHARLES ROAD

**G25
 NNW
 1/4-1/2
 0.279 mi.
 1472 ft.**

**TIRE CENTERS, INC.
 299 EAST ST. CHARLES RD.
 VILLA PARK, IL
 Site 1 of 2 in cluster G**

**RGA LUST S115520699
 N/A**

RGA LUST:

2012	TIRE CENTERS, INC.	299 EAST ST. CHARLES RD.
2011	TIRE CENTERS, INC.	299 EAST ST. CHARLES RD.
2010	TIRE CENTERS, INC.	299 EAST ST. CHARLES RD.
2009	TIRE CENTERS, INC.	299 EAST ST. CHARLES RD.
2008	TIRE CENTERS, INC.	299 EAST ST. CHARLES RD.
2007	TIRE CENTERS, INC.	299 EAST ST. CHARLES RD.
2006	TIRE CENTERS, INC.	299 EAST ST. CHARLES RD.
2005	TIRE CENTERS, INC.	299 EAST ST. CHARLES RD.
2004	TIRE CENTERS, INC.	299 EAST ST. CHARLES RD.
2003	TIRE CENTERS, INC.	299 EAST ST. CHARLES RD.
2002	TIRE CENTERS, INC.	299 EAST ST. CHARLES RD.
2001	TIRE CENTERS, INC.	299 EAST ST. CHARLES RD.
2000	TIRE CENTERS, INC.	299 EAST ST. CHARLES RD.

MAP FINDINGS

Map ID
 Direction
 Distance
 Distance (ft.)Site

EDR ID Number

Database(s) EPA ID Number

G26 **TIRE CENTERS, INC.**
NNW **299 EAST ST. CHARLES RD.**
1/4-1/2 **VILLA PARK, IL 60181**
0.279 mi.
1472 ft. **Site 2 of 2 in cluster G**

LUST **S104529213**
N/A

LUST:

Incident Num: 982780
 IL EPA Id: 0430805107
 Product: Used Oil
 IEMA Date: 11/09/1998
 Project Manager: Wallace
 Project Manager Phone: Not reported
 Email: Not reported
 PRP Name: Tire Centers, Inc.
 PRP Contact: Scott Lippoldt
 PRP Address: 299 East St. Charles Rd.
 PRP City,St,Zip: Villa Park, IL 60181
 PRP Phone: 6308323160
 Site Classification: Not reported
 Section 57.5(g) Letter: 732
 Date Section 57.5(g) Letter: Not reported
 Non LUST Determination Letter: Not reported
 20 Report Received: 11/23/1998
 45 Report Received: 01/11/1999
NFA/NFR Letter: 04/05/1999
 NFR Date Recorded: 04/26/1999

H27 **OAKFIELD FORD**
NNE **443 EAST ST. CHARLES RD.**
1/4-1/2 **VILLA PARK, IL**
0.313 mi.
1655 ft. **Site 1 of 2 in cluster H**

RGA LUST **S115514793**
N/A

RGA LUST:

2012	OAKFIELD FORD	443 EAST ST. CHARLES RD.
2011	OAKFIELD FORD	443 EAST ST. CHARLES RD.
2010	OAKFIELD FORD	443 EAST ST. CHARLES RD.
2009	OAKFIELD FORD	443 EAST ST. CHARLES RD.
2008	OAKFIELD FORD	443 EAST ST. CHARLES RD.
2007	OAKFIELD FORD	443 EAST ST. CHARLES RD.
2006	OAKFIELD FORD	443 EAST ST. CHARLES RD.
2005	OAKFIELD FORD	443 EAST ST. CHARLES RD.
2004	OAKFIELD FORD	443 EAST ST. CHARLES RD.
2003	OAKFIELD FORD	443 EAST ST. CHARLES RD.
2002	OAKFIELD FORD	443 EAST ST. CHARLES RD.
2001	OAKFIELD FORD	443 EAST ST. CHARLES RD.
2000	OAKFIELD FORD	443 EAST ST. CHARLES RD.

H28 **OAKFIELD FORD**
NNE **443 E ST CHARLES RD**
1/4-1/2 **VILLA PARK, IL 60181**
0.313 mi.
1655 ft. **Site 2 of 2 in cluster H**

RCRA-SQG **1000612027**
LUST **ILD984822452**
FINDS
ECHO

RCRA-SQG:

Date form received by agency: 04/25/1991
 Facility name: OAKFIELD FORD
 Facility address: 443 E ST CHARLES RD

MAP FINDINGS

Map ID
 Direction
 Distance
 Distance (ft.)Site

EDR ID Number

Database(s) EPA ID Number

OAKFIELD FORD (Continued)

1000612027

EPA ID: VILLA PARK, IL 60181
 ILD984822452
 Contact: MICHAEL MOESE
 Contact address: 443 E ST CHARLES RD
 VILLA PARK, IL 60181
 Contact country: US
 Contact telephone: (708) 534-7600
 Contact email: Not reported
 EPA Region: 05
 Classification: Small Small Quantity Generator
 Description: Handler: generates more than 100 and less than 1000 kg of hazardous waste during any calendar month and accumulates less than 6000 kg of hazardous waste at any time; or generates 100 kg or less of hazardous waste during any calendar month, and accumulates more than 1000 kg of hazardous waste at any time

Owner/Operator Summary:

Owner/operator name: OAKFORD FORD CO
 Owner/operator address: Not reported
 Not reported
 Owner/operator country: Not reported
 Owner/operator telephone: Not reported
 Legal status: Private
 Owner/Operator Type: Owner
 Owner/Op start date: Not reported
 Owner/Op end date: Not reported

Handler Activities Summary:

U.S. importer of hazardous waste: No
 Mixed waste (haz. and radioactive): No
 Recycler of hazardous waste: No
 Transporter of hazardous waste: No
 Treater, storer or disposer of HW: No
 Underground injection activity: No
 On-site burner exemption: No
 Furnace exemption: No
 Used oil fuel burner: No
 Used oil processor: No
 User oil refiner: No
 Used oil fuel marketer to burner: No
 Used oil Specification marketer: No
 Used oil transfer facility: No
 Used oil transporter: No

Waste code: D001
 Waste name: IGNITABLE WASTE

Waste code: D008
 Waste name: LEAD

Violation Status: No violations found

LUST:

Incident Num: 981438
 IL EPA Id: 0430805058
 Product: Gasoline, Used Oil
 IEMA Date: 06/15/1998

MAP FINDINGS

Map ID
 Direction
 Distance
 Distance (ft.)Site

EDR ID Number
 EPA ID Number

Database(s)

OAKFIELD FORD (Continued)

1000612027

Project Manager: Davis
 Project Manager Phone: (217) 785-7492
 Email: Valerie.A.Davis@illinois.gov
 PRP Name: Oakfield Ford
 PRP Contact: Jack Cronan
 PRP Address: 443 East St. Charles Rd.
 PRP City,St,Zip: Villa Park, IL 60181
 PRP Phone: 6308347600
 Site Classification: Not reported
 Section 57.5(g) Letter: 732
 Date Section 57.5(g) Letter: Not reported
 Non LUST Determination Letter: Not reported
 20 Report Received: 07/01/1998
 45 Report Received: 09/04/1998
NFA/NFR Letter: 09/29/1998
 NFR Date Recorded: 10/30/1998

FINDS:

Registry ID: 110005888762

Environmental Interest/Information System

ACES (Illinois - Agency Compliance And Enforcement System) is the Illinois EPA Project to facilitate the permitting operations

RCRAInfo is a national information system that supports the Resource Conservation and Recovery Act (RCRA) program through the tracking of events and activities related to facilities that generate, transport, and treat, store, or dispose of hazardous waste. RCRAInfo allows RCRA program staff to track the notification, permit, compliance, and corrective action activities required under RCRA.

ECHO:

Envid: 1000612027
 Registry ID: 110005888762
 DFR URL: http://echo.epa.gov/detailed_facility_report?fid=110005888762

**29
 NW
 1/4-1/2
 0.326 mi.
 1721 ft.**

**HAFER CLEANERS
 159 EAST ST CHARLES
 VILLA PARK, IL 60181**

**ENG CONTROLS
 INST CONTROL
 SRP
 DRYCLEANERS**

**S111826400
 N/A**

ENGINEERING CONTROLS:

Illinois Epa Id: 0430805027
 NFR Letter: 06/28/2013
 Date NFR Recorded: 07/24/2013
 Comprehensive / Focused: Focused
 Remediation Applicant Name: John Babb
 RA Company: Babb Enterprises, Inc.
 RA Address: 712 Wayside Court
 RA City,St,Zip: Franklin, TN 37069
 Worker Caution: Yes
 Acres: 0.344
 Land Use: Industrial/Commercial
 Ground Water Use Restriction:No

MAP FINDINGS

Map ID
 Direction
 Distance
 Distance (ft.)Site

EDR ID Number

Database(s) EPA ID Number

HAFER CLEANERS (Continued)

S111826400

Highway Authority Agreement: No
 Ordinance: Yes
 Industrial - Commercial: Yes
 Slab on Grade: No
 BCT: No
 Building Slab: Yes
 Asphalt Used: Yes
 Concrete Used: No
 Clean Soil 3ft: No
 Clean Soil 10ft: No
 Alternate Barrier: No

IL INSTUTIONAL CONTROL:

Illinois EPA Id: 0430805027
 NFR Letter: 06/28/2013
 Date NFR Recorded: 07/24/2013
 Comprehensive / Focused: Focused
 Remediation Applicant Name: John Babb
 RA Company: Babb Enterprises, Inc.
 RA Address: 712 Wayside Court
 RA City,St,Zip: Franklin, TN 37069
 Worker Caution: Yes
 Acres: 0.344
 Land Use: Industrial/Commercial
 Ground Water Use Restriction: No
 Highway Authority Agreement: No
 Ordinance: Yes
 Industrial - Commercial: Yes
 Slab on Grade: No
 BCT: No
 Building Slab: Yes
 Asphalt Used: Yes
 Concrete Used: No
 Clean Soil 3ft: No
 Clean Soil 10ft: No
 Alternate Barrier: No

SRP:

IL EPA Id: 0430805027
 US EPA Id: ILD981793508
 Longitude: -87.973941
 Latitude: 41.889549
 Contact Name: John Babb
 Contact Address: 712 Wayside Court
 Contact City,St,Zip: Franklin, TN 37069
 Date Enrolled: 09/20/2012
 Point Of Contact: Marie Mueller
 Consultant Company: Mostardi Platt
 Consultant Address: 888 Industrial Drive
 Consultant City,St,Zip: Elmhurst, IL 60126
 Proj Mgr Assigned: Andrew Catlin
 Sec. 4 Letter Date: Not reported
 Active: No
 Remediation Applicant Co: Babb Enterprises, Inc.
 Remediation Applicant Name: John Babb
 Remediation Applicant Company: Babb Enterprises, Inc.

MAP FINDINGS

Map ID
 Direction
 Distance
 Distance (ft.)Site

EDR ID Number
 EPA ID Number

Database(s)

HAFER CLEANERS (Continued)

S111826400

Remediation Applicant Address: 712 Wayside Court
 Remediation Applicant City,St,Zip: Franklin, TN 37069
 Illinois EPA: 0430805027
 Site Name: Hafer Cleaners
 NFR Letter: 2013-06-28
 NFR Letter Date Recorded: 2013-07-24
 Comprehensive/Focused: Focused
 Worker Caution: Yes
 Acres: 0.344
 Land Use: Industrial/Commercial
 Ground Water Use Restriction: No
 Highway Authority Agreement: No
 Ordinance: Yes
 Industrial - Commercial: Yes
 Slab on Grade: No
 BCT: No
 Building Slab: Yes
 Asphalt Used: Yes
 Concrete Used: No
 Clean Soil 3ft: No
 Clean Soil 10ft: No
 Alternate Barrier: No

Click here for IL SRP:

DRYCLEANERS:

Facility Id: 2923-4441-01
 DC No: DC-01137
 Facility Contact: BRIAN YIM
 License Expires: 12/31/2016

30
 NW
 1/4-1/2
 0.366 mi.
 1934 ft.

ELMHURST
ELMHURST, IL 60553

SWF/LF S108111341
N/A

IL WMRC_LF:
 Region: WMRC
 General: Not reported
 IEPA ID Number: 439999999
 Municipal Waste: Not reported
 Provisional IEPA ID: 043035000B
 Septic: Not reported
 NIPC Map Number: Not reported
 Animal: Not reported
 Owner Name: NOT AVAILABLE
 Pathological: Not reported
 Operator: NOT AVAILABLE
 Industrial: Not reported
 PO Box: Not reported
 Foundry Sand: Not reported
 Incinerator Ash: Not reported
 Slag: Not reported
 Hazardous: Not reported
 Hazardous Liquid: Not reported

MAP FINDINGS

Map ID
 Direction
 Distance
 Distance (ft.)Site

EDR ID Number

Database(s) EPA ID Number

ELMHURST (Continued)

S10811341

Radiation:	Not reported
Demolition:	Not reported
Lat/Long:	415324/875830
Landscaping:	Not reported
Oil Field:	Not reported
Primemer ID:	3
Special:	Not reported
Township:	38N
Other:	Not reported
Range:	11E
Unknown:	X
Section:	Not reported
Quarter Section1:	Not reported
Quarter Section2:	Not reported
Quarter Section3:	Not reported
Quarter Section4:	Not reported
IEPA:	Not reported
ISGS:	Not reported
PollutionControlBoard:	Not reported
IDM&M:	Not reported
DPH:	Not reported
Operational Status:	Not reported
Local Agency:	X
Permit Status:	Not reported
Agency:	NIPC
IEPA Permit Date:	Not reported
Source Other:	Not reported
Close Date:	Not reported
Reaction:	Not reported
RCRA Facility:	Not reported
Date Discover:	Not reported
GW Monitoring:	Not reported
Date Cleaned:	Not reported
FD Site:	Not reported
Offsite Waste:	Not reported
Landfill Size:	Not reported
Random Dump:	Not reported
Size Fill:	Not reported
Open Dump:	Not reported
Leachate Collected:	Not reported
Abandonment:	Not reported
Other:	Not reported
Recompacted Clay:	Not reported
In-situ Clay:	Not reported
Secured Containers:	Not reported
Combination:	Not reported
Landfill:	Not reported
None:	Not reported
Incineration:	Not reported
Other:	Not reported
Survace Impoundment:	Not reported
Land Application:	Not reported



MAP FINDINGS

Map ID
 Direction
 Distance
 Distance (ft.) Site Database(s) EDR ID Number
 EPA ID Number

I31 **ST. ALEXANDER'S CHURCH** **RGA LUST** **S115519607**
WSW **300 SOUTH CORNELL AVENUE** **N/A**
1/4-1/2 **VILLA PARK, IL**
0.379 mi.
2000 ft. **Site 1 of 2 in cluster I**

RGA LUST:

2012	ST. ALEXANDER'S CHURCH	300 SOUTH CORNELL AVENUE
2011	ST. ALEXANDER'S CHURCH	300 SOUTH CORNELL AVENUE
2010	ST. ALEXANDER'S CHURCH	300 SOUTH CORNELL AVENUE
2009	ST. ALEXANDER'S CHURCH	300 SOUTH CORNELL AVENUE
2008	ST. ALEXANDER'S CHURCH	300 SOUTH CORNELL AVENUE
2007	ST. ALEXANDER'S CHURCH	300 SOUTH CORNELL AVENUE

I32 **ST. ALEXANDER'S CHURCH** **LUST** **S108480381**
WSW **300 SOUTH CORNELL AVENUE** **N/A**
1/4-1/2 **VILLA PARK, IL 60181**
0.379 mi.
2000 ft. **Site 2 of 2 in cluster I**

LUST:

Incident Num: 20070157
 IL EPA Id: 0430805171
 Product: Other Petroleum
 IEMA Date: 02/15/2007
 Project Manager: Friedel
 Project Manager Phone: (217) 785-5736
 Email: Melinda.Friedel@illinois.gov
 PRP Name: Not reported
 PRP Contact: Not reported
 PRP Address: Not reported
 PRP City,St,Zip: Not reported
 PRP Phone: Not reported
 Site Classification: Not reported
 Section 57.5(g) Letter: 734
 Date Section 57.5(g) Letter: Not reported
 Non LUST Determination Letter: Not reported
 20 Report Received: 03/12/2007
 45 Report Received: 04/02/2007
NFA/NFR Letter: 06/13/2007
 NFR Date Recorded: 08/23/2007

J33 **HEIDEMEIER, ROSALIE ESTATE OF** **RGA LUST** **S115507785**
NW **109 EAST ST. CHARLES RD.** **N/A**
1/4-1/2 **VILLA PARK, IL**
0.383 mi.
2021 ft. **Site 1 of 2 in cluster J**

RGA LUST:

2012	HEIDEMEIER, ROSALIE ESTATE OF	109 EAST ST. CHARLES RD.
2011	HEIDEMEIER, ROSALIE ESTATE OF	109 EAST ST. CHARLES RD.
2010	HEIDEMEIER, ROSALIE ESTATE OF	109 EAST ST. CHARLES RD.
2009	HEIDEMEIER, ROSALIE ESTATE OF	109 EAST ST. CHARLES RD.
2008	HEIDEMEIER, ROSALIE ESTATE OF	109 EAST ST. CHARLES RD.
2007	HEIDEMEIER, ROSALIE ESTATE OF	109 EAST ST. CHARLES RD.
2006	HEIDEMEIER, ROSALIE ESTATE OF	109 EAST ST. CHARLES RD.
2005	HEIDEMEIER, ROSALIE ESTATE OF	109 EAST ST. CHARLES RD.
2004	HEIDEMEIER, ROSALIE ESTATE OF	109 EAST ST. CHARLES RD.
2003	HEIDEMEIER, ROSALIE ESTATE OF	109 EAST ST. CHARLES RD.

MAP FINDINGS

Map ID
 Direction
 Distance
 Distance (ft.)Site

EDR ID Number
 EPA ID Number

Database(s)

HEIDELMEIER, ROSALIE ESTATE OF (Continued)

S115507785

2002 HEIDELMEIER, ROSALIE ESTATE OF 109 EAST ST. CHARLES RD.
 2001 HEIDELMEIER, ROSALIE ESTATE OF 109 EAST ST. CHARLES RD.
 2000 HEIDELMEIER, ROSALIE ESTATE OF 109 EAST ST. CHARLES RD.

**J34
 NW
 1/4-1/2
 0.383 mi.
 2021 ft.**

**HEIDELMEIER, ROSALIE ESTATE OF
 109 EAST ST. CHARLES RD.
 VILLA PARK, IL 60181**

**LUST S104524492
 N/A**

Site 2 of 2 in cluster J

LUST:

Incident Num: 922809
 IL EPA Id: 0430805085
 Product: Gasoline
 IEMA Date: 10/06/1992
 Project Manager: Irwin
 Project Manager Phone: Not reported
 Email: Not reported
 PRP Name: Estate of Rosalie Heidelemier
 PRP Contact: Chuck Brown
 PRP Address: OS 560 Rt. 83
 PRP City,St,Zip: Oak Brook Terrace, IL 60181
 PRP Phone: Not reported
 Site Classification: Not reported
 Section 57.5(g) Letter: 731
 Date Section 57.5(g) Letter: Not reported
 Non LUST Determination Letter: Not reported
 20 Report Received: 01/15/1993
 45 Report Received: 01/15/1993
NFA/NFR Letter: 04/06/1993
 NFR Date Recorded: Not reported

**35
 ENE
 1/4-1/2
 0.425 mi.
 2244 ft.**

**KROTT, EUGENE
 439 MADISON
 VILLA PARK, IL 60181**

**SWF/LF 1008141517
 FINDS N/A
 BOL
 ECHO**

IL WMRC_LF:

Region: WMRC
 General: X
 IEPA ID Number: 430800001
 Municipal Waste: Not reported
 Provisional IEPA ID: Not reported
 Septic: Not reported
 NIPC Map Number: 304
 Animal: Not reported
 Owner Name: EUGENE KROTT
 Pathological: Not reported
 Operator: EUGENE KROTT
 Industrial: Not reported
 PO Box: Not reported
 Foundry Sand: Not reported
 Incinerator Ash: Not reported
 Slag: Not reported
 Hazardous: Not reported
 Hazardous Liquid: Not reported

MAP FINDINGS

Map ID
 Direction
 Distance
 Distance (ft.)Site

EDR ID Number

Database(s) EPA ID Number

KROTT, EUGENE (Continued)

1008141517

Radiation:	Not reported
Demolition:	Not reported
Lat/Long:	415315/875745
Landscaping:	Not reported
Oil Field:	Not reported
Primemer ID:	3
Special:	Not reported
Township:	39N
Other:	Not reported
Range:	11E
Unknown:	Not reported
Section:	15
Quarter Section1:	NE
Quarter Section2:	Not reported
Quarter Section3:	Not reported
Quarter Section4:	Not reported
IEPA:	X
ISGS:	Not reported
PollutionControlBoard:	Not reported
IDM&M:	Not reported
DPH:	Not reported
Operational Status:	CLOSED FINAL COVER
Local Agency:	Not reported
Permit Status:	UNPERMITTED UNAUTHORIZED
Agency:	NIPC
IEPA Permit Date:	Not reported
Source Other:	Not reported
Close Date:	22376
Reaction:	Not reported
RCRA Facility:	Not reported
Date Discover:	Not reported
GW Monitoring:	NO
Date Cleaned:	Not reported
FD Site:	Not reported
Offsite Waste:	Not reported
Landfill Size:	Not reported
Random Dump:	Not reported
Size Fill:	Not reported
Open Dump:	Not reported
Leachate Collected:	Not reported
Abandonment:	Not reported
Other:	Not reported
Recompacted Clay:	Not reported
In-situ Clay:	Not reported
Secured Containers:	Not reported
Combination:	Not reported
Landfill:	X
None:	Not reported
Incineration:	Not reported
Other:	Not reported
Survace Impoundment:	Not reported
Land Application:	Not reported

FINDS:

Registry ID: 110018382613

MAP FINDINGS

Map ID
 Direction
 Distance
 Distance (ft.)Site

EDR ID Number

Database(s) EPA ID Number

KROTT, EUGENE (Continued)

1008141517

Environmental Interest/Information System
 ACES (Illinois - Agency Compliance And Enforcement System) is the
 Illinois EPA Project to facilitate the permitting operations

BOL:

Site Id: 170000560097
 Inv Num: 0430800001
 Interest Name: Krott, Eugene
 Interest Type: BOL
 Media Code: LAND

ECHO:

Envid: 1008141517
 Registry ID: 110018382613
 DFR URL: http://echo.epa.gov/detailed_facility_report?fid=110018382613

**K36
 ENE
 1/4-1/2
 0.432 mi.
 2283 ft.**

**ILLINOIS BELL TELEPHONE
 631 EAST WILDWOOD ST.
 VILLA PARK, IL 60181**

**LUST S104524700
 N/A**

Site 1 of 2 in cluster K

LUST:

Incident Num: 922082
 IL EPA Id: 0430805078
 Product: Gasoline, Diesel
 IEMA Date: 07/30/1992
 Project Manager: Kuhlman
 Project Manager Phone: (217) 785-5715
 Email: Eric.Kuhlman@illinois.gov
 PRP Name: Illinois Bell Telephone
 PRP Contact: Thomas Scheer
 PRP Address: 900 North Villa
 PRP City,St,Zip: Villa Park, IL 60181
 PRP Phone: Not reported
 Site Classification: Not reported
 Section 57.5(g) Letter: 731
 Date Section 57.5(g) Letter: Not reported
 Non LUST Determination Letter: Not reported
 20 Report Received: 08/10/1992
 45 Report Received: 11/23/1992
NFA/NFR Letter: 02/09/2005
 NFR Date Recorded: 03/28/2005

**K37
 ENE
 1/4-1/2
 0.432 mi.
 2283 ft.**

**ILLINOIS BELL TELEPHONE
 631 EAST WILDWOOD ST.
 VILLA PARK, IL**

**RGA LUST S115508749
 N/A**

Site 2 of 2 in cluster K

RGA LUST:

2012 ILLINOIS BELL TELEPHONE 631 EAST WILDWOOD ST.
 2011 ILLINOIS BELL TELEPHONE 631 EAST WILDWOOD ST.
 2010 ILLINOIS BELL TELEPHONE 631 EAST WILDWOOD ST.

MAP FINDINGS

Map ID
 Direction
 Distance
 Distance (ft.)Site

EDR ID Number

Database(s) EPA ID Number

ILLINOIS BELL TELEPHONE (Continued)

S115508749

2009	ILLINOIS BELL TELEPHONE	631 EAST WILDWOOD ST.
2008	ILLINOIS BELL TELEPHONE	631 EAST WILDWOOD ST.
2007	ILLINOIS BELL TELEPHONE	631 EAST WILDWOOD ST.
2006	ILLINOIS BELL TELEPHONE	631 EAST WILDWOOD ST.
2005	ILLINOIS BELL TELEPHONE	631 EAST WILDWOOD ST.
2004	ILLINOIS BELL TELEPHONE	631 EAST WILDWOOD ST.
2003	ILLINOIS BELL TELEPHONE	631 EAST WILDWOOD ST.
2002	ILLINOIS BELL TELEPHONE	631 EAST WILDWOOD ST.
2001	ILLINOIS BELL TELEPHONE	631 EAST WILDWOOD ST.
2000	ILLINOIS BELL TELEPHONE	631 EAST WILDWOOD ST.

**L38
 NW
 1/4-1/2
 0.442 mi.
 2334 ft.**

**ALLEN, WALTER SR. ESTATE
 40 EAST ST. CHARLES RD.
 VILLA PARK, IL**

RGALUST

**S115497415
 N/A**

Site 1 of 2 in cluster L

RGALUST:

2012	ALLEN, WALTER SR. ESTATE	40 EAST ST. CHARLES RD.
2011	ALLEN, WALTER SR. ESTATE	40 EAST ST. CHARLES RD.
2010	ALLEN, WALTER SR. ESTATE	40 EAST ST. CHARLES RD.
2009	ALLEN, WALTER SR. ESTATE	40 EAST ST. CHARLES RD.
2008	ALLEN, WALTER SR. ESTATE	40 EAST ST. CHARLES RD.
2007	ALLEN, WALTER SR. ESTATE	40 EAST ST. CHARLES RD.
2006	ALLEN, WALTER SR. ESTATE	40 EAST ST. CHARLES RD.
2005	ALLEN, WALTER SR. ESTATE	40 EAST ST. CHARLES RD.
2004	ALLEN, WALTER SR. ESTATE	40 EAST ST. CHARLES RD.
2003	ALLEN, WALTER SR. ESTATE	40 EAST ST. CHARLES RD.
2002	ALLEN, WALTER SR. ESTATE	40 EAST ST. CHARLES RD.
2001	ALLEN, WALTER SR. ESTATE	40 EAST ST. CHARLES RD.
2000	ALLEN, WALTER SR. ESTATE	40 EAST ST. CHARLES RD.

**L39
 NW
 1/4-1/2
 0.442 mi.
 2334 ft.**

**ALLEN SENIOR, WALTER
 40 E ST CHARLES RD
 VILLA PARK, IL 60181**

**LUST 1001232118
 SRP ILR000059592**

**RCRA NonGen / NLR
 FINDS
 ECHO**

Site 2 of 2 in cluster L

LUST:

Incident Num: 990392
 IL EPA Id: 0430805125
 Product: Other Petroleum
 IEMA Date: 02/18/1999
 Project Manager: Davis
 Project Manager Phone: (217) 785-7492
 Email: Valerie.A.Davis@illinois.gov
 PRP Name: Walter Allen Sr., Estate
 PRP Contact: Walter Allen Jr.
 PRP Address: 822 South Villa Ave.
 PRP City,St,Zip: Villa Park, IL 60181
 PRP Phone: 6308348573
 Site Classification: Not reported
 Section 57.5(g) Letter: 732
 Date Section 57.5(g) Letter: 01/20/2000
 Non LUST Determination Letter: Not reported
 20 Report Received: 03/10/1999
 45 Report Received: 04/07/1999
NFA/NFR Letter: Not reported

MAP FINDINGS

Map ID
 Direction
 Distance
 Distance (ft.)Site

EDR ID Number

Database(s) EPA ID Number

ALLEN SENIOR, WALTER (Continued)

1001232118

NFR Date Recorded: Not reported

SRP:

IL EPA Id: 0430805125
 US EPA Id: ILR000059592
 Longitude: -87.977195
 Latitude: 41.890125
 Contact Name: Edward Garvey
 Contact Address: 2800 South Finley Road
 Contact City,St,Zip: Downers Grove, IL 60515
 Date Enrolled: 07/06/1999
 Point Of Contact: James E. Huff, P.E.
 Consultant Company: Huff & Huff, Inc.
 Consultant Address: 512 West Burlington Avenue
 Consultant City,St,Zip: LaGrange, IL 60525
 Proj Mgr Assigned: Clayton Bloome
 Sec. 4 Letter Date: Not reported
 Active: No
 Remediation Applicant Co: West Suburban Bank
 Remediation Applicant Name: Edward Garvey
 Remediation Applicant Company: West Suburban Bank
 Remediation Applicant Address: 2800 South Finley Road
 Remediation Applicant City,St,Zip: Downers Grove, IL 60615
 Illinois EPA: 0430805125
 Site Name: Walter Allen, Sr.
 NFR Letter: 2000-07-13
 NFR Letter Date Recorded: 2000-08-14
 Comprehensive/Focused: Focused
 Worker Caution: No
 Acres: 0.59
 Land Use: Residential or Industrial/Commercial
 Ground Water Use Restriction: No
 Highway Authority Agreement: No
 Ordinance: No
 Industrial - Commercial: No
 Slab on Grade: No
 BCT: No
 Building Slab: No
 Asphalt Used: No
 Concrete Used: No
 Clean Soil 3ft: No
 Clean Soil 10ft: No
 Alternate Barrier: No

[Click here for IL SRP:](#)

RCRA NonGen / NLR:

Date form received by agency: 11/01/2007
 Facility name: ALLEN WALTER SENIOR
 Facility address: 40 E ST CHARLES RD
 VILLA PARK, IL 60181
 EPA ID: ILR000059592
 Contact: ENV COORDINATOR
 Contact address: Not reported
 Not reported

MAP FINDINGS

Map ID
 Direction
 Distance
 Distance (ft.)Site

EDR ID Number

Database(s) EPA ID Number

ALLEN SENIOR, WALTER (Continued)

1001232118

Contact country: US
 Contact telephone: (708) 579-5940
 Contact email: Not reported
 EPA Region: 05
 Classification: Non-Generator
 Description: Handler: Non-Generators do not presently generate hazardous waste

Owner/Operator Summary:

Owner/operator name: ALLEN WALTER L ST
 Owner/operator address: 822 S VILLA AVE
 VILLA PARK, IL 60181
 Owner/operator country: Not reported
 Owner/operator telephone: (630) 834-8573
 Legal status: Private
 Owner/Operator Type: Owner
 Owner/Op start date: Not reported
 Owner/Op end date: Not reported

Handler Activities Summary:

U.S. importer of hazardous waste: No
 Mixed waste (haz. and radioactive): No
 Recycler of hazardous waste: No
 Transporter of hazardous waste: No
 Treater, storer or disposer of HW: No
 Underground injection activity: No
 On-site burner exemption: No
 Furnace exemption: No
 Used oil fuel burner: No
 Used oil processor: No
 User oil refiner: No
 Used oil fuel marketer to burner: No
 Used oil Specification marketer: No
 Used oil transfer facility: No
 Used oil transporter: No

Historical Generators:

Date form received by agency: 12/14/1998
 Site name: ALLEN WALTER SENIOR
 Classification: Large Quantity Generator
 . Waste code: D001
 . Waste name: IGNITABLE WASTE
 Violation Status: No violations found

FINDS:

Registry ID: 110003047541

Environmental Interest/Information System

ACES (Illinois - Agency Compliance And Enforcement System) is the Illinois EPA Project to facilitate the permitting operations

RCRAInfo is a national information system that supports the Resource Conservation and Recovery Act (RCRA) program through the tracking of events and activities related to facilities that generate, transport,

MAP FINDINGS

Map ID
 Direction
 Distance
 Distance (ft.)Site

EDR ID Number
 EPA ID Number

Database(s)

ALLEN SENIOR, WALTER (Continued)

1001232118

and treat, store, or dispose of hazardous waste. RCRAInfo allows RCRA program staff to track the notification, permit, compliance, and corrective action activities required under RCRA.

ECHO:

Envid: 1001232118
 Registry ID: 110003047541
 DFR URL: http://echo.epa.gov/detailed_facility_report?fid=110003047541

40
East
1/4-1/2
0.451 mi.
2381 ft.

SALT CREEK SANITARY DIST.
201 SOUTH RT. 83
VILLA PARK, IL

RGALUST

S115517574
N/A

RGALUST:

2012	SALT CREEK SANITARY DIST.	201 SOUTH RT. 83
2011	SALT CREEK SANITARY DIST.	201 SOUTH RT. 83
2010	SALT CREEK SANITARY DIST.	201 SOUTH RT. 83
2009	SALT CREEK SANITARY DIST.	201 SOUTH RT. 83
2008	SALT CREEK SANITARY DIST.	201 SOUTH RT. 83
2007	SALT CREEK SANITARY DIST.	201 SOUTH RT. 83
2006	SALT CREEK SANITARY DIST.	201 SOUTH RT. 83
2005	SALT CREEK SANITARY DIST.	201 SOUTH RT. 83
2004	SALT CREEK SANITARY DIST.	201 SOUTH RT. 83
2003	SALT CREEK SANITARY DIST.	201 SOUTH RT. 83
2002	SALT CREEK SANITARY DIST.	201 SOUTH RT. 83
2001	SALT CREEK SANITARY DIST.	201 SOUTH RT. 83
2000	SALT CREEK SANITARY DIST.	201 SOUTH RT. 83

41
WSW
1/4-1/2
0.459 mi.
2422 ft.

HARTNETT U-SAVE GAS STATION
5 WEST PARK BLVD.
VILLA PARK, IL 60181

LUST

S104524916
N/A

LUST:

Incident Num: 921364
 IL EPA Id: 0430805079
 Product: Unleaded Gas
 IEMA Date: 05/20/1992
 Project Manager: Hamilton
 Project Manager Phone: Not reported
 Email: Not reported
 PRP Name: Hartnett U-Save Gas
 PRP Contact: Tom Hartnett
 PRP Address: P.O. Box 1362
 PRP City,St,Zip: Elmhurst, IL 60126
 PRP Phone: Not reported
 Site Classification: Not reported
 Section 57.5(g) Letter: 731
 Date Section 57.5(g) Letter: Not reported
 Non LUST Determination Letter: Not reported
 20 Report Received: 06/08/1992
 45 Report Received: 12/11/1992
NFA/NFR Letter: 03/17/1994

MAP FINDINGS

Map ID
 Direction
 Distance
 Distance (ft.)Site

EDR ID Number

Database(s) EPA ID Number

HARTNETT U-SAVE GAS STATION (Continued)

S104524916

NFR Date Recorded: Not reported

42
WSW
1/4-1/2
0.494 mi.
2610 ft.

HARTNETT U-SAVE GAS STATION
5 WEST PARK BLVD.
VILLA PARK, IL

RGA LUST S115507667
N/A

RGA LUST:

2012	HARTNETT U-SAVE GAS STATION	5 WEST PARK BLVD.
2011	HARTNETT U-SAVE GAS STATION	5 WEST PARK BLVD.
2010	HARTNETT U-SAVE GAS STATION	5 WEST PARK BLVD.
2009	HARTNETT U-SAVE GAS STATION	5 WEST PARK BLVD.
2008	HARTNETT U-SAVE GAS STATION	5 WEST PARK BLVD.
2007	HARTNETT U-SAVE GAS STATION	5 WEST PARK BLVD.
2006	HARTNETT U-SAVE GAS STATION	5 WEST PARK BLVD.
2005	HARTNETT U-SAVE GAS STATION	5 WEST PARK BLVD.
2004	HARTNETT U-SAVE GAS STATION	5 WEST PARK BLVD.
2003	HARTNETT U-SAVE GAS STATION	5 WEST PARK BLVD.
2002	HARTNETT U-SAVE GAS STATION	5 WEST PARK BLVD.
2001	HARTNETT U-SAVE GAS STATION	5 WEST PARK BLVD.
2000	HARTNETT U-SAVE GAS STATION	5 WEST PARK BLVD.

M43
NE
1/4-1/2
0.500 mi.
2638 ft.

CHARLES TEXACO/CHARLES VILLA
749 WEST ST. CHARLES ROAD
ELMHURST, IL 60126

LUST S118194059
N/A

Site 1 of 2 in cluster M

LUST:

Incident Num: 982571
 IL EPA Id: 0430355249
 Product: Gasoline
 IEMA Date: 10/14/1998
 Project Manager: Kuhlman
 Project Manager Phone: (217) 785-5715
 Email: Eric.Kuhlman@illinois.gov
 PRP Name: Charles Texaco/Charles Villa
 PRP Contact: Charles Rumshas
 PRP Address: 749 West St. Charles Rd.
 PRP City,St,Zip: Elmhurst, IL 60126
 PRP Phone: 6308332079
 Site Classification: Not reported
 Section 57.5(g) Letter: 734
 Date Section 57.5(g) Letter: Not reported
 Non LUST Determination Letter: Not reported
 20 Report Received: 01/25/1999
 45 Report Received: 12/21/1998
NFA/NFR Letter: Not reported
 NFR Date Recorded: Not reported

MAP FINDINGS

Map ID
 Direction
 Distance
 Distance (ft.)Site

EDR ID Number

Database(s) EPA ID Number

M44 **CHARLES TEXACO/CHARLES VILLA**
NE **749 WEST ST. CHARLES RD.**
1/4-1/2 **ELMHURST, IL**
0.500 mi.
2638 ft. **Site 2 of 2 in cluster M**

RGA LUST **S115501359**
N/A

RGA LUST:

2012	CHARLES TEXACO/CHARLES VILLA	749 WEST ST. CHARLES RD.
2011	CHARLES TEXACO/CHARLES VILLA	749 WEST ST. CHARLES RD.
2010	CHARLES TEXACO/CHARLES VILLA	749 WEST ST. CHARLES RD.
2009	CHARLES TEXACO/CHARLES VILLA	749 WEST ST. CHARLES RD.
2008	CHARLES TEXACO/CHARLES VILLA	749 WEST ST. CHARLES RD.
2007	CHARLES TEXACO/CHARLES VILLA	749 WEST ST. CHARLES RD.
2006	CHARLES TEXACO/CHARLES VILLA	749 WEST ST. CHARLES RD.
2005	CHARLES TEXACO/CHARLES VILLA	749 WEST ST. CHARLES RD.
2004	CHARLES TEXACO/CHARLES VILLA	749 WEST ST. CHARLES RD.
2003	CHARLES TEXACO/CHARLES VILLA	749 WEST ST. CHARLES RD.
2002	CHARLES TEXACO/CHARLES VILLA	749 WEST ST. CHARLES RD.
2001	CHARLES TEXACO/CHARLES VILLA	749 WEST ST. CHARLES RD.
2000	CHARLES TEXACO/CHARLES VILLA	749 WEST ST. CHARLES RD.

NOT FOR PUBLICATION

Count: 3 records

ORPHAN SUMMARY

City	EDR ID	Site Name	Site Address	Zip	Database(s)
ELMHURST	S118559141	CROWN METAL MANUFACTURING CO (PARKING LOT IN VILLA PARK)	765 S IL ROUTE 83	60126	INST CONTROL, SRP
LOMBARD	S108966700	LOMBARD VILLAGE OF	SE CORNER OF PARKSIDE AVENUE & MAIN STREET	60148	LUST
VILLA PARK	S118562359	SPARAGNA, PHIL	17 - 19 EAST PARK BOULEVARD	60181	LUST

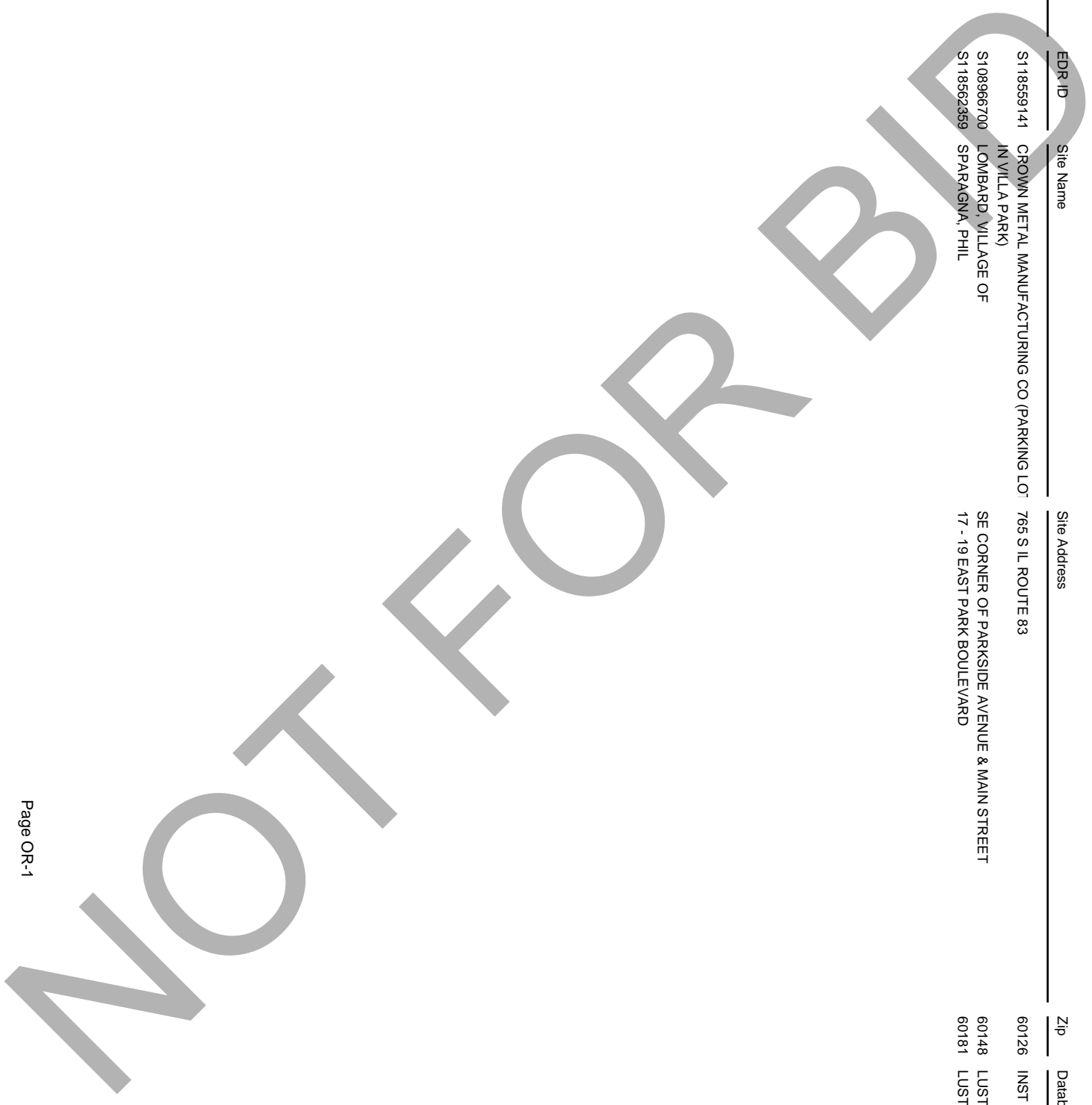



BLUFF CITY MATERIALS, INC

**2252 SOUTHWIND BLVD
BARTLETT, IL 60103**

5 October 2016

Greg Wilcox P.E.
Winston Engineering
2256 Southwind Blvd.
Bartlett, IL 60103
630.503.5028

Re: Letter of Acceptance
Villa Park Road Reconstruction and Utility Improvements CCDD Testing Project

Dear Mr. Wilcox:

Bluff City Materials has reviewed the Winston Engineering LPC-662/LPC-663 and supporting documents for the project named Villa Park Road Reconstruction and Utility Improvements CCDD Testing located in Villa Park, IL. Based on the project information provided in your LPC-662 certification and LPC-663 certification, Bluff City Materials agrees to accept the CCDD certified material at our facilities located in Elgin and Lake in the Hills, IL.

Bluff City Materials is permitted by the IEPA to accept this material and our IEPA Permit number is CCDD2007-028-DE/OP. Our facilities comply with all local zoning codes and all applicable local, state and federal rules and regulations.

If you have any questions, please contact me at 630.497.8700 x 289

Sincerely,

Andy Paxson
Bluff City Materials
Environmental Assessments